

**Documentation of the PROFIBUS Interface of the following
Drives:**

- E1130-DP (-HC, XC)
- E1230-DP-UC
- E1430-DP-QN



PROFIBUS Interface

User Manual

© 2018 NTI AG

This work is protected by copyright.

Under the copyright laws, this publication may not be reproduced or transmitted in any form, electronic or mechanical, including photocopying,

recording, microfilm, storing in an information retrieval system, not even for didactical use, or translating, in whole or in part, without the prior written consent of NTI AG.

LinMot® is a registered trademark of NTI AG.

Note

The information in this documentation reflects the stage of development at the time of press and is therefore without obligation. NTI AG reserves itself the right to make changes at any time and without notice to reflect further technical advance or product improvement.

Document version 3.21 / FM, dc, Ro, August 2018

Table of Content

1 SYSTEM OVERVIEW.....	4
2 INSTALLATION ON DRIVE.....	4
3 CONNECTING TO THE PROFIBUS.....	4
4 PROFIBUS PARAMETERS.....	5
5 PROFIBUS VARIABLES.....	7
6 PROFIBUS MODULES.....	9
7 STATE MACHINE.....	17
8 PROFIBUS DIAGNOSIS.....	17
9 DISPLAY.....	17
10 ERROR CODES.....	17
11 WARN WORD.....	17
12 EXAMPLE FOR SIEMENS SIMATIC S7.....	18
12.1. BUS CONFIGURATION (HW CONFIG).....	18
12.2. HOMING PROCEDURE.....	19
12.3. EXECUTE MOTION COMMAND: VAI Go To Pos (010XH).....	20
12.4. CHANGE A PARAMETER OF THE DRIVE WITH THE PARAMETER CHANNEL MODULE.....	22
13 TROUBLESHOOTING.....	24
14 CONTACT ADDRESSES.....	25

1 System overview

The LinMot PROFIBUS drives E1130-DP, E1230-DP and E1430-DP are PROFIBUS-DP slaves.

Further information on PROFIBUS can be found under: <http://www.profibus.com>

Programming examples provided by LinMot are listed under: http://download.linmot.com/plc_lib/

All baud rates are supported and automatically detected.

2 Installation on Drive

For installing the PROFIBUS-DP firmware on the drive, start the LinMot-Talk software and press the install firmware button . Choose the file "Firmware_Buildxxxxxxx.sct" and press "Open". The wizard will guide you through the installation. The PROFIBUS-DP interface will be automatically selected and loaded.

3 Connecting to the PROFIBUS

Pin Assignment of the DP Connector X9:

The PROFIBUS connector is a standard DSBU 9 female with the following pin assignment:

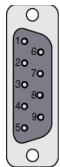

Pin 1	not connected	Pin 6	VP (+5VDC for bus termination)
Pin 2	not connected	Pin 7	not connected
Pin 3	B	Pin 8	A
Pin 4	CNTR-P	Pin 9	not connected
Pin 5	GND		

4 PROFIBUS Parameters

The PROFIBUS drives have an additional parameter tree branch, which can be configured with the distributed LinMot-Talk software. With these parameters, the PROFIBUS behaviour can be configured. The software LinMot-Talk can be downloaded from <http://www.linmot.com> under the section download, software & manuals.

Dis-/Enable

With the Dis-/Enable parameter the LinMot drive can be run without the PROFIBUS going online. So in first step the system can be configured and run without any bus connection.

PROFIBUS Interface \ Dis-/Enable	
Disable	The drive runs without PROFIBUS.
Enable	The drive runs only with a PROFIBUS connection.



IMPORTANT: To activate the PROFIBUS Interface, the Dip-Switch S3.4 “Interface” at the bottom of the drive has to be set to “ON”

S3
ON – OFF
Interface
CAN Term
RS485 Term
RS485/232

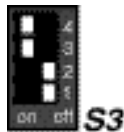

Node Address

This directory contains the parameters defining the node address.

Node Address Selection

The node address selection parameter defines the source of the node address.

PROFIBUS Interface \ Node Address \ Node Address Selection	
By Hex Switches	The node address is determined by the two Hex Switches S1 (ID High) and S2 (ID Low) Attention, the ID defined by S1 and S2 is hexadecimal coded and not decimal!
By Parameter	The node address is determined by the parameter “Node Address Parameter Value”.

By default, the node address is set by the rotary switches S1 and S2.



IMPORTANT: The rotary switches are hexadecimal. According to the PROFIBUS standard the maximal node address is **127** (addresses 126 and 127 are reserved for special purpose and should normally not be used).

Node Address Parameter Value

Defines the node address when “By Parameter” is selected.

Byte Order

Defines the used byte order.

PROFIBUS Interface \ Byte/Word Order \ Byte Order	
Reversed	Byte order is reversed. For S7 PLCs select reversed.
Not reversed	Byte order is not reversed.

Word Order

Defines the used word order.

PROFIBUS Interface \ Byte/Word Order \ Word Order	
Reversed	Word order is reversed. For S7 PLCs select reversed.
Not reversed	Word order is not reversed.

MC CMD Intf Par Order

Defines the used parameter word order.

PROFIBUS Interface \ Byte/Word Order \ MC CMD Intf Par Order	
Reversed	Order is reversed. CMD Header - Par word 1 - Par word 0 - Par word 3 - Par word 2 - etc...
Not reversed	Order is not reversed. CMD Header - Par word 0 - Par word 1 - Par word 2 - Par word 3 - etc...

Diagnose Priority

Defines the behaviour of the diagnostic telegram.

PROFIBUS Interface \ Diagnose Priority	
None	Only minimal diagnostic data is transmitted.
Low	The diagnostic data is sent as status information only.
High	The diagnostic data is sent high priority in the error state.

Monitoring Channels

Defines the source variable by UPID of the four monitoring channels.

PROFIBUS Interface \ Monitoring Channels	
Channel 1 UPID	Source UPID for Monitoring Channel 1
Channel 2 UPID	Source UPID for Monitoring Channel 2
Channel 3 UPID	Source UPID for Monitoring Channel 3
Channel 4 UPID	Source UPID for Monitoring Channel 4

5 PROFIBUS Variables

In the Variables directory of the LinMot-Talk there is a section \PROFIBUS which contains some information about the actual state of the PROFIBUS interface:

- **Node Address:**
This shows the used node address, which can be either configured by the two rotary hex-switches S1/S2 or by parameter settings, as a decimal number.
- **Baud Rate:**
The baud rate is auto detect. This shows the baud rate, which was found on the bus. Zero means no baud rate found.
- **Bus Cycle Time fast:**
This shows the actual cycle time in μs . The fast Cycle time is updated up to 10ms.
- **Bus Cycle Time slow:**
This shows the actual cycle time in ms. This value can be used when the bus cycle time is extremely large ($>10\text{ms}$).
- **DP State:**
This shows the actual state of the LinMot internal DP-State machine:
 - (0) Initialise: The firmware is initialising the PROFIBUS Interface
 - (1) Searching Baud rate: The detection of the baud rate is in progress.
 - (2) Wait for Parameter Telegram: No valid parameter telegram has been received.
 - (3) Wait for Configuration Telegram: No valid configuration telegram has been received.
 - (4) Ready for Data Exchange: The PROFIBUS is ready for Data Exchange, but the master has not done the transition.
 - (5) Data Exchange: The PROFIBUS is running and exchanging cyclic data with the master.

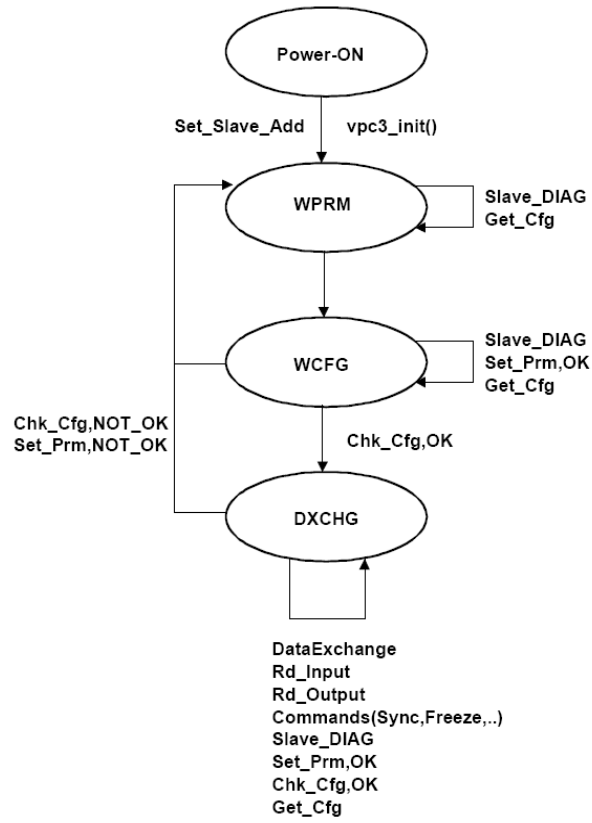

6 PROFIBUS Modules

The LinMot drive is a PROFIBUS-DP slave. To configure it with a PROFIBUS master, the GSD file is used. You can find the GSD file LINM092D.GSD in the LinMot-Talk installation directory (typically C:\Program Files\LinMot\LinTalk-Talk 4 Build xxxxxxxx\Firmware\Profibus\GSD).

There are the following modules defined, to be configured according the demands of the desired application:

Control/Status [1 Word DI/DO]

This module should always be configured. It consists of the Control and Status word, which are described in the document “User Manual Motion Control Software”.

MC Cmd Interface [10 Word DO]

This maps the MC Command interface of the drive. Please refer to the documentation of the MC software.

Attention: Older Siemens S7 CPU firmware cannot directly write more than 4 bytes consistently.



In this case the data has to be sent by SFC15 (please refer to the corresponding Siemens documentation)

Get MC Header Echo [1 Word DI]

This echoes the Cmd Header of the MC Command interface of the drive. Please refer to the documentation of the MC software.

Get Actual Position [2 Word DI]

Returns the actual position of the motor. (32 Bit integer value, resolution 0.1µm)

Get Demand Position [2 Word DI]

Returns the demand position of the motor. (32 Bit integer value, resolution 0.1µm)

Get Current [1 Word DI]

Returns the set current of the motor. (16 Bit integer value, resolution 1mA)

Get StateVar [1 Word DI]

The StateVar consists of MainState and SubState. Please refer to the table “State Var” on chapter 3 of the “User Manual Motion Control Software”.

The StateVar has all relevant flags and information for clean handshaking within one word and can therefore replace the modules “Get MC Header Echo” and “Get Error Code”.

It's strongly recommended to use this module for handshaking.

Get WarnWord [1 Word DI]

Returns the Warn Word. Please refer to chapter 11.

Get ErrorCode [1 Word DI]

Returns the Error Code. Please refer to chapter 10.

Monitoring Channel X [2 Word DI]

Transmits cyclically the value of the variable, which is defined by the Monitoring Channel Parameter (see chapter 4).

Parameter Channel [4 Word DI/DO]

The Parameter Channel module allows access to parameters, variables, curves, error log and command table. Also restart, start and stop of the drive is possible. Of course the Parameter Channel module works independently from the MC Cmd Interface. For this reason changing a parameter and sending a motion command can be done in parallel.

Word	DO	DI
1.	Parameter Channel Control	Parameter Channel Status
2.	Argument (meaning depends on Cmd ID)	Argument (meaning depends on Cmd ID)
3.	Argument (meaning depends on Cmd ID)	Argument (meaning depends on Cmd ID)
4.	Argument (meaning depends on Cmd ID)	Argument (meaning depends on Cmd ID)

Parameter Channel Control

Parameter Command ID to be executed								Reserved				Command Count			
15	14	13	12	11	10	9	8	7	6	5	4	3	2	1	0

The Parameter Channel Control is split in two parts:

- Parameter Command ID to be executed (bits 8-15), see table Command ID
- Command Count (bits 0-3)

Parameter Channel Status

Parameter Status								Reserved				Command Count Response			
15	14	13	12	11	10	9	8	7	6	5	4	3	2	1	0

The Parameter Channel Status is split in two parts:

- Parameter Status (bits 8-15), see table Parameter Status
- Command Count Response (bits 0-3)

Command Count

A new command is only evaluated, if the value of the command count changes. In the easiest way bit 0 could be toggled.

Parameter Command ID

This selects the command.

Possible Commands are:

Command ID	Description
00h	No Operation
Parameter Access	
10h	Read ROM Value of Parameter by UPID
11h	Read RAM Value of Parameter by UPID
12h	Write ROM Value of Parameter by UPID
13h	Write RAM Value of Parameter by UPID
14h	Write RAM and ROM Value of Parameter by UPID
15h	Get minimal Value of Parameter by UPID
16h	Get maximal Value of Parameter by UPID
17h	Get default Value of Parameter by UPID

Parameter (UPID) List	
20h	Start Getting UPID List
21h	Get next UPID List item
22h	Start Getting Modified UPID List
23h	Get next Modified UPID List item
Stop / Start / Default	
30h	Restart drive
31h	Set parameter ROM values to default (OS SW)
32h	Set parameter ROM values to default (MC SW)
33h	Set parameter ROM values to default (Interface SW)
34h	Set parameter ROM values to default (Application SW)
35h	Stop MC and Application Software (for Flash access)
36h	Start MC and Application Software
Curve Service	
40h	Save all Curves from RAM to Flash
41h	Delete all Curves (RAM)
50h	Start Adding Curve (RAM)
51h	Add Curve Info Block (RAM)
52h	Add Curve Data (RAM)
53h	Start Modifying Curve (RAM)
54h	Modify Curve Info Block (RAM)
55h	Modify Curve Data (RAM)
60h	Start Getting Curve (RAM)
61h	Get Curve Info Block (RAM)
62h	Get Curve Data (RAM)
Error Log	
70h	Get Error Log Entry Counter
71h	Get Error Log Entry Error Code
72h	Get Error Log Entry Time low
73h	Get Error Log Entry Time high
74h	Get Error Code Text Stringlet
Command Table	
80h	Command Table: Save to Flash
81h	Command Table: Delete All Entries (RAM)
82h	Command Table: Delete Entry
83h	Command Table: Write Entry
84h	Command Table: Write Entry Data
85h	Command Table: Get Entry
86h	Command Table: Get Entry Data
87h	Get Presence List of Entries 0..31 from RAM
88h	Get Presence List of Entries 32..63 from RAM
89h	Get Presence List of Entries 64..95 from RAM
8Ah	Get Presence List of Entries 96..127 from RAM
8Bh	Get Presence List of Entries 128..159 from RAM
8Ch	Get Presence List of Entries 160..191 from RAM
8Dh	Get Presence List of Entries 192..223 from RAM
8Eh	Get Presence List of Entries 224..255 from RAM

Parameter Status	Description
00h	OK, done
02h	Command Running / Busy
04h	Block not finished (Curve Service)
05h	Busy
C0h	UPID Error
C1h	Parameter Type Error
C2h	Range Error
C3h	Address Usage Error
C5h	Error: Command 21h "Get next UPID List item" was executed without prior execution of "Start Getting UPID Lis"
C6h	End of UPID List reached (no next UPID List item found)
D0h	Odd Address
D1h	Size Error (Curve Service)
D4h	Curve already defined / Curve not present (Curve Service)

Overview Parameter access:

Word	DO	DI
1.	Parameter Channel Control	Parameter Channel Status
2.	Parameter UPID	Parameter UPID
3.	Parameter Value Low	Parameter Value Low
4.	Parameter Value High	Parameter Value High

Overview Curve access:

Word	DO	DI
1.	Parameter Channel Control	Parameter Channel Status
2.	Curve Number	Curve Number
3.	Data Value Low / Info Block size	Data Value Low / Info Block size
4.	Data Value High / Data Block size	Data Value High / Data Block size

Start getting UPID List:

Word	DO	DI
1.	Parameter Channel Control	Parameter Channel Status
2.	Start UPID (search from this UPID)	-
3.	-	-
4.	-	-

Get next UPID List item:

Word	DO	DI
1.	Parameter Channel Control	Parameter Channel Status
2.	-	UPID found
3.	-	Address Usage
4.	-	-

Address Usage:

calculationNot used for Hash															
Life Parameter								ROM Write		ROM Read		RAM Write		RAM Read	
15	14	13	12	11	10	9	8	7	6	5	4	3	2	1	0

Start getting Modified UPID List (Command ID 22h):

Word	DO	DI
1.	Parameter Channel Control	Parameter Channel Status
2.	Start UPID (search from this UPID)	-
3.	-	-
4.	-	-

Get next Modified UPID List item (Command ID 23h):

Word	DO	DI
1.	Parameter Channel Control	Parameter Channel Status
2.	-	UPID found
3.	-	Data Value Low
4.	-	Data Value High

Get Error Log Entry Counter (Command ID 70h):

Word	DO	DI
1.	Parameter Channel Control	Parameter Channel Status
2.	-	-
3.	-	Number of Logged Errors
4.	-	Number of Occurred Errors

Get Error Log Entry Error Code (Command ID 71h):

Word	DO	DI
1.	Parameter Channel Control	Parameter Channel Status
2.	Entry Number (0..20)	Entry Number
3.	-	Logged Error Code
4.	-	-

Get Error Log Entry Time Low (Command ID 72h):

Word	DO	DI
1.	Parameter Channel Control	Parameter Channel Status
2.	Entry Number (0..20)	Entry Number
3.	-	Entry Time Low Word
4.	-	Entry Time Mid Low Word

Get Error Log Entry Time High (Command ID 73h):

Word	DO	DI
1.	Parameter Channel Control	Parameter Channel Status
2.	Entry Number (0..20)	Entry Number
3.	-	Entry Time Mid High Word
4.	-	Entry Time High Word

The Error Log Entry Time consists of 32Bit hours (Time High) and 32Bit ms (Time Low).

Get Error Code Text Stringlet (Command ID 74h):

Word	DO	DI
1.	Parameter Channel Control	Parameter Channel Status
2.	Error Code	Error code
3.	Stringlet Number (0..7)	Stringlet Byte 0 and 1
4.	-	Stringlet Byte 2 and 3

Command Table: Save to Flash (Command ID 75h):

Word	DO	DI
1.	Parameter Channel Control	Parameter Channel Status
2.	-	-
3.	-	-
4.	-	-

For this command, the MC software must be stopped (with command “35h: Stop MC and Application Software”).

The PROFIBUS Interface will stay active while the MC software is stopped.

Command Table: Delete All Entries (RAM) (Command ID 81h)

Word	DO	DI
1.	Parameter Channel Control	Parameter Channel Status
2.	-	-
3.	-	-
4.	-	-

Command Table: Delete Entry (Command ID 82h):

Word	DO	DI
1.	Parameter Channel Control	Parameter Channel Status
2.	Entry Number	Entry Number
3.	-	-
4.	-	-

Command Table: Write Entry (Command ID 83h)

Word	DO	DI
1.	Parameter Channel Control	Parameter Channel Status
2.	Entry Number	Entry Number
3.	Block Size (even number of bytes)	Block Size
4.	-	-

Command Table: Write Entry Data (Command ID 84h)

Word	DO	DI
1.	Parameter Channel Control	Parameter Channel Status
2.	Entry Number	Entry Number
3.	Data	Data
4.	Data	Data

Command Table: Get Entry (Command ID 85h)

Word	DO	DI
1.	Parameter Channel Control	Parameter Channel Status
2.	Entry Number	Entry Number
3.	-	Block Size
4.	-	-

Command Table: Get Entry Data (Command ID 86h)

Word	DO	DI
1.	Parameter Channel Control	Parameter Channel Status
2.	Entry Number	Entry Number
3.	-	Data
4.	-	Data

Command Table: Get Entry List (0..7) (Command IDs 87h .. 8Eh)

Word	DO	DI
1.	Parameter Channel Control	Parameter Channel Status
2.	-	Offset in bytes
3.	-	Bit field (Bit set= undefined / Bit cleared = used)
4.	-	Bit field (Bit set= undefined / Bit cleared = used)



Further documentation on how to configure a drive by fieldbus and handle curves can be found on the additional manual "Parameterization of LinMot E1100 drives over Fieldbus Interfaces".



With STEP7 from Siemens the module "Universal Module" must never be configured.

7 State Machine

Please refer to “User Manual Motion Control Software”.

8 PROFIBUS Diagnosis

The LinMot drive supports 12 bytes of diagnostic data. The diagnosis telegram is according the following table:

Byte	Description
0..5	Data according PROFIBUS-DP standard
6..7	Extended Diagnosis Header and stuffing
8..9	Warn Word (see chapter 11 for description)
10..11	Error Code (see chapter 10 for description)

9 Display

The drive has two real-time LEDs:

- OK (green LED)
- RT BUS ERROR (red LED)

Following you find different blink patterns and their definition:

Green LED	Red LED	Description
Off	Blink: 20Hz	Fatal error
Off	Blink: 2.5Hz	DP State 0: Initialise
Blink alternate: 2.5Hz		DP State 1: Searching Baud rate
Blink: 5Hz	Off	DP State 2: Wait for Parameter Telegram
Blink: 5Hz	Off	DP State 3: Wait for Configuration Telegram
Blink: 5Hz	Off	DP State 4: Ready for Data Exchange
On	Off	DP State 5: Data Exchange

10 Error Codes

Please refer to “User Manual Motion Control Software” for the Error Codes of the MC Software. The PROFIBUS Interface has the following additional Error Codes:

Error Code Hexadecimal	Error Description
C1h	Fatal Error: Drive not supported
C2h	Config Error: Invalid MACID
C3h	DP Err: Connection lost

11 Warn Word

Please refer to “User Manual Motion Control Software”.

12 Example for Siemens Simatic S7

The following example shows the homing procedure, the execution of a motion command and the change of a parameter together with S7 and Simatic from Siemens:

12.1. Bus configuration (HW Config)

Slot	DP ID	...	Order Number / Designation	I Address	Q Address
1	193		Control/Status [1 Word DI/DO]	10...11	10...11
2	129		MC Cmd Interface [10 Word DO]		20...39
3	65		Get StateVar [1 Word DI]	20...21	
4	65		Get Actual Position [2 Word DI]	22...25	
5	65		Get Current [1 Word DI]	26...27	

12.2. Homing procedure

1. Release lock state: Control Word = 0000h (Only needed if StateVar MainState is 00h):

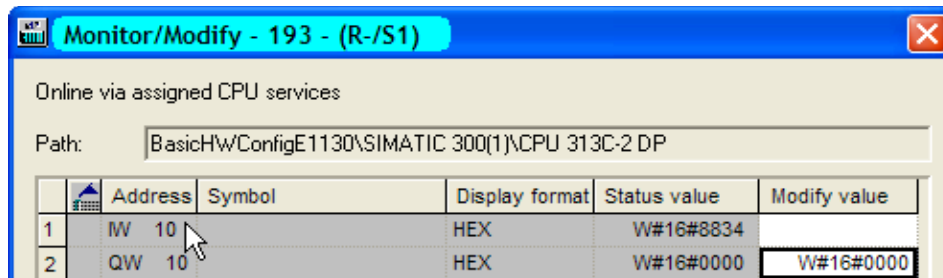

StateVar MainState becomes 02h: Ready to Switch On

	Address	Symbol	Display format	Status value	Modify value
1	IW 20		HEX	W#16#0200	

2. Homing: Control Word = 083Fh

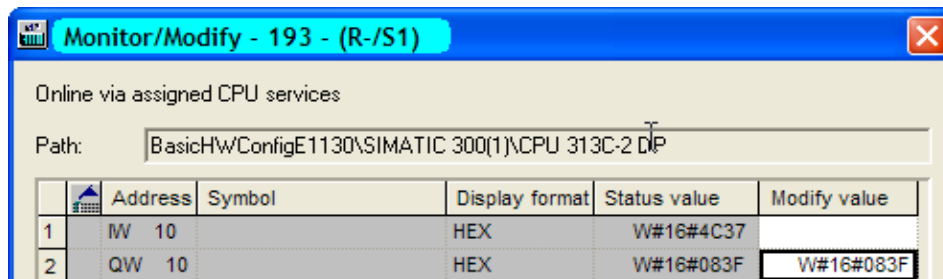

StateVar MainState becomes 09h: Homing, Homing is finished if SubState becomes 0Fh

	Address	Symbol	Display format	Status value	Modify value
1	IW 20		HEX	W#16#090F	

3. Enter Operational State: Control Word = 003Fh

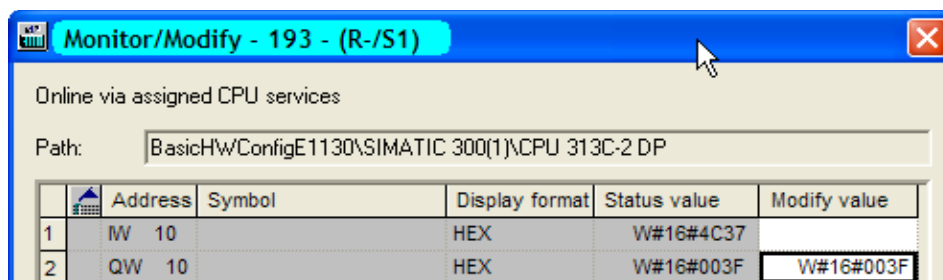

StateVar MainState becomes 08h: Operation Enabled, Drive is ready for motion commands

	Address	Symbol	Display format	Status value	Modify value
1	IW 20		HEX	W#16#08C0	

12.3. Execute Motion Command: VAI Go To Pos (010xh)

Name	Description	Scaled Value	Int. Value (HEX)
Header 0101h	VAI Go To Pos (010xh)	257	
1. Par	Target Position:	50mm	0007A120h
2. Par	Maximal Velocity:	1m/s	000F4240h
3. Par	Acceleration:	10m/s ²	000F4240h
4. Par	Deceleration:	10m/s ²	000F4240h

In the case of \Parameters\PROFIBUS Interface\Byte/Word Order\MC CMD Intf Par Order\not reversed (default setting):

Online via assigned CPU services

Path: BasicHwConfigE1130\SIMATIC 300(1)\CPU 313C-2 DP

	Address	Symbol	Display format	Status value	Modify value
1	QW 20		HEX	W#16#0101	W#16#0101
2	QW 22		HEX	W#16#A120	W#16#A120
3	QW 24		HEX	W#16#0007	W#16#0007
4	QW 26		HEX	W#16#4240	W#16#4240
5	QW 28		HEX	W#16#000F	W#16#000F
6	QW 30		HEX	W#16#4240	W#16#4240
7	QW 32		HEX	W#16#000F	W#16#000F
8	QW 34		HEX	W#16#4240	W#16#4240
9	QW 36		HEX	W#16#000F	W#16#000F
10	QW 38		HEX	W#16#0000	<input type="text"/>

In the case of \Parameters\PROFIBUS Interface\Byte/Word Order\MC CMD Intf Par Order\ reversed:

Online via assigned CPU services

Path: BasicHwConfigE1130\SIMATIC 300(1)\CPU 313C-2 DP

	Address	Symbol	Display format	Status value	Modify value
1	QW 20		HEX	W#16#0101	W#16#0101
2	QW 22		HEX	W#16#0007	W#16#0007
3	QW 24		HEX	W#16#A120	W#16#A120
4	QW 26		HEX	W#16#000F	W#16#000F
5	QW 28		HEX	W#16#4240	W#16#4240
6	QW 30		HEX	W#16#000F	W#16#000F
7	QW 32		HEX	W#16#4240	W#16#4240
8	QW 34		HEX	W#16#000F	W#16#000F
9	QW 36		HEX	W#16#4240	W#16#4240
10	QW 38		HEX	W#16#0000	<input type="text"/>

To send the next command the count nibble has to be changed. The header for the next VAI Go To Pos command is therefore 0100h.

As it appears with LinMot-Talk after “Read Command” in the Control Panel:

Motion Command Interface

Enable Manual Override:
 -10 mm -1 mm +1 mm +10 mm

Command Category: Most Commonly Used ▼

Command Type: VAI Go To Pos (010xh) ▼ ?

Count Nibble (Toggle Bits): 1h ▼
 Auto Increment Count Nibble

Name	Offs.	Description	Scaled Value	Int. Value (Dec)	Int. Value (Hex)
Header	0	010xh: VAI Go To Pos	257	257	0101h
1. Par	2	Target Position	50 mm	500000	0007A120h
2. Par	6	Maximal Velocity	1 m/s	1000000	000F4240h
3. Par	10	Acceleration	10 m/s ²	1000000	000F4240h
4. Par	14	Deceleration	10 m/s ²	1000000	000F4240h

Read Command
Send Command

12.4. Change a Parameter of the Drive with the Parameter Channel Module

Example task: Change the “Maximal Current” (UPID 13A6h) over Profibus while firmware is running

Add module Parameter Channel [4 Word DI/DO]

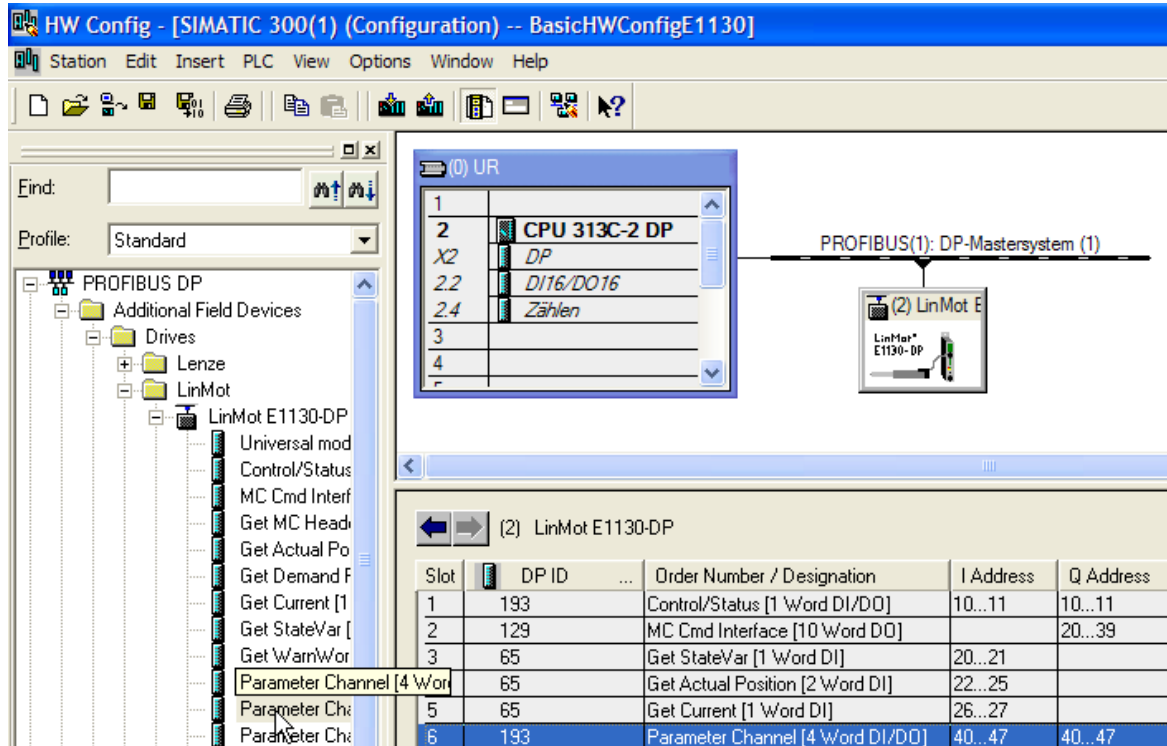

As Command ID use 13h “Write RAM Value of Parameter by UPID”, Command Count 1
 The UPID of “Maximal Current” is 13A6h. The internal scaling of the current value is 0.001A:
 3A (Scaled) = 3000 (Int) = 0000088Bh (HEX)

Word	Description	Value (Hex)
1.	Parameter Channel Control	1301h
2.	Parameter UPID	13A6h
3.	Parameter Value Low	088Bh
4.	Parameter Value High	0000h

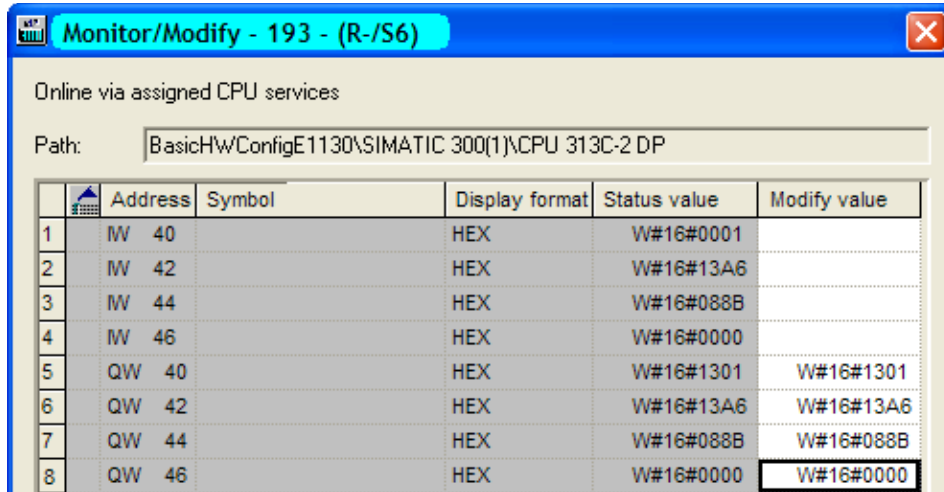

Check if parameter has been changed with LinMot-Talk.

Add a new User Defined variable by clicking on the button UPID and search for the UPID 13A6h

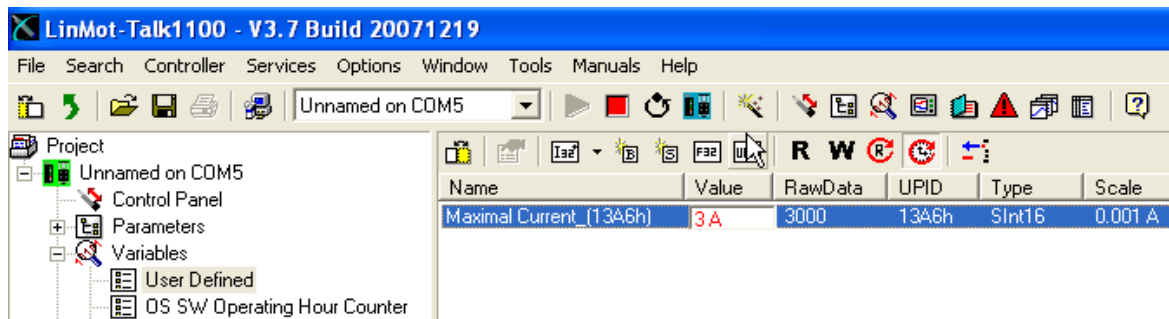

Hint: Consider the Command Count in the Parameter Channel Control. A new command is only evaluated, if the value of the command count changes. In the easiest way bit 0 could be toggled.

13 Troubleshooting

If the PROFIBUS connection is not working, proceed as followed:

- Is the correct firmware installed on the drive? When installing the firmware the PROFIBUS interface must be selected. The actual firmware and configuration software can always be downloaded from <http://www.linmot.com>
- Is the node address correct (attention, the rotary switches are hexadecimal)? The correct setting can be verified with LinMot-Talk in the variables section under \PROFIBUS\Node Address
- The interface switch S3.4 must be ON

S3
ON – OFF
Interface
CAN Term
RS485 Term
RS485/232

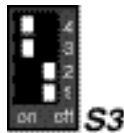

- When using a S7 PLC from Siemens, the “universal module” should never be configured.
- Check if the correct GSD file is used (LINM092D.GSD, which is provided together with LinMot4Talk 4 in the subdirectory. \firmware\PROFIBUS\GSD). NOTE: The drive Series E430-DP and E4030-DP have a different and incompatible GSD file.
- Check bus cabling and termination.

14 Contact Addresses

SWITZERLAND

NTI AG
Bodenaeckerstrasse 2
CH-8957 Spreitenbach

Sales and Administration: +41-(0)56-419 91 91
office@linmot.com

Tech. Support: +41-(0)56-544 71 00
support@linmot.com

Tech. Support (Skype) : <skype:support.linmot>

Fax: +41-(0)56-419 91 92
Web: <http://www.linmot.com>

USA

LinMot USA Inc.
N1922 State Road 120, Unit 1
Lake Geneva, WI 53147

Phone: 262-743-2555

E-Mail: usasales@linmot.com
Web: <http://www.linmotusa.com/>

Please visit <http://www.linmot.com> to find the distribution near you.

Smart solutions are...

