

## Installation Guide Servo Drive

ENG

## C1250-MI

**Important Notice:**

**Please note that we use machine translation to provide documents in your local language. It is possible that not all texts will be translated correctly. If you have any questions or discrepancies regarding the accuracy of the information in the translated version, please read the original English version (0185-1175-E).**

Please visit <http://www.linmot.com> to check for the latest version of this document!

## Content

<b>1</b>	<b>General Information .....</b>	<b>3</b>
1.1	Introduction .....	3
1.2	Explanation of Symbols .....	3
1.3	Qualified Personnel .....	3
1.4	Liability .....	3
1.5	Copyright.....	3
<b>2</b>	<b>Safety Instructions .....</b>	<b>4</b>
<b>3</b>	<b>System Overview.....</b>	<b>6</b>
<b>4</b>	<b>Interfaces.....</b>	<b>7</b>
<b>5</b>	<b>Functionality .....</b>	<b>8</b>
<b>6</b>	<b>Software .....</b>	<b>8</b>
<b>7</b>	<b>Power Supply and Grounding.....</b>	<b>9</b>
<b>8</b>	<b>Calibrated Measuring Amplifier (C1250-MI-XC-xS-Cxx) .....</b>	<b>10</b>
<b>9</b>	<b>Description of the connectors / Interfaces .....</b>	<b>10</b>
9.1	PE .....	10
9.2	X1.....	10
9.3	X2/X3 Motor-Connection .....	11
9.4	X4.....	12
9.5	X13.....	12
9.6	X17 – X18 .....	13
9.7	X19.....	13
9.8	X33.....	13
9.9	S1 – S2 .....	14
9.10	System LEDs .....	14
9.11	RT Bus LED's .....	14
<b>10</b>	<b>System LED Blink Codes .....</b>	<b>15</b>
<b>11</b>	<b>Safety Wiring .....</b>	<b>16</b>
<b>12</b>	<b>Physical Dimension.....</b>	<b>18</b>
<b>13</b>	<b>Power Supply Requirements.....</b>	<b>19</b>
13.1	Motor Power Supply .....	19
13.2	Signal Power Supply.....	19
<b>14</b>	<b>Regeneration.....</b>	<b>19</b>
<b>15</b>	<b>Safety notes for the installation according to UL .....</b>	<b>20</b>
<b>16</b>	<b>Ordering Information.....</b>	<b>21</b>
16.1	Drives.....	21
16.2	Accessories.....	22
<b>17</b>	<b>International Certifications .....</b>	<b>23</b>
17.1	IECEE CB SCHEME – CB test certificate .....	24
17.2	UL Listing.....	27
17.3	EU Declaration of Conformity CE Marking .....	28
17.4	UK Declaration of Conformity UKCA Marking .....	29

## 1 General Information

### 1.1 Introduction

This manual includes instructions for the assembly, installation, maintenance, transport, and storage of the servo drives. The document is intended for electricians, mechanics, service technicians, and warehouse staff. Read this manual before using the product and always observe the general safety instructions and those in the relevant section. Keep these operating instructions in an accessible place and make them available to the personnel assigned.

### 1.2 Explanation of Symbols



Triangular warning signs warn of danger.



Round command symbols tell what to do.

### 1.3 Qualified Personnel

All work such as installation, commissioning, operation, and service of the product may only be carried out by qualified personnel. The personnel must have the necessary qualifications for the corresponding activity and be familiar with the installation, commissioning, operation, and service of the product. The manual and in particular the safety instructions must be carefully read, understood, and observed.

### 1.4 Liability

NTI AG (as manufacturer of LinMot and MagSpring products) excludes all liability for damages and expenses caused by incorrect use of the products. This also applies to false applications, which are caused by NTI AG's own data and notes, for example during sales, support or application activities. It is the responsibility of the user to check the data and information provided by NTI AG for correct applicability in terms of safety. In addition, the entire responsibility for safety-related product functionality lies exclusively with the user. Product warranties are void if products are used with stators, sliders, servo drives, or cables not manufactured by NTI AG unless such use was specifically approved by NTI AG.

NTI AG's warranty is limited to repair or replacement as stated in our standard warranty policy as described in our "terms and conditions" previously supplied to the purchaser of our equipment (please request copy of same if not otherwise available). Further reference is made to our general terms and conditions.

### 1.5 Copyright

This work is protected by copyright.

Under the copyright laws, this publication may not be reproduced or transmitted in any form, electronic or mechanical, including photocopying, recording, microfilm, storing in an information retrieval system, not even for training purposes, or translating, in whole or in part, without the prior written consent of NTI AG.

LinMot® and MagSpring® are registered trademarks of NTI AG.

## 2 Safety Instructions



### For your personal safety

Disregarding the following safety measures can lead to severe injury to persons and damage to material:

- Only use the product as directed.
- Never commission the product in the event of visible damage.
- Never commission the product before assembly has been completed.
- Do not carry out any technical changes on the product.
- Only use the accessories approved for the product.
- Only use original spare parts from LinMot.
- Observe all regulations for the prevention of accidents, directives and laws applicable on site.
- Transport, installation, commissioning, and maintenance work must only be carried out by qualified personnel.
- Observe IEC 364 and CENELEC HD 384 or DIN VDE 0100 and IEC report 664 or DIN VDE 0110 and all national regulations for the prevention of accidents.
- According to the basic safety information, qualified, skilled personnel are persons who are familiar with the assembly, installation, commissioning, and operation of the product and who have the qualifications necessary for their occupation.
- Observe all specifications in this documentation.
- This is the condition for safe and trouble-free operation and the achievement of the specified product features.
- The procedural notes and circuit details described in this documentation are only proposals. It is up to the user to check whether they can be transferred to the applications. NTI AG / LinMot does not accept any liability for the suitability of the procedures and circuit proposals described.
- LinMot servo drives, and the accessory components can include live and moving parts (depending on their type of protection) during operation. Surfaces can be hot.
- Non-authorized removal of the required cover, inappropriate use, incorrect installation, or operation create the risk of severe injury to persons or damage to material assets.
- For more information, please see the documentation.
- High amounts of energy are produced in the drive. Therefore, it is required to wear personal protective equipment (body protection, headgear, eye protection, hand guard).



### Application as directed

- Drives are components, which are designed for installation in electrical systems or machines. They are not to be used as domestic appliances, but only for industrial purposes according to EN 61000-3-2.
- When drives are installed into machines, commissioning (i.e., starting of the operation as directed) is prohibited until it is proven that the machine complies with the regulations of the EC Directive 2006/42/EG (Machinery Directive); EN 60204 must be observed.
- Commissioning (i.e., starting of the operation as directed) is only allowed when there is compliance with the EMC Directive (2014/30/EU).
- The technical data and supply conditions can be obtained from the nameplate and the documentation. They must be strictly observed.



### Transport, storage

- Please observe the notes on transport, storage, and appropriate handling.
- Observe the climatic conditions according to the technical data.

**Installation**

- The drives must be installed and cooled according to the instructions given in the corresponding documentation.
- The ambient air must not exceed degree of pollution 2 according to EN 61800-5-1.
- Ensure proper handling and avoid excessive mechanical stress. Do not bend any components and do not change any insulation distances during transport or handling. Do not touch any electronic components and contacts.
- Drives contain electrostatic sensitive devices, which can easily be damaged by inappropriate handling. Do not damage or destroy any electrical components since this might endanger your health!

**Electrical connection**

- When working on live drives, observe the applicable national regulations for the prevention of accidents.
- The electrical installation must be carried out according to the appropriate regulations (e.g. cable cross-sections, circuit breakers, fuses, PE connection). Additional information can be obtained from the documentation.
- This product can cause high-frequency interferences in non-industrial environments, which can require measures for interference suppression.

**Operation**

- If necessary, systems including drives must be equipped with additional monitoring and protection devices according to the valid safety regulations (e.g. law on technical equipment, regulations for the prevention of accidents). The drives can be adapted to your application. Please observe the corresponding information given in the documentation.
- After the drive has been disconnected from the supply voltage, all live components and power connections must not be touched immediately because capacitors can still be charged. Please observe the corresponding stickers on the drive. All protection covers and doors must be shut during operation.

**Burn Hazard**

The heat sink (housing) of the drive can have an operating temperature of  $> 80\text{ }^{\circ}\text{C}$ : Contact with the heat sink results in burns.

**Caution - Risk of Electric Shock!**

- Before servicing, disconnect supply, wait 5 minutes and measure between PWR+ and PGND to be sure that the capacitors have discharged below 42 VDC.
- The power terminals Ph1+, Ph1-, Ph2+, Ph2- and PWR+ remain live for at least 5 minutes after disconnecting from the power supplies.

**Grounding**

All metal parts that are exposed to contact during any user operation or servicing and likely to become energized shall be reliably connected to the means for grounding.

### 3 System Overview

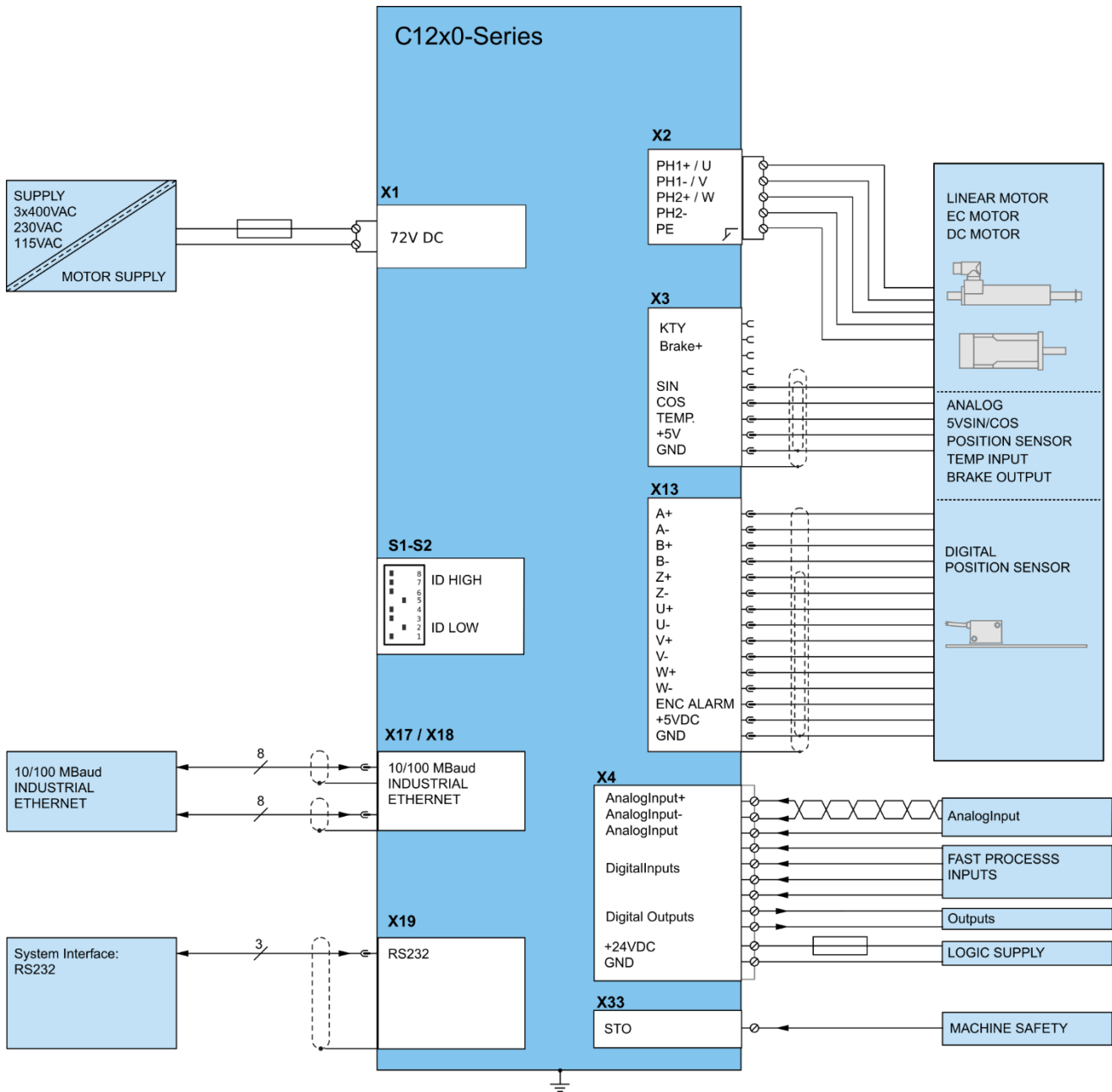

Typical servo system C1250: Servo drive, motor, and power supply

### 4 Interfaces

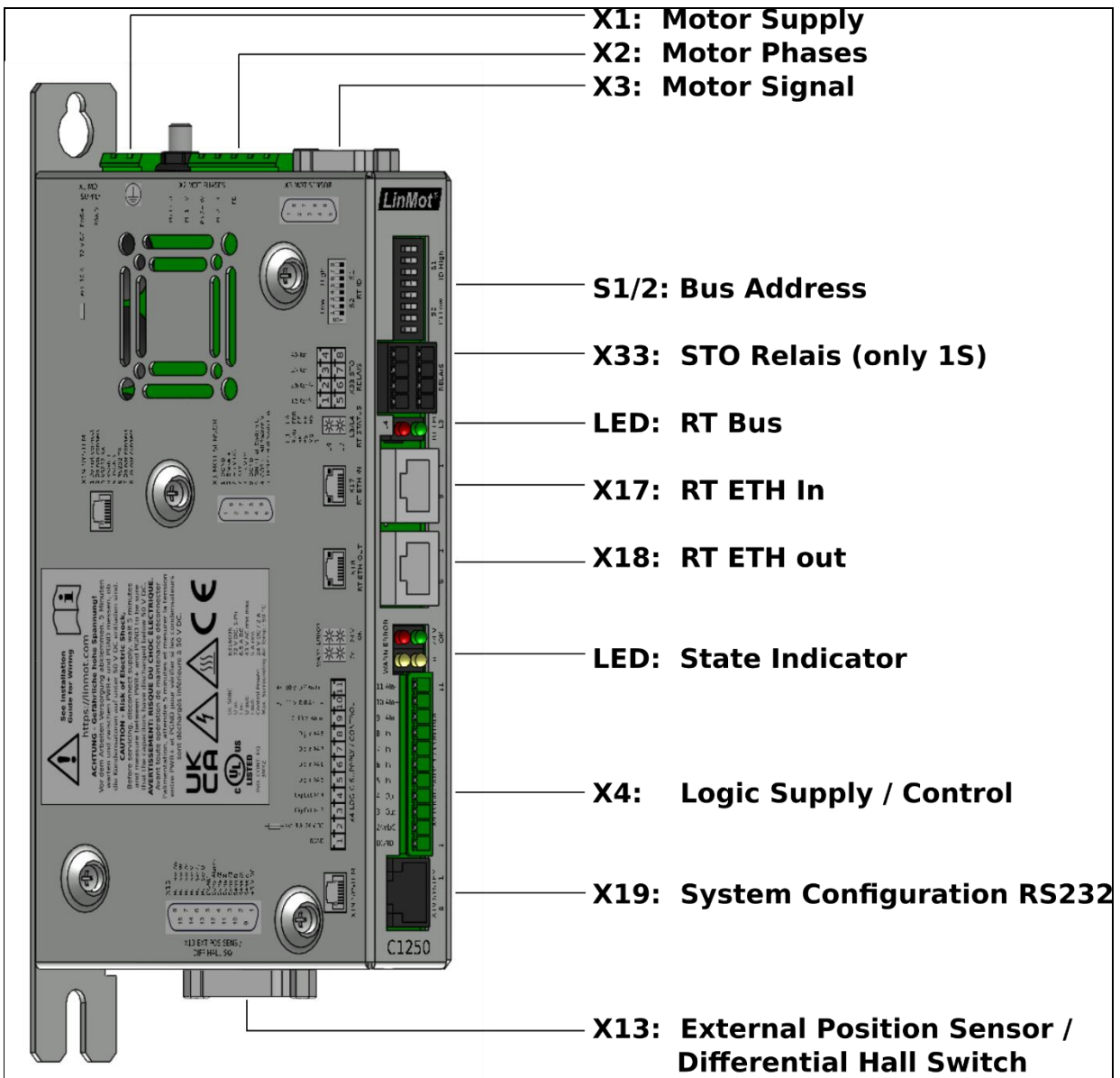

## 5 Functionality

	C1250-MI-XC-0S	C1250-MI-XC-1S
<b>Supply Voltage</b>		
Motor Supply 72 VDC (24...85 VDC)	●	●
Logic Supply 24 VDC (22...26 VDC)	●	●
<b>Motor Phase Current</b>		
25 A peak (0-599 Hz)	●*	●*
<b>Controllable Motors</b>		
LinMot P0x- and PROx- Motors	●	●
Selected motors (contact support)	●	●
Plug and Play (PnP) Auto Configuration	●	●
<b>Command Interface</b>		
POWERLINK CiA402	●	●
PROFINET PROFIdrive (-PN interface of C1250-PN is included)	●	●
Sercos III	●	●
EtherNet/IP with CIP sync (identical to -CM interface)	●	●
LinUDP	●	●
EtherCAT CiA402 (-EC interface of C1250-EC is included)	●	●
EtherCAT SoE	not supported	not supported
CC-Link	●	●
<b>Programmable Motion Profiles (Curves)</b>		
Up to 100 Motion Profiles/ Up to 16302 Curve Points	●	●
<b>Programmable Command Table</b>		
Command Table with up to 255 entries	●	●
<b>External Position Sensor</b>		
Incremental (RS422 up to 25 Mcounts/s)	●	●
Absolute (SSI, BiSS-B, BiSS-C, EnDat2.1, EnDat 2.2)	●	●
<b>Configuration Interface</b>		
RS232	●	●
Ethernet (EoE, etc... depending on Interface)	●	●
<b>Integrated Safety Functions (-1S Option)</b>		
STO (2 Safety Relays)		●
<b>Calibrated Measuring Functions (-Cxx Option)</b>		
Calibrated analog inputs on X4	●**	●**

\* 28 A peak (0-599 Hz) from release 6.12 and later

\*\* only with the C1250-MI-XC-xS-Cxx type

## 6 Software

The configuration software LinMot-Talk is free of charge and can be downloaded from the LinMot homepage.



## 7 Power Supply and Grounding

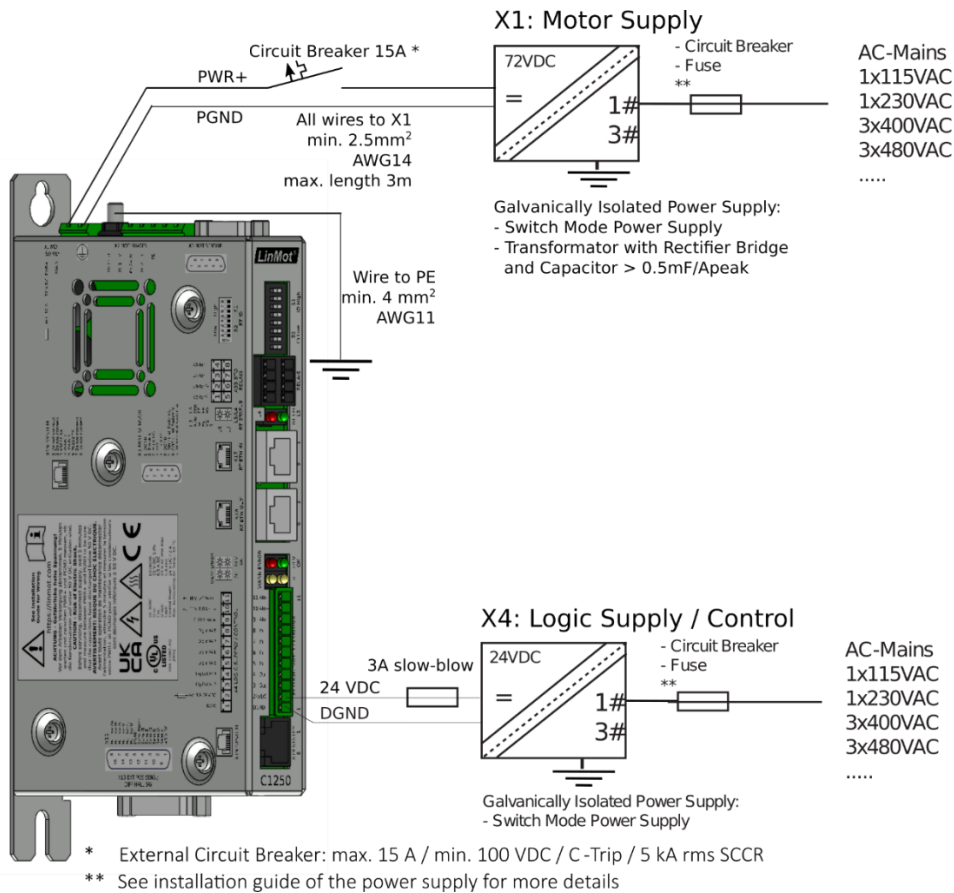

To assure a safe and error free operation, and to avoid severe damage to system components, **all system components must be well grounded to protective earth PE**. This includes both LinMot and all other control system components on the same ground bus.



Each system component<sup>1</sup> should be tied directly to the ground bus (**star pattern**). Daisy chaining from component to component is forbidden. (LinMot motors are properly grounded through their power cables when connected to LinMot drives.)



**Power supply connectors must not be connected or disconnected while DC voltage is present.** Do not disconnect system components until all LinMot drive LEDs have turned off. (Capacitors in the power supply may not fully discharge for several minutes after input voltage has been disconnected). Failure to observe these precautions may result in severe damage to electronic components in LinMot motors and/or drives.



**Do not switch Power Supply DC Voltage.** All power supply switching, and E-Stop breaks should be done to the AC supply voltage of the power supply. Failure to observe these precautions may result in severe damage to the drive.

<sup>1</sup> Inside of the C1250 drive the PWR motor GND and PWR signal GND are connected together and to the GND of the drive housing. It is recommended that the PWR motor GND is NOT grounded at another place than inside of the drive to reduce circular currents.

## 8 Calibrated Measuring Amplifier (C1250-MI-XC-xS-Cxx)

The drives with the ending -Cxx are specially designed for measuring applications. They come with a factory calibration certificate for the analog inputs on X4. The analog inputs on X4 provide a measuring error of less than 1%.

It is the user's responsibility to allow a reasonable period for recalibration. We recommend a calibration interval of 12 months.

## 9 Description of the connectors / Interfaces

### 9.1 PE

PE	Protective Earth
PE	<ul style="list-style-type: none"> <li>Use min. 4 mm<sup>2</sup> (AWG11)</li> <li>Tightening torque: 2 Nm (18 lbin)</li> </ul>

### 9.2 X1

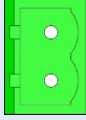
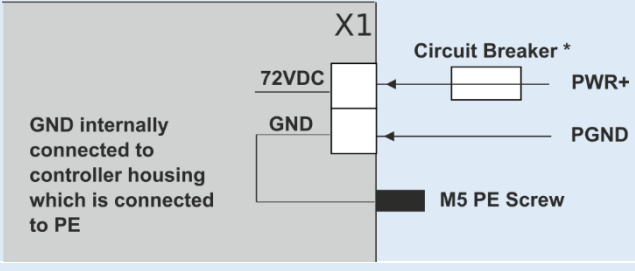
X1	Motor Supply
	
Connector has to be ordered separately: see chapter 16 <b>Ordering Information</b>	Motor Supply: 72 VDC nominal (24...85 VDC) Absolute max. Rating: 72 VDC +20%. External Circuit Breaker: 15 A / min. 100 VDC / C-Trip / 5 kA rms SCCR  If motor supply voltage exceeds 90 VDC, the drive will go into error state. <ul style="list-style-type: none"> <li>Use 60/75 °C copper conductors only</li> <li>Conductor Cross-Section 2.5 mm<sup>2</sup> (AWG14) max Length 3 m</li> </ul>

### 9.3 X2/X3 Motor-Connection

X2	Motor Phases						
	PH1+	LinMot Motor: Motor Phase	1+	Red	3-phase EC-Motor / third-party motor: Motor Phase	U	Red
	PH1	Motor Phase	1-	Pink	Motor Phase	V	Pink
	PH2+	Motor Phase	2+	Blue	Motor Phase	W	Blue
	PH2-	Motor Phase	2-	Grey	Motor Phase	X	Grey
	PE/SCRN	PE			PE		
Connector has to be ordered separately!	<ul style="list-style-type: none"> <li>Use 60/75 °C copper conductors only</li> <li>Conductor cross-section: 0.5 – 2.5 mm<sup>2</sup> (depends on Motor current) / AWG 21 -14</li> </ul>						

X3	Motor Sensor / Brake		
	1	LinMot Motor: Do not connect	EC Motor: DGND
	2	6 Do not connect	Brake+ +5 VDC
	3	7 Do not connect	KTY +5 VDC
	4	8 +5 VDC	DGND
	5	9 Sensor-Sine	Sensor-Sine / Hall Switch U
	Shield	Shield Temp	Sensor-Cosine / Hall Switch V Hall Switch W Shield
DSUB-9 (f)	<p><b>Note:</b></p> <ul style="list-style-type: none"> <li>Use +5 VDC (X3.3) and DGND (X3.8) only for motor internal hall sensor supply (max. 100 mA).</li> <li>Max. motor cable length: 50m for LinMot Px motors. Please check restrictions of motor, encoder and cable as well.</li> <li>Brake+: 24 V / max. 500 mA, peak 1.4 A (will shut down if exceeded) the other terminal has to be wired to DGND (X3.1)</li> </ul> <p><b>Caution:</b></p> <ul style="list-style-type: none"> <li>Do NOT connect DGND (X3.8) to ground or earth!</li> </ul> <p><b>Temperature Sensor:</b></p> <ul style="list-style-type: none"> <li>A resistive temperature sensor (PT1000, KTY) could be connected between +5 VDC (X3.2) and KTY (X3.7)</li> </ul>		

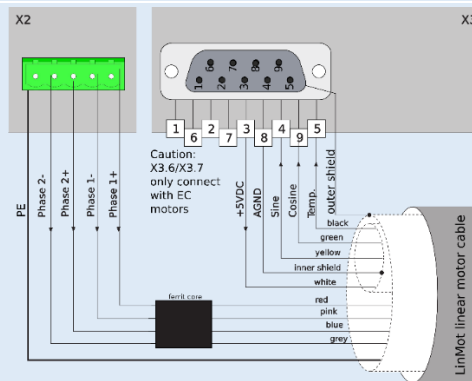

**Important Notes:**

Use Y-style motor cables only (for example K15-Y/C)! A W-style cable has a different shielding, so it cannot be modified to a Y-style cable!

### 9.4 X4

X4		Logic Supply / IO Connection			
	11	AnIn-	X4.11	Configurable differential analog Input (with X4.10)	
	10	AnIn+	X4.10	Configurable differential analog Input (with X4.11)	
	9	AnIn	X4.9	Configurable single ended analog Input	
	8	IN	X4.8	Configurable digital Input	
	7	IN	X4.7	Configurable digital Input	
	6	IN	X4.6	Configurable digital Input	
	5	IN	X4.5	Configurable digital Input	
	4	OUT	X4.4	Configurable digital Output	
	3	OUT	X4.3	Configurable digital Output	
	2	+24VDC	Power Supply	Logic Supply 22-26 VDC	
	1	DGND	Power Supply	Logic Ground	
<p>Spring cage connector (has to be ordered separately: see chapter 16 <b>Ordering Information</b>)</p>	<p><b>Digital inputs</b> (X4.5 ... X4.8): 24 VDC / 5 mA (Low Level: -0.5 to 5 VDC, High Level: 15 to 30 VDC)</p> <p><b>Digital outputs</b> (X4.3 &amp; X4.4): 24 VDC / max. 500 mA, peak 1.4 A (will shut down if exceeded)</p> <p>X4.3: Can be used as brake output for LinMot motors</p> <p>Both outputs are high side switching with integrated pull-down (1k7 to DGND)</p> <p><b>Analog inputs:</b> 12 bit A/D converted</p> <p>X4.9: 0..10 V, input resistance: &gt;75 kΩ to DGND</p> <p>X4.10/X4.11: +/- 10 V, input resistance 28.0 kΩ, common mode range: -5..+10 V to DGND,</p> <p><b>Mating connector (Art. Nr. 0150-3447):</b></p> <ul style="list-style-type: none"> <li>• Use 60/75 °C copper conductors only</li> <li>• Conductor cross-section max. 1.5 mm<sup>2</sup></li> <li>• Stripping length: 11.5 mm</li> </ul> <p><b>Important notes:</b></p> <p>The 24 VDC logic supply for the control circuit (X4.2) must be protected with an external fuse (3 A slow blow)</p>				

### 9.5 X13

X13		External Position Sensor Differential Hall Switches		
	1		<b>ABZ with Hall Switches</b>	<b>SSI / BiSS-B / BiSS-C / EnDat2.1 / EnDat2.2</b>
		9	+5V DC	+5V DC
	2		A+	A+ (optional)
		10	A-	A- (optional)
	3		B+	B+ (optional)
		11	B-	B- (optional)
	4		Z+	DATA+
		12	Z-	DATA-
	5		Encoder Alarm (optional)	Encoder Alarm (optional)
		13	DGND	DGND
	6		U+	nc
		14	U-	nc
	7		V+	nc
		15	V-	nc
	8		W+	Clk+
		W-	Clk-	
case		Shield	Shield	
DSUB-15 (f)	<p><u>Position Encoder Inputs (RS422):</u></p> <p>Max. counting frequency: 25 M counts/s with quadrature decoding.</p> <p>A minimum of 40 ns edge separation must be guaranteed by the encoder under any circumstances!</p> <p>The maximal frequency of each signal is 6.25 MHz.</p> <p><u>Differential Hall Switch Inputs (RS422):</u></p> <p>Input Frequency: &lt; 1 kHz</p> <p><u>Enc. Alarm In:</u></p> <p>5 V / 1 mA</p> <p><u>Sensor Supply:</u></p> <p>5 VDC max. 300 mA</p>			

### 9.6 X17 – X18

X17 – X18		RealTime Ethernet 10/100 Mbit/s	
	X17 RT ETH In	Specification depends on RT Bus. Please refer to the according documentation.	
	X18 RT ETH Out		
RJ-45			

### 9.7 X19

X19		System	
	1	(Do not connect)	
	2	(Do not connect)	
	3	RS232 Rx	
	4	GND	
	5	GND	
	6	RS232 Tx	
	7	(Do not connect)	
	8	(Do not connect)	
	Shield	Shield	
RJ-45		Use isolated USB-RS232 converter (Art.-No. 0150-2473) for configuration over RS232	

### 9.8 X33

X33		Safety Relays (only with the -1S option)		
X33.4/8 Ksr+ X33.3/7 Ksr- X33.2/6 Ksr f+ X33.1/5 Ksr f-		4 / 8	Ksr +	Safety Relay 1 / 2 Input positive
		3 / 7	Ksr -	Safety Relay 1 / 2 Input negative
		2 / 6	Ksr f+	Safety Relay 1 / 2 feedback positive
		1 / 5	Ksr f-	Safety Relay 1 / 2 feedback negative
Spring cage connector (has to be ordered separately: see chapter 16 <b>Ordering Information</b> )		- Use 60/75°C copper conductors only - Conductor cross-section max. 1.5mm <sup>2</sup> - Stripping length: 10mm - The state of the feedback contacts has to be checked after each change of the state of the control contacts! - <b>Max. current on the feedback contacts (Ksr+ and Ksr-) has to be limited below 1 A.</b> - <b>Never connect the safety relays to the logic supply of the drive!</b> → For detailed information see chapter 11 <b>Safety Wiring</b> .		

### 9.9 S1 – S2

S1 – S2	Address Selectors	
	S1 (5..8)	Bus ID High (0 ... F). Bit 5 is the LSB, bit 8 the MSB.
	S2 (1..4)	Bus ID Low (0 ... F). Bit 1 is the LSB, bit 4 the MSB.
<b>Setting the ID high &amp; low to 0xFF resets the drive to manufacturer settings!</b>		
The use of these switches depends on the type of fieldbus which is used. Please see the corresponding manual for further information.		

### 9.10 System LEDs

LEDs	State Displays		
	<b>Signal:</b>	<b>Color:</b>	<b>Description:</b>
	24VOK	Green	24 VDC Logic Supply OK
	EN (enable)	Yellow	Motor Enabled / Error Code Low Nibble
	WARN	Yellow	Warning / Error Code High Nibble
	ERROR	Red	Error

### 9.11 RT Bus LED's

RT Bus LEDs	RT Bus State Display		
	<b>BUS Type:</b>	<b>L3 (bicolour)</b>	<b>L4 (bicolour)</b>
	EtherCAT	RUN (green)	ERR (red)
	PROFINET	SF (red)	BF (red)
	POWERLINK	BS (green)	BE (red)
	EtherNet/IP	MS (green/red)	NS (green/red)
	SERCOS	S (green/red)	
	CC-Link	RUN (green)	ERR (red)

The blink codes are described in the corresponding interface manuals.

## 10 System LED Blink Codes

LED Blink Codes			
Error   24VOK Warn   EN			
ERROR	WARN	EN (enable)	Description
OFF	Warning	Operation Enabled	<b>Normal Operation:</b> Warnings and operation enabled are displayed.
ON	<ul style="list-style-type: none"> <li>• ~2 Hz</li> <li>0..15 x Error Code High Nibble</li> </ul>	<ul style="list-style-type: none"> <li>• ~2 Hz</li> <li>0..15 x Error Code Low Nibble</li> </ul>	<b>Error:</b> The error code is shown by a blink code with "WARN" and "EN". The error byte is divided into low and high nibble (= 4 bit). "WARN" and "EN" are blinking together. The error can be acknowledged. (e.g.: WARN blinks 3x, EN blinks 2x; Error Code = 32h)
<ul style="list-style-type: none"> <li>• ~2 Hz</li> </ul>	<ul style="list-style-type: none"> <li>• ~2 Hz</li> <li>0..15 x Error Code High Nibble</li> </ul>	<ul style="list-style-type: none"> <li>• ~2 Hz</li> <li>0..15 x Error Code Low Nibble</li> </ul>	<b>Fatal Error:</b> The error code is shown by a blink code with "WARN" and "EN". The error byte is divided into low and high nibble. "WARN" and "EN" are blinking together. Fatal errors can only be acknowledged by a reset or power cycle. (e.g.: WARN blinks 3x, EN blinks 2x; Error Code = 32h)
<ul style="list-style-type: none"> <li>• ~4 Hz</li> </ul>	<ul style="list-style-type: none"> <li>• ~2 Hz</li> <li>0..15 x Error Code High Nibble</li> </ul>	<ul style="list-style-type: none"> <li>• ~2 Hz</li> <li>0..15 x Error Code Low Nibble</li> </ul>	<b>System Error:</b> Please reinstall firmware or contact support.
<ul style="list-style-type: none"> <li>• ~0.5 Hz</li> </ul>	<ul style="list-style-type: none"> <li>• ~0.5 Hz</li> </ul>	Off	<b>Signal Supply 24V too low:</b> The error and warn LEDs blink alternating if the signal supply +24 VDC (X4.2) is less than 18 VDC.
Off	○●●●	●○●●	<b>Plug&amp;Play Communication Active:</b> This sequence (Warn on, then En on, then both off, complete sequence of the 4 states ca. 1 s) signalizes the state when the plug and play parameters are being read from the motor.
<ul style="list-style-type: none"> <li>○●</li> <li>~4 Hz</li> </ul>	<ul style="list-style-type: none"> <li>●○</li> <li>~4 Hz</li> </ul>	Off	<b>Waiting for Defaulting Parameters:</b> When ID (S1, S2) is set to 0xFF, the drive starts up in a special mode and the Error and Warn LED blink alternating ~4 Hz. When the ID ist set to 0x00, all parameters will be set to their default value. To leave this state, power down the drive and change the ID. Also see in the Usermanual_LinMot-Talk under chapter trouble shooting.
Off	<ul style="list-style-type: none"> <li>○●</li> <li>~2 Hz</li> </ul>	<ul style="list-style-type: none"> <li>○●</li> <li>~2 Hz</li> </ul>	<b>Defaulting Parameters Done:</b> When the parameters have set to their default values (initiated via S1/S2 on power up) the Warn and EN LEDs blink together at 2 Hz. To leave this state, power down the drive. Also see in the Usermanual_LinMot-Talk under chapter trouble shooting.

The meaning of the error codes can be found in the *Usermanual\_MotionCtrl\_Software\_SG5-SG7* and the user manual of the installed interface software. These documents are provided together with LinMot-Talk configuration software and can be downloaded from [www.linmot.com](http://www.linmot.com).

## 11 Safety Wiring

The C1250 drives with the -1S option have internal safety functions:

Two Safety relays Ksr in series, which support the supply voltage for the motor drivers (n.o.). There is also a feedback contacts for each relay (n.c.).

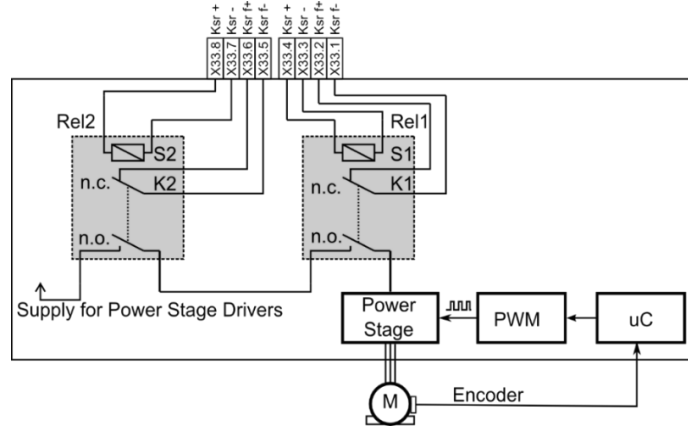

To enable the -1S drives both relays must be switched on.

Minimal wiring:

- Connect X33.8 and X33.4 to 24 VDC (from safety-supply)
- Connect X33.7 and X33.3 to GND (from safety-supply)



**Never connect X33.8 and X33.4 to the logic supply of X4!  
Never disconnect X33 when the STO is powered!**



**The overvoltage protection must be provided externally and sized according to the safety circuit of the machine (The voltage on any pin of X33 must be limited below 100V referenced to DGND)!**



**The drop out time of the relays is depending on the external circuitry!**

Safety Relay Ksr	
Nominal voltage	24 VDC
Min. pick-up voltage at 20°C	≤ 16.8 V
Drop-out voltage at 20°C	≥ 2.4 V
Drop-out time (no protection circuit)	Typically 3 ms
Coil resistance at 20°C	2'100 Ω ± 10%
Type	EN 50205, type A Relay with forcibly guided contacts according to IEC 61810-3
Contact lifetime	> 10'000'000
Manufacturer and type	Elesta relays / SIS112 24VDC
Maximum current on feedback contacts (Ksr f+ and Ksr-)	< 1 A

Drive Classification according EN ISO 13849-1 (safety of machinery)	
Category	cat. = 3
Performance Level	PL = d
Diagnostic Coverage	DC = high (99%)
Mean Time to hazardous failure of one channel	MTTF <sub>d</sub> = high (100 years typically, see calculation example below)

DC (Diagnostic Coverage) is high (99%) assuming that the state of the feedback contacts is checked after each change of the state of the control contacts.



The  $MTTF_d$  mainly depends on the number of operations of the safety relays.

**Example calculation of  $MTTF_d$ :**

Assuming that the safety function is requested every 20 s on a machine running 24 h per day and 7 days per week.

$$B_{10} = 10'000'000$$

$$B_{10d} = 20'000'000 \text{ (according EN ISO 13849-1:2008 table C.1)}$$

$$n_{op} = (24 \text{ h/day} * 365.25 \text{ days/year} * 3600 \text{ s/h}) / 20 \text{ s} = 1'577'880 \text{ operations per year}$$

$$MTTF_d = B_{10d} / (0.1 * n_{op}) = 126.75 \text{ years}$$

(This has to be limited to 100 years according to the standard for further calculations)

$$= \text{high (100 years)}$$

## 12 Physical Dimension

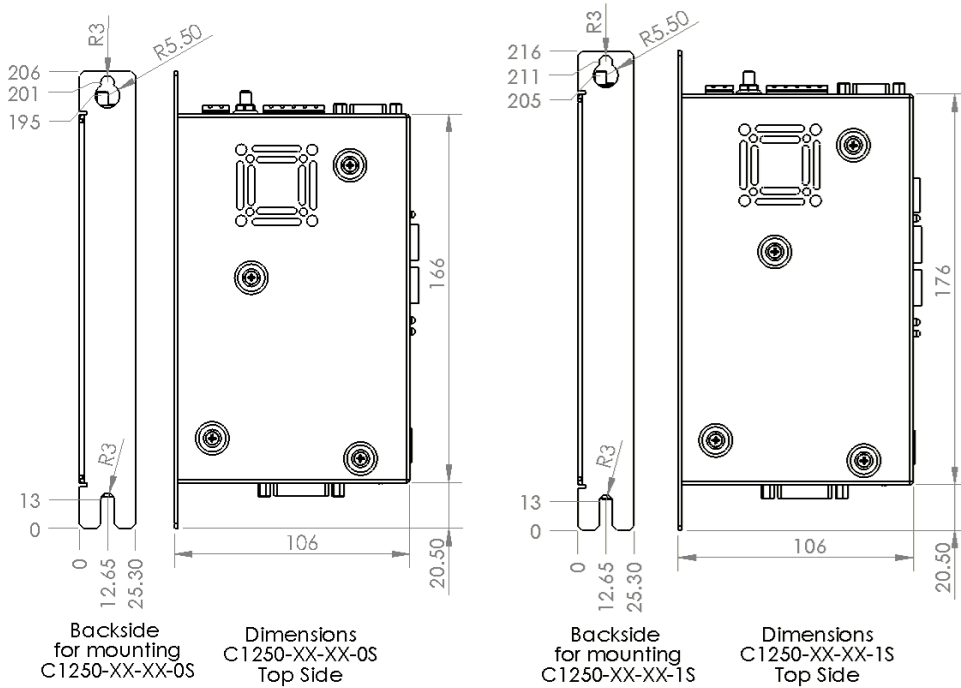

C1250-MI Series single axis drive		C1250-MI-XC-0S	C1250-MI-XC-1S
Width	mm (in)	25.3 (1.0)	
Height	mm (in)	166 (6.54)	176 (6.93)
Height with fixings	mm (in)	206 (8.11)	216 (8.50)
Depth	mm (in)	106 (4.2)	
Weight	g (lb)	630 (1.4)	700 (1.54)
Mounting Screws		2 x M5	
Mounting Distance	mm (in)	198 (7.80)	
Case, Degree of Protection	IP	20	
Storage Temperature	°C	-25...40	
Transport Temperature	°C	-25...70	
Operating Temperature	°C	0...40 at rated data (40...50 with power derating *)	
Relative humidity		< 95% (non-condensing)	
Pollution	IEC/EN 60664-1	Pollution degree 2	
Shock resistance (16ms)	-1S option		3.5g
Vibration resistance (10-200Hz)	-1S option		1g
Max. Case Temperature	°C	70	
Max. Power Dissipation	W	30	
Mounting place		In the control cabinet (at least IP54)	
Mounting position		Vertical	
Distance between Drives	mm (in)	Without Power Derating *: 20 (0.8) horizontal / 50 (2) vertical With Power Derating *: 5 (0.2) horizontal / 20 (0.8) vertical	

\* The derating is depending on the situation in the cabinet. The temperature of the drive should be checked under full load (the temperature should be stable, which may take an hour or more). This allows to verify that enough margin is there if the cabinet goes to the maximum allowable temperature of 40° C. For example, if the drive temperature reaches 45° C and the cabinet temperature is 30° C, this would result in a drive temperature of about 55° C at a cabinet temperature of 40° C. The warning level of the drive is configured by default to 75° C and the error level to 80° C. In this example, everything is fine. If the drive temperature is long time above the warning level, this might result in a reduced lifetime of the drive.

## 13 Power Supply Requirements

### 13.1 Motor-Power Supply

The calculation of the needed power for the Motor supply is depending on the application and the used motor.

The nominal supply voltage is 72 VDC.

The possible range is from 24 to 85 VDC.



The motor supply can rise to 95 VDC when braking. This means that everything connected to that power supply needs a dielectric withstand voltage of at least 100 VDC. (Additional capacitors, etc...). Due to high braking voltage and sudden load variations of linear motor applications, **only compatible power supplies can be used (see chapter 16 Ordering Information).**

### 13.2 Signal-Power Supply

The logic supply needs a regulated power supply of a nominal voltage of 24 VDC. The voltage must be between 22 and 26 VDC.

Current provided from the logic-supply:

- min. 0.5 A (no load on the outputs)
- typ. 0.7 A (all 2 outputs "on" with 100 mA load and brake with no load)
- max. 2.0 A (all 2 outputs "on" with 500 mA peak load and brake with 500 mA peak load)



**Do not connect the safety relays to the 24 VDC Signal Supply!  
Use a separate power supply for the safety circuit**



**The 24 VDC supply for the control circuit must be protected with an external fuse (3 A slow blow)**

## 14 Regeneration

If the power supply rises too high during braking, connect an additional capacitor to the motor power supply.

It is recommended to use a capacitor  $\geq 10'000 \mu\text{F}$  (install capacitor close to the drive supply!).

## 15 Safety notes for the installation according to UL

### Markings:

- Wiring terminal markings:  
See markings on the enclosure and the corresponding chapters in the installation guide!
- Cautionary Marking:  
See markings on the enclosure and the corresponding chapters in the installation guide!
- The transients must be limited to max. 0.8 kV on the line side of the drive.
- The 24 VDC supply for the control circuit must be protected with an external UL Listed 3 A DC fuse.
- **A separate 24 VDC power supply protected with an external UL Listed 3 A fuse connected to the output of the power supply must be used to protect the secondary control circuit (safety relays on X33)**
- Integral solid state short circuit protection does not provide branch circuit protection. Branch circuit protection must be provided in accordance with the National Electrical Code and any additional local codes.

### Markings for cULus:

- Ratings:
  - Input Voltage: 72 VDC
  - Input current: 6.5 A
  - Output Voltage: 43 V rms
  - Output Current: 5 A rms
  - Number of Phases: 2 - 3
  - Frequency range: 0-599 Hz
  - Duty cycle rating: 4 - 96%
  - Relays (only for -1S variant):
    - Rated Contacts: max. 24 VDC, 6 A
    - Coil: 24 VDC
    - Surrounding air temp: max. 85 °C
  - Control Power (X4.2): 24 VDC (Protected with an external UL Listed 3 A fuse)
  - Surrounding Air Temperature: max. 50 °C
- Suitable for use on a circuit capable of delivering not more than 5 kADC, 72 VDC maximum.  
(Branch circuit protection on X1: External Circuit Breaker: 15 A / min. 100 VDC / C-Trip / 5 kA rms SCCR)

## 16 Ordering Information

### 16.1 Drives

Drives	Description	Art. No.
C1250-MI-XC-0S-000	Multi Interface Drive (72V/25A)	<a href="#">0150-5591</a>
C1250-MI-XC-1S-000	Multi Interface Drive (72V/25A), STO	<a href="#">0150-5589</a>
C1250-MI-XC-1S-OPD	Multi Interface Drive (72V/25A), STO, PROFINET/PROFIdrive installed	<a href="#">0150-5732</a>
C1250-MI-XC-1S-OCM	Multi Interface Drive (72V/25A), STO, EtherNet/IP CIP Sync installed	<a href="#">0150-5733</a>
C1250-MI-XC-1S-OLU	Multi Interface Drive (72V/25A), STO, LinUDP installed	<a href="#">0150-5734</a>
C1250-MI-XC-1S-OPL	Multi Interface Drive (72V/25A), STO, POWERLINK installed	<a href="#">0150-5735</a>
C1250-MI-XC-1S-OSC	Multi Interface Drive (72V/25A), STO, Sercos III installed	<a href="#">0150-5736</a>
C1250-MI-XC-1S-ODS	Multi Interface Drive (72V/25A), STO, EtherCAT/CiA402 installed	<a href="#">0150-5737</a>
C1250-MI-XC-1S-OCC	Multi Interface Drive (72V/25A), STO, CC-Link installed	<a href="#">0150-5738</a>
C1250-MI-XC-0S-OPD	Multi Interface Drive (72V/25A), PROFINET/PROFIdrive installed	<a href="#">0150-5746</a>
C1250-MI-XC-0S-OCM	Multi Interface Drive (72V/25A), EtherNet/IP CIP Sync installed	<a href="#">0150-5747</a>
C1250-MI-XC-0S-OLU	Multi Interface Drive (72V/25A), LinUDP installed	<a href="#">0150-5748</a>
C1250-MI-XC-0S-OPL	Multi Interface Drive (72V/25A), POWERLINK installed	<a href="#">0150-5749</a>
C1250-MI-XC-0S-OSC	Multi Interface Drive (72V/25A), Sercos III installed	<a href="#">0150-5750</a>
C1250-MI-XC-0S-ODS	Multi Interface Drive (72V/25A), EtherCAT/CiA402 installed	<a href="#">0150-5751</a>
C1250-MI-XC-0S-OCC	Multi Interface Drive (72V/25A), CC-Link installed	<a href="#">0150-5752</a>
Calibrated Drives	Description	Art. No.
C1250-MI-XC-0S-C00	Multi Interface Drive (72V/25A), Calibrated Measuring Amplifier	<a href="#">0150-5592</a>
C1250-MI-XC-1S-C00	Multi Interface Drive (72V/25A), STO, Calibrated Measuring Amplifier	<a href="#">0150-5590</a>
C1250-MI-XC-1S-CPD	Multi Interface Drive (72V/25A), STO, Calibrated, PROFINET/PROFIdrive installed	<a href="#">0150-5725</a>
C1250-MI-XC-1S-CCM	Multi Interface Drive (72V/25A), STO, Calibrated, EtherNet/IP CIP Sync installed	<a href="#">0150-5726</a>
C1250-MI-XC-1S-CLU	Multi Interface Drive (72V/25A), STO, Calibrated, LinUDP installed	<a href="#">0150-5727</a>
C1250-MI-XC-1S-CPL	Multi Interface Drive (72V/25A), STO, Calibrated, POWERLINK installed	<a href="#">0150-5728</a>
C1250-MI-XC-1S-CSC	Multi Interface Drive (72V/25A), STO, Calibrated, Sercos III installed	<a href="#">0150-5729</a>
C1250-MI-XC-1S-CDS	Multi Interface Drive (72V/25A), STO, Calibrated, EtherCAT/CiA402 installed	<a href="#">0150-5730</a>
C1250-MI-XC-1S-CCC	Multi Interface Drive (72V/25A), STO, Calibrated, CC-Link installed	<a href="#">0150-5731</a>
C1250-MI-XC-0S-CPD	Multi Interface Drive (72V/25A), Calibrated, PROFINET/PROFIdrive installed	<a href="#">0150-5739</a>
C1250-MI-XC-0S-CCM	Multi Interface Drive (72V/25A), Calibrated, EtherNet/IP CIP Sync installed	<a href="#">0150-5740</a>
C1250-MI-XC-0S-CLU	Multi Interface Drive (72V/25A), Calibrated, LinUDP installed	<a href="#">0150-5741</a>
C1250-MI-XC-0S-CPL	Multi Interface Drive (72V/25A), Calibrated, POWERLINK installed	<a href="#">0150-5742</a>
C1250-MI-XC-0S-CSC	Multi Interface Drive (72V/25A), Calibrated, Sercos III installed	<a href="#">0150-5743</a>
C1250-MI-XC-0S-CDS	Multi Interface Drive (72V/25A), Calibrated, EtherCAT/CiA402 installed	<a href="#">0150-5744</a>
C1250-MI-XC-0S-CCC	Multi Interface Drive (72V/25A), Calibrated, CC-Link installed	<a href="#">0150-5745</a>

There are drives with a certain interface preinstalled. On the -MI drives can nevertheless every available interface be installed. This can be done during firmware installation.

## 16.2 Accessories

Accessories	Description	Art. No.
<b>DC01-C1X00-0S/X1/X4</b>	<b>Drive Connector Set for C1X00-0S</b>	<b><u>0150-3527</u></b>
<b>DC01-C1X00-1S/X1/X4/X33</b>	<b>Drive Connector Set for C1X00-1S</b>	<b><u>0150-3528</u></b>
DC01-C1X00/X1	Drive Connector for PWR 72 VDC Input	<u>0150-3525</u>
DC01-C1X00/X2	Drive Connector Motor Phases	<u>0150-3526</u>
DC01-Signal/X4	Drive Connector 24 VDC & Logic	<u>0150-3447</u>
DC01-Safety/X33	Drive Connector Safety	<u>0150-3451</u>
<b>Isolated USB-RS232 converter</b>	<b>Isolated USB RS232 converter with config. cable</b>	<b><u>0150-2473</u></b>
Isolated USB-serial converter	Isolated USB RS232/422/485 converter	<u>0150-3120</u>
Recalibration Service	Calibration Drive Series C1200 (Calibration of analog inputs on X4 of C1250-xx-XC-xS-Cxx Drives)	<u>0150-4164</u>
Compatible Power Supplies		Art. No.
S02-72/1000	Power Supply 72 V/1000 W, 3x400-480 VAC	<u>0150-4535</u>
S01-72/1000	Power Supply 72 V/1000 W, 3x340-550 VAC	<u>0150-1872</u>
S01-72/500	Power Supply 72 V/500 W, 1x120/230 VAC	<u>0150-1874</u>
S01-24/500	Power Supply 24 V/500 W, 1x120/230 VAC	<u>0150-2480</u>
S01-48/300	Power Supply 48 V/300 W, 1x120/230 VAC	<u>0150-1941</u>
S01-48/600	Power Supply 48 V/600 W, 1x120/230 VAC	<u>0150-1946</u>
T01-72/420-Multi	T-Supply 72 V / 420 VA, 3x230/400/480 VAC	<u>0150-1869</u>
T01-72/900-Multi	T-Supply 900 VA, 3x230/400/480 VAC	<u>0150-1870</u>
T01-72/1500-Multi	T-Supply 1500 VA, 3x230/400/480 VAC	<u>0150-1871</u>
T01-72/420 -1ph	T-Supply 420 VA, 1x208/220/230/240 VAC	<u>0150-1859</u>

Bold items are strongly recommended accessories!







The connectors must be ordered separately and are not included with the drive!





Use 0150-2473 (isolated USB RS232 converter) for configuration!

## 17 International Certifications

Certifications	
Europe 	See chapter 17.3 EU Declaration of Conformity CE Marking
UK 	See chapter 17.4 UK Declaration of Conformity UKCA Marking
	Ref. Certif. No. CH-11687
USA / Canada 	<p>All products marked with this symbol are tested and listed by Underwriters Laboratories and the production facilities are checked quarterly by an UL inspector. This mark is valid for the USA and Canada and eases certification of your machines and systems in these areas.</p> <p>File number E316095</p> <p>UL 508C Power Conversion Equipment</p> <p>CSA C22.2 Industrial Control Equipment</p> <p>See chapter 17.2 UL Listing</p>

17.1 IECEE CB SCHEME – CB test certificate

		Ref. Certif. No. <b>CH-11687</b>
IEC SYSTEM FOR MUTUAL RECOGNITION OF TEST CERTIFICATES FOR ELECTRICAL EQUIPMENT (IECEE) CB SCHEME		
<h3>CB TEST CERTIFICATE</h3>		
Product	C1250-MI Servo Drive Series	
Name and address of the applicant	NTI AG Bodenaeckerstrasse 2, 8957 Spreitenbach Switzerland	
Name and address of the manufacturer	NTI AG Bodenaeckerstrasse 2, 8957 Spreitenbach Switzerland	
Name and address of the factory <small>Note: When more than one factory, please report on page 2</small>	NTI AG Bodenaeckerstrasse 2, 8957 Spreitenbach Switzerland	
Ratings and principal characteristics	24 VDC, max. 2 A / 72 VDC, 6.5 A	
Trademark / Brand (if any)	LinMot	
Customer Test Facility (CTF) Stage used	./.	
Model / Type Ref.	C1250-MI-XC-xS-yyy	
Additional information (if necessary may also be reported on page 2)	National Differences specified in the CB Test Report	
A sample of the product was tested and found to be in conformity with	See page 2	
As shown in the Test Report Ref. No. which forms part of this Certificate	EMCKP5197A	
This CB Test Certificate is issued by the National Certification Body		
	Eurofins Electric & Electronic Product Testing AG Luppenstrasse 3 8320 Fehraltorf SWITZERLAND	
Date: 2022-08-03	Signature: Martin Plüss 	

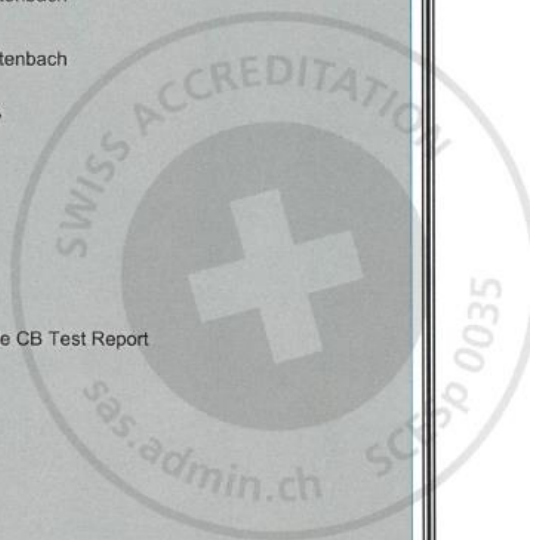

T01\_V04



	Ref. Certif. No.
	<b>CH-11687</b>

**Additional information**

A sample of the product was tested and found to be in conformity with

- CISPR 11:2015
- CISPR 11:2015/AMD1:2016
- CISPR 11:2015/AMD2:2019
- CISPR 32:2015
- CISPR 32:2015/AMD1:2019
- IEC 61000-3-2:2018
- IEC 61000-3-2:2018/AMD1:2020
- IEC 61000-3-3:2013
- IEC 61000-3-3:2013/AMD1:2017
- IEC 61000-3-3:2013/AMD2:2021
- IEC 61800-3:2017

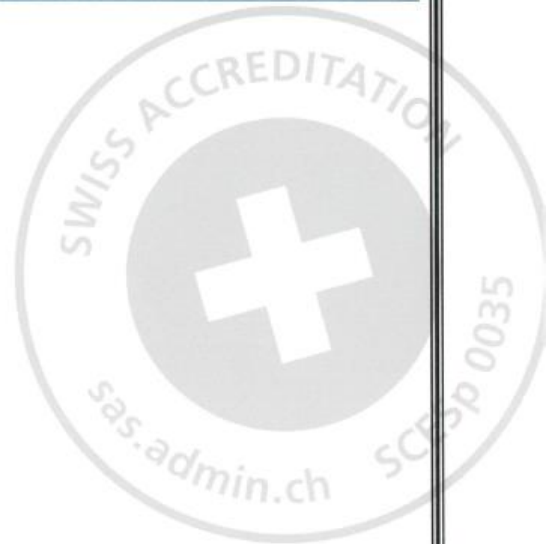

This CB Test Certificate is issued by the National Certification Body



**Eurofins Electric & Electronic Product Testing AG**  
Luppenstrasse 3  
8320 Fehraltorf  
SWITZERLAND

Date: 2022-08-03

Signature: Martin Plüss

**Summary of compliance with Group and National Differences (List of countries addressed):**

The product fulfils the requirements of the corresponding EN standards  
Countries addressed: CENELEC

EN IEC 61800-3:2018

EN 55011:2016+A1:2017+A11:2020+A2:2021 class A

EN 55032:2015+A1:2020+A11:2020 class A

EN 61000-3-2:2014

EN IEC 61000-3-2:2019+A1:2021

EN 61000-3-3:2013+A1:2019+A2:2021

**Summary of compliance with other IEC standards:**

The product fulfils the requirements of the following additional IEC standards:

CISPR 11:2015 class A

CISPR 11:2015/AMD1:2016 class A

CISPR 11:2015/AMD2:2019 class A

CISPR 32:2015 class A

CISPR 32:2015/AMD1:2019 class A

IEC 61000-3-2:2018 (ed.5)

IEC 61000-3-2:2018/AMD1:2020

IEC 61000-3-3:2013 (ed.3)

IEC 61000-3-3:2013/AMD1:2017

IEC 61000-3-3:2013/AMD2:2021

## 17.2 UL Listing

**CERTIFICATE OF COMPLIANCE**

**Certificate Number** E316095  
**Report Reference** E316095-20190630  
**Issue Date** 2020-FEBRUARY-28

**Issued to:** NTI AG  
Bodenaeckerstr 2  
8957 SPREITENBACH SWITZERLAND

**This certificate confirms that  
representative samples of**

**POWER CONVERSION EQUIPMENT**

Open type Power Conversion Equipment, model C, may be followed by P, followed by 12, followed by 00, 30, 50 or 51, followed by -, followed by GP, PL, PN, SC, IP, EC, SE, PD, DP, VA, CO, CD, MI, DN, DS, CC, CM, or LU, followed by -, followed by XC, followed by -0S or -1S, may be followed by – and any characters which describe software non-critical features

Have been investigated by UL in accordance with the Standard(s) indicated on this Certificate.

**Standard(s) for Safety:** UL 508C Power Conversion Equipment  
CAN/CSA C22.2 No. 274-17- Adjustable speed drives.  
**Additional Information:** See the UL Online Certifications Directory at <https://iq.ulprospector.com> for additional information.

This *Certificate of Compliance* does not provide authorization to apply the UL Mark. Only the UL Follow-Up Services Procedure provides authorization to apply the UL Mark.

Only those products bearing the UL Mark should be considered as being UL Certified and covered under UL's Follow-Up Services.

Look for the UL Certification Mark on the product.



Bruce Mahrenholz, Director North American Certification Program  
UL LLC

Any information and documentation involving UL Mark services are provided on behalf of UL LLC (UL) or any authorized licensee of UL. For questions, please contact a local UL Customer Service Representative at <http://ul.com/aboutul/locations/>



### 17.3 EU Declaration of Conformity CE Marking

NTI AG / LinMot<sup>®</sup>

Bodenaeckerstrasse 2

8957 Spreitenbach

Switzerland

Tel.: +41 (0)56 419 91 91

Fax: +41 (0)56 419 91 92

declares under sole responsibility the compliance of the products:

- Drives of the Series **C1250-MI-XC-xS-xxx**

with the EMC Directive 2014/30/EU.

Applied harmonized standards:

- **EN 61800-3:2004 + A1:2012**
- **EN 61800-3:2018**

According to the EMC directive, the listed devices are not independently operable products.

Compliance of the directive requires the correct installation of the product, the observance of specific installation guides and product documentation. This was tested on specific system configurations.

The safety instructions of the manuals are to be considered.

The product must be mounted and used in strict accordance with the installation instructions contained within the installation guide, a copy of which may be obtained from NTI AG.

Company: NTI AG

Spreitenbach, 04.08.2022



-----  
Dr. Ronald Rohner / CEO NTI AG

## 17.4 UK Declaration of Conformity UKCA Marking

NTI AG / LinMot®

Bodenaeckerstrasse 2

8957 Spreitenbach

Switzerland

Tel.: +41 (0)56 419 91 91

Fax: +41 (0)56 419 91 92

declares under sole responsibility the compliance of the products:

- Drives of the Series **C1250-MI-XC-xS-xxx**

with the EMC Regulation S.I. 2016 No. 1091.

Applied designated standards:

- EN 61800-3:2004 + A1:2012
- EN 61800-3:2018

According to the EMC regulation, the listed devices are not independently operable products.

Compliance of the regulation requires the correct installation of the product, the observance of specific installation guides and product documentation. This was tested on specific system configurations.

The safety instructions of the manuals are to be considered.

The product must be mounted and used in strict accordance with the installation instructions contained within the installation guide, a copy of which may be obtained from NTI AG.

Company: NTI AG

Spreitenbach, 23.03.2022



-----  
Dr. Ronald Rohner / CEO NTI AG

# ALL LINEAR MOTION FROM A SINGLE SOURCE

## Europe / Asia Headquarters

**NTI AG - LinMot & MagSpring**  
Bodenaeckerstrasse 2  
CH-8957 Spreitenbach  
Switzerland

Sales / Administration: +41 56 419 91 91  
[office@linmot.com](mailto:office@linmot.com)

Technical Support: +41 56 544 71 00  
[support@linmot.com](mailto:support@linmot.com)

Web: <https://www.linmot.com>

## North / South America Headquarters

**LinMot USA Inc.**  
N1922 State Road 120, Unit 1  
Lake Geneva, WI 53147  
USA

Sales / Administration: 262.743.2555  
[usasales@linmot.com](mailto:usasales@linmot.com)

Technical Support: 262.743.2555  
[usasupport@linmot.com](mailto:usasupport@linmot.com)

Web: <https://www.linmot-usa.com>

Visit <https://linmot.com/contact/> to find a distributor near you.