

External Position Sensor

MS01-1/D-SSI

Non-contacting measuring position sensors, using magnets with integrated processing electronics for servo drives series C and E. The absolute position value can be read from an upstream control unit with a resolution of 5mm via encoder interface. In addition, an incremental interface with quadrature signals in various resolutions is available as an option.

Together with the MB01-1000-ABS magnetic band, the MS01/D-SSI position sensor is part of a high-resolution, robust, linear measurement system.



Features:

- » Max. resolution::
5 µm absolute, 1 µm incremental
- » Repeatability 0.005 mm
- » Output circuit SSI, RS485 (absolute), LD (incremental)
- » Reading distance/Strip max. 1.3 mm
- » Max. measuring length 10.24 m
- » Status-LEDs for Diagnosis
- » IP67 protection class, not sensitive to dust, moisture, or dirt

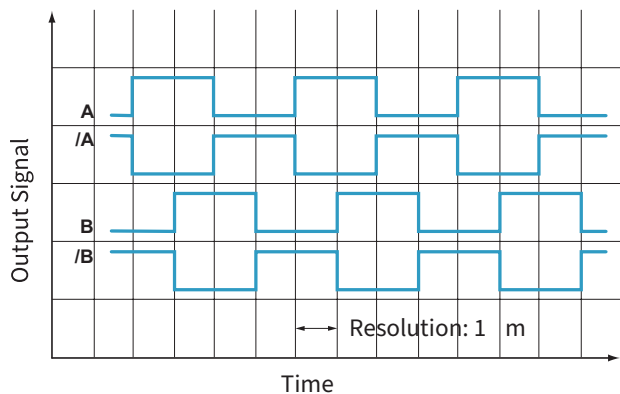

STRIP LENGTH AND COUNTING DIRECTION

required strip length =
Measuring length + 80mm (min. 90 mm)

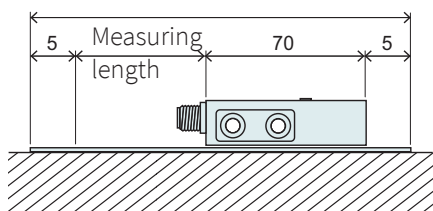

← Direction of travel

Print on strip Print on Sensor

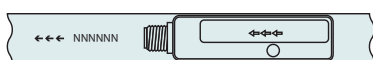

INSTALLATION

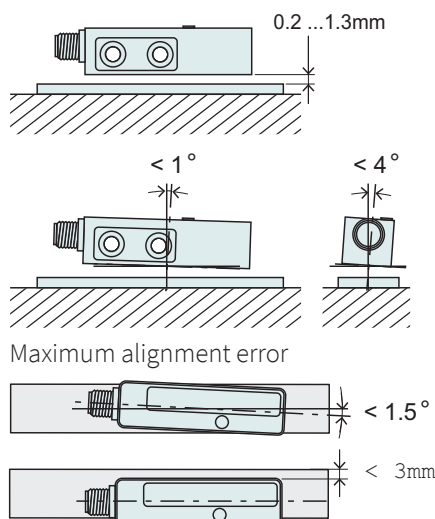

MINIMUM DISTANCE FROM SLIDER

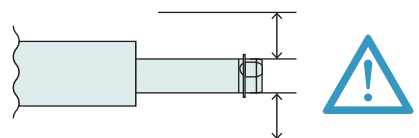

In order to rule out influence of the magnetic LinMot slider on the position measurement, the following minimal distances to the magnetic strip should be observed:

Linear Motor:	Minimum distance:
P01-23...	30 mm
P01-37...	40 mm
P01-48...	60 mm
P10-54...	60 mm
P10-70...	50 mm

DIMENSIONS

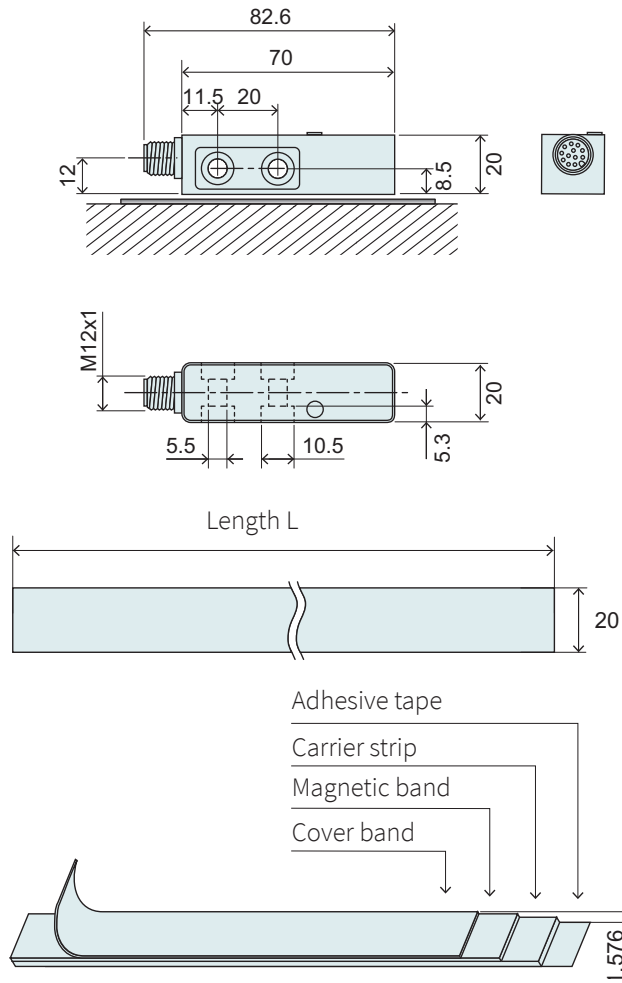

Connector wiring

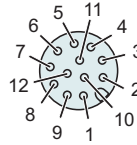

Pin	Connector wiring	Wire color Connection cable KSS01-12.../ABS- ENC-10
1	nc	grey-pink
2	D+	pink
3	D-	grey
4	T-	black
5	+UB	white
6	/A	green
7	A	yellow
8	/B	blue
9	B	red
10	Config	red-blue
	GND	The sensor is in the SSI mode.
	+UB (while encoder supply is being turned on)	The sensor is in the boot loader mode for the first 10s (installing new firmware is enabled), then it changes over to the service mode.
		Setting of the position value to the calibration value (only if the sensor is in the SSI mode)
11	T+	purple
12	OV	brown

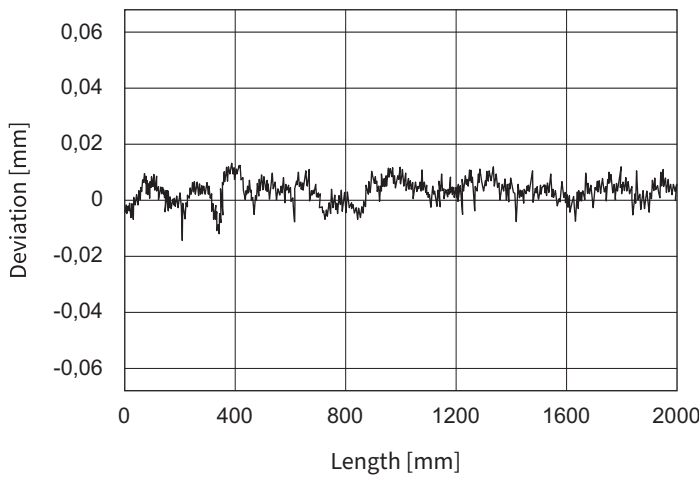

Technical data magnetic band	
Order length	Measuring length +80 mm
Width	20 mm
Carrier material	Spring steel band
Precision class	± 50 µm at 20°C
Temperature coefficient	(11 ± 1) × 10 ⁻⁶ / °K
Storage temperature range	-20...70°C
Storage temperature range	-40...70°C
Protection class	IP 67
Mounting	Self adhesive magnetic band

ORDERING INFORMATION

Item	Description	Item-No.
MS01-1/D-SSI	Linear Encoder 1 µm, A/B (for absolute strip)	0150-2095
MB01-1000-ABS	Magnetic absolute strip, 1 mm Pitch, per cm	0150-2096
EC01-ABS/ENC-12-S	MS01-1/D-SSI Encoder connector straight	0150-3616
Special cable KSS01-12-D15/ABS-ENC-	for MS01-1/D-SSI on C1100/C1200/C1400/E1200/E1400 Drives	0150-3652
KSS05-02/08-.../ABS-ENC-10	for MS01-1/D-SSI, 10m, flying leads	0160-3387