

Installation Guide

ENG

Connectors and Extension Cables

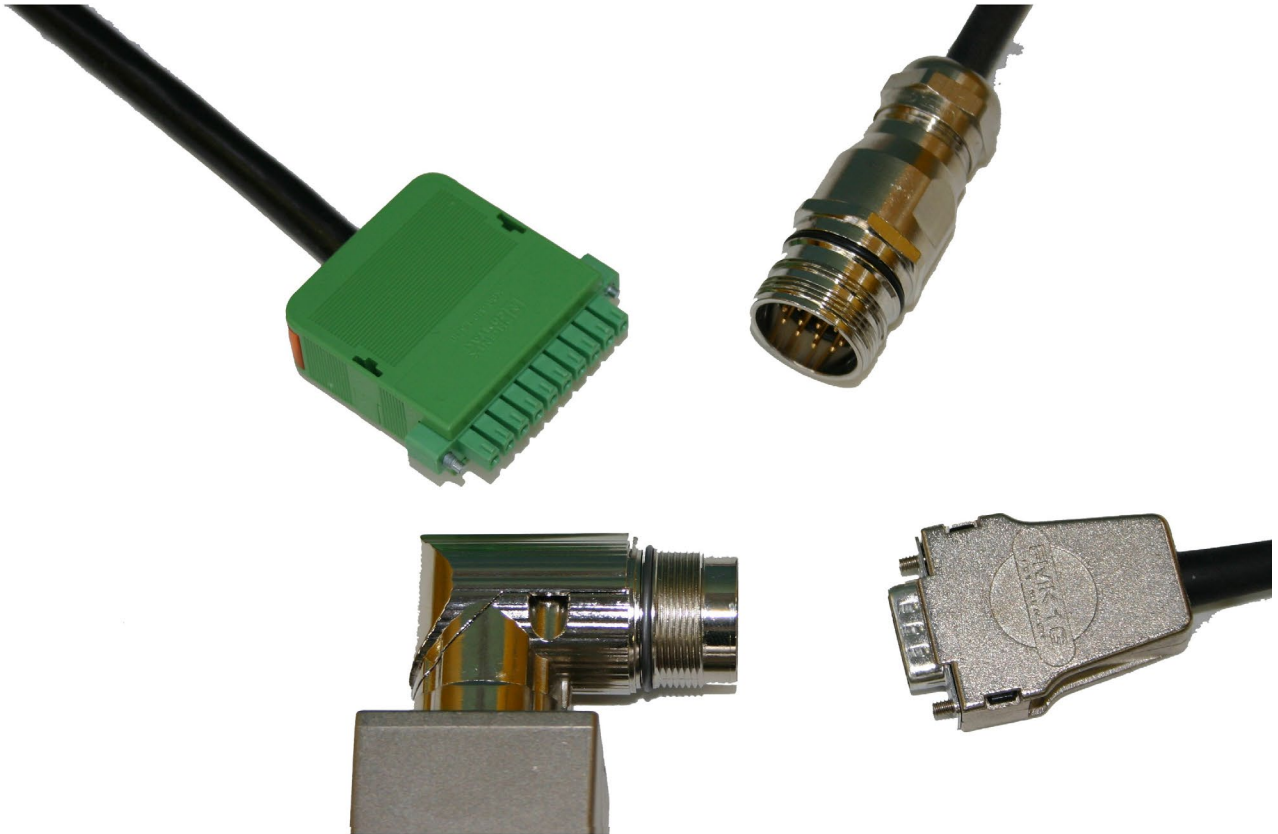

Content

1	Caution	3
2	Definition of extension cables	4
3	Technical data and pin-out of extension cables	5
4	Recommended cables for linear motors	7
5	Connector types	8
6	Water tight shrink tube MCP01-18 for IP67 connections	13
7	Connectors and cables attached directly to the LinMot stators	14
8	Assembling guide for C-Connectors “male”	15
9	Assembling guide for C-Connectors “female”	16
10	Assembling guide for R-Connectors (male)	17
11	Assembling guide for R-Connectors (female)	18
12	Ordering Information	19
12.1	Ordering information for cables per meter.....	19
12.2	Ordering information for connectors	19
12.3	Ordering information for custom length cables.....	20
13	Ordering information for extension and adapter cables (from stock)	21

1 Caution



Do not connect or disconnect motor when there is power on the servo drive. Switch the signal and the power voltage of the servo drive off!



Connecting the flat cable to the PS01-23Sx80 stator may most probably lead to shorts and damage motor and servo drive if done under power! Switch the Signal and the power voltage of the servo drive off!



Wrong connections can damage servo drive and destroy stator!



Double-check each connection!



Check ('Hypot') self-made extension cables with high voltage (1500Vdc)



Do not wrap motor cables attached to the stators over end of stator. Maintain minimum bending radius.



The motor cable attached to the stator is NOT a high flex / trailing chain cable. For moving stator applications please use special LinMot KS.. high flex / trailing chain extension cables.



LinMot KS.. high flex / trailing chain cables and also other high flex / trailing chain cables must be replaced in scheduled maintenance process in many applications.



LinMot KS.. high flex / trailing chain cables may be rolled at minimum specified radius and are NOT intended to be 'Twisted'.

2 Definition of extension cables

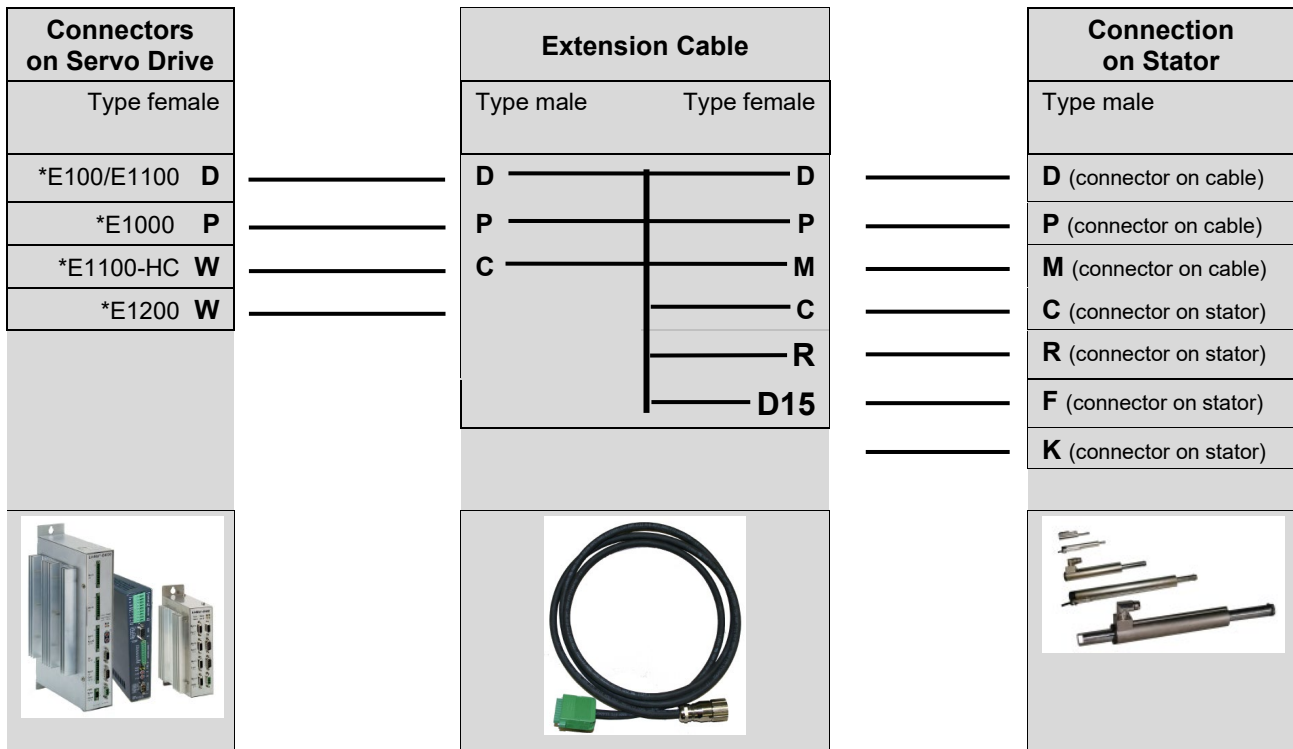

* Servo Drive Series

K 15 – D / C – 4 – NTI

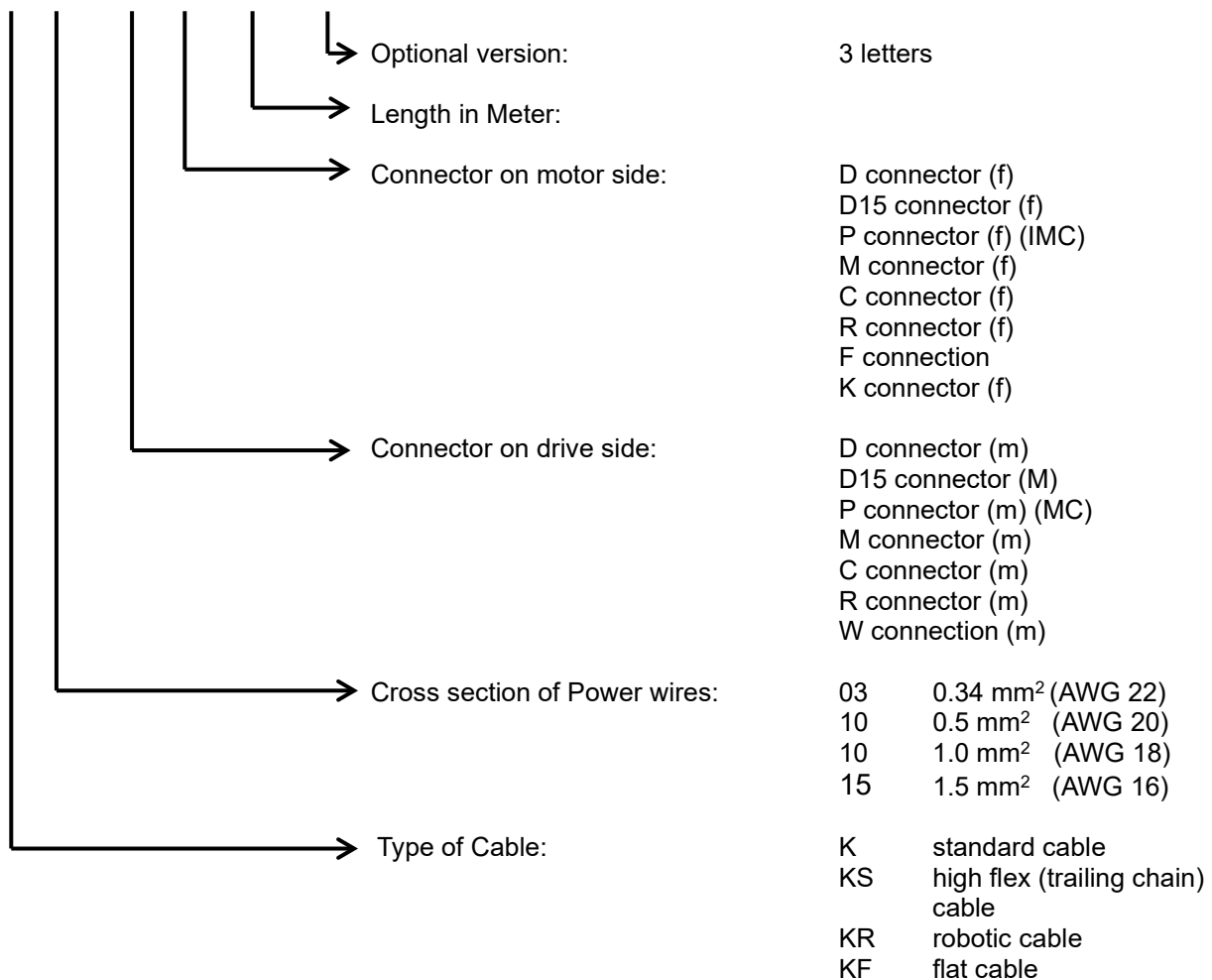

3 Technical data and pin-out of extension cables

All LinMot extension cables (except KS03) use same construction. Wire gauges and connector pin numbers may vary.

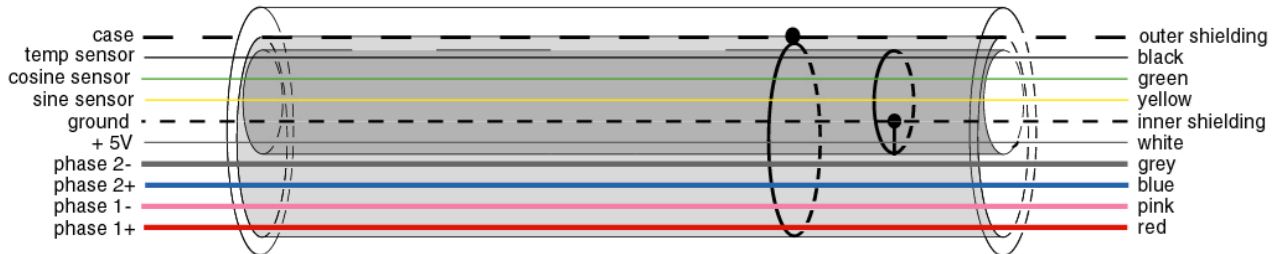

Cable Color (general)	Cable Color KS03	Assignment
red	red	Phase1+
pink	pink	Phase1-
blue	blue	Phase2+
grey	grey	Phase2-
white	white	+5V
Inner shield*	brown	GROUND*
yellow	yellow	Sensor Sine
green	green	Sensor Cosine
black	black	Temp. sensor
shield	shield	CASE / SHIELD



*Do not connect Inner and Outer Shield of the Extension Cable together. Inner Shield is used as Ground!

	Standard Motor Cable		Trailing Chain Cable			Robot Cable		
Cable type	K05-04/05	K15-04/05	KS03-09	KS05-04/05	KS10-04/05	KR03-09	KR05-04/05	KR10-04/05
Wire cross-section Motor phases	0.5 mm ² (AWG20)	1.5 mm ² (AWG16)	0.34 mm ² (AWG22)	0.5 mm ² (AWG20)	1.0 mm ² (AWG18)	0.34 mm ² (AWG22)	0.5 mm ² (AWG20)	1.0 mm ² (AWG18)
Wire cross-section Sensor signal	0.14 mm ² (AWG26)		0.14 mm ² (AWG26)			0.14 mm ² (AWG26)		
Material Wire insulation	TPE-U		TPE-E			TPE-E		
Material Cable sheath	PUR		PUR			PUR		
Colour Cable sheath	black		black			black		
Cable cross section	8.2 mm (0.31 in)	11.2 mm (0.44 in)	6.7 mm (0.26 in)	9.5 mm (0.38 in)	10.8 mm (0.42 in)	7.4 mm (0.29 in)	9.7 mm (0.38 in)	10.9 mm (0.43 in)
Weight	83 kg/km (295 lb/mi)	180 kg/km (639 lb/mi)	64 kg/km (227 lb/mi)	113 kg/km (401 lb/mi)	139 kg/km (493 lb/mi)	69 kg/km	109 kg/km (387 lb/mi)	136 kg/km (493 lb/mi)
Approvals	(-)	UL / CSA 300V E467697	UL / CSA 300V E172204			UL / CSA 300V E172204		
AWM-Style	(-)	20233	21198	20235	20235	21198	20233	20233
Minimum bending radius static	25 mm (1 in)	50 mm (2 in)	25 mm (1 in)	30 mm (1.2 in)	50 mm (2 in)	30 mm (1.2 in)	40 mm (1.6 in)	50 mm (2 in)
Minimum bending radius moving	Not suitable for applications With moving motor cable		50 mm (2 in)	60 mm (2.4 in) no torsion	100 mm (4 in) no torsion	60 mm (2.4 in) Max. Torsion: ±180° pro 0.5 m*	80 mm (3.2 in) Max. Torsion: ±270° per 0.5 m (19.7 in)	100 mm (4 in) Max. Torsion: ±270° per 0.5 m (19.7 in)
Temperature range	-40°...+80°C		-40°...+80°C			-40°...+80°C		

* ±270° / 0.5 m permitted for initialization.

4 Recommended cables for linear motors

Minimum Strand Diameter						
	Max. Cont. Force [A rms]		Strand diameter according to DIN		Strand diameter according to UL	
	Passive cooling	Fan cooling	Passive cooling	Fan cooling	Passive cooling	Fan cooling
PS01-23x80	0.6	1.1	K(x)05	K(x)05	K(x)05	K(x)05
PS01-23x80F-HP	1.2	1.0	K(x)05	K(x)05	K(x)05	K(x)05
PS02-23Sx80	0.6	1.0	K(x)05	K(x)05	K(x)05	K(x)05
PS02-23Sx80F-HP	1.1	2.0	K(x)05***	K(x)05***	K(x)05***	K(x)05***
PS01-23x160	0.6	1.0	K(x)05	K(x)05	K(x)05	K(x)05
PS01-23x160F	0.8	1.6	K(x)05	K(x)05	K(x)05	K(x)05
PS01-23x160H-HP	1.8	2.7	K(x)05	K(x)05	K(x)05	K(x)05
PS01-37Sx60-HP	0.9	1.8	K(x)05	K(x)05	K(x)05	K(x)05
PS01-37x120	1.5	1.9	K(x)05	K(x)05	K(x)05	K(x)05
PS01-37x120F-HP	2.1	3.8	K(x)05	K(x)05	K(x)05	K(x)05
PS01-37Sx120F-HP	1.5	3.0	K(x)05	K(x)05	K(x)05	K(x)05
PS01-37x240	1.0	1.8	K(x)05	K(x)05	K(x)05	K(x)05
PS01-37x240F	1.5	2.8	K(x)05	K(x)05	K(x)05	K(x)05
PS01-48x240	2.7	4.7	K(x)05	K(x)05	K(x)05	K(x)10
PS01-48x240F	4.8	8.3	K(x)05	K(x)05	K(x)10	K(x)15
PS01-48x360F	4.6	7.9	K(x)05	K(x)05	K(x)10	K(x)15
P04-37x120F-HP	2.9	4.0	K(x)05	K(x)05	K(x)05	K(x)05
P04-48x240F	4.7	8.3	K(x)05	K(x)05	K(x)10	K(x)15
PS01-37x120F-HP-SSC	1.3	3.4	K(x)05	K(x)05	K(x)05	K(x)05
PS01-48x240F-SSC	3.3	9.2	K(x)05	K(x)05	K(x)05	K(x)15*
PS01-48x360F-SSC	3.4	9.4	K(x)05	K(x)05	K(x)05	K(x)15**

*Up to max. cont. force 230 N rms

**Up to max. cont. force 333 N rms

*** K(x)03: up to 6m length

5 Connector types

C-Connector

C-Connector male or female			Pin	Assignment	Wire color
			A	Phase1+	red
			B	Phase1-	pink
			C	Phase2+	blue
			D	Phase2-	grey
			E	+5V	white
			F	GROUND*	Inner shield
			G	Sensor Sine	yellow
Description	Part-No		H	Sensor Cosine	green
MC01-C/m	0150-3093	Male	L	Temp. sensor	black
MC01-C/f	0150-3080	Female	Case	SHIELD	Outer shield
C/m-connector assembled	0150-3099	Male			
C/f-connector assembled	0150-3146	Female			



D-Connector

D-Sub 9 pole male or female			Pin	Assignment	Wire color
			1	Phase1+	red
			6	Phase1-	pink
			2	Phase2+	blue
			7	Phase2-	grey
			3	+5V	white
			8	GROUND*	Inner shield
			4	Sensor Sine	yellow
Description	Part-No		9	Sensor Cosine	green
MC01-D/m	0150-3024	Male	5	Temp. sensor	black
MC01-D/f	0150-3025	Female	case	SHIELD	Outer shield
D/m-connector assembled	0150-3055	Male			
D/f-connector assembled	0150-3142	Female			

D15-Connector

D-Sub 15 pole male or female			Pin	Assignment	Wire color
			7&15	Phase1+	red
			3&10	Phase1-	pink
			6&14	Phase2+	blue
			2&9	Phase2-	grey
			11	+5V	white
			12	GROUND*	Inner shield
			13	Sensor Sine	yellow
Description	Part-No		5	Sensor Cosine	green
MC01-D15/m	0150-3024	Male	4	Temp. sensor	black
MC01-D15/f	0150-3025	Female	case	SHIELD	Outer shield
D15/f-connector assembled	0150-3073	Female			

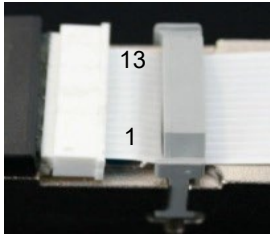
F-Connection

F-Connection			Pin	Assignment	Wire No
			1&2	Phase2-	1&2
			10&11	Phase2+	10&11
			3&4	Phase1-	3&4
			12&13	Phase1+	12&13
			9	Sensor Sine	9
			7	GROUND*	7
			5	+5V	5
Description	Part-No		6	Temp. sensor	6
ZIF-Line, 13 pin, pitch 1.25 mm	0160-1580	For print mounting	8	Sensor Cosine	8
			No shield	SHIELD	
 Connecting the flat cable will most probably lead to shorts and damage motor and servo drive if done under power!					

K-Connection

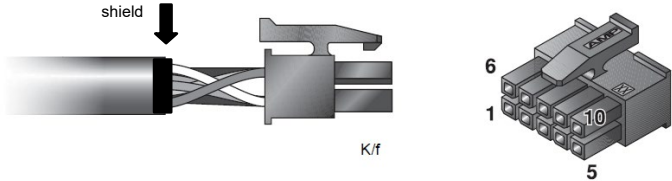
K-Connection female			Pin	Assignment *	Wire color
			1	Phase1+	red
			2	Phase2+	blue
			3	NC	NC
			4	Phase1-	pink
			5	Phase2-	grey
			6	Sensor Sine	yellow
			7	Sensor Cosine	green
			8	GROUND*	brown
			9	+5V	white
			10	Temp. sensor	black
			Motorcase	SHIELD	shield
Description	Part-No				
MC01-K/f	0150-3345	Female			
K/f connector assembled	0150-3346	Female			

N-Connector

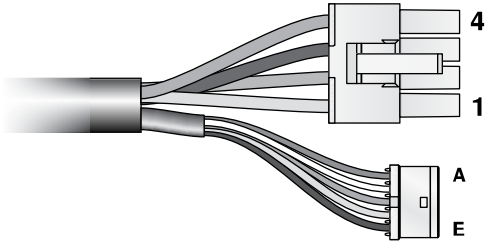
N-Connector female			Pin	Assignment	Wire color
			4	Phase1+	red
			3	Phase1-	pink
			2	Phase2+	blue
			1	Phase2-	grey
			A	+5V	white
			B	GROUND*	Inner shield
			C	Sensor Sine	yellow
			D	Sensor Cosine	green
			E	Temp. sensor	black
Description	Part-No				
MC01-N/f	0150-3407	Female			
N/f connector assembled	0150-3408	Female			

M-Connector

M-Connector male or female			Pin	Assignment	Wire color
			1	Phase1+	red
			2	Phase1-	pink
			3	Phase2+	blue
			4	Phase2-	grey
			5	+5V	white
			6	GROUND*	Inner shield
			7	Sensor Sine	yellow
Description	Part-No		8	Sensor Cosine	green
MC01-M/m	0150-3047	Male	9	Temp. sensor	black
MC01-M/f	0150-3046	Female	Case	SHIELD	Outer shield
M/m-connector assembled	0150-3057	Male			
M/f-connector assembled	0150-3145	Female			

P-Connector

P-Connector male or female			Pin	Assignment	Wire color
			1	Phase1+	red
			2	Phase1-	pink
			3	Phase2+	blue
			4	Phase2-	grey
			5	+5V	white
			6	GROUND*	Inner shield
			7	Sensor Sine	yellow
Description	Part-No		8	Sensor Cosine	green
MC01-P/m	0150-3020	Male (MC)	9	Temp. sensor	black
MC01-P/f	0150-3021	Female (IMC)	10	SHIELD	Outer shield
P/m-connector assembled	0150-3056	Male (MC)			
P/f-connector assembled	0150-3144	Female (IMC)			

R-Connector

R-Connector male or female			Pin	Assignment	Wire color
			1	Phase1+	red
			2	Phase1-	pink
			3	Phase2+	blue
			4 (-)	Phase2-	grey
			A	+5V	white
			B	GROUND*	Inner shield
			C	Sensor Sine	yellow
Description	Part-No		D	Sensor Cosine	green
MC01-R/m	0150-3130	Male	E	Temp. sensor	black
MC01-R/f	0150-3129	Female	Case	SHIELD	Outer shield
R/m-connector assembled	0150-3097	Male			
R/f-connector assembled	0150-3143	Female			

W-Connection

W-Connection			Pin	Assignment	Wire color
			Red wire	Phase1+	red
			Pink wire	Phase1-	pink
			Blue wire	Phase2+	blue
			Grey wire	Phase2-	grey
			3	+5V	white
			8	GROUND*	Inner Shield
			4	Sensor Sine	yellow
Description	Part-No		9	Sensor Cosine	green
MC01-W/m	0150-3140	Kit with Dsub 9 pole male, special shrink tube, ...	5	Temp. sensor	black
W/m-connector assembled	0150-3147	Male	Shield	SHIELD	Outer shield

Note: connection consists of a 9 pole Dsub for Sensor Signals and 5 separate wires (power and shield)

Y-Connection

Y-Connection for all cables (ex. KS03)			Pin	Assignment	Wire color									
			1	Phase1+	red									
			2	Phase1-	pink									
			3	Phase2+	blue									
			4	Phase2-	grey									
			5	SHIELD	Outer shield									
			Dsub, 9 pol			3	+5V	white						
						8	GROUND*	Inner Shield						
						4	Sensor Sine	yellow						
						9	Sensor Cosine	green						
						5	Temp. sensor	black						
<table border="1"> <thead> <tr> <th>Description</th> <th>Part-No</th> <th></th> </tr> </thead> <tbody> <tr> <td>MC01-Y/m</td> <td>0150-3498</td> <td>Kit with Dsub 9 pole male, Phoenix MSTB2.5 HC, ferrite special shrink tube, ...</td> </tr> <tr> <td>Y/m-connector assembled</td> <td>0150-3499</td> <td>Male</td> </tr> </tbody> </table>			Description	Part-No		MC01-Y/m	0150-3498	Kit with Dsub 9 pole male, Phoenix MSTB2.5 HC, ferrite special shrink tube, ...	Y/m-connector assembled	0150-3499	Male	Case	SHIELD	Outer shield
Description	Part-No													
MC01-Y/m	0150-3498	Kit with Dsub 9 pole male, Phoenix MSTB2.5 HC, ferrite special shrink tube, ...												
Y/m-connector assembled	0150-3499	Male												

Note: Connection consists of a 9 pole Dsub for Sensor Signals and shield and a Phoenix connector for power and shield.

Y-Fe-Connection

Y-Fe-Connection for cable KS03			Pin	Assignment	Wire color		
			1	Phase1+	red		
			2	Phase1-	pink		
			3	Phase2+	blue		
			Ferrite over 4 power wires		4	Phase2-	grey
					5	SHIELD	Shield
			Dsub, 9 pol		3	+5V	white
					8	GROUND*	brown
					4	Sensor Sine	yellow
					9	Sensor Cosine	green
		5	Temp. sensor	black			
		Case	SHIELD	Shield			
Description	Part-No						
MC01-Y-Fe/m	0150-3289	Kit with Dsub 9 pole male, Phoenix MSTB2.5 HC, ferrite special shrink tube, ...					
Y/m-connector assembled	0150-3499	Male					
<p>Note: 1) Connection consists of a 9 pole Dsub for Sensor Signals and shield and a Phoenix connector for power and shield. 2) Maximal cable length for KS03: 6 m</p>							

6 Water tight shrink tube MCP01-18 for IP67 connections



The special shrink tube MCP01-18 is a heat shrink tube with heat activated sealant which is used to increase the resistant to water infiltration.



Material: Polyolefin

Part-No: 0150-3089

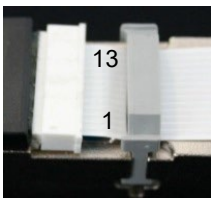
7 Connectors and cables attached directly to the LinMot stators

Connector Type	D-Sub 9 pole		Flat cable	D-Sub 15 pole ZIF-Line AMP, pitch 1.25 mm		Phoenix Connector	
Stators	<i>PS01-23x80</i> <i>PS01-23x160</i>		<i>PS02-23Sx80</i>	<i>Adapter cable to flat cable for</i> <i>PS02-23Sx80</i>		<i>PS01-37x120</i> <i>PS01-37x240</i>	
	PIN	Wire	PIN & Wire	PIN	Wire	PIN	Wire
Phase1+	1	red	12&13	7&15	red	1	red
Phase1-	6	pink	3&4	3&10	pink	2	pink
Phase2+	2	blue	10&11	6&14	blue	3	blue
Phase2-	7	grey	1&2	2&9	grey	4	grey
+5V	3	white	5	11	white	5	white
GROUND	8	brown*	7	12	Inner shield	6	Brown*
Sensor Sine	4	yellow	9	13	yellow	7	yellow
Sensor Cosine	9	green	8	5	green	8	green
Temp. Sensor	5	black	6	4	black	9	black
SHIELD* of stator and stator cable	Case	shield	No shield	Case	Outer shield	10	Inner & outer shield
Connector on the stators (-cables)				Pin 1 and 8 not connected			

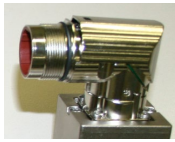
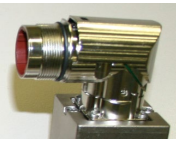
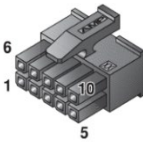
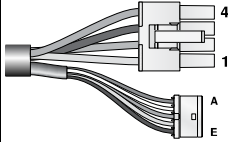
Connector Type	M-Connector		C-Connector	R-Connector	K-Connector		N-Connector	
Stators	<i>PS01-23x..-M</i> <i>PS01-37x..-M</i>		<i>PS01-37x120-C</i> <i>PS01-37x240-C</i> <i>PS01-48x240-C</i>	<i>PS01-23x80-R</i> <i>PS01-23x160-R</i>	<i>PS02-23Sx80F-HP</i>		<i>PS01-37Sx60F-HP-N</i> <i>PS01-37Sx120F-HP-N</i>	
	PIN	Wire	PIN	PIN	PIN	Wire	PIN	Wire
Phase1+	1	red	A	1	1	red	4	red
Phase1-	2	pink	B	2	4	pink	3	pink
Phase2+	3	blue	C	3	2	blue	2	blue
Phase2-	4	grey	D	4 (-)	5	grey	1	grey
+5V	5	white	E	A	9	white	A	white
GROUND	6	brown*	F	B	8	brown	B	Inner shield
Sensor Sine	7	yellow	G	C	6	yellow	C	yellow
Sensor Cosine	8	green	H	D	7	green	D	green
Temp. Sensor	9	black	L	E	10	black	E	black
SHIELD* of stator and stator cable	Case	Inner & outer shield	Case	Case	Case	shield	Case	Outer shield
Connector on the stators (-cables)								



*** Note :** Above table shows Motor cables or connectors, which are attached directly to the stators. Extension Cables are double shielded and may be wired different to the motor cables! See chapter Extension Cables. The two shields of the Extension Cables must not be connected together: The inner shield of the Extension Cables is used as GROUND and must be connected to GROUND*, only the outer shield may be connected to SHIELD* of the connectors.



- Do not connect or disconnect motor when there is power on the servo drive.
- Double-check each connection! Wrong connections can destroy servo drive and stator.

8 Assembling guide for C-Connectors “male”



	a[mm²]	Positioner	Colour
Signal	0,14 - 1,0	C0.003.00	blue
Power	0,35 - 2,5	C0.004.00	blue

M = 10 - 17 Nm

9 Assembling guide for C-Connectors “female”

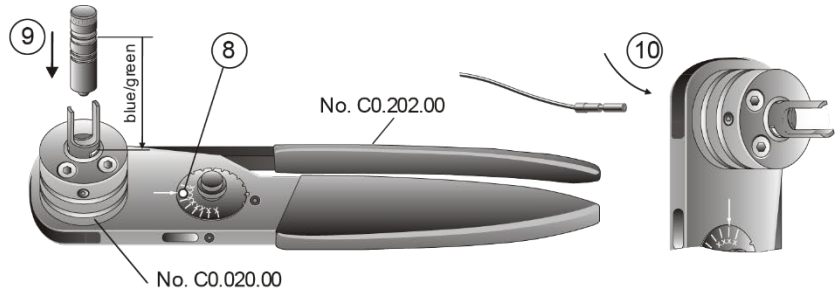
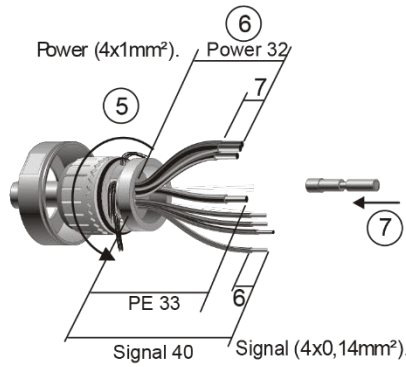
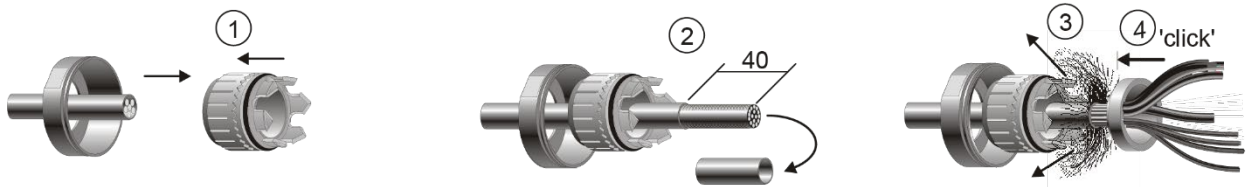
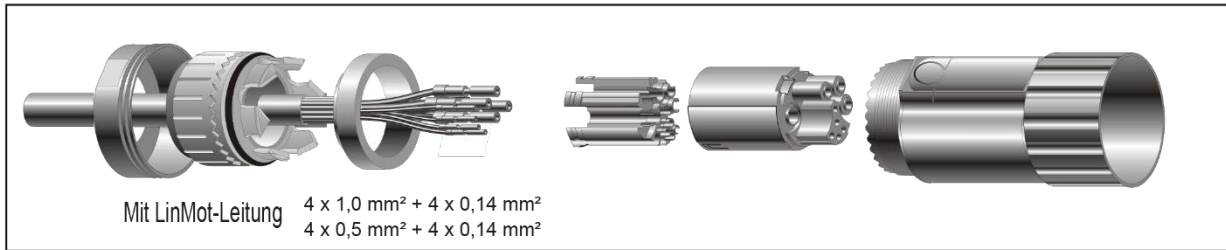

	a [mm ²]	crimping tool		posit ionierer	
		No.	crimp setting	No.	colour
Signal	0,14	C0.20100	1	C0.003.00	green
Power	0,5	C0.20100	5	C0.004.00	blue
	1,0	C0.20100	6	C0.004.00	blue

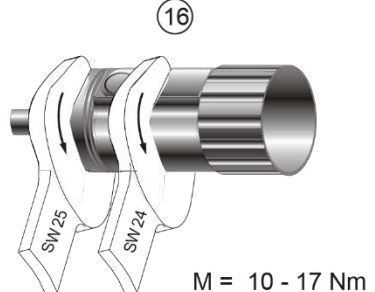
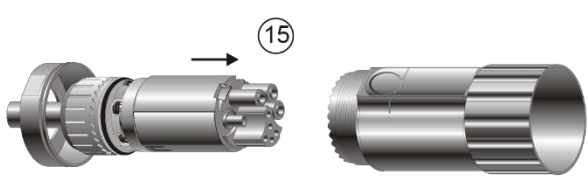
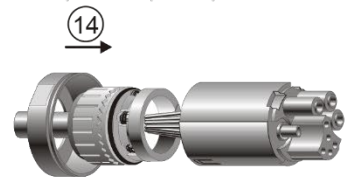
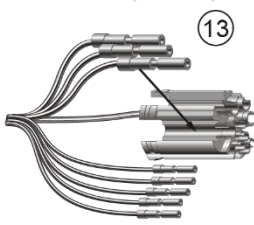
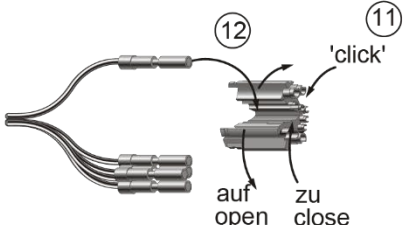

10 Assembling guide for R-Connectors (male)

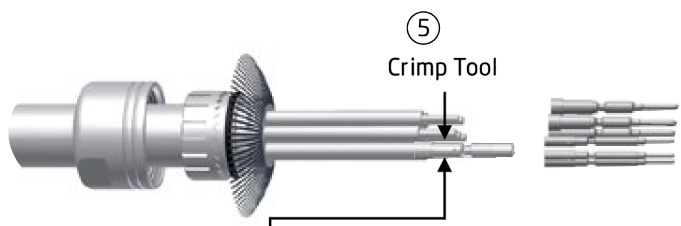
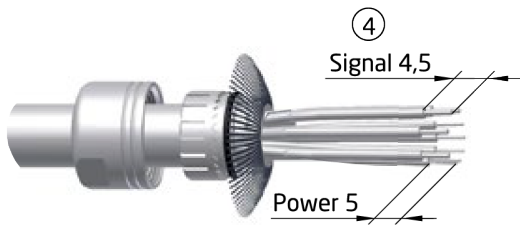
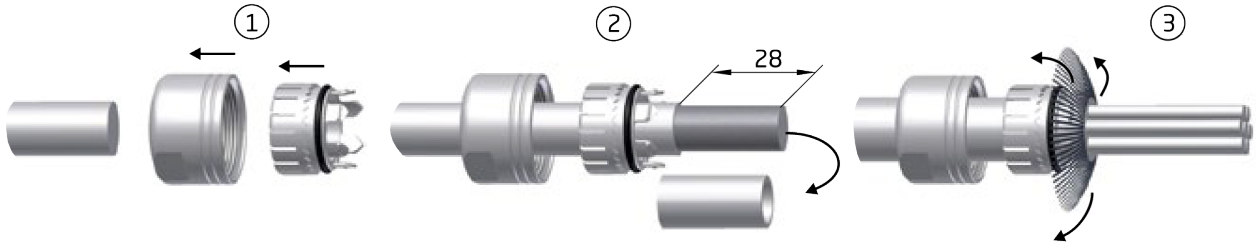
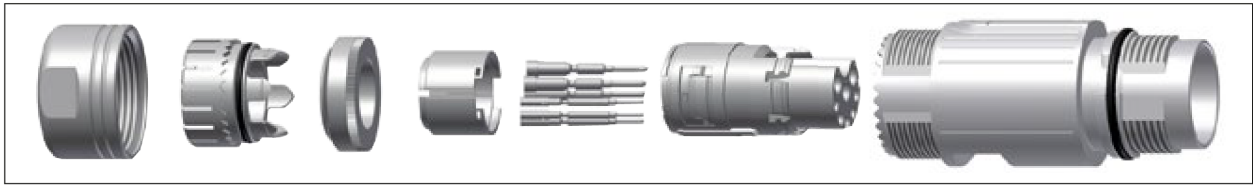

Crimpzange/ Crimp Tool	Einstellungen/ Tool Settings
C0.201.00	siehe Bedienungs- anleitung für Crimpzange / see crimp tool manual
C0.235.00 (optional)	

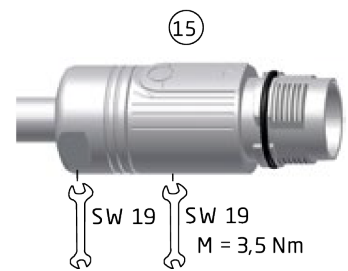
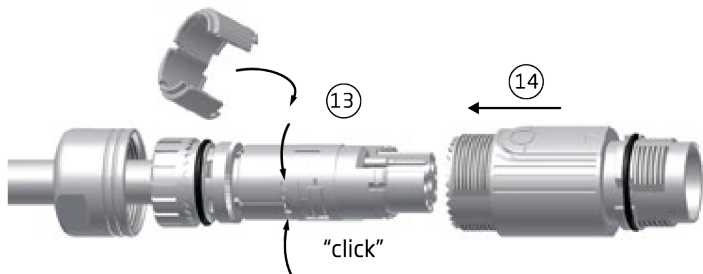
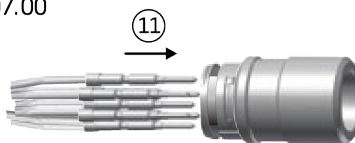
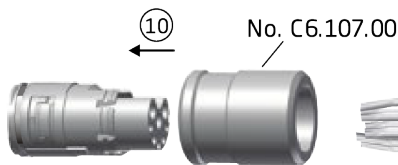
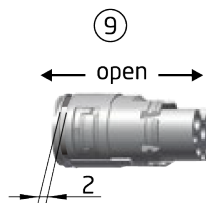
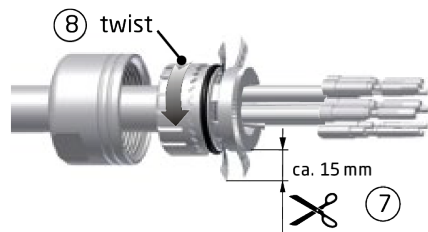
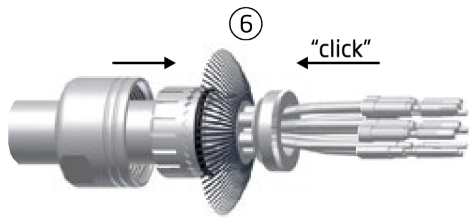

11 Assembling guide for R-Connectors (female)

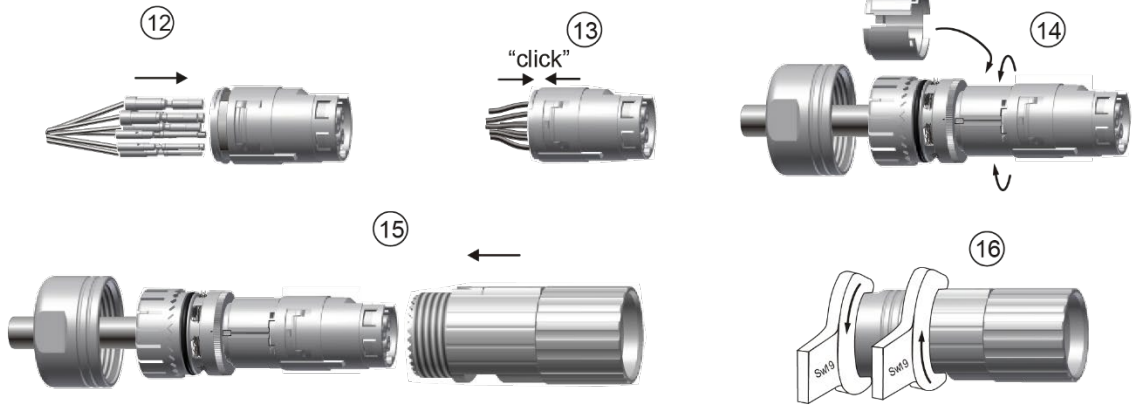
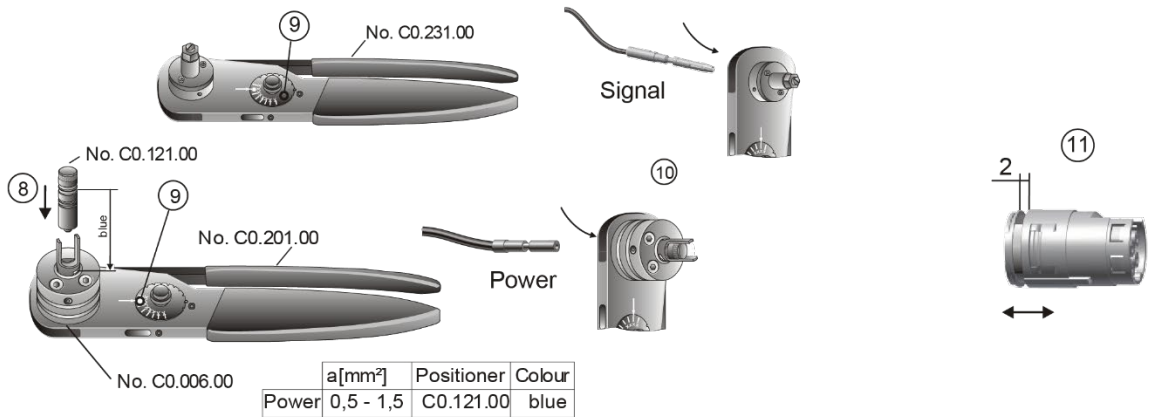
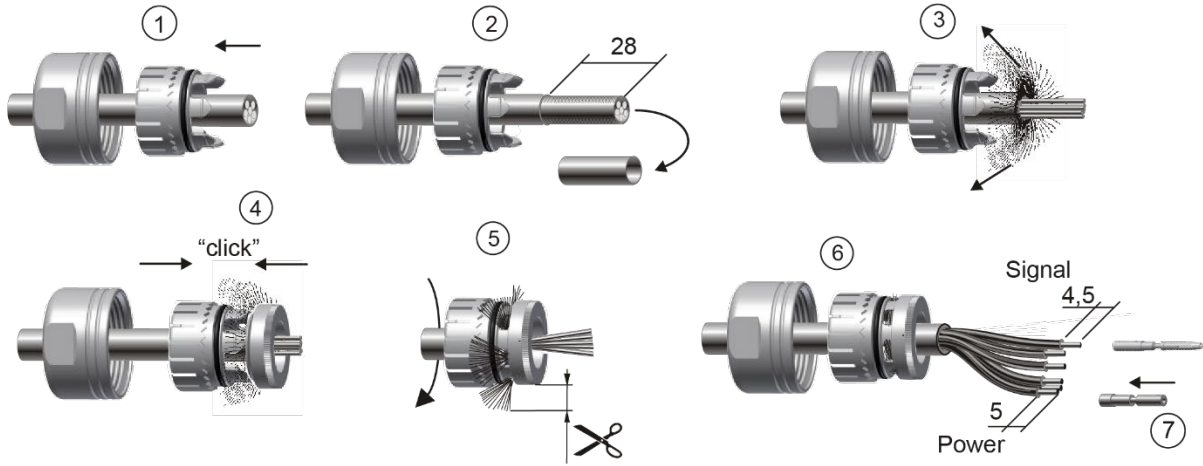
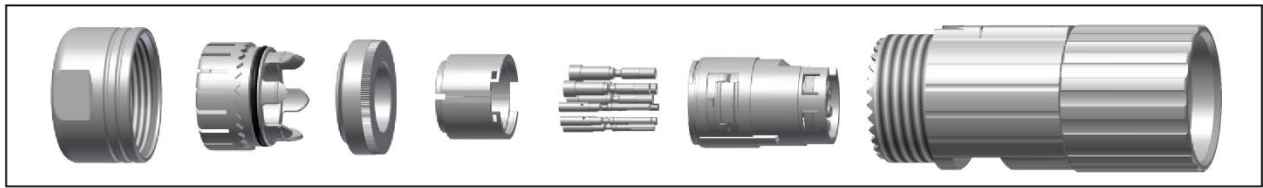

M= 3,5 Nm

12 Ordering Information

12.1 Ordering information for cables per meter

Description	Old description	Part- No	Note
K05-04/05	K01-04/05	0150-1920	0.5 mm ² standard cable per meter
K05-04/05-50	K01-04/05-50	0150-1956	0.5 mm ² standard cable on 50 m roll
K05-04/05-100	K01-04/05-100	0150-1957	0.5 mm ² standard cable on 100 m roll
K05-04/05-200	K01-04/05-200	0150-1958	0.5 mm ² standard cable on 200 m roll
K15-04/05		0150-1978	1.5 mm ² standard cable per meter
K15-04/05 -100		0150-1969	1.5 mm ² standard cable on 100 m roll
KS03-09		0150-2182	0.34 mm ² standard cable per meter
KS05-04/05	KS02-04/05	0150-1938	0.5 mm ² trailing chain cable per meter
KS05-04/05-100	KS02-04/05-100	0150-1959	0.5 mm ² trailing chain cable on 100 m roll
KS10-04/05		0150-1977	1.0 mm ² trailing chain cable per meter
KS10-04/05-100		0150-1968	1.0 mm ² trailing chain cable on 100 m roll
KR10-04/05		0150-1830	1.0 mm ² robotic cable per meter
KR10-04/05-100		0150-1831	1.0 mm ² robotic cable on 100 m roll

12.2 Ordering information for connectors

Type		Description	Old Description	Part-No	Note
C	Male	MC01-C/m		0150-3093	
	Female	MC01-C/f		0150-3080	
D	Male	MC01-D/m	MC01-23/E	0150-3024	
	Female	MC01-D/f	MC01-23/P	0150-3025	
D15	Male	MC01-D15/m		0150-3135	
	Female	MC01-D15/f		0150-3136	
M	Male	MC01-M/m		0150-3047	
	Female	MC01-M/f		0150-3046	Cable Ø ≤ 10 mm
		MC01-M/f/12		0150-3102	Cable Ø 10-12 mm / 1mm ² max
P	Male	MC01-P/m	MC01-37/E	0150-3020	
	Female	MC01-P/f	MC01-37/P	0150-3021	
R	Male	MC01-R/m		0150-3130	
	Female	MC01-R/f		0150-3129	
W	Male	MC01-W/m		0150-3140	Kit (connector, shrink tube ..)
K	Female	MC01-K/f		0150-3345	

12.3 Ordering information for custom length cables

K 15 – D / C – 4

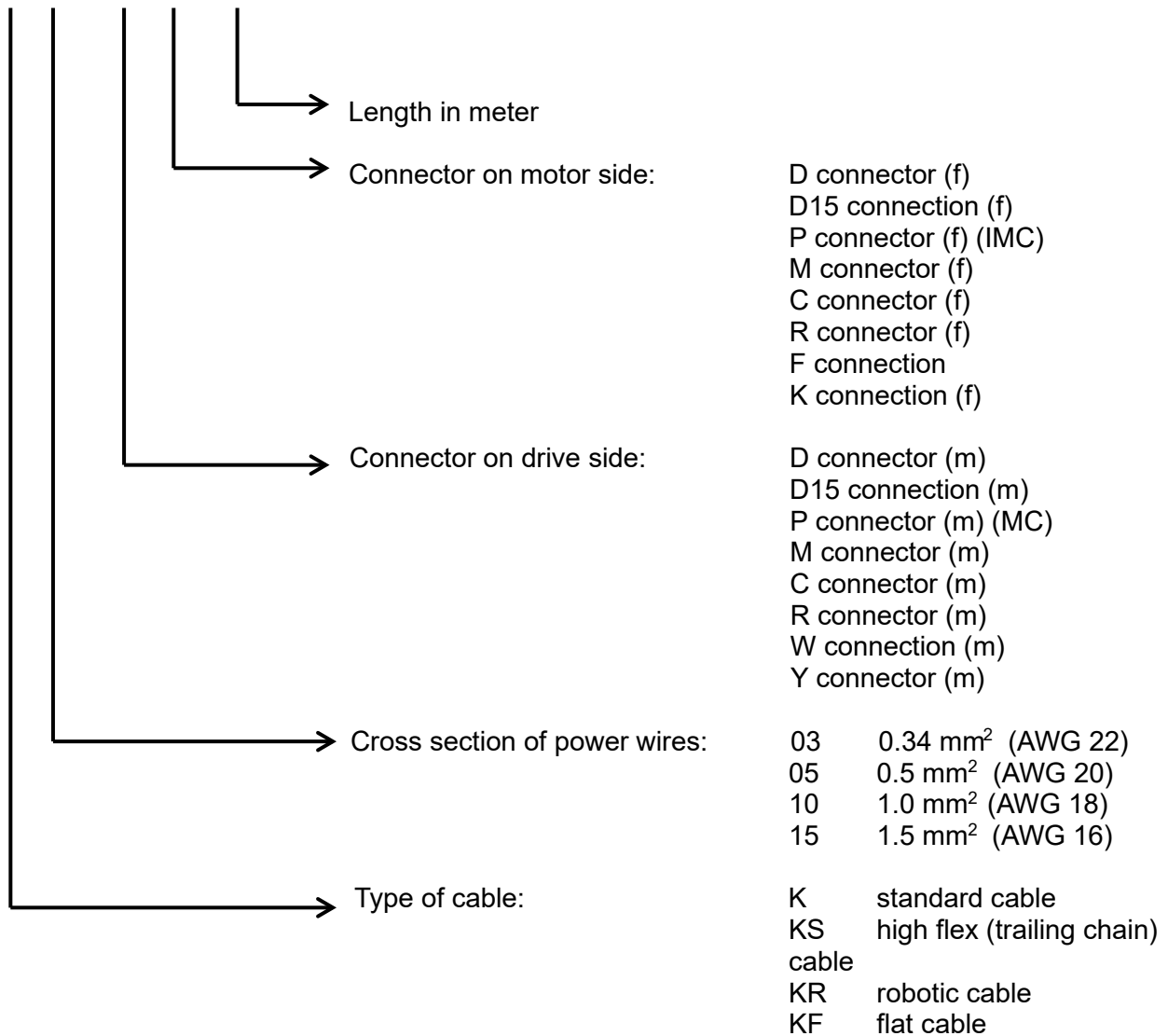

Description	Part- No	Note
MC01-C/m-as	0150-3099	C/m-connector assembled
MC01-C/f-as	0150-3146	C/f-connector assembled
MC01-D/m-as	0150-3055	D/m-connector assembled
MC01-D/f-as	0150-3142	D/f-connector assembled
MC01-D15/m-as	0150-3148	D15/m-connector assembled
MC01-D15/f-as	0150-3073	D15/f-connector assembled
MC01-M/m-as	0150-3057	M/m-connector assembled
MC01-M/f-as	0150-3145	M/f-connector assembled
MC01-P/m-as	0150-3056	P/m-connector assembled
MC01-P/f-as	0150-3144	P/f-connector assembled
MC01-R/m-as	0150-3097	R/m-connector assembled
MC01-R/f-as	0150-3143	R/f-connector assembled
MC01-W/m-as	0150-3147	W/m-connector assembled
MC01-K/f-as	0150-3346	K/f-connector assembled

Example for price calculation (details see price list) :

K 15 – D / C – 4	1 pc	MC01-D/m-as	D/m-connector (m) assembled
	1 pc	MC01-C/f-as	C/f-connector (f) assembled
	4 m	K15-04/05	cable per Meter

13 Ordering information for extension and adapter cables (from stock)**How to find a cable:**

1. select cable Type (K (standard), KS (trailing chain) , KR (robotic cable), F (flat cable) (e.g. KS...))
2. select wire size (03, 05, 10, 15 mm²) (e.g. KS05....)
3. select connector type drive side (e.g. KS05-P....)
4. select connector type motor side (e.g. KS05-P/M...)
5. select cable length in meter (1 m = 39.37 in) description of selected cable (e.g. KS05-P/M-2)

Article number	Description		Old description
0150-1920	K05-04/05	extension cable per m	old description: K01-04/05
0150-1957	K05-04/05-100	extension cable 100m roll	old description: K01-04/05-100
0150-1958	K05-04/05-200	extension cable 200m roll	old description: K01-04/05-200
0150-1956	K05-04/05-50	extension cable 50m roll	old description: K01-04/05-50
0150-1819	K05-D/C-2	extension cable D/C, 2 m	old description: K01-D/C-2
0150-1820	K05-D/C-4	extension cable D/C, 4 m	
0150-1821	K05-D/C-6	extension cable D/C, 6 m	
0150-1822	K05-D/C-8	extension cable D/C, 8 m	
0150-1910	K05-D/D-2	extension cable D/D, 2 m	old description: K01-23/02
0150-1936	K05-D/D15-1	adapter cable D/D15, 1m (for PS01-23Sx80)	old description: AC01-100/23-S
0150-1911	K05-D/D-4	extension cable D/D, 4 m	old description: K01-23/04
0150-1912	K05-D/D-6	extension cable D/D, 6 m	old description: K01-23/06
0150-1913	K05-D/D-8	extension cable D/D, 8 m	old description: K01-23/08
0150-1921	K05-D/P-0.25	adapter cable D/P, 0.25m	old description: AC01-100/37
0150-1949	K05-D/P-2	extension cable D/P, 2 m	old description: AC01-100/37-200
0150-1995	K05-D/P-4	extension cable D/P, 4 m	old description: AC01-100/37-400
0150-1994	K05-D/P-6	extension cable D/P, 6 m	old description: AC01-100/37-600
0150-1832	K05-D/R-2	extension cable D/R, 2 m	
0150-1833	K05-D/R-4	extension cable D/R, 4 m	
0150-1834	K05-D/R-6	extension cable D/R, 6 m	
0150-1835	K05-D/R-8	extension cable D/R, 8 m	
0150-1818	K05-P/C-2	extension cable P/C, 2 m	
0150-1804	K05-P/C-4	extension cable P/C, 4 m	
0150-1805	K05-P/C-6	extension cable P/C, 6 m	
0150-1806	K05-P/C-8	extension cable P/C, 8 m	
0150-1922	K05-P/D-0.4	adapter cable P/D, 0.4 m	old description: AC01-1000/23
0150-1915	K05-P/P-2	extension cable P/P, 2 m	old description: K01-37/02
0150-1916	K05-P/P-4	extension cable P/P, 4 m	old description: K01-37/04
0150-1917	K05-P/P-6	extension cable P/P, 6 m	old description: K01-37/06

0150-1918	K05-P/P-8	extension cable P/P, 8 m	old description: K01-37/08
0150-1947	K05-W/D-0.4	adapter cable W/D, 0.4 m	old description: AC01-1100/23
0150-1825	K05-W/M-4	extension cable W/M, 4 m	
0150-1948	K05-W/P-0.4	adapter cable W/P, 0.4 m	old description: AC01-1100/37
0150-2119	K05-W/R-2	extension cable W/C, 2 m	
0150-2120	K05-W/R-4	extension cable W/C, 4 m	
0150-2121	K05-W/R-6	extension cable W/C, 6 m	
0150-2122	K05-W/R-8	extension cable W/C, 8 m	
0150-2132	K05-W/R-10	extension cable W/C, 10 m	
0150-2425	K05-Y/C-2	extension cable Y/C, 2 m	
0150-2426	K05-Y/C-4	extension cable Y/C, 4 m	
0150-2427	K05-Y/C-6	extension cable Y/C, 6 m	
0150-2428	K05-Y/C-8	extension cable Y/C, 8 m	
0150-2421	K05-Y/R-2	extension cable Y/R, 2 m	
0150-2422	K05-Y/R-4	extension cable Y/R, 4 m	
0150-2423	K05-Y/R-6	extension cable Y/R, 6 m	
0150-2424	K05-Y/R-8	extension cable Y/R, 8 m	
0150-1978	K15-04/05	extension cable per m	
0150-1969	K15-04/05-100	extension cable, 100 m roll	
0150-1811	K15-W/C-2	extension cable W/C, 2 m	
0150-1801	K15-W/C-4	extension cable W/C, 4 m	
0150-1802	K15-W/C-6	extension cable W/C, 6 m	
0150-1803	K15-W/C-8	extension cable W/C, 8 m	
0150-2429	K15-Y/C-2	extension cable Y/C, 2 m	
0150-2430	K15-Y/C-4	extension cable Y/C, 4 m	
0150-2431	K15-Y/C-6	extension cable Y/C, 6 m	
0150-2432	K15-Y/C-8	extension cable Y/C, 8 m	
0150-2150	KF02-D15/F-0.08	flat cable 0.08m, for PS02-23Sx80-F	
0150-2156	KF02-D15/F-0.16	flat cable 0.16m, for PS02-23Sx80-F	
0150-2152	KF02-D15/F-0.32	flat cable 0.32m, for PS02-23Sx80-F	
0150-2154	KF02-D15/F-0.48	flat cable 0.48m, for PS02-23Sx80-F	
0150-2158	KF02-D15/F-0.70	flat cable 0.70m, for PS02-23Sx80-F	
0150-1830	KR10-04/05	robotic cable (per m)	
0150-1831	KR10-04/05-100	robotic cable, 100m roll	
0150-2182	KS03-09	trailing chain cable (per m)	max. cable length: 6m
0150-2187	KS03-W/K-2	trailing chain cable W/K, 2m	
0150-2185	KS03-R/K-1	trailing chain cable R/K, 1m	
0150-2186	KS03-R/K-2	trailing chain cable R/K, 2m	
0150-2446	KS03-y-Fe/K-2	trailing chain cable Y-Fe/K, 2m	
0150-2447	KS03-y-Fe/K-4	trailing chain cable Y-Fe/K, 4m	

0150-2448	KS03-y-Fe/K-6	trailing chain cable Y-Fe/K, 6m	
0150-1959	KS05-04/05-100	trailing chain cable 100 m roll	
0150-1938	KS05-04/05	trailing chain cable (per m)	old description: KS02-04/05
0150-1827	KS05-C/C-2	trailing chain cable C/C, 2m	
0150-1828	KS05-C/C-4	trailing chain cable C/C, 4 m	
0150-1823	KS05-D/C-4	trailing chain cable D/C, 4 m	
0150-1824	KS05-D/C-8	trailing chain cable D/C, 8 m	
0150-1988	KS05-D/D-2	trailing chain cable D/D, 2 m	old description:KS02-23/02
0150-1989	KS05-D/D-4	trailing chain cable D/D, 4 m	old description: KS02-23/04
0150-1980	KS05-D/M-2	trailing chain cable D/M, 2 m	old description: : KS01-D/M-02
0150-1981	KS05-D/M-4	trailing chain cable D/M, 4 m	old description: KS01-D/M-04
0150-1812	KS05-D/M-6	trailing chain cable D/M, 6 m	old description: KS01-D/M-06
0150-1813	KS05-D/M-8	trailing chain cable D/M, 8 m	old description: KS01-D/M-08
0150-1836	KS05-D/R-4	trailing chain cable D/R, 4 m	
0150-1837	KS05-D/R-8	trailing chain cable D/R, 8 m	
0150-1809	KS05-P/C-4	trailing chain cable P/C, 4 m	
0150-1810	KS05-P/C-8	trailing chain cable P/C, 8 m	
0150-1982	KS05-P/M-2	trailing chain cable P/M, 2 m	old description: KS01-P/M-02
0150-1983	KS05-P/M-4	trailing chain cable P/M, 4 m	old description: KS01-P/M-04
0150-1814	KS05-P/M-6	trailing chain cable P/M, 6 m	old description: KS01-P/M-06
0150-1815	KS05-P/M-8	trailing chain cable P/M, 8 m	old description: KS01-P/M-08
0150-1990	KS05-P/P-2	trailing chain cable P/P, 2 m	old description: KS02-37/02
0150-1991	KS05-P/P-4	trailing chain cable P/P, 4 m	old description: KS02-37/04
0150-2436	KS05-Y/C-4	trailing chain cable Y/C, 4 m	
0150-2437	KS05-Y/C-6	trailing chain cable Y/C, 6 m	
0150-2438	KS05-Y/C-8	trailing chain cable Y/C, 8 m	
0150-2442	KS05-Y/N-2	trailing chain cable Y/N, 2 m	
0150-2443	KS05-Y/N-4	trailing chain cable Y/N, 4 m	
0150-2444	KS05-Y/R-6	trailing chain cable Y/N, 6 m	
0150-2445	KS05-Y/R-8	trailing chain cable Y/N, 8 m	
0150-2433	KS05-Y/R-4	trailing chain cable Y/R, 4 m	
0150-2434	KS05-Y/R-6	trailing chain cable Y/R, 6 m	
0150-2435	KS05-Y/R-8	trailing chain cable Y/R, 8 m	
0150-1977	KS10-04/05	trailing chain cable per m	
0150-1968	KS10-04/05-100	trailing chain cable, 100m roll	
0150-1816	KS10-C/C-2	trailing chain cable C/C, 2 m	
0150-1817	KS10-C/C-4	trailing chain cable C/C, 4 m	
0150-1807	KS10-W/C-4	trailing chain cable W/C, 4 m	
0150-1808	KS10-W/C-8	trailing chain cable W/C, 8 m	
0150-2439	KS10-Y/C-4	trailing chain cable Y/C, 4 m	
0150-2440	KS10-Y/C-6	trailing chain cable Y/C, 6 m	
0150-2441	KS10-Y/C-8	trailing chain cable Y/C, 8 m	

ALL LINEAR MOTION FROM A SINGLE SOURCE

LinMot Europe

NTI AG - LinMot & MagSpring

Bodenaeckerstrasse 2
CH-8957 Spreitenbach

Sales / Administration: +41-(0)56-419 91 91
office@linmot.com

Tech. Support: +41-(0)56-544 71 00
support@linmot.com

Tech. Support (Skype): skype:support.linmot

Fax: +41-(0)56-419 91 92
Web: <http://www.linmot.com/>

LinMot USA

LinMot USA, Inc.

N1922 State Road 120, Unit 1
Lake Geneva, WI 53147

Sales / Administration : 262-743-2555

Tech. Support: usasupport@linmot.com

E-Mail: usasales@linmot.com
Web: <http://www.linmot-usa.com/>

Visit <http://www.linmot.com/> to find a distributor next to you.