

F1150-DS-UC-3S**Important Notice:**

Please note that we use machine translation to provide documents in your local language. It is possible that not all texts will be translated correctly. If you have any questions or discrepancies regarding the accuracy of the information in the translated version, please read the original English version ([0185-1102-E](#)).

Please visit <http://www.linmot.com> to check for the latest version of this document!

Content

1	General Information	3
1.1	Introduction	3
1.2	Explanation of Symbols	3
1.3	Qualified Personnel	3
1.4	Liability	3
1.5	Copyright	3
2	Safety Instructions	4
3	System Overview	6
4	Interfaces	7
5	Functionality	8
6	Software	8
7	Power Supply and Grounding	9
8	Description of the connectors / Interfaces	10
8.1	Protective Earth	10
8.2	X1	10
8.3	X2/X3 Motor-Connection	11
8.4	X4	12
8.5	X13	12
8.6	X17 – X18	13
8.7	X79	13
8.8	X15	13
8.9	S1 – S2	13
8.10	S14 Reset Button	13
8.11	System LEDs	14
8.12	RT Bus LEDs	14
9	System LED Blink Codes	14
10	Safety Wiring	15
11	Physical Dimension	16
12	Power Supply Requirements	17
12.1	Motor-Power Supply	17
12.2	Signal-Power Supply	17
13	Regeneration	17
14	Ordering Information	18
14.1	Drives	18
14.2	Accessories	18
15	International Certifications	18
15.1	EU Declaration of Conformity CE Marking	19
15.2	UK Declaration of Conformity UKCA Marking	20
16	Version history	21
17	Contact information	22

1 General Information

1.1 Introduction

This manual includes instructions for the assembly, installation, maintenance, transport, and storage of the servo drives. The document is intended for electricians, mechanics, service technicians, and warehouse staff. Read this manual before using the product and always observe the general safety instructions and those in the relevant section. Keep these operating instructions in an accessible place and make them available to the personnel assigned.

1.2 Explanation of Symbols



Triangular warning signs warn of danger.



Round command symbols tell what to do.

1.3 Qualified Personnel

All work such as installation, commissioning, operation, and service of the product may only be carried out by qualified personnel. The personnel must have the necessary qualifications for the corresponding activity and be familiar with the installation, commissioning, operation, and service of the product. The manual and in particular the safety instructions must be carefully read, understood, and observed.

1.4 Liability

NTI AG (as manufacturer of LinMot and MagSpring products) excludes all liability for damages and expenses caused by incorrect use of the products. This also applies to false applications, which are caused by NTI AG's own data and notes, for example during sales, support or application activities. It is the responsibility of the user to check the data and information provided by NTI AG for correct applicability in terms of safety. In addition, the entire responsibility for safety-related product functionality lies exclusively with the user. Product warranties are void if products are used with stators, sliders, servo drives, or cables not manufactured by NTI AG unless such use was specifically approved by NTI AG.

NTI AG's warranty is limited to repair or replacement as stated in our standard warranty policy as described in our "terms and conditions" previously supplied to the purchaser of our equipment (please request a copy of same if not otherwise available). Further reference is made to our general terms and conditions.

1.5 Copyright

This work is protected by copyright.

Under the copyright laws, this publication may not be reproduced or transmitted in any form, electronic or mechanical, including photocopying, recording, microfilm, storing in an information retrieval system, not even for training purposes, or translating, in whole or in part, without the prior written consent of NTI AG.

LinMot® and MagSpring® are registered trademarks of NTI AG.

2 Safety Instructions



For your personal safety

Disregarding the following safety measures can lead to severe injury to persons and damage to material:

- Only use the product as directed.
- Never commission the product in the event of visible damage.
- Never commission the product before assembly has been completed.
- Do not carry out any technical changes on the product.
- Only use the accessories approved for the product.
- Only use original spare parts from LinMot.
- Observe all regulations for the prevention of accidents, directives and laws applicable on site.
- Transport, installation, commissioning, and maintenance work must only be carried out by qualified personnel.
- Observe IEC 364 and CENELEC HD 384 or DIN VDE 0100 and IEC report 664 or DIN VDE 0110 and all national regulations for the prevention of accidents.
- According to the basic safety information, qualified, skilled personnel are persons who are familiar with the assembly, installation, commissioning, and operation of the product and who have the qualifications necessary for their occupation.
- Observe all specifications in this documentation.
- This is the condition for safe and trouble-free operation and the achievement of the specified product features.
- The procedural notes and circuit details described in this documentation are only proposals. It is up to the user to check whether they can be transferred to the applications. NTI AG / LinMot does not accept any liability for the suitability of the procedures and circuit proposals described.
- LinMot servo drives, and the accessory components can include live and moving parts (depending on their type of protection) during operation. Surfaces can be hot.
- Non-authorized removal of the required cover, inappropriate use, incorrect installation, or operation create the risk of severe injury to persons or damage to material assets.
- For more information, please see the documentation.
- High amounts of energy are produced in the drive. Therefore, it is required to wear personal protective equipment (body protection, headgear, eye protection, hand guard).



Application as directed

- Drives are components, which are designed for installation in electrical systems or machines. They are not to be used as domestic appliances, but only for industrial purposes according to EN 61000-3-2.
- When drives are installed into machines, commissioning (i.e., starting the operation as directed) is prohibited until it is proven that the machine complies with the regulations of the EC Directive 2006/42/EG (Machinery Directive); EN 60204 must be observed.
- Commissioning (i.e., starting of the operation as directed) is only allowed when there is compliance with the EMC Directive (2014/30/EU).
- The technical data and supply conditions can be obtained from the nameplate and the documentation. They must be strictly observed.



Transport, storage

- Please observe the notes on transport, storage, and appropriate handling.
- Observe the climatic conditions according to the technical data.

**Installation**

- The drives must be installed and cooled according to the instructions given in the corresponding documentation.
- The ambient air must not exceed the degree of pollution 2 according to EN 61800-5-1.
- Ensure proper handling and avoid excessive mechanical stress. Do not bend any components and do not change any insulation distances during transport or handling. Do not touch any electronic components and contacts.
- Drives contain electrostatic sensitive devices, which can easily be damaged by inappropriate handling. Do not damage or destroy any electrical components since this might endanger your health!

**Electrical connection**

- When working on live drives, observe the applicable national regulations for the prevention of accidents.
- The electrical installation must be carried out according to the appropriate regulations (e.g. cable cross-sections, circuit breakers, fuses, PE connection). Additional information can be obtained from the documentation.
- This product can cause high-frequency interferences in non-industrial environments, which require measures for interference suppression.

**Operation**

- If necessary, systems including drives must be equipped with additional monitoring and protection devices according to the valid safety regulations (e.g. law on technical equipment, regulations for the prevention of accidents). The drives can be adapted to your application. Please observe the corresponding information given in the documentation.
- After the drive has been disconnected from the supply voltage, all live components and power connections must not be touched immediately because capacitors can still be charged. Please observe the corresponding stickers on the drive. All protection covers and doors must be shut during operation.

**Burn Hazard**

The heat sink (housing) of the drive can have an operating temperature of $> 80\text{ }^{\circ}\text{C}$: Contact with the heat sink results in burns.

**Caution - Risk of Electric Shock!**

- Before servicing, disconnect supply, wait 5 minutes and measure between PWR+ and PGND to be sure that the capacitors have discharged below 42 VDC.
- The power terminals Ph1+, Ph1-, Ph2+, Ph2- and PWR+ remain live for at least 5 minutes after disconnecting from the power supplies.

**Grounding**

All metal parts that are exposed to contact during any user operation or servicing and likely to become energized shall be reliably connected to the means for grounding.

3 System Overview

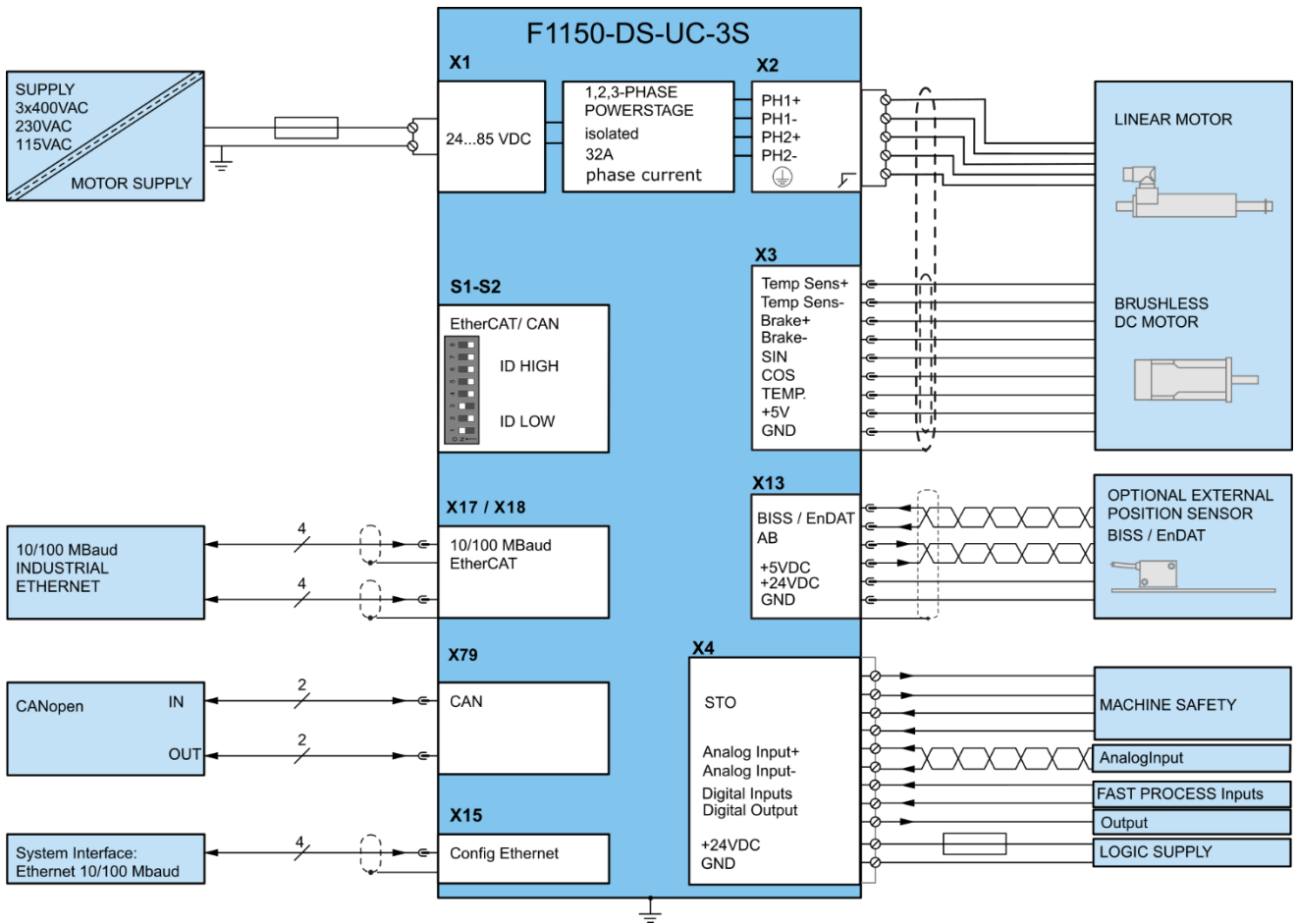

Typical servo system F1150-DS-UC-3S: Servo drive, motor, and power supply

4 Interfaces

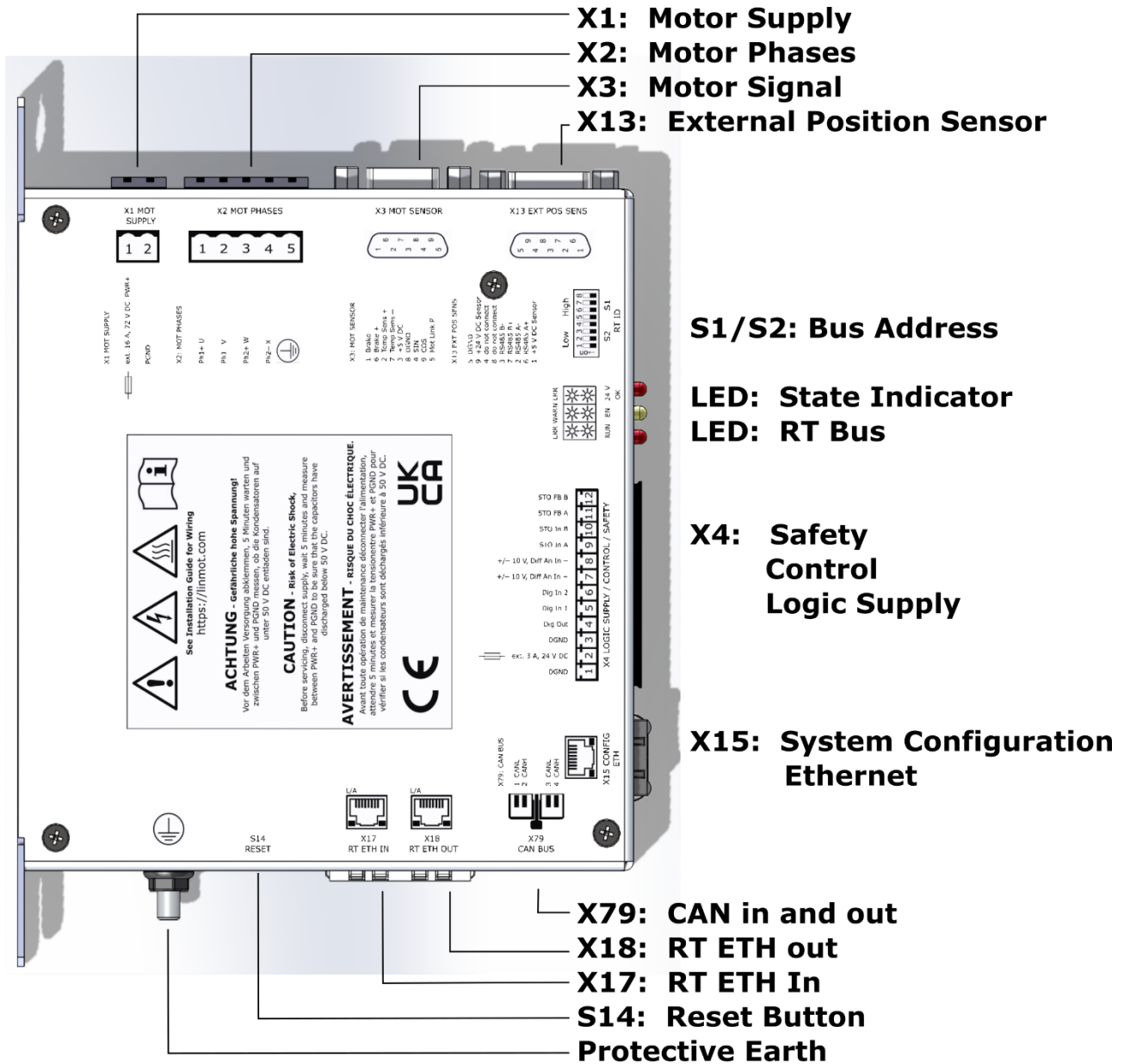

5 Functionality

	F1150-DS-UC-3S
Supply Voltage	
Motor Supply 72 VDC (24...85 VDC)	●
Logic Supply 24 VDC (22...26 VDC)	●
Motor Phase Current	
32 A peak (0-599 Hz)	●
6 A rms (preliminary rating)	●
LinMot POx- and PROx- Motors	●
Selected third party motors (contact support)	●
Plug and Play (PnP) Auto Configuration	●
Phases short-circuit on STO, disable- and error-states*	●
Command Interface	
EtherCAT CiA402 (preinstalled)	●
CANopen up to 1Mbaud (CANopen FW must be installed)	○
Programmable Motion Profiles (Curves)	
Up to 50 Motion Profiles/ Up to 8110 Curve Points	●
Programmable Command Table	
Command Table with up to 255 entries	●
External Position Sensor	
Incremental (RS422 up to 25 Mcounts/s, A-B only, Z not supp.)	●
Absolute (SSI, BiSS-B, BiSS-C, EnDat2.1, EnDat 2.2)	●
Configuration Interface	
Ethernet (X15), 100BASE-TX, IPV4 and IPV6	●
Ethernet (EoE) (only if EtherCAT is used)	●
Integrated Safety Functions	
STO Safe Torque Off (3S-Safety) with phase short-circuit	●
Control Frequencies	
PWM	16 kHz
Current controller	8 kHz
Position controller	4 kHz
Interface DS (CANopen, EtherCAT)	2 kHz

* This feature greatly improves the system behavior on the STO and error states, because the motor will be braked by the eddy current.

6 Software

The configuration software LinMot-Talk is free of charge and can be downloaded from the LinMot homepage.

7 Power Supply and Grounding

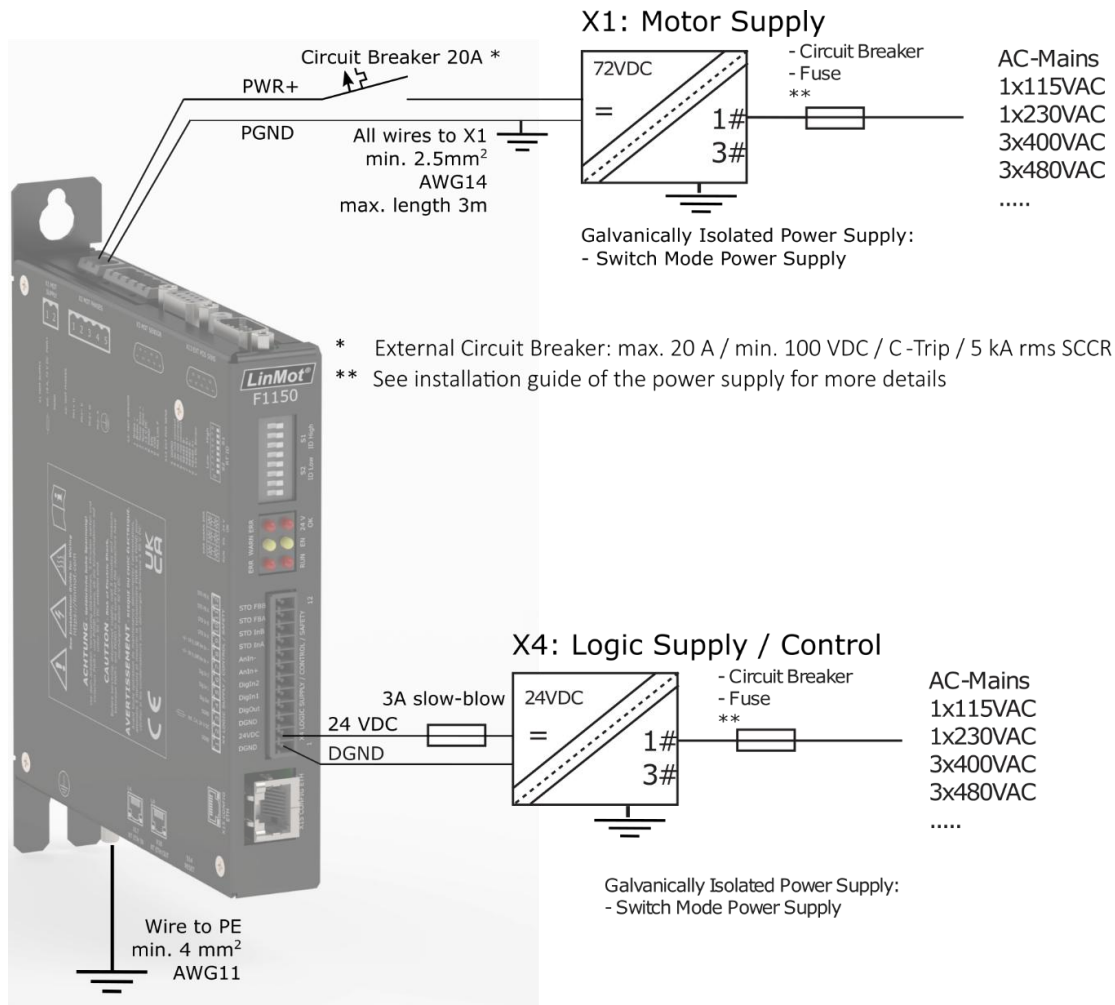

* External Circuit Breaker: max. 20 A / min. 100 VDC / C-Trip / 5 kA rms SCCR
 ** See installation guide of the power supply for more details



To assure a safe and error free operation, and to avoid severe damage to system components, **all system components must be well grounded to protective earth PE**. This includes both LinMot and all other control system components on the same ground bus.



Each system component should be tied directly to the ground bus (**star pattern**). Daisy chaining from component to component is forbidden. (LinMot motors are properly grounded through their power cables when connected to LinMot drives.)



Power supply connectors must not be connected or disconnected while DC voltage is present. Do not disconnect system components until all LinMot drive LEDs have turned off. (Capacitors in the power supply may not fully discharge for several minutes after input voltage has been disconnected). Failure to observe these precautions may result in severe damage to electronic components in LinMot motors and/or drives.



Do not switch Power Supply DC Voltage. All power supply switching, and E-Stop breaks should be done to the AC supply voltage of the power supply. Failure to observe these precautions may result in severe damage to the drive.

8 Description of the connectors / Interfaces

8.1 Protective Earth

Protective Earth	Protective Earth
	<ul style="list-style-type: none"> • Use min. 4 mm² (AWG11) • Tightening torque: 2 Nm (18 lbin)

8.2 X1

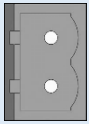
X1	Motor Supply
	<p>PWR+</p> <p>PGND</p>
	<p>Motor Supply: 72 VDC nominal (24...85 VDC) Absolute max. Rating: 72 VDC +20%. External Circuit Breaker: 20 A / min. 100 VDC / C-Trip / 5 kA rms SCCR</p> <p>PGND has to be connected to Protective Earth (near the powersupply).</p> <p>If motor supply voltage exceeds 90 VDC, the drive will go into error state.</p> <ul style="list-style-type: none"> • Use 60/75 °C copper conductors only • Conductor Cross-Section 2.5 mm² (AWG14) max Length 3 m

8.3 X2/X3 Motor-Connection

X2	Motor Phases					
	PH1+	LinMot Motor: Motor Phase	1+ Red	3-phase EC-Motor / third-party motor: Motor Phase	U	Red
	PH1-	Motor Phase	1- Pink	Motor Phase	V	Pink
	PH2+	Motor Phase	2+ Blue	Motor Phase	W	Blue
	PH2-	Motor Phase	2- Grey	Motor Phase	X	Grey
		Protective Earth		Protective Earth		
<ul style="list-style-type: none"> • Use 60/75 °C copper conductors only • Conductor cross-section: 0.5 – 2.5 mm² (depends on Motor current) / AWG 21 -14 						

X3	Motor Sensor / Brake		
	1	LinMot Motor: Do not connect	EC Motor: Brake -
	2	6 Do not connect	Brake +
	3	7 Do not connect	Temp Sens +
	4	8 +5 VDC	Temp Sens -
	5	9 DGND	+5 V DC
		Shield Mot Link P+ Shield	SIN COS Mot Link P+ Shield
DSUB-9 (f)	<p>Note:</p> <ul style="list-style-type: none"> • Use +5 VDC (X3.3) and DGND (X3.8) only for motor internal hall sensor supply (max. 100 mA). • Max. motor cable length: 50 m for LinMot Px motors. Please check the restrictions of motor, encoder and cable as well. • Brake+: 24 V / max. 500 mA, peak 1.4 A (will shut down if exceeded) the other terminal must be wired to Brake- (X3.1) <p>Caution:</p> <ul style="list-style-type: none"> • Do NOT connect DGND (X3.8) to ground or earth! <p>Temperature Sensor:</p> <ul style="list-style-type: none"> • A resistive temperature sensor (PT1000, KTY) could be connected between +5 VDC (X3.2) and KTY (X3.7) 		

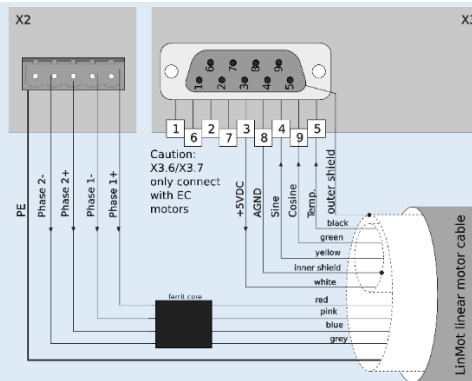

Important Notes:

Use Y-style motor cables only (for example K15-Y/C)! A W-style cable has a different shielding, so it cannot be modified to a Y-style cable!

8.4 X4

X4		Logic Supply / IO Connection			
	12	STO FB B	X4.12	STO Feedback Channel B (24VDC output, active when STO B deactivated)	
	11	STO FB A	X4.11	STO Feedback Channel A (24VDC output, active when STO A deactivated)	
	10	STO in B	X4.10	STO input Channel B (apply 24VDC to deactivate STO channel B)	
	9	STO in A	X4.9	STO input Channel A (apply 24VDC to deactivate STO channel A)	
	8	AnIn-	X4.8	Configurable differential analog Input (with X4.8)	
	7	AnIn+	X4.7	Configurable differential analog Input (with X4.7)	
	6	DigIn 2	X4.6	Configurable digital Input 2	
	5	DigIn 1	X4.5	Configurable digital Input 1	
	4	DigOut	X4.4	Configurable digital Output	
	3	DGND	X4.3	Logic Ground for Configurable digital Output	
	2	+24VDC	Power Supply	Logic Supply 22-26 VDC	
	1	DGND	Power Supply	Logic Ground	
<p>Digital inputs (X4.5 ... X4.6): 24 VDC / 5 mA (Low Level: -0.5 to 5 VDC, High Level: 15 to 30 VDC) Digital outputs (X4.4): 24 VDC / max. 100 mA, peak 1.4 A (will shut down if exceeded) The output is high side switching with integrated pull-down (1k7 to DGND) Analog inputs: 12-bit A/D converted X4.7/X4.8: +/- 10 V, input resistance 28.0 kΩ, common mode range: -5...+10 V to DGND,</p> <p>Mating connector:</p> <ul style="list-style-type: none"> • Use 60/75 °C copper conductors only • Conductor cross-section max. 1.5 mm² • Stripping length: 11.5 mm <p>Important notes: The 24 VDC logic supply for the control circuit (X4.2) must be protected with an external fuse (3 A slow blow)</p>					

8.5 X13

X13		External Position Sensor	
	5	SSI / BiSS-B / BiSS-C / EnDat2.1 / EnDat2.2 / AB	DGND
	9	+24V DC Sensor	
	4	Do not connect	
	8	Do not connect	
	3	RS485 B-	
	7	RS485 B+	
	2	RS485 A-	
	6	RS485 A+	
	1	+5V DC Sensor	
case	Shield		
DSUB-9 (m)	<p><u>Position Encoder Inputs (RS422):</u> Max. counting frequency: 25 M counts/s with quadrature decoding. A minimum of 40 ns edge separation must be guaranteed by the encoder under any circumstances! The maximal frequency of each signal is 6.25 MHz.</p> <p><u>Sensor Supply:</u> 5.15 VDC max. 300 mA 24 VDC max. 200 mA</p>		

8.6 X17 – X18

X17 – X18		RealTime Ethernet 10/100 Mbit/s
	X17 RT ETH In	Specification depends on RT Bus. Please refer to the according documentation.
	X18 RT ETH Out	
RJ-45		

8.7 X79

X79		CANopen
	1 CANL 2 CANH	CANopen in and out Termination resistor is not integrated
	3 CANL 4 CANH	
Card Edge	Edge Lock connector from Molex. Mating connector: Molex 2008900104 together with the corresponding crimp terminals (Molex 2004490001)	

8.8 X15

X15		System Config
	X15	10 / 100 Mbit/s Ethernet RJ45
	RJ-45	

8.9 S1 – S2

S1 – S2		Address Selectors
	S1 (5..8)	Bus ID High (0x0 ... 0xF). Bit 5 is the LSB, bit 8 the MSB.
	S2 (1..4)	Bus ID Low (0x0 ... 0xF). Bit 1 is the LSB, bit 4 the MSB.
The use of these switches depends on the type of fieldbus which is used. Please see the corresponding manual for further information.		

8.10 S14 Reset Button

S14		Reset Button
	Pressing the Reset Button at power up for 5 seconds, the firmware and parameters are reset, and the system will be in a recovery mode. After this, the firmware must be reinstalled. The reset button is recessed (2mm hole) and must be operated with a tool (e.g. paper clip).	

8.11 System LEDs

LEDs	State Displays		
	Signal:	Color:	Description:
	24VOK	Green	24 VDC Logic Supply OK
	EN (enable)	Yellow	Motor Enabled / Error Code Low Nibble
	WARN	Yellow	Warning / Error Code High Nibble
	ERROR	Red	Error

8.12 RT Bus LEDs

RT Bus LEDs	RT Bus State Display		
	EtherCAT state	ERR (red)	RUN (green)

The blink codes are described in the corresponding interface manuals.

9 System LED Blink Codes

LED Blink Codes			
ERROR	WARN	EN (enable)	Description
OFF	Warning	Operation Enabled	Normal Operation: Warnings and operation enabled are displayed.
ON	● ~2 Hz 0..15 x Error Code High Nibble	● ~2 Hz 0..15 x Error Code Low Nibble	Error: The error code is shown by a blink code with "WARN" and "EN" The error byte is divided into low and high nibble (= 4 bit). "WARN" and "EN" are blinking together. The error can be acknowledged. (e.g.: WARN blinks 3x, EN blinks 2x; Error Code = 32h)
● ~2 Hz	● ~2 Hz 0..15 x Error Code High Nibble	● ~2 Hz 0..15 x Error Code Low Nibble	Fatal Error: The error code is shown by a blink code with "WARN" and "EN". The error byte is divided into low and high nibble. "WARN" and "EN" are blinking together. Fatal errors can only be acknowledged by a reset or power cycle. (e.g.: WARN blinks 3x, EN blinks 2x; Error Code = 32h)
● ~4 Hz	● ~2 Hz 0..15 x Error Code High Nibble	● ~2 Hz 0..15 x Error Code Low Nibble	System Error: Please reinstall firmware or contact support.
● ~0.5 Hz	● ~0.5 Hz	On	Signal Supply 24V too low: The error and warn LEDs blink alternating if the signal supply +24 VDC (X4.2) is less than 18 VDC.
Off	○●●●	●○●●	Plug&Play Communication Active: This sequence (Warn on, then En on, then both off, complete sequence of the 4 states ca. 1 s) signals the state when the plug and play parameters are being read from the motor.
○● ~4 Hz	●○ ~4 Hz	Off	Waiting for Defaulting Parameters: When ID (S1, S2) is set to 0xFF, the drive starts up in a special mode and the Error and Warn LED blink alternating ~4 Hz. When the ID ist set to 0x00, all parameters will be set to their default value. To leave this state, power down the drive and change the ID. Also see in the Usermanual_LinMot-Talk under chapter trouble shooting.
Off	○● ~2 Hz	○● ~2 Hz	Defaulting Parameters Done: When the parameters have set to their default values (initiated via S1/S2 on power up) the Warn and EN LEDs blink together at 2 Hz. To leave this state, power down the drive. Also see in the Usermanual_LinMot-Talk under chapter trouble shooting.

The meaning of the error codes can be found in the *Usermanual_MotionCtrl_Software_SG9* and the user manual of the installed interface software. These documents are provided together with LinMot-Talk configuration software and can be downloaded from www.linmot.com.

10 Safety Wiring

The F1150 drives with the -3S option have internal safety functions:

STO on X4	
Nominal voltage	24V DC
STO release voltage	> 15V
STO activation voltage	< 5V
STO activation time	< 1ms
STO release time	< 5ms
STO Feedback on activation time	< 1ms
STO Feedback on release time	< 5ms

Drive Classification according EN ISO 13849-1 (safety of machinery) PRELIMINARY (TÜV Approval pending)	
Category	cat. = 3
Performance Level	PL = d
Diagnostic Coverage	DC = high (99%)
Mean Time to hazardous failure of one channel	MTTF _d = high (100 years typically, see calculation example below)

DC (Diagnostic Coverage) is high (99%) assuming that the state of the feedback outputs is checked after each change of the state of the control contacts.

If the STO is not used in the application, the STO inputs for channel A and B must be connected to 24VDC.

The low side MOSFETs are active when the STO is activated to shorten the motor phases. This results in an eddy current brake mode. This feature greatly improves the error behavior of the system.

REMARK: The wiring of the 3S safety is different from option 1S.

11 Physical Dimension

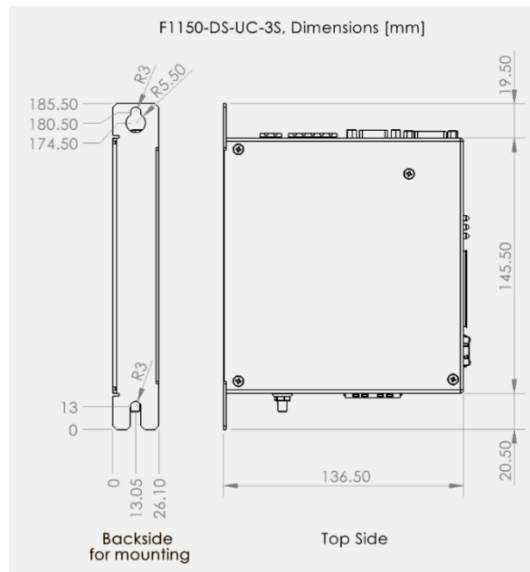

F1150-DS single axis drive		F1150-DS-UC-3S
Width	mm (in)	26.1 (1.03)
Height	mm (in)	145.5 (5.73)
Height with fixings	mm (in)	185.5 (7.30)
Depth	mm (in)	136.5 (5.37)
Weight	g (lb)	765 (1.67)
Mounting Screws		2 x M5
Mounting Distance	mm (in)	167.5 (6.59)
Case, Degree of Protection	IP	20
Storage Temperature	°C	-25...40, maximum change 20 K/hour
Transport Temperature	°C	-20...70
Operating Temperature	°C	5...40 at rated data
Relative humidity		< 85% (non-condensing)
Air pressure	hPa	700...1060
Exposure to ionizing radiation		Not acceptable
Exposure to corrosive environment		Not acceptable
EMC		EN/IEC 61000-6-7 (Functional Safety)
Pollution	IEC/EN 60664-1	Pollution degree 2
Shock resistance (30ms)	g	5
Vibration resistance (10-150Hz)	g	1
Max. Case Temperature	°C	70
Max. Power Dissipation	W	30
Mounting place		In the control cabinet (at least IP54)
Mounting position		Vertical
Distance between Drives	mm (in)	Without Power Derating *: 20 (0.8) horizontal / 50 (2) vertical With Power Derating *: 5 (0.2) horizontal / 20 (0.8) vertical

* The derating is depending on the situation in the cabinet. The temperature of the drive should be checked under full load (the temperature should be stable, which may take an hour or more). This allows to verify that enough margin is there if the cabinet goes to the maximum allowable temperature of 40° C. For example, if the drive temperature reaches 45° C and the cabinet temperature is 30° C, this would result in a drive temperature of about 55° C at a cabinet temperature of 40° C. The warning level of the drive is configured by default to 75° C and the error level to 80° C. In this example, everything is fine. If the drive temperature is long time above the warning level, this might result in a reduced lifetime of the drive.

12 Power Supply Requirements

12.1 Motor-Power Supply

The calculation of the needed power for the motor supply is depending on the application and the used motor.

The nominal supply voltage is 72 VDC.

The possible range is from 24 to 85 VDC.



The motor supply can rise to 95 VDC when braking. This means that everything connected to that power supply needs a dielectric withstand voltage of at least 100 VDC. (Additional capacitors, etc...). Due to high braking voltage and sudden load variations of linear motor applications, **only compatible power supplies can be used (see chapter 14 Ordering Information).**

12.2 Signal-Power Supply

The logic supply needs a regulated power supply of a nominal voltage of 24 VDC. The voltage must be between 22 and 26 VDC.

Current provided from the logic-supply:

- min. 0.5 A (no load on the outputs)
- typ. 0.6 A (output "on" with 100 mA load and brake with no load)
- max. 1.5 A (output "on" with 500 mA peak load and brake with 500 mA peak load)



The 24 VDC supply for the control circuit must be protected with an external fuse (3 A slow blow)

13 Regeneration

Regeneration is done within the drive itself (no external resistor is required).

14 Ordering Information

14.1 Drives

Drives	Description	Art. No.
F1150-DS-UC-3S-000	DS Drive (72V/32A), STO	0150-6489

14.2 Accessories

Accessories	Description	Art. No.
DC01-C1X00/X2	Drive Connector Motor Phases	0150-3526
Compatible Power Supplies	Description	Art. No.
S02-72/1000	Power Supply 72 V/1000 W, 3x400-480 VAC	0150-4535
S01-72/500	Power Supply 72 V/500 W, 1x120/230 VAC	0150-1874
S01-24/500	Power Supply 24 V/500 W, 1x120/230 VAC	0150-2480
T01-72/420-Multi	T-Supply 72 V / 420 VA, 3x230/400/480 VAC	0150-1869
T01-72/900-Multi	T-Supply 900 VA, 3x230/400/480 VAC	0150-1870
T01-72/1500-Multi	T-Supply 1500 VA, 3x230/400/480 VAC	0150-1871
T01-72/420 -1ph	T-Supply 420 VA, 1x208/220/230/240 VAC	0150-1859



The connectors X1 and X4 are delivered together with the drive! The connector X2 is included on the motor cable.

15 International Certifications

Certifications	
Europe 	See chapter 15.1 EU Declaration of Conformity CE Marking
UK 	See chapter 15.2 UK Declaration of Conformity UKCA Marking
cULus - pending	The F1150-DS-UC-3S-xxx will be listed according UL61800-5-1 (pending, this is planned to be done until the end of the year 2025)

15.1 EU Declaration of Conformity CE Marking

NTI AG / LinMot[®]

Bodenaeckerstrasse 2

8957 Spreitenbach

Switzerland

Tel.: +41 (0)56 419 91 91

Fax: +41 (0)56 419 91 92

declares under sole responsibility the compliance of the products:

- Drives of the Series **F1150-DS-UC-3S-xxx**

with the EMC Directive 2014/30/EU.

Applied harmonized standards:

- EN 61800-3:2004 + A1:2012
- EN 61800-3:2018

According to the EMC directive, the listed devices are not independently operable products.

Compliance of the directive requires the correct installation of the product, the observance of specific installation guides and product documentation. This was tested on specific system configurations.

The safety instructions of the manuals are to be considered.

The product must be mounted and used in strict accordance with the installation instructions contained within the installation guide, a copy of which may be obtained from NTI AG.

Company: NTI AG

Spreitenbach, 14.10.2024



Dr. Ronald Rohner / CEO NTI AG

15.2 UK Declaration of Conformity UKCA Marking

NTI AG / LinMot[®]

Bodenaeckerstrasse 2

8957 Spreitenbach

Switzerland

Tel.: +41 (0)56 419 91 91

Fax: +41 (0)56 419 91 92

declares under sole responsibility the compliance of the products:

- Drives of the Series **F1150-DS-UC-3S-xxx**

with the EMC Regulation S.I. 2016 No. 1091.

Applied designated standards:

- EN 61800-3:2004 + A1:2012
- EN 61800-3:2018

According to the EMC regulation, the listed devices are not independently operable products.

Compliance of the regulation requires the correct installation of the product, the observance of specific installation guides and product documentation. This was tested on specific system configurations.

The safety instructions of the manuals are to be considered.

The product must be mounted and used in strict accordance with the installation instructions contained within the installation guide, a copy of which may be obtained from NTI AG.

Company: NTI AG

Spreitenbach, 14.10.2024



Dr. Ronald Rohner / CEO NTI AG

16 Version history

Version	Change	Date
1.0	Initial version	06.12.2024
1.1	CAN connector X79 added	30.01.2025
1.2	Control frequencies specified, RMS current (preliminary), STO wiring 3S to 1S different	12.02.2025
1.3	LED description with better pictures / PE replaced by IEC symbol (UL does not allow the marking with PE)	13.02.2025

ALL LINEAR MOTION FROM A SINGLE SOURCE

17 Contact information

Europe / Asia Headquarters

NTI AG - LinMot & MagSpring

Bodenaeckerstrasse 2
CH-8957 Spreitenbach
Switzerland

Sales / Administration: +41 56 419 91 91
office@linmot.com

Technical Support: +41 56 544 71 00
support@linmot.com

Web: <https://www.linmot.com>

North / South America Headquarters

LinMot USA Inc.

N1922 State Road 120, Unit 1
Lake Geneva, WI 53147
USA

Sales / Administration: 262.743.2555
usasales@linmot.com

Technical Support: 262.743.2555
usasupport@linmot.com

Web: <https://www.linmot-usa.com>

Visit <https://linmot.com/contact/> to find a distributor near you.