

LinMot[®]



Modular Multi Axis System M8050

Installation Guide

M8050-xx-XC-H-1S-S02-F01-XX

© 2018 NTI AG

This work is protected by copyright.

Under the copyright laws, this publication may not be reproduced or transmitted in any form, electronic or mechanical, including photocopying, recording, microfilm, storing in an information retrieval system, not even for didactical use, or translating, in whole or in part, without the prior written consent of NTI AG.

LinMot® is a registered trademark of NTI AG.

The information in this documentation reflects the stage of development at the time of press and is therefore without obligation. NTI AG reserves itself the right to make changes at any time and without notice to reflect further technical advance or product improvement.

Table of Content

1 Important Notes for Multi Axis Systems M8050.....4

2 Interfaces..... 5

3 System Overview.....6

Functionality.....7

4 Software.....7

5 Power Supply and Grounding.....8

6 Description of the connectors / Interfaces.....9

 6.1 PE.....9

 6.2 X3.....9

 6.3 X17-X18.....10

 6.4 X19.....10

 6.5 X34.....10

 6.6 X33.....11

 6.7 X36.....11

 6.8 S1 - S2.....11

 6.9 LED.....11

 6.10 RT BUS LED.....12

7 Safety Wiring.....13

8 Physical Dimension.....14

9 Power Supply Requirement.....15

10 Configurations.....16

11 Ordering Information.....17

12 Contact Addresses.....18

1 Important Notes for Multi Axis Systems M8050

CAUTION!



In order to assure a safe and error free operation, and to avoid severe damage to system components, all system components must be directly attached to a single ground bus that is earth or utility grounded.



Each system component should be tied directly to the ground bus (star pattern), rather than daisy chaining from component to component. (LinMot motors are properly grounded through their power cables when connected to LinMot drives).



All connectors must not be connected or disconnected while DC voltage is applied. Do not disconnect system components until all LinMot drives LEDs have turned off. (Capacitors in the power supply may not fully discharge for several minutes after input voltage has been disconnected). Failure to observe these precautions may result in severe damage to electronic components in LinMot motors and/or drives.



Do not switch Power Supply DC Voltage. All power supply switching and E-Stop breaks should be done to the AC supply voltage of the power supply.



Do not connect or disconnect the motors from drives while voltage is applied. Wait to connect or disconnect motors until all LinMot drives LEDs have turned off. (Capacitors may not fully discharge for several minutes after power has been turned off). Failure to observe these precautions may result in severe damage to electronic components in LinMot motors and/or drives.

2 Interfaces

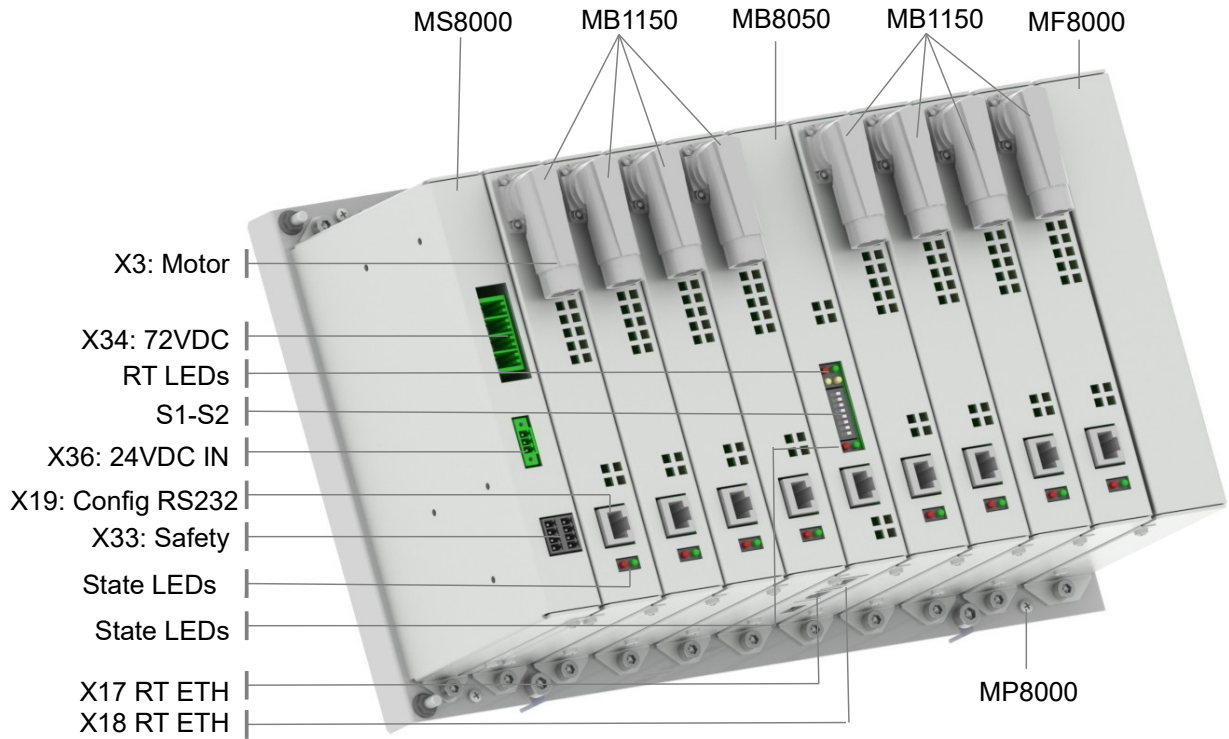

3 System Overview

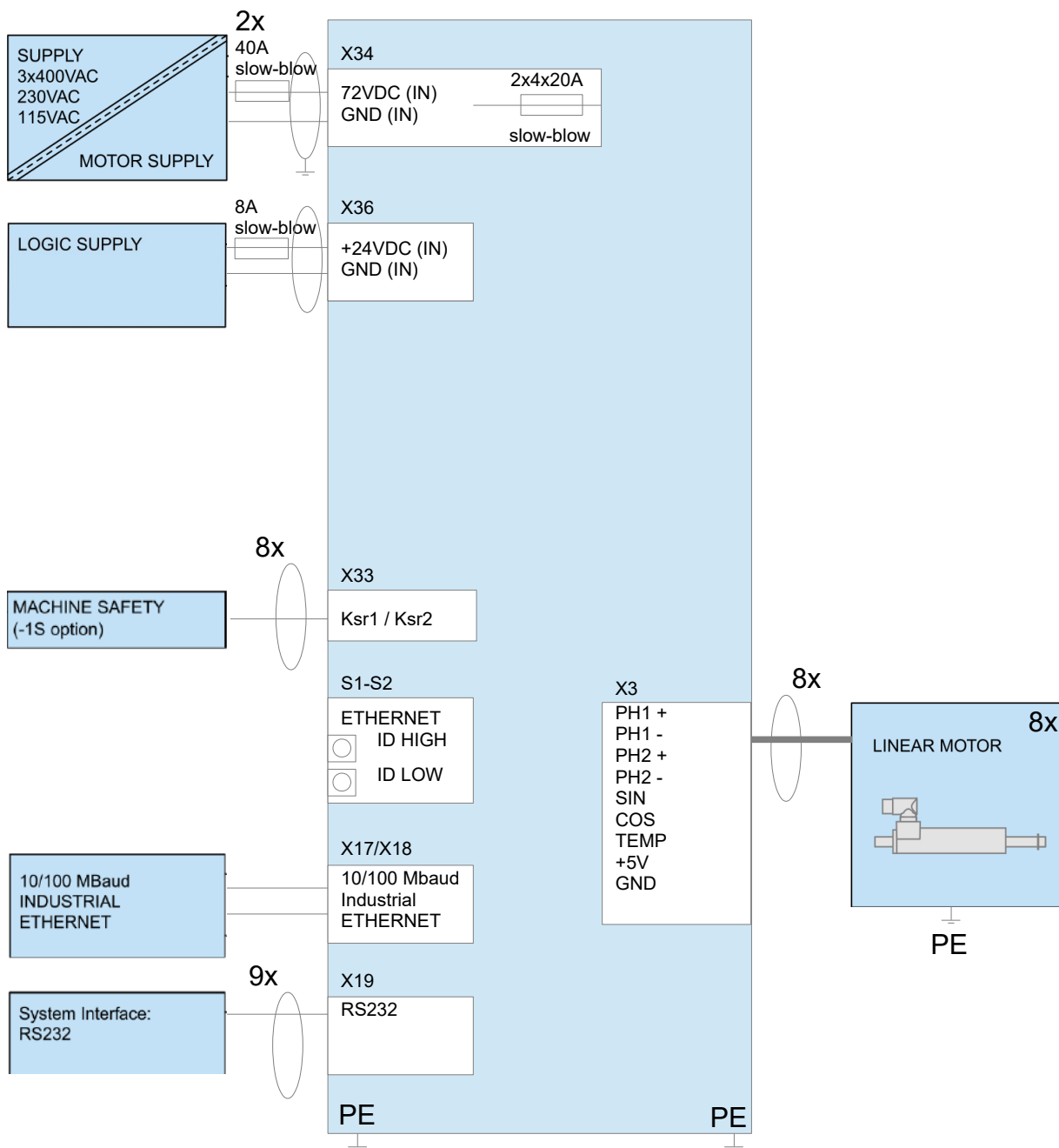

Multiaxis Module Install. Guide

Functionality

Supply Voltage	
	Motor Supply 72VDC (24...85VDC)
	Logic Supply 24VDC (22...26VDC)
Motor Phase Current	
	25A _{peak} / 15A _{rms}
Controllable Motors	
LinMot	P01-23x...
	P01-37x...
	P01-48x...
	PR01-52x...
	PR01-84x...
Command Interface	
	EtherCAT
	ProfiNet
Command Mode	
	Streaming Mode (P, PV)
Configuration	
	RS232 Configuration

4 Software

The configuration software LinMot-Talk is free of charge and can be downloaded from the LinMot homepage (www.LinMot.com).

5 Power Supply and Grounding



In order to assure a safe and error free operation and to avoid severe damage to system components, **all system components* must be well grounded to either a single earth or utility ground.** This includes both LinMot and all other control system components to the same ground bus.



Each system component* should be tied directly to the ground bus (**star pattern**), rather than daisy chaining from component to component. (LinMot motors are properly grounded through their power cables when connected to LinMot drives.)



Power supply connectors must not be connected or disconnected while DC voltage is present. Do not disconnect system components until all LinMot drives LEDs have turned off. (Capacitors in the power supply may not fully discharge for several minutes after input voltage has been disconnected). Failure to observe these precautions may result in severe damage to electronic components in LinMot motors and/or drives.



Do not switch Power Supply DC Voltage. All power supply switching and E-Stop breaks should be done to the AC supply voltage of the power supply. Failure to observe these precautions may result in severe damage to drive.

* Inside of the MB1150 drives the *PWR motor GND* and *PWR signal GND* is connected together and to the GND of the drive housing. It is recommended that the *PWR motor GND* is NOT grounded at another place than inside of the drive to avoid circular currents.

6 Description of the connectors / Interfaces

6.1 PE

PE	Protective Earth
PE	<ul style="list-style-type: none"> • Use both PE screws • Use min. 4mm² (AWG11) • Tightening torque: 2Nm (18 lbin)

6.2 X3

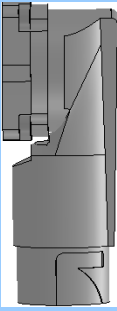
X3	Motor (H-Connector)	On MB1150
	<p>LinMot Motor:</p> <ul style="list-style-type: none"> A Motor Phase 1+ B Motor Phase 1- C Motor Phase 2+ D/PE Motor Phase 2- 1 +5VDC 2 AGND 3 Sensor Sine 4 Sensor Cosine 5 Temp. In 	
ITec9 (modified)	<p>Note: Use +5V (X3.1) and AGND (X3.2) only for motor internal hall sensor supply (max. 100mA). Cable length < 30m. For XC ratings, use only 1.5mm² (AWG 16) cable (phase connections)</p> <p>Caution: Do NOT connect AGND (X3.2) to ground or earth!</p> <p>⚠ Attention: No Protective Earth connection to the motor is provided thru this connector: Motor must be separately connected to PE!</p>	

6.3 X17-X18

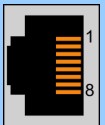
X17 - X18	RealTime Ethernet 10/100Mbit/s	On MB8050
	X18 RT ETH In	Specification depends on RT-Bus type. Please refer to according documentation.
	X17 RT ETH Out	

6.4 X19

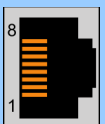
X19	RS Config	On MB1150 & MB8050
	<ul style="list-style-type: none"> 1 (Do not connect) 2 (Do not connect) 3 RS232 Rx 4 GND 5 GND 6 RS232 Tx 7 (Do not connect) 8 (Do not connect) 	
	case Shield	
RJ-45	Use isolated USB-RS232 converter (Art.-No. 0150-2473) for configuration over RS232.	

6.5 X34

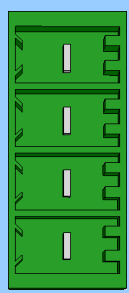
X34	Motor Supply Power IN	On MS8000
	<ul style="list-style-type: none"> PIN 1 DC- axis 1..4 PIN 2 DC- axis 5..8 PIN 3 DC+ axis 1..4 (external fuse max. 40A slow-blow / 100VDC required) PIN 4 DC+ axis 5..8 (external DC fuse max. 40A slow-blow / 100VDC required) 	
	Screw Terminals	

6.6 X33

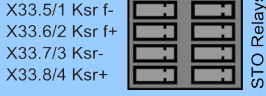
X33	Safety Relays (only with the -1S option)	On MS8000	
	PIN 1	Ksr f-	Safety Relay 1 feedback negative
	PIN 2	Ksr f+	Safety Relay 1 feedback positive
	PIN 3	Ksr -	Safety Relay 1 Input negative
	PIN 4	Ksr +	Safety Relay 1 Input positive
	PIN 5	Ksr f-	Safety Relay 2 feedback negative
	PIN 6	Ksr f+	Safety Relay 2 feedback positive
	PIN 7	Ksr -	Safety Relay 2 Input negative
	PIN 8	Ksr +	Safety Relay 2 Input positive
	Supply 24V - Conductor cross-section max. 1.5mm ² (AWG 16) - Use 60/75°C copper conductors only - Stripping length: 10mm		

6.7 X36

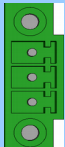
X36	Logic Power 24VDC IN	On MS8000
	PIN 1	GND
	PIN 2	24VDC (external DC fuse 8A slow-blow required)
	PIN 3	Dig In
Supply 24V - Tightening torque: min 0.22 Nm (2 lbin) - Use 60/75°C copper conductors only - Conductor cross-section: use only 1.5mm ² (AWG 16) - 24VDC: external Fuse max. 8 A slow-blow required		

6.8 S1 - S2

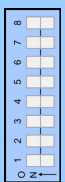
S1 - S2	Address Selectors	On MB8050
	S1	Bus ID High (0 ... F)
	S2	Bus ID Low (0 ... F)
The use of these switches depends on the type of fieldbus which is used. Please see the corresponding manual for further information.		

6.9 LED

LED	State Display	On MB1150 & MB8050
	Green Red	24V Logic Supply OK Error

6.10 RT BUS LED

RT Bus LED	RT Bus State Display		On MB8050
	Green Red	OK Error	
The use of these LEDs depends on the type of fieldbus which is used. Please see the corresponding manual for further information.			

7 Safety Wiring

The M8000 Module with the -1S option has internal safety functions:

Two Safety relays Ksr in series, which support the supply voltage for the motor drivers. There are also two feedback contacts for each relay.

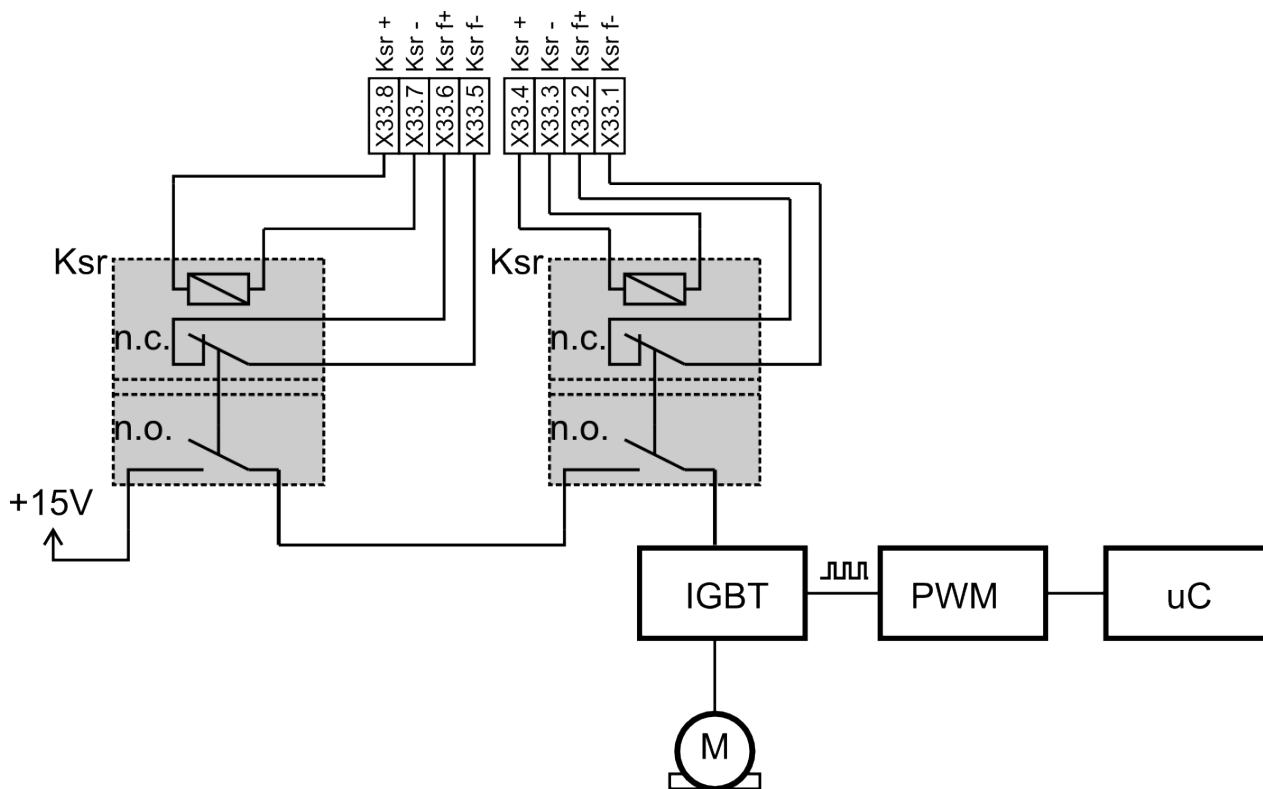

To enable the -1S drives both relays have to be switched on.

Minimal wiring:

- Connect X33.8 and X33.4 to 24VDC (from safety)
- Connect X33.7 and X33.3 to GND (from safety)



Attention: Never connect X33.8 and X33.4 to the logic supply of X36!

Safety Relay Ksr	
Nominal voltage	24 VDC
Min. pick-up voltage at 20°C	≤ 16.8V
Drop-out voltage at 20°C	≥ 2.4 V
Coil resistance at 20°C	2'100 Ω ± 10%
Type	EN 50205, type A

8 Physical Dimension



Width	mm (in)	340 (13.4)
Height	mm (in)	230 (9.1)
Depth	mm (in)	158 (6.25)
Spacing around Backplane	mm(in)	20 (0.8)
Weight	kg (lb)	10.5 (23.2)
Case	IP	20
Storage Temperature	°C	-25...40
Transport Temperature	°C	-25...70
Operating Temperature	°C	0...40 at rated data
Relative humidity		95% (non-condensing)
Shock resistance (16ms)	m/s ²	35
Vibration resistance (10-200Hz)	m/s ²	10
Max. Case Temperature	°C	70
Max. Power Dissipation	W	

9 Power Supply Requirement

Signal Supply

The logic supply needs a regulated power supply with a nominal voltage of 24 VDC. The voltage must be between 22 and 26 VDC.

Power Consumption for logic supply

- 12W per axis module
- 6W per bus module
- 18W per fan module
- Total: 120W (8x axis module, 1x bus module, 1x fan module)

Power Consumption of the safety relays

- 0.3W per relays / 2 relays per axis module
- Total: 4.8W* (16x safety relays)
*this value might be increased up to 12W in future revisions!



DO NOT CONNECT THE SAFETY RELAYS TO THE 24VDC SIGNAL SUPPLY!
USE A SEPERATE POWER SUPPLY FOR THE SAFETY CIRCUIT!

10 Configurations

The M8050 Systems are also available with less than 8 axis. Instead of a MB1150 axis module a MB0000 place holder module will be inserted. The position of the place holder modules is relevant. The following pictures illustrate the different configurations:

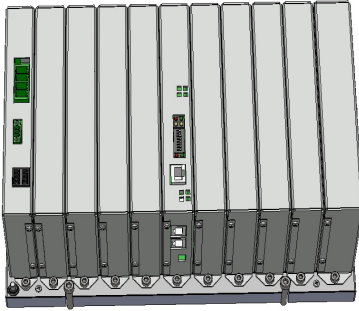

M8050-...-00

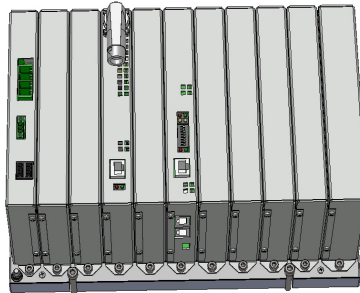

M8050-...-01

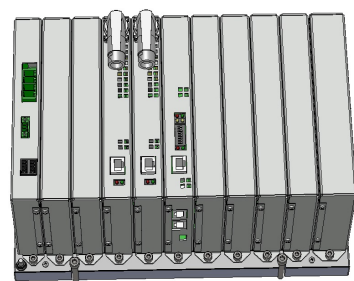

M8050-...-02

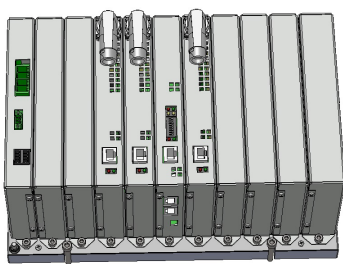

M8050-...-03

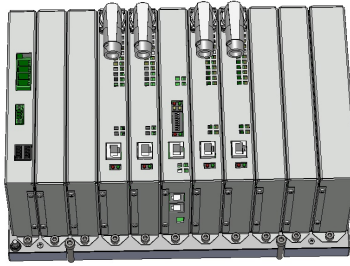

M8050-...-04

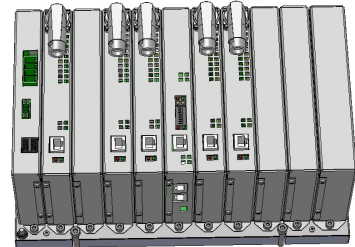

M8050-...-05

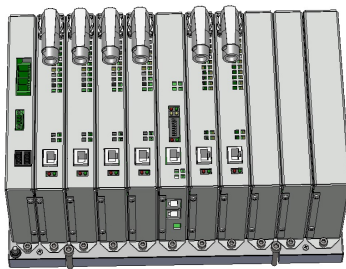

M8050-...-06

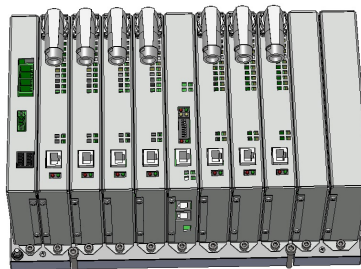

M8050-...-07



M8050-...-08

11 Ordering Information

Controller	Description	Art. No.
M8050-EC-XC-1S-H-S02-F01-08	8 Axis Multiaxis System M8050 Interface: PROFINET Safety Function: 1S	0150-2066
M8050-IP-XC-1S-H-S02-F01-08	8 Axis Multiaxis System M8050 Interface: ETHERNET IP Safety Function: 1S	0150-2067
M8050-PN-XC-1S-H-S02-F01-08	8 Axis Multiaxis System M8050 Interface: PROFINET Safety Function: 1S	0150-2068
M8050-PN-XC-1S-H-S02-F01-06	6 Axis Multiaxis System M8050 Interface: PROFINET Safety Function: 1S	0150-2099
M8050-PL-XC-1S-H-S02-F01-06	6 Axis Multiaxis System M8050 Interface: POWERLINK Safety Function: 1S	0150-2087
M8050-PL-XC-1S-H-S02-F01-08	8 Axis Multiaxis System M8050 Interface: POWERLINK Safety Function: 1S	0150-2079
For other configurations: Please contact LinMot		
Accessories	Description	Art. No.
DC01-EM8000/X33/X34/X36	Connector Set Including Connectors for X33, X34 and X36	0150-3524
Isolated USB-RS232 converter	Isolated USB RS232 converter with config. cable	0150-2473

12 Contact Addresses

SWITZERLAND

NTI AG

Bodenaeckerstrasse 2
CH-8957 Spreitenbach

Sales and Administration: +41-(0)56-419 91 91
office@linmot.com

Tech. Support: +41-(0)56-544 71 00
support@linmot.com

Tech. Support (Skype) : skype:support.linmot

Fax: +41-(0)56-419 91 92

Web: <http://www.linmot.com/>

USA

LinMot USA, Inc.

N1922 State Road 120, Unit 1
Lake Geneva, WI 53147

Phone: 262-743-2555

E-Mail: usasales@linmot.com

Web: <http://www.linmotusa.com/>

Please visit <http://www.linmot.com/> to find the distributor closest to you.

Smart solutions are...

