

LinMot®



E1200 Servo Drive Installation Guide

© 2022 NTI AG

This work is protected by copyright.

Under the copyright laws, this publication may not be reproduced or transmitted in any form, electronic or mechanical, including photocopying, recording, microfilm, storing in an information retrieval system, not even for didactical use, or translating, in whole or in part, without the prior written consent of NTI AG.

LinMot® is a registered trademark of NTI AG.

The information in this documentation reflects the stage of development at the time of press and is therefore without obligation. NTI AG reserves itself the right to make changes at any time and without notice to reflect further technical advance or product improvement.

Table of Content

1	Important Safety Notes for E1200 Series Drives	4
2	System Overview	5
3	Functionality and Interfaces	6
4	IP Address Selection	6
5	Power Supply and Grounding	7
6	Description of the connectors / Interfaces	8
6.1	PE	8
6.2	X1	8
6.3	X2	9
6.4	X3	9
6.5	X4	10
6.6	X7 - X8	10
6.7	X9	11
6.8	X10 - X11	11
6.9	X13	12
6.10	X15 - X16	12
6.11	X17 - X18	13
6.12	X19	13
6.13	X20	13
6.14	S5	14
6.15	LEDs	14
6.16	RT BUS LEDs	14
6.17	S1 - S2	14
7	Error Codes	15
8	Physical Dimensions	16
9	Power Supply Requirements	17
10	Regeneration of Power / Regeneration Resistor	18
11	Ordering Information	18
12	International Certifications	19
13	EU Declaration of Conformity CE-Marking	21
14	UK Declaration of Conformity UKCA-Marking	22
15	Contact Addresses	23

1 Important Safety Notes for E1200 Series Drives**CAUTION!**

In order to assure a safe and error free operation, and to avoid severe damage to system components, all system components must be directly attached to a single ground bus that is earth or utility grounded (see chapter 5 Power Supply and Grounding).



Each system component should be tied directly to the ground bus (star pattern), rather than daisy chaining from component to component. (LinMot motors are properly grounded through their power cables when connected to LinMot drives) (see chapter 5 Power Supply and Grounding).



All connectors must not be connected or disconnected while DC voltage is present. Do not disconnect system components until all LinMot drive LEDs have turned off. (Capacitors in the power supply may not fully discharge for several minutes after input voltage has been disconnected). Failure to observe these precautions may result in severe damage to electronic components in LinMot motors and/or drives.



Do not switch Power Supply DC Voltage. All power supply switching and E-Stop breaks should be done to the AC supply voltage of the power supply.



Do not connect or disconnect the motors from drives with voltage present. Wait to connect or disconnect motors until all LinMot drives LEDs have turned off. (Capacitors may not fully discharge for several minutes after power has been turned off).

Failure to observe these precautions may result in severe damage to electronic components in LinMot motors and/or drives.

2 System Overview

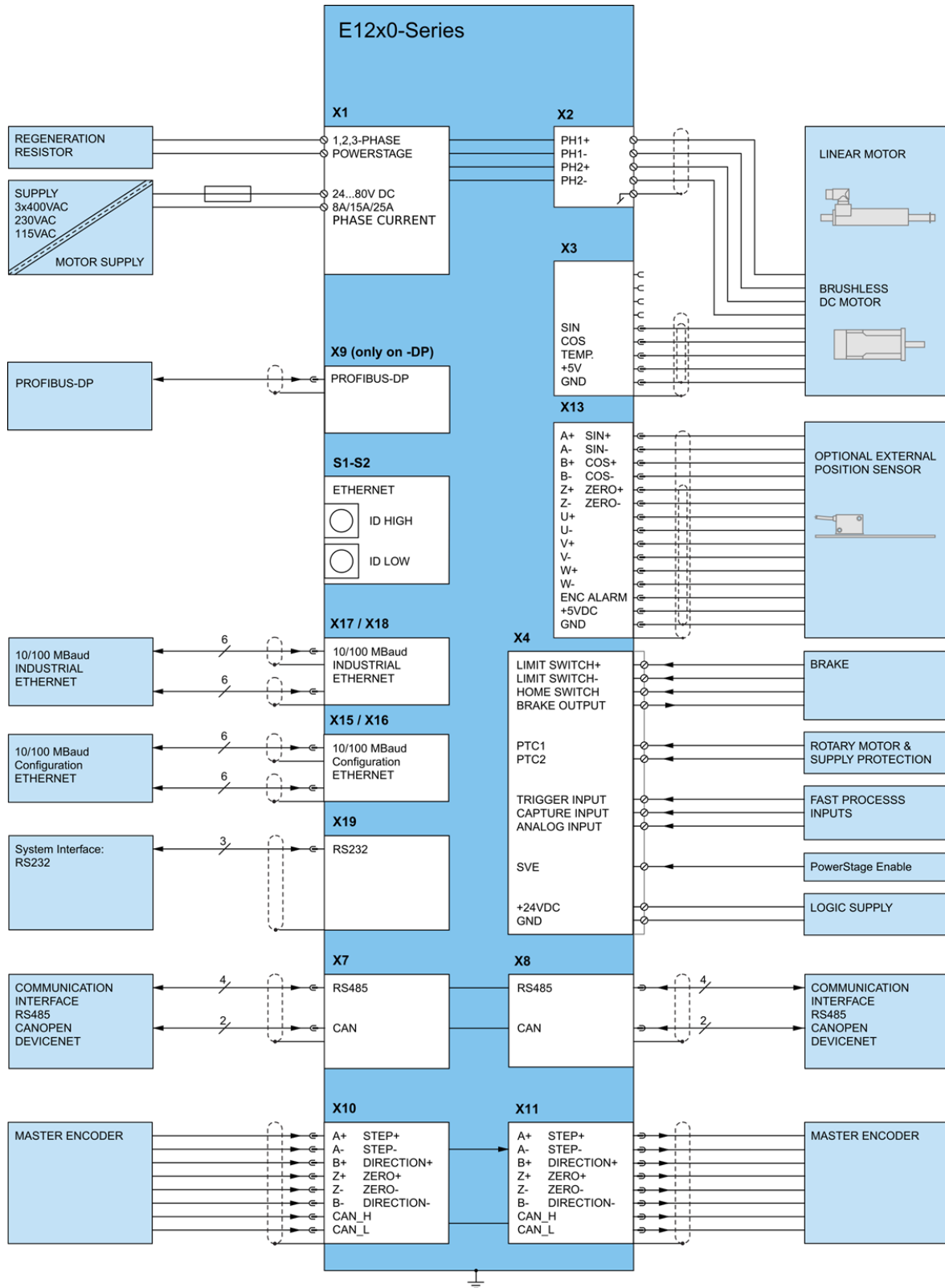

Typical servo system E12x0-XX: Servo drive, linear motor and power supply.

3 Functionality and Interfaces

	E1250-PL-JC	E1250-PN-JC	E1250-PD-JC	E1250-SC-JC	E1250-IP-JC	E1250-LU-JC	E1250-EC-JC	E1250-SE-JC	E1250-DS-JC	E1230-DP-JC	E1200-GP-JC
Supply Voltage											
Motor Supply 72VDC (24...85VDC)	•	•	•	•	•	•	•	•	•	•	•
Logic Supply 24VDC (22...26VDC)	•	•	•	•	•	•	•	•	•	•	•
Motor Phase Current											
32A _{peak} / 12A _{rms} (0..599Hz)	•	•	•	•	•	•	•	•	•	•	•
Controllable Motors											
LinMot P01-23x... (Motor Link P)*	•	•	•	•	•	•	•	•	•	•	•
P01-37x... (Motor Link P)*	•	•	•	•	•	•	•	•	•	•	•
P01-48x... (Motor Link P)*	•	•	•	•	•	•	•	•	•	•	•
DC Motors	•	•	•	•	•	•	•	•	•	•	•
Brushless DC / EC Motors	•	•	•	•	•	•	•	•	•	•	•
Command Interface											
CANopen											•
LinRS											•
POWERLINK	•										
PROFINET		•									
PROFINET Profidrive			•								
sercos				•							
sercos over EtherCAT								•			
ETHERNET IP					•						
LinUDP						•					
EtherCAT							•				
ETHERCAT CiA402									•		
PROFIBUS-DP										•	
Programmable Motion Profiles (Curves)											
Up to 100 Motion Profiles, up to 16302 curve points	•	•	•	•	•	•	•	•	•	•	•
Programmable Command Table											
Command Table with up to 255 entries	•	•	•	•	•	•	•	•	•	•	•
External Position Sensor											
Incremental (RS422 up to 25 M counts/s, quadrature ev.)	•	•	•	•	•	•	•	•	•	•	•
Synchronisation											
Master Encoder In/Out (RS422 up to 25 M counts/s, quadrature ev.)	•	•	•	•	•	•	•	•	•	•	•
Configuration Interface											
RS232	•	•	•	•	•	•	•	•	•	•	•
Ethernet 10/100 Mbit/s (2-Port Switch integrated)	•	•	•	•	•	•	•	•	•	•	•

4 IP Address Selection

The default mode for acquiring an IP address is via DHCP. If no servers respond on the connect network, the drive switches to the Ipv4 Link-Local addressing scheme (also known as APIPA on Windows systems). This way the drive automatically assigns itself an address within the range of 169.254.0.1 through 169.254.255.254 (Subnet Mask 255.255.0.0).

Please note that this process can take up to a minute until a valid address is assigned to the drive.

*LinMot Motor Communication

5 Power Supply and Grounding

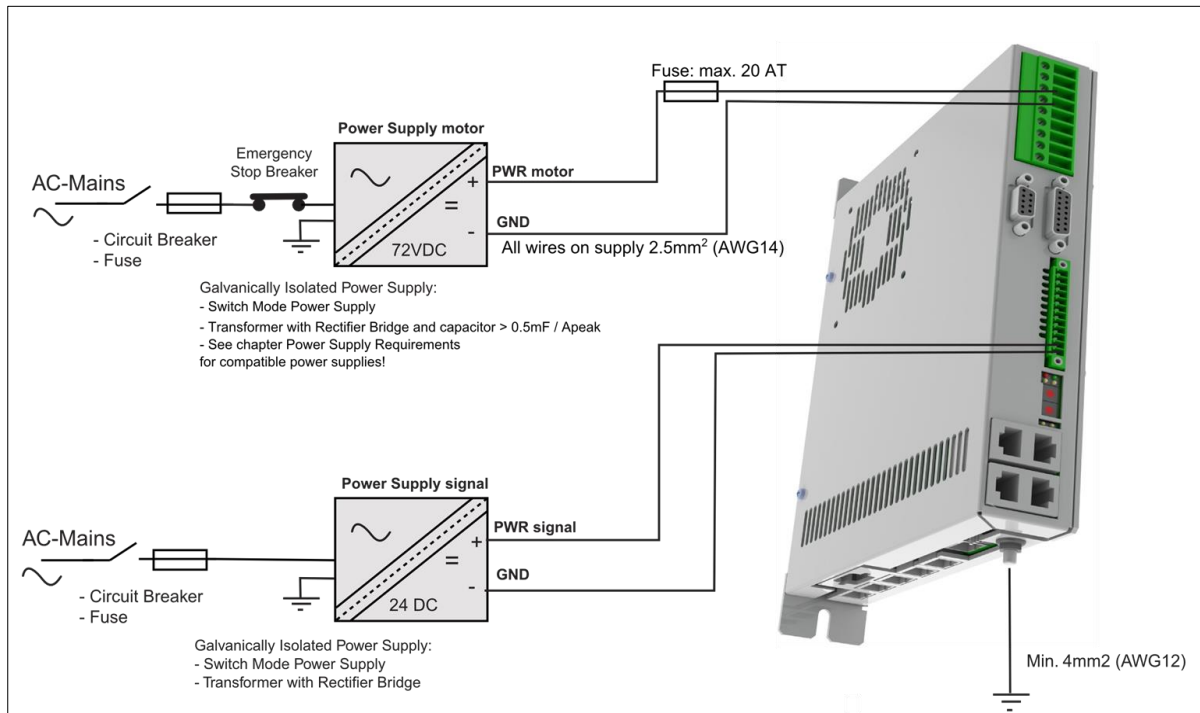

In order to assure a safe and error free operation, and to avoid severe damage to system components, all system components* must be well grounded to either a single earth or utility ground. This includes both LinMot and all other control system components on the same ground bus.

Each system component* should be tied directly to the ground bus (**star pattern**), rather than daisy chaining from component to component. (LinMot motors are properly grounded through their power cables when connected to LinMot drives.)

Power supply connectors must not be connected or disconnected while DC voltage is present. Do not disconnect system components until all LinMot drive LEDs have turned off. (Capacitors in the power supply may not fully discharge for several minutes after input voltage has been disconnected). Failure to observe these precautions may result in severe damage to electronic components in LinMot motors and/or drives.

Do not switch Power Supply DC Voltage. All power supply switching and E-Stop breaks should be done to the AC supply voltage of the power supply. Failure to observe these precautions may result in severe damage to the drive.

* Inside of the E1200 drive the *PWR motor GND* and *PWR signal GND* is connected together and to the GND of the drive housing. It is recommended that the *PWR motor GND* is NOT grounded at another place than inside of the drive to reduce circular currents.

6 Description of the connectors / Interfaces

6.1 PE

PE	Protective Earth
PE	<ul style="list-style-type: none"> Use min. 4mm² (AWG11) Tightening torque: 2Nm (18 lbin)

6.2 X1

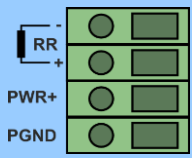
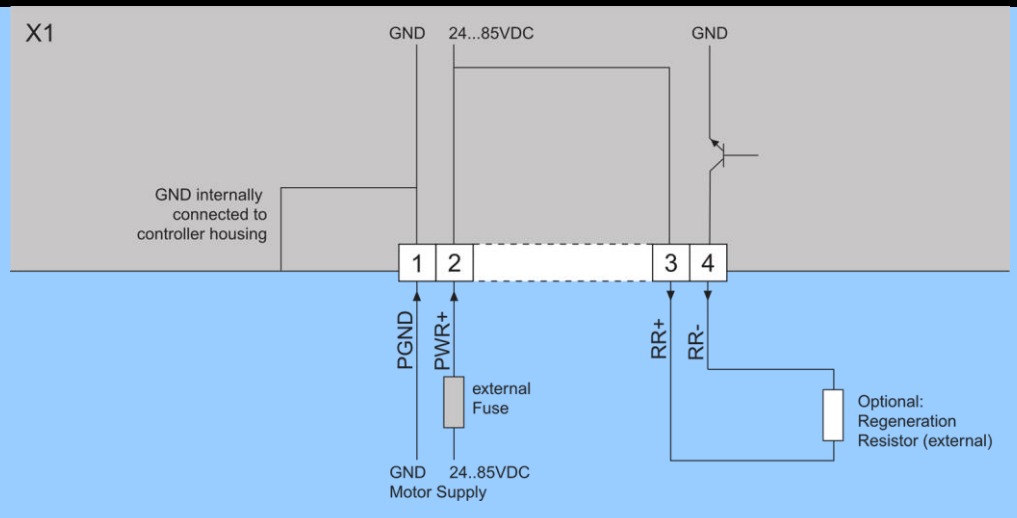
X1	Motor Supply / Regeneration Resistor
	
Screw Terminals	<p>External Regeneration Resistor (RR01-10/60, Art. Nr. 0150-3088)</p> <p>External Fuse: max. 20A slow-blow</p> <p>Supply nominal 72VDC (24...85VDC) (See chapter Power Supply Requirements for compatible power supplies.)</p> <p>Absolute max. Rating 72VDC +20%.</p> <p>If motor supply voltage is exceeds 90VDC, the drive will go into error state.</p> <ul style="list-style-type: none"> - Tightening torque: 0.5 - 0.6 Nm (4.4 – 5.3 lbin) - Screw thread: M2.5 - Use 60/75°C copper conductors only - Conductor cross-section: use only 2.5mm² / AWG 14 - Stripping length: 13-15mm - Max. length: 4m

6.3 X2

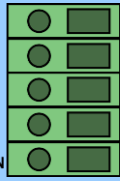
X2 Motor Phases																									
	<table border="0"> <tr> <td>PH1+</td> <td>/U</td> <td>LinMot Motor:</td> <td>3-phase EC-Motor:</td> </tr> <tr> <td>PH1-</td> <td>/V</td> <td>Motor Phase 1+</td> <td>Motor Phase U</td> </tr> <tr> <td>PH2+</td> <td>/W</td> <td>Motor Phase 1-</td> <td>Motor Phase V</td> </tr> <tr> <td>PH2-</td> <td>/X</td> <td>Motor Phase 2+</td> <td>Motor Phase W</td> </tr> <tr> <td>SCRN</td> <td></td> <td>Motor Phase 2-</td> <td>Motor Phase X</td> </tr> <tr> <td></td> <td></td> <td>Shield</td> <td></td> </tr> </table>	PH1+	/U	LinMot Motor:	3-phase EC-Motor:	PH1-	/V	Motor Phase 1+	Motor Phase U	PH2+	/W	Motor Phase 1-	Motor Phase V	PH2-	/X	Motor Phase 2+	Motor Phase W	SCRN		Motor Phase 2-	Motor Phase X			Shield	
PH1+	/U	LinMot Motor:	3-phase EC-Motor:																						
PH1-	/V	Motor Phase 1+	Motor Phase U																						
PH2+	/W	Motor Phase 1-	Motor Phase V																						
PH2-	/X	Motor Phase 2+	Motor Phase W																						
SCRN		Motor Phase 2-	Motor Phase X																						
		Shield																							
Screw Terminals	<ul style="list-style-type: none"> - Tightening torque: 0.5 - 0.6 Nm (4.4 – 5.3 lbin) - Screw thread: M2.5 - Use 60/75°C copper conductors only - Conductor cross-section: 0.5 – 2.5mm² (depends on Motor current) / AWG 21 -14 - Stripping length 13-15mm 																								

6.4 X3

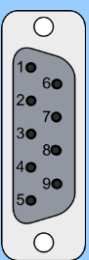
X3 Motor Encoder																																		
	<table border="0"> <tr> <td></td> <td>LinMot Motor:</td> <td>3-phase EC-Motor:</td> </tr> <tr> <td>1</td> <td>-</td> <td>-</td> </tr> <tr> <td>2</td> <td>-</td> <td>-</td> </tr> <tr> <td>3</td> <td>+5VDC</td> <td>+5VDC (Hall Supply)</td> </tr> <tr> <td>4</td> <td>Sensor Sine</td> <td>Hall 1</td> </tr> <tr> <td>5</td> <td>Temp. In</td> <td>Hall 3</td> </tr> <tr> <td>6</td> <td>-</td> <td>-</td> </tr> <tr> <td>7</td> <td>-</td> <td>-</td> </tr> <tr> <td>8</td> <td>AGND</td> <td>AGND (Hall Supply)</td> </tr> <tr> <td>9</td> <td>Sensor Cosine</td> <td>Hall 2</td> </tr> <tr> <td>case</td> <td>Shield</td> <td></td> </tr> </table>		LinMot Motor:	3-phase EC-Motor:	1	-	-	2	-	-	3	+5VDC	+5VDC (Hall Supply)	4	Sensor Sine	Hall 1	5	Temp. In	Hall 3	6	-	-	7	-	-	8	AGND	AGND (Hall Supply)	9	Sensor Cosine	Hall 2	case	Shield	
	LinMot Motor:	3-phase EC-Motor:																																
1	-	-																																
2	-	-																																
3	+5VDC	+5VDC (Hall Supply)																																
4	Sensor Sine	Hall 1																																
5	Temp. In	Hall 3																																
6	-	-																																
7	-	-																																
8	AGND	AGND (Hall Supply)																																
9	Sensor Cosine	Hall 2																																
case	Shield																																	
DSUB-9 (f)	<p>Note: Use +5VDC (X3.3) and AGND (X3.8) only for motor internal hall sensor supply (max. 100mA).</p> <p>Caution: Do NOT connect AGND (X3.8) to ground or earth!</p>																																	

Motor Wiring

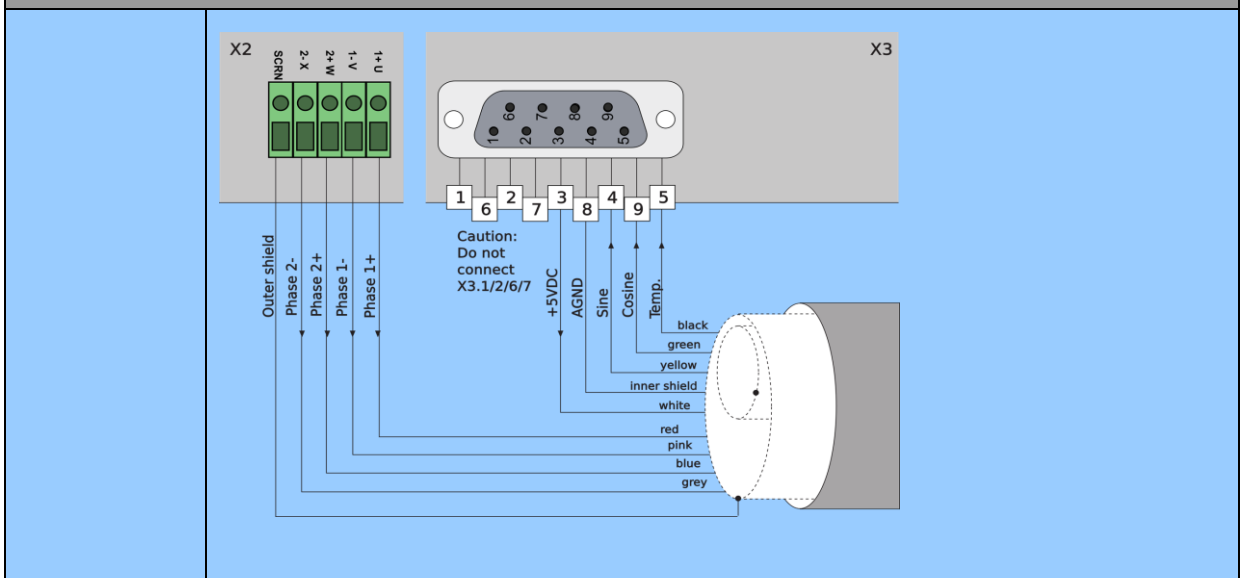

6.5 X4

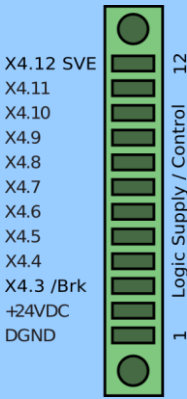
X4		Logic Supply / Control		
	12	Input	SVE	Power Stage Enable (HW Enable)
	11	I/O	X4.11	Configurable IO, PTC2 Input
	10	I/O	X4.10	Configurable IO, PTC1 Input
	9	I/O	X4.9	Configurable IO
	8	I/O	X4.8	Configurable IO
	7	I/O	X4.7	Configurable IO, Analog Input for EasySteps Application
	6	I/O	X4.6	Configurable IO, Trigger Input
	5	I/O	X4.5	Configurable IO
	4	I/O	X4.4	Configurable IO, Analog Input (configurable as high imp. Input)
	3	I/O	X4.3/Brk	Configurable IO, Brake Driver 1A
	2	+24VDC	Supply	Logic Supply 22-26 VDC
	1	GND	Supply	Ground
Phoenix MC1,5/12-STF-3,5 (delivered with drive)	Inputs (X4.3 .. X4.12):	24V / 5mA (Low Level: -0.5 to 5VDC, High Level: 15 to 30VDC)		
	Outputs (X4.4 .. X4.11):	24V / max.100mA, Peak 370mA (will shut down if exceeded)		
	Brake Output (X4.3):	24V / max.1.0A		
	Input X4.12: SVE (PowerStageEnable) must be high for enabling the power stage. . If it goes low for more than 0.5ms the PWM generation of the power stage is disabled by hardware.			
	Supply 24V / typ. 1.1A / max. 2.1A (if all outputs "on" with max. load and brake.)			
	- Tightening torque: min 0.22Nm			
	- Screw thread: M2			
	- Use 60/75°C copper conductors only			
	- Conductor cross-section max. 1.5mm ²			
	- Internal Fuse (F2): 3A slow blow (Schurter OMT125, 3404.0118.xx, UL File Number: E41599)			
	CAUTION: For continued protection against risk of fire, replace only with same type and rating of fuse.			

6.6 X7 - X8

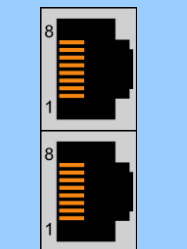
X7 - X8		RS485/CAN		
	1	RS485_Rx+	A	
	2	RS485_Rx-	B	
	3	RS485_Tx+	Y	
	4	GND		
	5	GND		
	6	RS485_Tx-	Z	
	7	CAN_H		
	8	CAN_L		
	case	Shield		
	RJ-45	Use twisted pair (1-2, 3-6, 4-5, 7-8) cable for wiring. The built in CAN and RS485 terminations can be activated by S5.2 and S5.3. X7 is internally connected to X8 (1:1 connection)		

6.7 X9

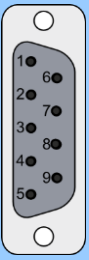
X9 PROFIBUS DP (only available on E1230-DP-UC)																															
	<table border="0"> <tr><td>1</td><td>Not connected</td><td></td></tr> <tr><td>2</td><td>Not connected</td><td></td></tr> <tr><td>3</td><td>RxD/TxD-P</td><td></td></tr> <tr><td>4</td><td>CNTR-P</td><td></td></tr> <tr><td>5</td><td>GND</td><td>(isolated)</td></tr> <tr><td>6</td><td>+5V</td><td>(isolated)</td></tr> <tr><td>7</td><td>Not connected</td><td></td></tr> <tr><td>8</td><td>RxD/TxD-N</td><td></td></tr> <tr><td>9</td><td>Not connected</td><td></td></tr> <tr><td>case</td><td>Shield</td><td></td></tr> </table>	1	Not connected		2	Not connected		3	RxD/TxD-P		4	CNTR-P		5	GND	(isolated)	6	+5V	(isolated)	7	Not connected		8	RxD/TxD-N		9	Not connected		case	Shield	
1	Not connected																														
2	Not connected																														
3	RxD/TxD-P																														
4	CNTR-P																														
5	GND	(isolated)																													
6	+5V	(isolated)																													
7	Not connected																														
8	RxD/TxD-N																														
9	Not connected																														
case	Shield																														
DSUB-9 (f)	Max. Baud rate: 12Mbaud																														

6.8 X10 - X11

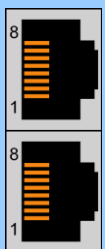
X10 - X11 Master Encoder IN (X10) / Master Encoder OUT (X11)																																											
	<table border="0"> <tr> <td></td> <td><u>Incremental:</u></td> <td><u>Step/Direction:</u></td> <td><u>EIA/TIA 568A colors:</u></td> </tr> <tr><td>1</td><td>A+</td><td>Step+</td><td>Green/White</td></tr> <tr><td>2</td><td>A-</td><td>Step-</td><td>Green</td></tr> <tr><td>3</td><td>B+</td><td>Direction+</td><td>Orange/White</td></tr> <tr><td>4</td><td>Z+</td><td>Zero+</td><td>Blue</td></tr> <tr><td>5</td><td>Z-</td><td>Zero-</td><td>Blue/White</td></tr> <tr><td>6</td><td>B-</td><td>Direction-</td><td>Orange</td></tr> <tr><td>7</td><td>CAN_H</td><td>CAN_H</td><td>Brown/White</td></tr> <tr><td>8</td><td>CAN_L</td><td>CAN_L</td><td>Brown</td></tr> <tr><td>case</td><td>Shield</td><td>Shield</td><td></td></tr> </table>		<u>Incremental:</u>	<u>Step/Direction:</u>	<u>EIA/TIA 568A colors:</u>	1	A+	Step+	Green/White	2	A-	Step-	Green	3	B+	Direction+	Orange/White	4	Z+	Zero+	Blue	5	Z-	Zero-	Blue/White	6	B-	Direction-	Orange	7	CAN_H	CAN_H	Brown/White	8	CAN_L	CAN_L	Brown	case	Shield	Shield			
	<u>Incremental:</u>	<u>Step/Direction:</u>	<u>EIA/TIA 568A colors:</u>																																								
1	A+	Step+	Green/White																																								
2	A-	Step-	Green																																								
3	B+	Direction+	Orange/White																																								
4	Z+	Zero+	Blue																																								
5	Z-	Zero-	Blue/White																																								
6	B-	Direction-	Orange																																								
7	CAN_H	CAN_H	Brown/White																																								
8	CAN_L	CAN_L	Brown																																								
case	Shield	Shield																																									
RJ-45	<p>Use twisted pair (1-2, 3-6, 4-5, 7-8) cable for wiring.</p> <p><u>Master Encoder Inputs:</u> Diff. RS422, max. counting frequency 25 Mcounts/s, quadrature evaluation, 40ns edge separation</p> <p><u>Master Encoder Outputs:</u> Amplified RS422 differential signals from Master Encoder IN (X10)</p> <p>The CAN bus can be terminated with S5.4.</p> <p>All devices, which are connected to X10/X11 must be referenced to the same ground.</p>																																										

6.9 X13

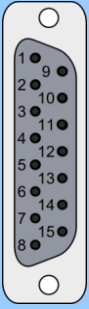
X13		External Position Sensor Differential Hall Switches		/ SSI	
		ABZ with Hall Switches		Sin/Cos 1Vpp with SSI	
	1	9	+5V DC		+5V DC
2	10	A-	A+	Sin-	Sin+
3	11	B-	B+	Cos-	Cos+
4	12	Z-	Z+	Data-	Data+
5	13	GND	Encoder Alarm	GND	Encoder Alarm
6	14	U-	U+		
7	15	V-	V+		
8		W-	W+		Clock+
case		Shield		Clock- Shield	
DSUB-15 (f)	<p><u>Position Encoder Inputs (RS422):</u> Max. counting frequency: 25 Mcounts/s with quadrature decoding, 40ns edge separation</p> <p><u>Encoder Simulation Outputs (RS422):</u> Max Output Frequency: 4 M counts/s with quadrature decoding, 250ns edge separation</p> <p><u>Differential Hall Switch Inputs (RS422):</u> Input Frequency: <1kHz</p> <p><u>Enc. Alarm In:</u> 5V / 1mA</p> <p><u>Sensor Supply:</u> 5VDC max 100mA</p>				

6.10 X15 - X16

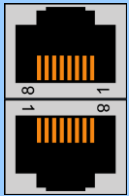
X15 - X16		Config Ethernet 10/100 Mbit/s	
 <p>X15/X16 CFG</p>	X15	Internal 2-Port 10BASE-T and 100BASE-TX Ethernet Switch with Auto MDIX. LEDs on the lower side of the device indicate "Link/Activity" per port, the upper ones are not used.	
	X16		
RJ-45			

6.11 X17 - X18

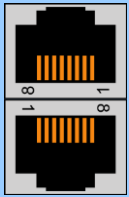
X17 - X18		RealTime Ethernet 10/100 Mbit/s
 <p>X17/X18 RT</p>	X17 RT ETH In	Specification depends on RT-Bus Type. Please refer to according documentation.
	X18 RT ETH Out	
RJ-45		

6.12 X19

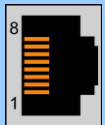
X19		System
	1	(Do not connect)
	2	(Do not connect)
	3	RS232 Rx
	4	GND
	5	GND
	6	RS232 Tx
	7	(Do not connect)
	8	(Do not connect)
	case	Shield
RJ-45	Use isolated USB-RS232 converter (Art.-No. 0150-2473) for configuration over RS232.	



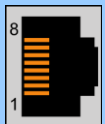

6.13 X20

X20		Analog In (+-10V Differential Analog Input)
	1	(Do not connect)
	2	(Do not connect)
	3	Analog In -
	4	GND
	5	GND
	6	Analog In +
	7	(Do not connect)
	8	(Do not connect)
	case	Shield
RJ-45		

6.14 S5

S5		Bus Termination / Analn2 Pull Down
	S5	<p>Switch 1: AnIn2 Pull down (4k7 Pull down on X4.4). Set to ON, if X4.4 is used as digital Output.</p> <p>Switch 2: Termination Resistor for RS485 on CMD (120R between pin 1 and 2 on X7/X8) on/off</p> <p>Switch 3: CAN Termination on CMD (120R between pin 7 and 8 on X7/X8) on/off</p> <p>Switch 4: CAN Termination on ME (120R between pin 7 and 8 on X10/X11) on/off</p> <p>Factory setting: all switches "off"</p>



6.15 LEDs

LEDs	State Display	
<p>Error   24VOK</p> <p>Warn   EN</p>	<p>Green</p> <p>Yellow</p> <p>Yellow</p> <p>Red</p>	<p>24V Logic Supply OK</p> <p>Motor Enabled / Error Code Low Nibble</p> <p>Warning / Error Code High Nibble</p> <p>Error</p>





6.16 RT BUS LEDs

RT Bus LEDs	RT Bus State Display	
	<p>Green</p> <p>Red</p>	<p>OK</p> <p>Error</p>
<p>The use of these LEDs depends on the type of fieldbus which is used. Please see the corresponding manual for further information.</p>		

6.17 S1 - S2

S1 - S2	Address Selectors	
	S1 (5..8)	Bus ID High (0 ... F). Bit 5 is LSB, bit 8 MSB.
	S2 (1..4)	Bus ID Low (0 ... F). Bit 1 is LSB, bit 4 MSB.
<p>The use of these switches depends on the type of fieldbus which is used. Please see the corresponding manual for further information.</p>		

7 Error Codes

Error Codes			
<div style="text-align: center;"> Error   24VOK Warn   EN </div>			
Error	Warn	EN	Description
Off	Warning	Operation Enabled	Normal Operation: Warnings and operation enabled are displayed.
On	<ul style="list-style-type: none"> • ~2Hz 0..15 x Error Code High Nibble 	<ul style="list-style-type: none"> • ~2Hz 0..15 x Error Code Low Nibble 	Error: The error code is shown by a blink code with "WARN" and "EN". The error byte is divided into low and high nibble (= 4 bit). "WARN" and "EN" are blinking together. The error can be acknowledged. (e.g.: WARN blinks 3x, EN blinks 2x; Error Code = 32h)
<ul style="list-style-type: none"> • ~2Hz 	<ul style="list-style-type: none"> • ~2Hz 0..15 x Error Code High Nibble 	<ul style="list-style-type: none"> • ~2Hz 0..15 x Error Code Low Nibble 	Fatal Error: The error code is shown by a blink code with "WARN" and "EN". The error byte is divided into low and high nibble. "WARN" and "EN" are blinking together. Fatal errors can only be acknowledged by a reset or power cycle. (e.g.: WARN blinks 3x, EN blinks 2x; Error Code = 32h)
<ul style="list-style-type: none"> • ~4Hz 	<ul style="list-style-type: none"> • ~2Hz 0..15 x Error Code High Nibble 	<ul style="list-style-type: none"> • ~2Hz 0..15 x Error Code Low Nibble 	System Error: Please reinstall firmware or contact support.
<ul style="list-style-type: none"> • ~0.5Hz 	<ul style="list-style-type: none"> • ~0.5Hz 	On	Signal Supply 24V too low: The error and warn LEDs blink alternating if the signal supply +24V (X4.2) is less than 18VDC.
Off	*•••	••••	Plug&Play Communication Active This sequence (Warn on, then En on, then both off, complete sequence of the 4 states ca. 1Sec) signalizes the state when the plug and play parameters are being read from the motor.
<ul style="list-style-type: none"> *• ~4Hz 	<ul style="list-style-type: none"> •* ~4Hz 	off	Waiting for Defaulting Parameters When ID (S1, S2) is set to 0xFF, the drive starts up in a special mode and the Error and Warn LED blink alternating ~4Hz. When the ID is set to 0x00, all parameters will be set to their default value. To leave this state, power down the drive and change the ID. Also see in the Usermanual_LinMot-Talk under chapter trouble shooting.
Off	<ul style="list-style-type: none"> *• ~2Hz 	<ul style="list-style-type: none"> *• ~2Hz 	Defaulting Parameters Done When the parameters have set to their default values (initiated via S1/S2 on power up) the Warn and En LEDs blink together at 2 Hz. To leave this state, power down the drive. Also see in the Usermanual_LinMot-Talk under chapter trouble shooting.

The meaning of the error codes can be found in the Usermanual_MotionCtrlSW_SG5 and the user manual of the installed interface software. These documents are provided together with LinMot-Talk configuration software and can be downloaded from www.linmot.com.

8 Physical Dimensions

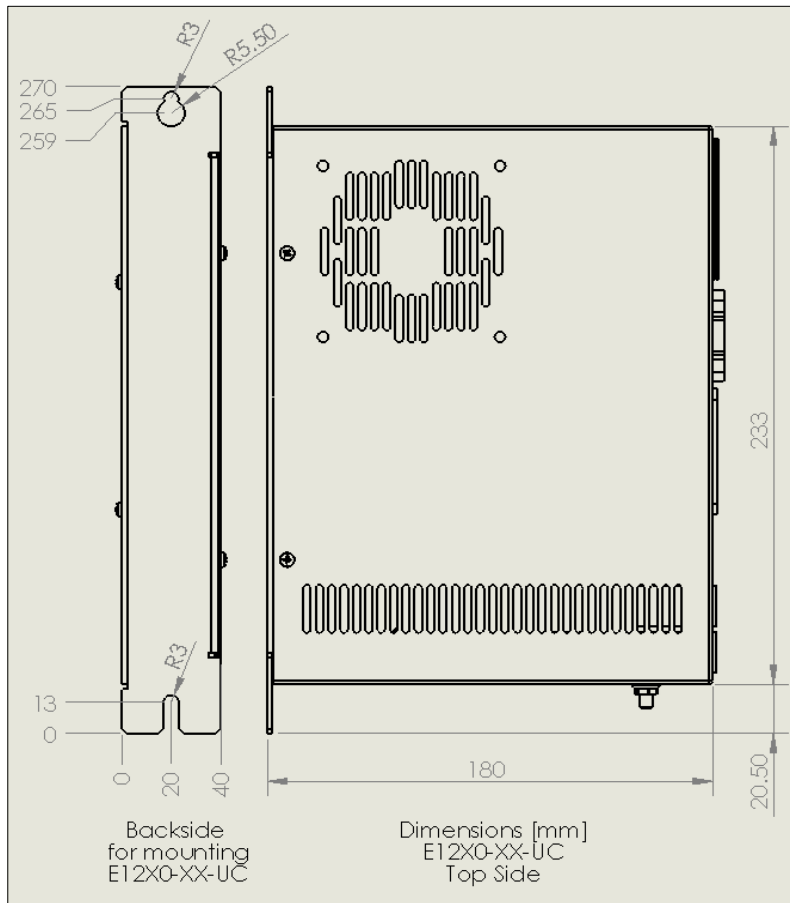

E1200 Series single axis drive		
Width	mm (in)	40 (1.6)
Height	mm (in)	233 (9.2)
Height with fixings	mm (in)	270 (10.7)
Depth	mm (in)	180 (7.1)
Weight	kg (lb)	1.5 (3.3)
Case	IP	20
Mounting Screws		2 x M5
Mounting Distance	mm (in)	252 (9.92)
Storage Temperature	°C	-25...40
Transport Temperature	°C	-25...70
Operating Temperature	°C	0...40 at rated data 40...50 with power derating
Relative humidity		95% (non-condensing)
Max. Case Temperature	°C	65
Max. Power Dissipation	W	30
Clearance around drives	mm (in)	20 (0.8) left/right 50 (2) top / bottom

9 Power Supply Requirements

Motor Power Supply

The calculation of the needed power for the Motor supply is depending on the application and the used motor. The nominal supply voltage is 72- 80 VDC. The possible range is from 24 to 85VDC.



ATTENTION: The motor supply can rise up to 95 VDC when braking. This means that everything connected to that power supply needs a voltage rating of 100 VDC. (Additional capacitors, etc...). Due to high braking voltage and sudden load variations of linear motor applications, **only specially designed power supplies can be used.**

Compatible Power supplies:

Item	Description	Art. No.
T01-72/420	72VDC, 15A peak, 420VA, 3x400VAC	0150-1966
T01-72/420-US	72VDC, 15A peak, 420VA, 3x230VAC	0150-1967
T01-72/900	72VDC, 30A peak, 900VA, 3x400VAC	0150-1842
T01-72/900-US	72VDC, 30A peak, 900VA, 3x230VAC	0150-1843
T01-72/1500	72VDC, 2x30A peak, 1500VA, 3x400VAC	0150-1844
T01-72/1500-US	72VDC, 2x30A peak, 1500VA, 3x230VAC	0150-1845
S01-72/500	72VDC, 500W, 750W peak, 1x100..120VAC/200..240VAC	0150-1874
S01-72/1000	72VDC, 1000W, 2000W peak, 3x380..500VAC	0150-1872

For compatibility with other power supplies, contact support@linmot.com

Signal Power Supply

The logic supply needs a regulated power supply of a nominal voltage of 24 VDC. The voltage must be between 22 and 26 VDC.

Current consumption:

min. 200mA (no load on the outputs)

typ. 1.1A (all 10 outputs "on" with 100mA load and /Brake with no load)

max. 2.1A (all 10 outputs "on" with 100mA load and /Brake with 1A load)

10 Regeneration of Power / Regeneration Resistor

There are two possibilities to deal with power regeneration:



- Option A: Connect an additional capacitor to the motor power supply. It is recommended to use a capacitor $\geq 10'000 \mu\text{F}$ (install capacitor close to the power supply!)
- Option B: Install a regeneration resistor to X1 (RR+ and RR-). The threshold value of the voltage depends on the used motor voltage power supply. The max. threshold value must not exceed 88 VDC.

Item	Description	Art. No.
Capacitor	Capacitor 10'000 μF / 100 V	0150-3075
Regeneration Resistor	R01-10/60 (10 Ohm, 60 W)	0150-3088
Regeneration Resistor	RR01-10/150 (10 Ohm, 150 W)	0150-3090

11 Ordering Information

Item	Description	Art. No.
E1250-PL-UC	POWERLINK Servo Drive 72VDC/32A	0150-1760
E1250-PN-UC	PROFINET Servo Drive 72VDC/32A	0150-1762
E1250-PD-UC	ProfiDrive Servo Drive 72VDC/32A	0150-2620
E1250-EC-UC	EtherCAT Servo Drive 72VDC/32A	0150-1763
E1250-SE-UC	sercos over EtherCAT Servo Drive 72VDC/32A	0150-1898
E1250-DS-UC	EtherCAT CoE Servo Drive 72VDC/32A	0150-2410
E1250-SC-UC	sercos Servo Drive 72VDC/32A	0150-1764
E1250-IP-UC	ETHERNET IP Servo Drive 72VDC/32A	0150-1761
E1250-LU-UC	LinUDP Servo Drive 72VDC/32A	0150-2493
E1230-DP-UC	PROFIBUS-DP Servo Drive 72VDC/32A	0150-1766
E1200-GP-UC	GENERAL PURPOSE Servo Drive 72VDC/32A	0150-1771
Accessories	Description	Art. No.
Isolated USB-RS232 converter	Isolated USB RS232 converter with config. cable	0150-2473
Connector for X4	Connector MC 1,5/12-STF-3,5, delivered with drive	0150-3300
RS232 PC config. Cable 2.5m	For C1100/C1250/E1200/E1400/M8000	0150-2143
Isolated USB-serial converter	Isolated USB RS232/422/485 converter	0150-3120

12 International Certifications

Certifications	
Europe 	See chapter “13 EU Declaration of Conformity CE-Marking“
UK 	See chapter 15 UK Declaration of Conformity UKCA-Marking



Declaration of Conformity to the EtherNet/IP™ Specification

ODVA hereby issues this Declaration of Conformity to *The EtherNet/IP™ Specification* for the product(s) described below. The Vendor listed below (the "Vendor") holds a valid Terms of Usage Agreement, which is incorporated herein by reference, for the EtherNet/IP Technology from ODVA, thereby agreeing that it is the Vendor's ultimate responsibility to assure that its EtherNet/IP Compliant Products conform to *The EtherNet/IP Specification* and that *The EtherNet/IP Specification* is provided by ODVA to the Vendor on an AS IS basis without warranty. NO WARRANTIES, EXPRESSED OR IMPLIED, INCLUDING WITHOUT LIMITATION ANY WARRANTIES OF MERCHANTABILITY OR FITNESS FOR A PARTICULAR PURPOSE, ARE BEING PROVIDED BY ODVA.

In recognition of the below EtherNet/IP Compliant Product(s) having been EtherNet/IP Conformance Tested at ODVA-authorized Test Service Provider and having received a passing result from ODVA at the Composite Test Revision Level specified below, this Declaration of Conformity authorizes the Vendor to use the EtherNet/IP Certification Marks in conjunction with the specific EtherNet/IP Compliant Product(s) described below, for so long as the Vendor's Terms of Usage Agreement for the EtherNet/IP Technology remains valid.



Certification Logo Mark

EtherNet/IP CONFORMANCE TESTED™

Certification Word Mark

This Declaration of Conformity is issued on February 2, 2015 on behalf of ODVA by:

Katherine Voss
Executive Director

Vendor Information				
Vendor Name	NTI Limited			
Test Information				
Test Date	December 11, 2014			
Composite Test Revision	CT11			
ODVA File Number	11332.01			
Product Information		Network Category:	Node	
Identity Object Instance				
Vendor ID (Attribute 1)	589			
Device Type (Attribute 2)	0x2B			
Device Profile Name	Generic Device (keyable)			
Products Covered under this Declaration of Conformity (Identity Object Instance)				
No.	Product Code (Attribute 3)	Product Name (Attribute 7)	Product Revision (Attribute 4)	SOC File Name
1	1886	C1250IPXC0S	1.001	C1250IPXC0S.stc
2	2346	C1250IPXC1S	1.001	C1250IPXC1S.stc
3	1761	E1250-IP-UC	1.001	Not Tested
4	1782	E1450IPQN0S	1.001	Not Tested
5	2354	E1450IPQN1S	1.001	Not Tested
6	2610	C1450IPQN0S	1.001	Not Tested
7	2611	C1450IPQN1S	1.001	Not Tested
8	2612	C1450IPQD0S	1.001	Not Tested
9	2613	D1450IPVR0S	1.001	Not Tested
10	2614	D1450IPQD0S	1.001	Not Tested
11	2615	D1250IPXC0S	1.001	Not Tested

EtherNet/IP and EtherNet/IP CONFORMANCE TESTED logo mark and word mark are trademarks of ODVA, Inc.

Copyright © ODVA, Inc. 2004-2013

PUB00033R7

www.odva.org

Page 1 of 1

13 EU Declaration of Conformity CE-Marking

NTI AG / LinMot®
Bodenaeckerstrasse 2
8957 Spreitenbach
Switzerland
Tel.: +41 (0)56 419 91 91
Fax: +41 (0)56 419 91 92

declares under sole responsibility the compliance of the products:
- **Drives of the Series E12xx-xx-xx**

with the **EMC Directive 2014/30/EU**.

Applied harmonized standards:

- **EN 61000-6-2: 2005 (Immunity for industrial environments)**
- **EN 61000-6-4: 2007 +A1:2011 (Emission for industrial environments)**

According to the EMC directive, the listed devices are not independently operable products.

Compliance of the directive requires the correct installation of the product, the observance of specific installation guides and product documentation. This was tested on specific system configurations.

The safety instructions of the manuals are to be considered.

These products are intended for installation in machines. Operation is prohibited until it has been determined that the machines in which these products are to be installed, conforms to the above-mentioned EC directive.

The product must be mounted and used in strict accordance with the installation instructions contained within the installation guide, a copy of which may be obtained from NTI AG.

Company: NTI AG
Spreitenbach, 11.04.2016



Dr. Ronald Rohner / CEO NTI AG

14 UK Declaration of Conformity UKCA-Marking

NTI AG / LinMot®
Bodenaeckerstrasse 2
8957 Spreitenbach
Switzerland
Tel.: +41 (0)56 419 91 91
Fax: +41 (0)56 419 91 92

declares under sole responsibility the compliance of the products:

- Drives of the Series **E12xx-xx-xx**

with the EMC Regulation S.I. 2016 No. 1091.

Applied designated standards:

- EN 61000-6-2: 2005 (Immunity for industrial environments)
- EN 61000-6-4: 2007 + A1:2011 (Emission for industrial environments)

According to the EMC regulation, the listed devices are not independently operable products.

Compliance of the regulation requires the correct installation of the product, the observance of specific installation guides and product documentation. This was tested on specific system configurations.

The safety instructions of the manuals are to be considered.

The product must be mounted and used in strict accordance with the installation instructions contained within the installation guide, a copy of which may be obtained from NTI AG.

Company: NTI AG
Spreitenbach, 23.03.2022



Dr. Ronald Rohner / CEO NTI AG

15 Contact Addresses**SWITZERLAND****NTI AG**

Bodenaeckerstrasse 2
CH-8957 Spreitenbach

Sales and Administration:

+41-(0)56-419 91 91
office@linmot.com

Tech. Support:

+41-(0)56-544 71 00
support@linmot.com

Tech. Support (Skype) :

skype:support.linmot

Fax:

+41-(0)56-419 91 92

Web:

<http://www.linmot.com/>

USA**LinMot USA Inc.**

N1922 State Road 120, Unit 1
Lake Geneva, WI 53147
USA

Phone

262-743-2555

E-Mail:

usasales@linmot.com

Web:

<http://www.linmot-usa.com/>

Please visit <http://www.linmot.com/> to find the distributor closest to you.

Smart solutions are...

