

## C1250 Servo Drives

---

Installation Guide

[\(For the C1250-MI drives see IG 0185-1175-E ...\)](#)



Please visit <http://www.linmot.com> to check for the latest version of this document!

© 2024 NTI AG

This work is protected by copyright.

Under the copyright laws, this publication may not be reproduced or transmitted in any form, electronic or mechanical, including photocopying, recording, microfilm, storing in an information retrieval system, not even for didactical use, or translating, in whole or in part, without the prior written consent of NTI AG.

*LinMot*<sup>®</sup> is a registered trademark of NTI AG.

#### Note

The information in this documentation reflects the stage of development at the time of press and is therefore without obligation. NTI AG reserves itself the right to make changes at any time and without notice to reflect further technical advance or product improvement.

NTI AG  
LinMot<sup>®</sup>  
Bodenaeckerstrasse 2  
CH-8957 Spreitenbach

Tel.: +41 (0)56 419 91 91  
Fax: +41 (0)56 419 91 92  
Email: [office@LinMot.com](mailto:office@LinMot.com)  
Homepage: [www.LinMot.com](http://www.LinMot.com)

**Table of Contents**

**Table of Contents** ..... 3

**1 Important Safety Instructions** ..... 4

**2 System Overview**..... 6

**3 Interfaces** ..... 7

**4 Labels on the drive**..... 8

**5 Functionality** ..... 9

**6 Software** ..... 10

**7 Power Supply and Grounding**..... 10

**8 Calibrated Measuring Amplifier (C1250-xx-XC-xS-Cxx)** ..... 11

**9 Description of the connectors / Interfaces** ..... 11

    9.1 PE ..... 11

    9.2 X1 ..... 11

    9.3 X2/X3 Motor Connection ..... 12

    9.4 X4 ..... 13

    9.5 X13 ..... 13

    9.6 X17 – X18 ..... 14

    9.7 X19 ..... 14

    9.8 X33 ..... 14

    9.9 S1 – S2 ..... 14

    9.10 S5 ..... 15

    9.11 LEDs ..... 15

    9.12 RT Bus LEDs ..... 15

**10 LED Blink Codes** ..... 16

**11 Safety Wiring**..... 17

**12 Physical Dimension** ..... 19

**13 Power Supply Requirements** ..... 20

    13.1 Motor Power Supply ..... 20

    13.2 Signal Power Supply ..... 20

**14 Regeneration** ..... 20

**15 Safety notes for the installation according UL** ..... 21

**16 Ordering Information** ..... 22

**17 International Certifications**..... 24

**18 EU Declaration of Conformity CE-Marking** ..... 31

**19 UK Declaration of Conformity UKCA-Marking** ..... 32

**20 Contact & Support**..... 33

## 1 Important Safety Instructions



### For your personal safety

Disregarding the following safety measures can lead to severe injury to persons and damage to material:

- Only use the product as directed.
- Never commission the product in the event of visible damage.
- Never commission the product before assembly has been completed.
- Do not carry out any technical changes on the product.
- Only use the accessories approved for the product.
- Only use original spare parts from LinMot.
- Observe all regulations for the prevention of accidents, directives and laws applicable on site.
- Transport, installation, commissioning and maintenance work must only be carried out by qualified personnel.
  - Observe IEC 364 and CENELEC HD 384 or DIN VDE 0100 and IEC report 664 or DIN VDE 0110 and all national regulations for the prevention of accidents.
  - According to the basic safety information, qualified, skilled personnel are persons who are familiar with the assembly, installation, commissioning, and operation of the product and who have the qualifications necessary for their occupation.
- Observe all specifications in this documentation.
  - This is the condition for safe and trouble-free operation and the achievement of the specified product features.
  - The procedural notes and circuit details described in this documentation are only proposals. It is up to the user to check whether they can be transferred to the particular applications. NTI AG / LinMot does not accept any liability for the suitability of the procedures and circuit proposals described.
- LinMot servo drives and the accessory components can include live and moving parts (depending on their type of protection) during operation. Surfaces can be hot.
  - Non-authorized removal of the required cover, inappropriate use, incorrect installation or operation create the risk of severe injury to persons or damage to material assets.
  - For more information, please see the documentation.
- High amounts of energy are produced in the drive. Therefore, it is required to wear personal protective equipment (body protection, headgear, eye protection, hand guard).

### Application as directed

- Drives are components, which are designed for installation in electrical systems or machines. They are not to be used as domestic appliances, but only for industrial purposes according to EN 61000-3-2.
- When drives are installed into machines, commissioning (i.e. starting of the operation as directed) is prohibited until it is proven that the machine complies with the regulations of the EC Directive 2006/42/EG (Machinery Directive); EN 60204 must be observed.
- Commissioning (i.e. starting of the operation as directed) is only allowed when there is compliance with the EMC Directive (2014/30/EU).
- The technical data and supply conditions can be obtained from the nameplate and the documentation. They must be strictly observed.

### Transport, storage

- Please observe the notes on transport, storage, and appropriate handling.
- Observe the climatic conditions according to the technical data.

## Installation

- The drives must be installed and cooled according to the instructions given in the corresponding documentation.
- The ambient air must not exceed degree of pollution 2 according to EN 61800-5-1.
- Ensure proper handling and avoid excessive mechanical stress. Do not bend any components and do not change any insulation distances during transport or handling. Do not touch any electronic components and contacts.
- Drives contain electrostatic sensitive devices, which can easily be damaged by inappropriate handling. Do not damage or destroy any electrical components since this might endanger your health!

## Electrical connection



When working on live drives, observe the applicable national regulations for the prevention of accidents.

The electrical installation must be carried out according to the appropriate regulations (e.g. cable cross-sections, circuit breakers, fuses, PE connection). Additional information can be obtained from the documentation.

This product can cause high-frequency interferences in non-industrial environments, which can require measures for interference suppression.

## Operation

- If necessary, systems including drives must be equipped with additional monitoring and protection devices according to the valid safety regulations (e.g. law on technical equipment, regulations for the prevention of accidents). The drives can be adapted to your application. Please observe the corresponding information given in the documentation.
- After the drive has been disconnected from the supply voltage, all live components and power connections must not be touched immediately because capacitors can still be charged. Please observe the corresponding stickers on the drive. All protection covers and doors must be shut during operation.

## Protection of persons



The power terminals Ph1+, Ph1-, Ph2+, Ph2- and PWR+ remain live for at least 5 minutes after disconnecting from the power supplies.

Before servicing, disconnect supply, wait 5 minutes and measure between PWR+ and PGND to be sure that the capacitors have discharged below 42 VDC.



The heat sink (housing) of the drive can have an operating temperature of > 80 °C: Contact with the heat sink results in burns.

### 2 System Overview

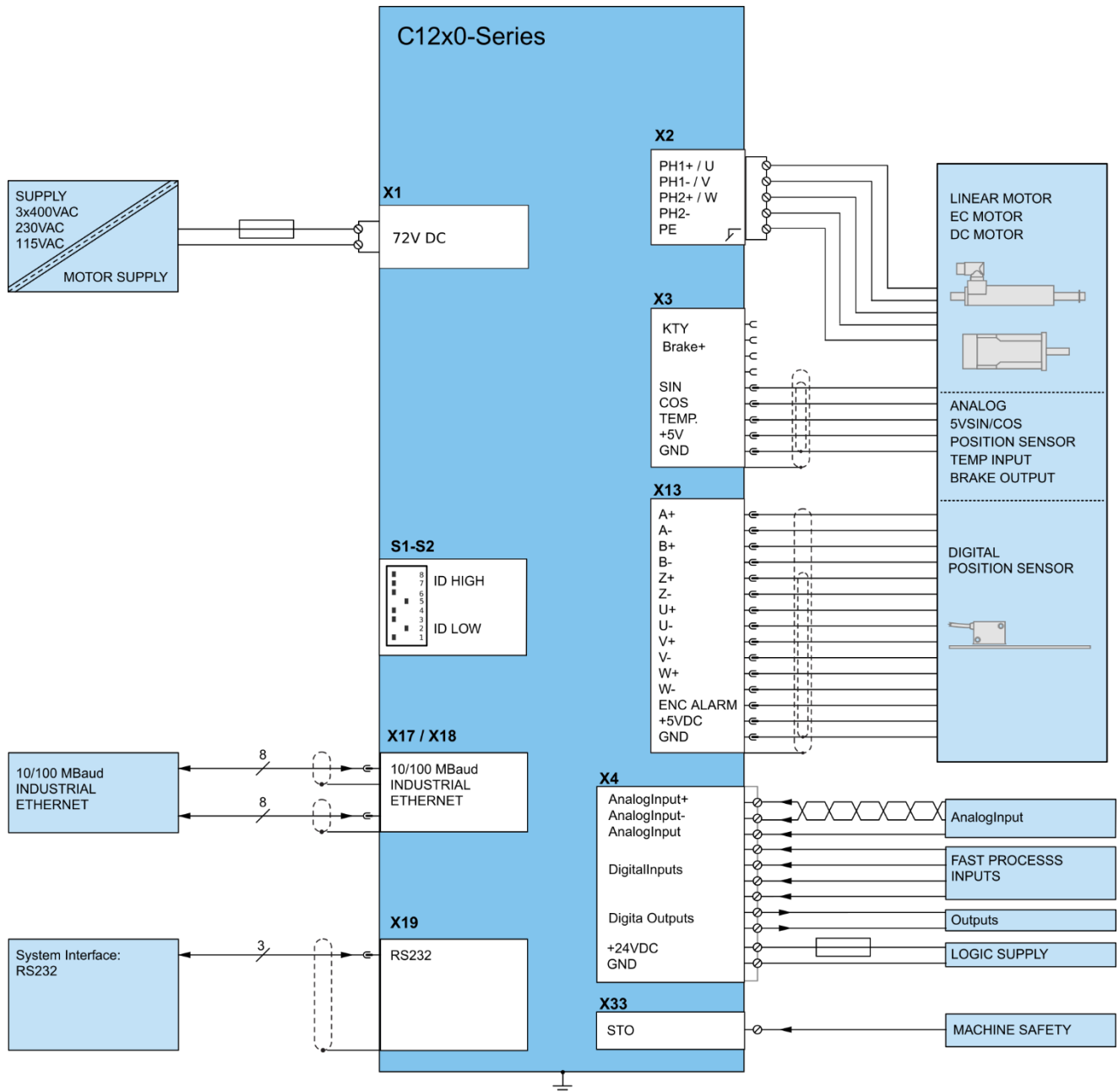

Figure 1: Typical servo system C1250: Servo drive, motor and power supply

3 Interfaces

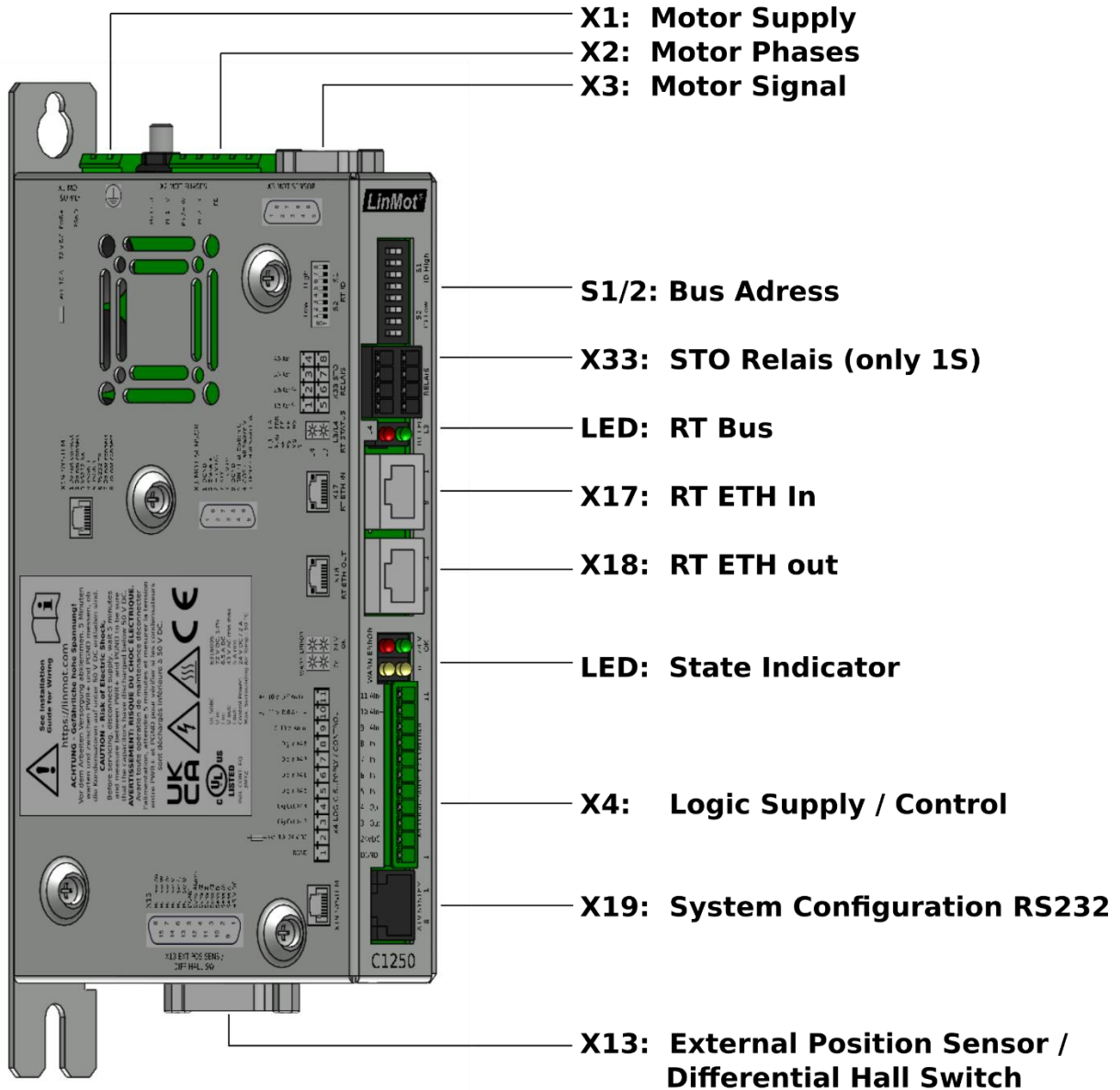

Figure 2: C1250-xx-XC-xS-xxx

### 4 Labels on the drive

There are two labels on the side of the drive. On the “LinMot” label the drive type, part number and serial number can be found. On the “UL” label there is UL information and the production type. The production type is not relevant for the end user. It is only used during production.

**LinMot<sup>(R)</sup>** PnP

Type:	C1250-IP-XC-1S-C00
Part No.:	0150-4128
Serial No.:	4128.85A.027
Hardware:	Ver. 1 Rev. H4
Signal Sup.:	24 VDC
Power Sup.:	24-85 VDC

MAC-IDs: 00:1A:4E:04:55:68/69

 NTI AG, LinMot  
Bodenaeckerstrasse 2  
CH-8957 Spreitenbach  
<http://www.linmot.com>



**UL** **US LISTED**

IND. CONT. EQ.  
3MYZ  
UL File E316095 C

U in:	72 VDC, 1-Ph
I in:	6.5 A
U out:	43 VAC rms max
I out:	5 A rms
Control Power:	24 VDC / 2 A

Max. Surrounding Air Temp.: 50 °C  
Please refer to installation guide!

CP1250-PN-XC-1S-000  
Ver. 1 Rev. H4  
2471.85A.027



LinMot Type, part- and serial number and HW version and revision

“Production type”, not relevant and may differ from LinMot Type

QR code, containing serial number, HW version and revision and the MAC-IDs.



## 5 Functionality

	C1250-PL-XC-0S	C1250-PN-XC-0S	C1250-PD-XC-0S	C1250-SC-XC-0S	C1250-IP-XC-0S	C1250-LU-XC-0S	C1250-EC-XC-0S	C1250-DS-XC-0S	C1250-SE-XC-0S	C1250-CM-XC-0S	C1250-CC-XC-0S	C1250-PL-XC-1S	C1250-PN-XC-1S	C1250-PD-XC-1S	C1250-SC-XC-1S	C1250-IP-XC-1S	C1250-LU-XC-1S	C1250-EC-XC-1S	C1250-DS-XC-1S	C1250-SE-XC-1S	C1250-CM-XC-1S	C1250-CC-XC-1S
<b>Supply Voltage</b>																						
Motor Supply 72 VDC (24..85 VDC)	•	•	•	•	•	•	•	•	•	•	•	•	•	•	•	•	•	•	•	•	•	•
Logic Supply 24 VDC (22...26 VDC)	•	•	•	•	•	•	•	•	•	•	•	•	•	•	•	•	•	•	•	•	•	•
<b>Motor Phase Current</b>																						
25 A peak (0-599 Hz)	•	•	•	•	•	•	•	•	•	•	•	•	•	•	•	•	•	•	•	•	•	•
<b>Controllable Motors</b>																						
LinMot P0x- and PR0x-Motors	•	•	•	•	•	•	•	•	•	•	•	•	•	•	•	•	•	•	•	•	•	•
Selected motors (contact support)	•	•	•	•	•	•	•	•	•	•	•	•	•	•	•	•	•	•	•	•	•	•
Plug and Play (PnP) Auto Configuration	•	•	•	•	•	•	•	•	•	•	•	•	•	•	•	•	•	•	•	•	•	•
<b>Command Interface</b>																						
POWERLINK	•											•										
PROFINET		•											•									
PROFINET PROFIdrive			•											•								
Sercos III				•											•							
EtherNet/IP					•											•						
LinUDP						•											•					
EtherCAT							•											•				
EtherCAT CiA402								•											•			
EtherCAT SoE									•											•		
EtherNet/IP CIP Sync										•											•	
CC-Link											•											•
<b>Programmable Motion Profiles (Curves)</b>																						
Up to 100 Motion Profiles	•	•	•	•	•	•	•	•	•	•	•	•	•	•	•	•	•	•	•	•	•	•
Up to 16302 Curve Points	•	•	•	•	•	•	•	•	•	•	•	•	•	•	•	•	•	•	•	•	•	•
<b>Programmable Command Table</b>																						
Command Table with up to 255 entries	•	•	•	•	•	•	•	•	•	•	•	•	•	•	•	•	•	•	•	•	•	•
<b>External Position Sensor</b>																						
Incremental (RS422 up to 25 Mcounts/s)	•	•	•	•	•	•	•	•	•	•	•	•	•	•	•	•	•	•	•	•	•	•
Absolute (SSI, BiSS-B*, BiSS-C*, EnDat2.1**, EnDat 2.2**)	•	•	•	•	•	•	•	•	•	•	•	•	•	•	•	•	•	•	•	•	•	•
<b>Configuration Interface</b>																						
RS232	•	•	•	•	•	•	•	•	•	•	•	•	•	•	•	•	•	•	•	•	•	•
Ethernet (EoE, etc... depending on Interface)	•	•	•	•	•	•	•	•	•	•	•	•	•	•	•	•	•	•	•	•	•	•
<b>Integrated Safety Functions (-1S Option)</b>																						
STO (2 Safety Relays)												•	•	•	•	•	•	•	•	•	•	•
<b>Calibrated Measuring Functions (-Cxx Option)</b>																						
	•	•	•	•	•	•	•	•	•	•	•	•	•	•	•	•	•	•	•	•	•	•

\* since firmware version 6.6  
 \*\* since firmware version 6.7  
 \*\*\* only with the C1250-xx-XC-xS-Cxx type

### 6 Software

The configuration software LinMot-Talk is free of charge and can be downloaded from the LinMot homepage.

### 7 Power Supply and Grounding

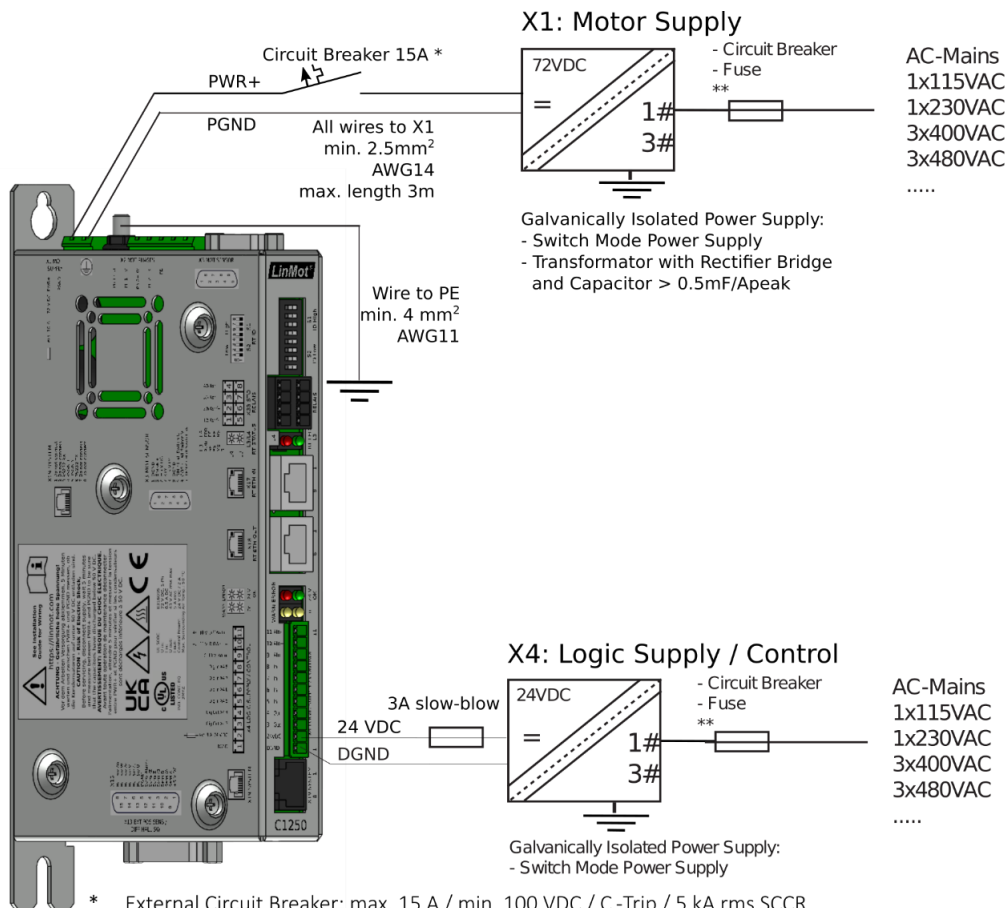

In order to assure a safe and error free operation, and to avoid severe damage to system components, **all system components must be well grounded to protective earth PE**. This includes both LinMot and all other control system components on the same ground bus.



Each system component<sup>1</sup> should be tied directly to the ground bus (**star pattern**). Daisy chaining from component to component is forbidden. (LinMot motors are properly grounded through their power cables when connected to LinMot drives.)



**Power supply connectors must not be connected or disconnected while DC voltage is present.** Do not disconnect system components until all LinMot drive LEDs have turned off. (Capacitors in the power supply may not fully discharge for several minutes after input voltage has been disconnected). Failure to observe these precautions may result in severe damage to electronic components in LinMot motors and/or drives.



**Do not switch Power Supply DC Voltage.** All power supply switching and E-Stop breaks should be done to the AC supply voltage of the power supply. Failure to observe these precautions may result in severe damage to the drive.

<sup>1</sup> Inside of the C1250 drive the PWR motor GND and PWR signal GND is connected together and to the GND of the drive housing. It is recommended that the PWR motor GND is NOT grounded at another place than inside of the drive to reduce circular currents.

## 8 Calibrated Measuring Amplifier (C1250-xx-XC-xS-Cxx)

The drives with the ending -Cxx are specially designed for measuring applications. They come with a factory calibration certificate for the analog inputs on X4. The analog inputs on X4 provide a measuring error of less than 1%.

These drives have at least hardware version 1 revision H4 (V1RH4) and therefore come as well with an UL listing.

The firmware must be at least version 6.9.

It is the user's responsibility to allow a reasonable period for recalibration. We recommend a calibration interval of 12 months.

## 9 Description of the connectors / Interfaces

### 9.1 PE

PE	Protective Earth
	<ul style="list-style-type: none"> <li>• Use min. 4 mm<sup>2</sup> (AWG11)</li> <li>• Tightening torque: 2 Nm (18 lbin)</li> </ul>

### 9.2 X1

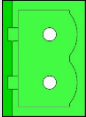
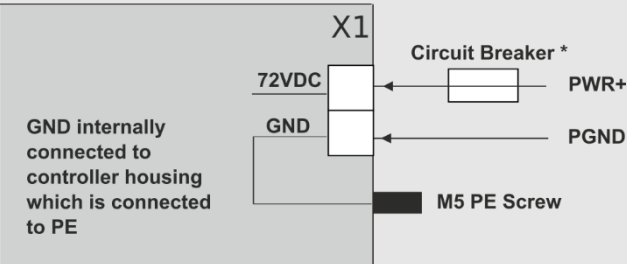
X1	Motor Supply	
	<p>PWR+</p> <p>PGND</p>	 <p>GND internally connected to controller housing which is connected to PE</p>
<p>Connector has to be ordered separately: see chapter 16)</p>	<p>Motor Supply: 72 VDC nominal (24...85 VDC)                      Absolute max. Rating: 72 VDC +20%.                      External Circuit Breaker: 15 A / min. 100 VDC / C-Trip / 5 kA rms SCCR</p> <p>If motor supply voltage exceeds 90 VDC, the drive will go into error state.</p> <ul style="list-style-type: none"> <li>• Use 60/75 °C copper conductors only</li> <li>• Conductor Cross-Section 2.5 mm<sup>2</sup> (AWG14) max Length 3 m</li> </ul>	

### 9.3 X2/X3 Motor Connection

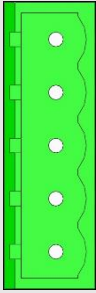
X2	Motor Phases		
	PH1+	<b>LinMot Motor:</b> Motor Phase 1+ red	<b>3-phase EC-Motor:</b> Motor Phase U red
	PH1	Motor Phase 1- pink	Motor Phase V pink
	PH2+	Motor Phase 2+ blue	Motor Phase W blue
	PH2-	Motor Phase 2- grey	Motor Phase X grey
	PE/SCRN	PE	PE
Connector has to be ordered separately: see chapter 16)	<ul style="list-style-type: none"> <li>Use 60/75 °C copper conductors only</li> <li>Conductor cross-section: 0.5 – 2.5 mm<sup>2</sup> (depends on Motor current) / AWG 21 -14</li> </ul>		

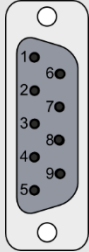
X3	Motor Sensor / Brake		
	1	<b>LinMot Motor:</b> Do not connect	<b>EC Motor:</b> DGND, (Do not connect before Ver.1Rev.H4)
	6	Do not connect	Brake+
	2	Do not connect	+5 VDC, (Do not connect before Ver.1Rev.H4)
	7	Do not connect	KTY
	3	+5 VDC	+5 VDC
	8	DGND	DGND
4	Sensor Sine	Sensor Sine / Hall Switch U	
9	Sensor Cosine	Sensor Cosine / Hall Switch V	
5	Temp In	Hall Switch W	
case	Shield	Shield	
DSUB-9 (f)	<p><b>Note:</b></p> <ul style="list-style-type: none"> <li>Use +5 VDC (X3.3) and DGND (X3.8) only for motor internal hall sensor supply (max. 100 mA).</li> <li>Max. motor cable length: 50m for LinMot Px motors. Please check restrictions of motor, encoder and cable as well.</li> <li>Brake+: 24 V / max. 500 mA, peak 1.4 A (will shut down if exceeded) the other terminal has to be wired to DGND (X3.1) (Since Ver.1Rev.H4)</li> </ul> <p><b>Caution:</b></p> <ul style="list-style-type: none"> <li>Do NOT connect DGND (X3.8) to ground or earth!</li> </ul> <p><b>Temperature Sensor:</b></p> <ul style="list-style-type: none"> <li>A resistive temperature sensor (PT1000, KTY) could be connected between +5 VDC (X3.2) and KTY (X3.7)</li> </ul>		

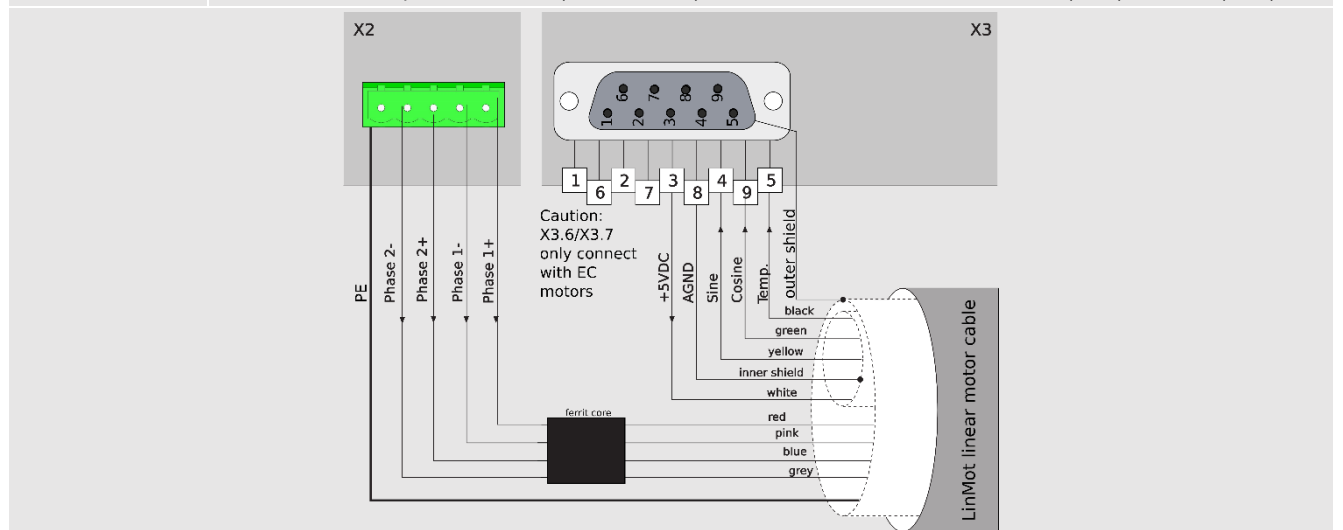

**Important Notes:**

- Use Y-style motor cables only (for example K15-Y/C)! A W-style cable has a different shielding, so it cannot be modified to a Y-style cable!

## 9.4 X4

X4	Logic Supply / IO Connection			
	11	AnIn-	X4.11	Configurable differential analog Input (with X4.10)
	10	AnIn+	X4.10	Configurable differential analog Input (with X4.11)
	9	AnIn	X4.9	Configurable single ended analog Input
	8	In	X4.8	Configurable digital Input
	7	In	X4.7	Configurable digital Input
	6	In	X4.6	Configurable digital Input
	5	In	X4.5	Configurable digital Input
	4	Out	X4.4	Configurable digital Output
	3	Out	X4.3	Configurable digital Output
	2	+24VDC Supply		Logic Supply 22-26 VDC
	1	DGND Supply		Ground
<p>Spring cage connector (has to be ordered separately: see chapter 16)</p>	<p><b>Digital inputs</b> (X4.5 ... X4.8): 24 VDC / 5 mA (Low Level: -0.5 to 5 VDC, High Level: 15 to 30 VDC)</p> <p><b>Digital outputs</b> (X4.3 &amp; X4.4): 24 VDC / max. 500 mA, peak 1.4 A (will shut down if exceeded)</p> <p>X4.3: Can be used as brake output for LinMot motors</p> <p>Both outputs are high-side switching with integrated pull-down (1k7 to DGND)</p> <p><b>Analog inputs:</b> 12 bit A/D converted</p> <p>until V1RH3: X4.9: 0..10 V, input resistance: &gt;90 kΩ to DGND</p> <p>X4.10/X4.11: +/- 10 V, input resistance 20.0 kΩ, common mode range: -5..+5 V to DGND</p> <p>since V1RH4: X4.9: 0..10 V, input resistance: &gt;75 kΩ to DGND</p> <p>X4.10/X4.11: +/- 10 V, input resistance 28.0 kΩ, common mode range: -5..+10 V to DGND,</p> <p><b>Mating connector (Art. Nr. 0150-3447):</b></p> <ul style="list-style-type: none"> <li>• Use 60/75 °C copper conductors only</li> <li>• Conductor cross-section max. 1.5 mm<sup>2</sup></li> <li>• Stripping length: 11.5 mm</li> </ul> <p><b>Important notes:</b></p> <p>The 24 VDC logic supply for the control circuit (X4.2) must be protected with an external fuse (3 A slow blow)</p>			

## 9.5 X13

X13	External Position Sensor Differential Hall Switches		
	1	<b>ABZ with Hall Switches</b>	
			+5V DC
	9	A+	SSI / BiSS-B* / BiSS-C* / EnDat2.1** / EnDat2.2**
	2	A-	A+ (optional)
	10	B+	A- (optional)
	3	B-	B+ (optional)
	11	Z+	B- (optional)
	4	Z-	Data+
	12	Encoder Alarm (optional)	Data-
5	DGND	Encoder Alarm (optional)	
13	U+	DGND	
6	U-	nc	
14	V+	nc	
7	V-	nc	
15	W+	Clk+	
8	W-	Clk-	
case	Shield	Shield	
DSUB-15 (f)	<p><u>Position Encoder Inputs (RS422):</u>                      Max. counting frequency: 25 M counts/s with quadrature decoding.                      A minimum of 40 ns edge separation must be guaranteed by the encoder under any circumstances!                      The maximal frequency of each signal is 6.25 MHz.</p> <p><u>Differential Hall Switch Inputs (RS422):</u>                      Input Frequency: &lt; 1 kHz</p> <p><u>Enc. Alarm In:</u>                      5 V / 1 mA</p> <p><u>Sensor Supply:</u>                      5 VDC max. 100 mA (300 mA since firmware version 6.7)</p>		
	* Since firmware version 6.6		
	** Since firmware version 6.7		

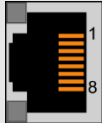

### 9.6 X17 – X18

X17 – X18	RealTime Ethernet 10/100 Mbit/s	
	X17 RT ETH In	Specification depends on RT Bus. Please refer to corresponding documentation.
	X18 RT ETH Out	
RJ-45		

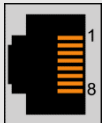
### 9.7 X19

X19	System	
	1	(Do not connect)
	2	(Do not connect)
	3	RS232 Rx
	4	GND
	5	GND
	6	RS232 Tx
	7	(Do not connect)
	8	(Do not connect)
case	Shield	
RJ-45	Use isolated USB-RS232 converter (Art.-No. 0150-2473) for configuration over RS232	

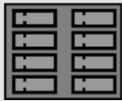
### 9.8 X33

X33	Safety Relays (only with the -1S option)			
X33.4/8 Ksr+ X33.3/7 Ksr- X33.2/6 Ksr f+ X33.1/5 Ksr f-	 STO Relays	4 / 8	Ksr +	Safety Relay 1 / 2 Input positive
3 / 7		Ksr -	Safety Relay 1 / 2 Input negative	
2 / 6		Ksr f+	Safety Relay 1 / 2 feedback positive	
1 / 5		Ksr f-	Safety Relay 1 / 2 feedback negative	
Spring cage connector (has to be ordered separately: see chapter 16)	<ul style="list-style-type: none"> <li>- Use 60/75°C copper conductors only</li> <li>- Conductor cross-section max. 1.5mm<sup>2</sup></li> <li>- Stripping length: 10mm</li> <li>- The state of the feedback contacts has to be checked after each change of the state of the control contacts!</li> <li>- Max. current on the feedback contacts (Ksr+ and Ksr-) has to be limited below 1 A.</li> </ul>			
	<b>- Never connect the safety relays to the logic supply of the drive!</b> → For detailed information see chapter 11 Safety Wiring.			



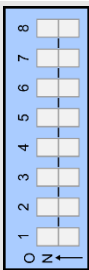

### 9.9 S1 – S2

S1 – S2	Address Selectors	
	S1 (5..8)	Bus ID High (0 ... F). Bit 5 is the LSB, bit 8 the MSB.
	S2 (1..4)	Bus ID Low (0 ... F). Bit 1 is the LSB, bit 4 the MSB.
<b>Setting the ID high &amp; low to 0xFF resets the drive to manufacturer settings!</b>		
The use of these switches depends on the type of fieldbus which is used. Please see the corresponding manual for further information.		



## 9.10 S5

S5	Bootstrap	
	S5	Bootstrap (Internal use only, set to off)





## 9.11 LEDs

LEDs	State Displays		
Error   24VOK Warn   EN	<b>Signal:</b> 24VOK	<b>Color:</b> Green	<b>Description:</b> 24 VDC Logic Supply OK
	EN	Yellow	Motor Enabled / Error Code Low Nibble
	Warn	Yellow	Warning / Error Code High Nibble
	Error	Red	Error

## 9.12 RT Bus LEDs

RT Bus LEDs	RT Bus State Display		
RT BUS   OK ERROR	<b>Signal:</b> OK	<b>Color:</b> Green	<b>Description:</b> OK
	RT BUS ERROR	Red	Error
The use of these LEDs depends on the type of fieldbus which is used. Please see the corresponding manual for further information			

### 10 LED Blink Codes

LED Blink Codes			
Error			24VOK
Warn			EN
Error	Warn	EN	Description
Off	Warning	Operation Enabled	<b>Normal Operation:</b> Warnings and operation enabled are displayed.
On	<ul style="list-style-type: none"> <li>• ~2 Hz</li> <li>0..15 x</li> </ul> Error Code High Nibble	<ul style="list-style-type: none"> <li>• ~2 Hz</li> <li>0..15 x</li> </ul> Error Code Low Nibble	<b>Error:</b> The error code is shown by a blink code with "WARN" and "EN" The error byte is divided into low and high nibble (= 4 bit). "WARN" and "EN" are blinking together. The error can be acknowledged. (e.g.: WARN blinks 3x, EN blinks 2x; Error Code = 32h)
<ul style="list-style-type: none"> <li>• ~2 Hz</li> </ul>	<ul style="list-style-type: none"> <li>• ~2 Hz</li> <li>0..15 x</li> </ul> Error Code High Nibble	<ul style="list-style-type: none"> <li>• ~2 Hz</li> <li>0..15 x</li> </ul> Error Code Low Nibble	<b>Fatal Error:</b> The error code is shown by a blink code with "WARN" and "EN". The error byte is divided into low and high nibble. "WARN" and "EN" are blinking together. Fatal errors can only be acknowledged by a reset or power cycle. (e.g.: WARN blinks 3x, EN blinks 2x; Error Code = 32h)
<ul style="list-style-type: none"> <li>• ~4 Hz</li> </ul>	<ul style="list-style-type: none"> <li>• ~2 Hz</li> <li>0..15 x</li> </ul> Error Code High Nibble	<ul style="list-style-type: none"> <li>• ~2 Hz</li> <li>0..15 x</li> </ul> Error Code Low Nibble	<b>System Error:</b> Please reinstall firmware or contact support.
<ul style="list-style-type: none"> <li>• ~0.5 Hz</li> </ul>	<ul style="list-style-type: none"> <li>• ~0.5 Hz</li> </ul>	Off	<b>Signal Supply 24V too low:</b> The error and warn LEDs blink alternating if the signal supply +24 VDC (X4.2) is less than 18 VDC.
Off	○●●●	●●●●	<b>Plug&amp;Play Communication Active:</b> This sequence (Warn on, then En on, then both off, complete sequence of the 4 states ca. 1 s) signals the state when the plug and play parameters are being read from the motor.
<ul style="list-style-type: none"> <li>○●</li> <li>~4 Hz</li> </ul>	<ul style="list-style-type: none"> <li>●○</li> <li>~4 Hz</li> </ul>	Off	<b>Waiting for Defaulting Parameters:</b> When ID (S1, S2) is set to 0xFF, the drive starts up in a special mode and the Error and Warn LED blink alternating ~4 Hz. When the ID is set to 0x00, all parameters will be set to their default value. To leave this state, power down the drive and change the ID. Also see in the Usermanual_LinMot-Talk under chapter trouble shooting.
Off	○●	○●	<b>Defaulting Parameters Done:</b> When the parameters have set to their default values (initiated via S1/S2 on power up) the Warn and En LEDs blink together at 2 Hz. To leave this state, power down the drive. Also see in the Usermanual_LinMot-Talk under chapter trouble shooting.

The meaning of the error codes can be found in the *Usermanual\_MotionCtrl\_Software\_SG5-SG7* and the user manual of the installed interface software. These documents are provided together with LinMot-Talk configuration software and can be downloaded from [www.linmot.com](http://www.linmot.com).



## 11 Safety Wiring

The C1250 drives with the -1S option have internal safety functions:  
 Two Safety relays Ksr in series, which support the supply voltage for the motor drivers. There are also two feedback contacts for each relay.

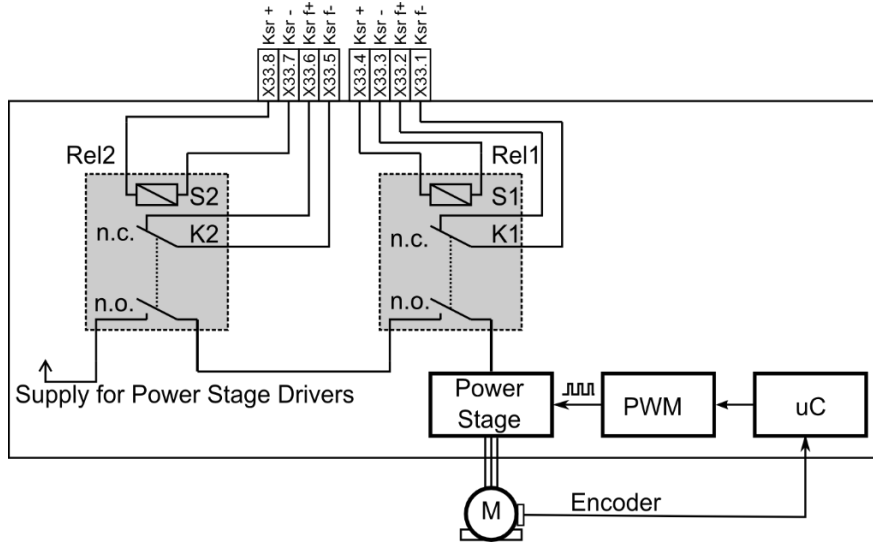

To enable the -1S drives both relays have to be switched on.

Minimal wiring:

- Connect X33.8 and X33.4 to 24 VDC (from safety)
- Connect X33.7 and X33.3 to GND (from safety)

**Never connect X33.8 and X33.4 to the logic supply of X4!  
 Never disconnect X33 when the STO is powered!**

**The overvoltage protection must be provided externally and sized according to the safety circuit of the machine (The voltage on any pin of X33 must be limited below 100V referenced to DGND)!**

**The drop out time of the relays is depending on the external circuitry!**

Safety Relay Ksr	
Nominal voltage	24 VDC
Min. pick-up voltage at 20°C	≤ 16.8 V
Drop-out voltage at 20°C	≥ 2.4 V
Drop-out time (no protection circuit)	Typ. 3 ms
Coil resistance at 20°C	2'100 Ω ± 10%
Type	EN 50205, type A
Contact lifetime	> 10'000'000
Manufacturer and type	Elesta relays / SIS112 24VDC
Maximum current on feedback contacts (Ksr f+ and Ksr-)	< 1 A

Drive Classification according EN ISO 13849-1 (safety of machinery)	
Category	cat = 3
Performance Level	PL = d
Diagnostic Coverage	DC = high (99%)
Mean Time to hazardous failure of one channel	MTTF <sub>d</sub> = high (100 years typically, see calculation example below)

**DC (Diagnostic Coverage) is high (99%) assuming that the state of the feedback contacts is checked after each change of the state of the control contacts.**

The  $MTTF_d$  mainly depends on the number of operations of the safety relays.

**Example calculation of  $MTTF_d$ :**

Assuming that the safety function is requested every 20 s on a machine running 24 h per day and 7 days per week.

$$B_{10} = 10'000'000$$

$$B_{10d} = 20'000'000 \text{ (according EN ISO 13849-1:2008 table C.1)}$$

$$n_{op} = (24 \text{ h/day} * 365.25 \text{ days/year} * 3600 \text{ s/h}) / 20 \text{ s} = 1'577'880 \text{ operations per year}$$

$$MTTF_d = B_{10d} / (0.1 * n_{op}) = 126.75 \text{ years}$$

(This has to be limited to 100 years according the standard for further calculations)

$$= \text{high (100 years)}$$

**12 Physical Dimension**

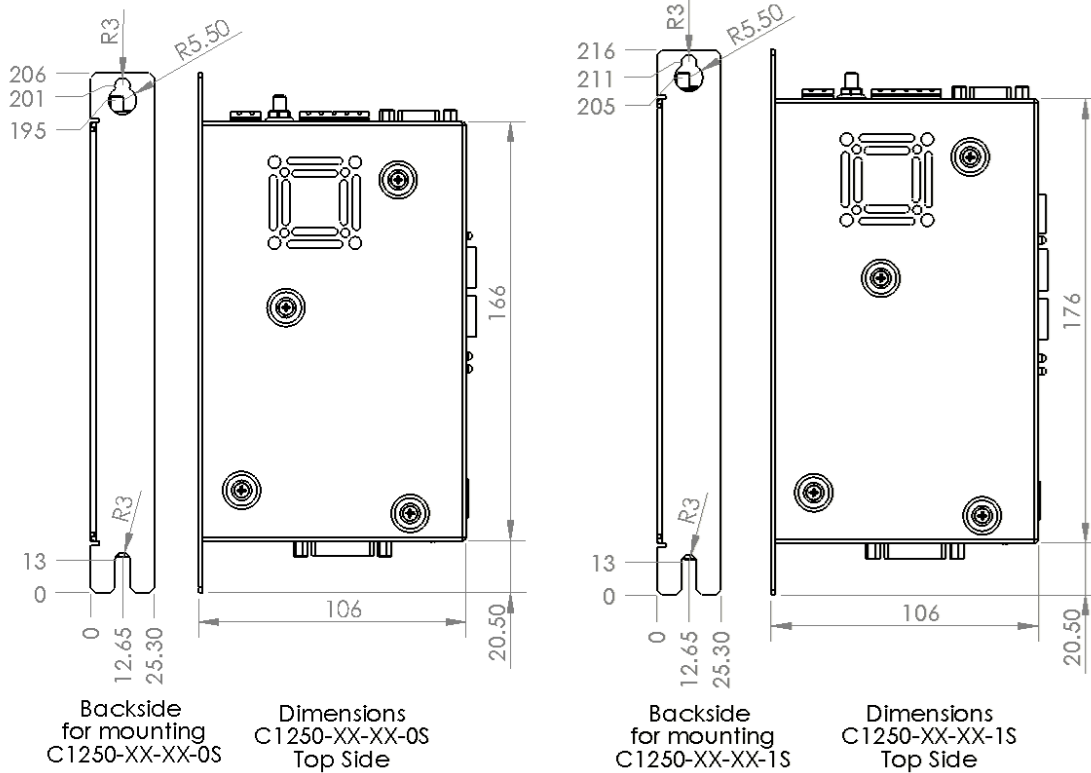

C1250 Series single axis drive		C1250-xx-XC-0S	C1250-xx-XC-1S
Width	mm (in)	25.3 (1.0)	
Height	mm (in)	166 (6.54)	176 (6.93)
Height with fixings	mm (in)	206 (8.11)	216 (8.50)
Depth	mm (in)	106 (4.2)	
Weight	g (lb)	630 (1.4)	700 (1.54)
Mounting Screws		2 x M5	2 x M5
Mounting Distance	mm (in)	188 (7.40)	198 (7.80)
Case, Degree of Protection	IP	20	
Storage Temperature	°C	-25...40	
Transport Temperature	°C	-25...70	
Operating Temperature	°C	0...40 at rated data (40...50 with power derating *)	
Relative humidity		< 95% (non-condensing)	
Pollution	IEC/EN 60664-1	Pollution degree 2	
Shock resistance (16ms)	-1S option		3.5g
Vibration resistance (10-200Hz)	-1S option		1g
Max. Case Temperature	°C	70	
Max. Power Dissipation	W	30	
Mounting place		In the control cabinet	
Mounting position		Vertical	
Distance between Drives	mm (in)	Without Power Derating *: 20 (0.8) horizontal / 50 (2) vertical With Power Derating *: 5 (0.2) horizontal / 20 (0.8) vertical	

\* The derating is depending on the situation in the cabinet. The temperature of the drive should be checked under full load (the temperature should be stable, which may take an hour or more). This allows to verify that enough margin is there if the cabinet goes to the maximum allowable temperature of 40° C. For example, if the drive temperature reaches 45° C and the cabinet temperature is 30° C, this would result in a drive temperature of about 55° C at a cabinet temperature of 40° C. The warning level of the drive is configured by default to 75° C and the error level to 80° C. In this example, everything is fine. If the drive temperature is long time above the warning level, this might result in a reduced lifetime of the drive.

## 13 Power Supply Requirements

### 13.1 Motor Power Supply

The calculation of the needed power for the Motor supply is depending on the application and the used motor. The nominal supply voltage is 72 VDC. The possible range is from 24 to 85 VDC.



The motor supply can rise up to 95 VDC when braking. This means that everything connected to that power supply needs a voltage rating of 100 VDC. (Additional capacitors, etc...). Due to high braking voltage and sudden load variations of linear motor applications, **only compatible power supplies can be used (see chapter 16 Ordering Information)**.

### 13.2 Signal Power Supply

The logic supply needs a regulated power supply of a nominal voltage of 24 VDC. The voltage must be between 22 and 26 VDC.

Current to be provided from the supply:

- min. 0.5 A (no load on the outputs)
- typ. 0.7 A (all 2 outputs "on" with 100 mA load and brake with no load)
- max. 2.0 A (all 2 outputs "on" with 500 mA peak load and brake with 500 mA peak load)



**Do not connect the safety relays to the 24 VDC Signal Supply!  
Use a separate power supply for the safety circuit**



**The 24 VDC supply for the control circuit must be protected with an external fuse (3 A slow blow)**

## 14 Regeneration

If the power supply rises too high when braking, connect an additional capacitor to the motor power supply. It is recommended to use a capacitor  $\geq 10'000 \mu\text{F}$  (install capacitor close to the drive supply!).

**15 Safety notes for the installation according UL****Markings:**

- Wiring terminal markings:  
See markings on the enclosure and the corresponding chapters in the installation guide!
- Cautionary Marking:  
See markings on the enclosure and the corresponding chapters in the installation guide!
- The transients have to be limited to max. 0.8 kV on the line side of the drive.
- The 24 VDC supply for the control circuit must be protected with an external UL Listed 3 A DC fuse.
- **A separate 24 VDC power supply protected with an external UL Listed 3 A fuse connected to the output of the power supply must be used to protect the secondary control circuit (safety relays on X33)**
- Integral solid state short circuit protection does not provide branch circuit protection. Branch circuit protection must be provided in accordance with the National Electrical Code and any additional local codes.

**Markings for cURus (available until Hardware Version 1, Revision H4):**

- Proposed ratings, to be evaluated in the end-use:
  - Input Voltage: 72 VDC
  - Input current: 15 A
  - Output Voltage: 61.5 V rms
  - Output Current: 17.7 A rms
  - Number of Phases: 2 by 1 Phase
  - Frequency range: 0-500 Hz
  - Duty cycle rating: 10%
  - Relays (only for -1S variant):
    - Rated Contacts: max. 24 VDC, 6 A
    - Coil: 24 VDC
    - Surrounding air temp: max. 85 °C
  - Control Power (X4.2): 24 VDC (Protected with an external UL Listed 3 A fuse)
  - Surrounding Air Temperature: max. 50 °C

**Markings for cULus (available from Hardware Version 1, Revision H2):**

- Ratings:
  - Input Voltage: 72 VDC
  - Input current: 6.5 A
  - Output Voltage: 43 V rms
  - Output Current: 5 A rms
  - Number of Phases: 2 by 1 Phase
  - Frequency range: 0-599 Hz
  - Duty cycle rating: 4 - 96%
  - Relays (only for -1S variant):
    - Rated Contacts: max. 24 VDC, 6 A
    - Coil: 24 VDC
    - Surrounding air temp: max. 85 °C
  - Control Power (X4.2): 24 VDC (Protected with an external UL Listed 3 A fuse)
  - Surrounding Air Temperature: max. 50 °C
- Suitable for use on a circuit capable of delivering not more than 5 kADC, 72 VDC maximum.  
(Branch circuit protection on X1: External Circuit Breaker: 15 A / min. 100 VDC / C-Trip / 5 kA rms SCCR)

### 16 Ordering Information

Drives	Description	Art. No.
C1250-PN-XC-0S-000	PROFINET Drive (72V/25A)	0150-1888
C1250-PD-XC-0S-000	PROFINET Profdrive Drive (72V/25A)	0150-2618
C1250-IP-XC-0S-000	ETHERNET IP Drive (72V/25A)	0150-1886
C1250-LU-XC-0S-000	ETHERNET LinUDP Drive (72V/25A)	0150-2491
C1250-EC-XC-0S-000	ETHERCAT Drive (72V/25A)	0150-1884
C1250-DS-XC-0S-000	ETHERCAT CiA402 Drive (72V/25A)	0150-2415
C1250-SE-XC-0S-000	ETHERCAT SoE Drive (72V/25A)	0150-1897
C1250-PL-XC-0S-000	POWERLINK Drive (72V/25A)	0150-1885
C1250-SC-XC-0S-000	SERCOS III Drive (72V/25A)	0150-1887
C1250-CM-XC-0S-000	CIP Sync Drive (72V/25A)	0150-2900
C1250-CC-XC-0S-000	CC Link Drive (72V/25A)	0150-4023
C1250-PN-XC-1S-000	PROFINET Drive (72V/25A/STO)	0150-2348
C1250-PD-XC-1S-000	PROFINET Profdrive Drive (72V/25A/STO)	0150-2619
C1250-IP-XC-1S-000	ETHERNET IP Drive (72V/25A/STO)	0150-2346
C1250-LU-XC-1S-000	ETHERNET LinUDP Drive (72V/25A/STO)	0150-2492
C1250-EC-XC-1S-000	ETHERCAT Drive (72V/25A/STO)	0150-2345
C1250-DS-XC-1S-000	ETHERCAT CiA402 Drive (72V/25A/STO)	0150-2416
C1250-SE-XC-1S-000	ETHERCAT SoE Drive (72V/25A/STO)	0150-2350
C1250-PL-XC-1S-000	POWERLINK Drive (72V/25A/STO)	0150-2347
C1250-SC-XC-1S-000	SERCOS III Drive (72V/25A/STO)	0150-2349
C1250-CM-XC-1S-000	CIP Sync Drive (72V/25A/STO)	0150-2901
C1250-CC-XC-1S-000	CC Link Drive (72V/25A/STO)	0150-4024
Calibrated Drives	Description	Art. No.
C1250-PN-XC-0S-C00	PROFINET Drive (72V/25A), Calibrated Measuring Amplifier	0150-4140
C1250-PD-XC-0S-C00	PROFINET Profdrive Drive (72V/25A), Calibrated Measuring Amplifier	0150-4136
C1250-IP-XC-0S-C00	ETHERNET IP Drive (72V/25A), Calibrated Measuring Amplifier	0150-4127
C1250-LU-XC-0S-C00	ETHERNET LinUDP Drive (72V/25A), Calibrated Measuring Amplifier	0150-4129
C1250-EC-XC-0S-C00	ETHERCAT Drive (72V/25A), Calibrated Measuring Amplifier	0150-4125
C1250-DS-XC-0S-C00	ETHERCAT CiA402 Drive (72V/25A), Calibrated Measuring Amplifier	0150-4123
C1250-SE-XC-0S-C00	ETHERCAT SoE Drive (72V/25A), Calibrated Measuring Amplifier	0150-4144
C1250-PL-XC-0S-C00	POWERLINK Drive (72V/25A), Calibrated Measuring Amplifier	0150-4138
C1250-SC-XC-0S-C00	SERCOS III Drive (72V/25A), Calibrated Measuring Amplifier	0150-4142
C1250-CM-XC-0S-C00	CIP Sync Drive (72V/25A), Calibrated Measuring Amplifier	0150-4121
C1250-CC-XC-0S-C00	CC Link Drive (72V/25A), Calibrated Measuring Amplifier	0150-4146
C1250-PN-XC-1S-C00	PROFINET Drive (72V/25A/STO), Calibrated Measuring Amplifier	0150-4141
C1250-PD-XC-1S-C00	PROFINET Profdrive Drive (72V/25A/STO), Calibrated Measuring Amplifier	0150-4137
C1250-IP-XC-1S-C00	ETHERNET IP Drive (72V/25A/STO), Calibrated Measuring Amplifier	0150-4128
C1250-LU-XC-1S-C00	ETHERNET LinUDP Drive (72V/25A/STO), Calibrated Measuring Amplifier	0150-4135
C1250-EC-XC-1S-C00	ETHERCAT Drive (72V/25A/STO), Calibrated Measuring Amplifier	0150-4126
C1250-DS-XC-1S-C00	ETHERCAT CiA402 Drive (72V/25A/STO), Calibrated Measuring Amplifier	0150-4124
C1250-SE-XC-1S-C00	ETHERCAT SoE Drive (72V/25A/STO), Calibrated Measuring Amplifier	0150-4145
C1250-PL-XC-1S-C00	POWERLINK Drive (72V/25A/STO), Calibrated Measuring Amplifier	0150-4139
C1250-SC-XC-1S-C00	SERCOS III Drive (72V/25A/STO), Calibrated Measuring Amplifier	0150-4143
C1250-CM-XC-1S-C00	CIP Sync Drive (72V/25A/STO), Calibrated Measuring Amplifier	0150-4122
C1250-CC-XC-1S-C00	CC Link Drive (72V/25A/STO), Calibrated Measuring Amplifier	0150-4147

Accessories	Description	Art. No.
<b>DC01-C1X00-0S/X1/X4</b>	<b>Drive Connector Set for C1X00-0S</b>	<b>0150-3527</b>
<b>DC01-C1X00-1S/X1/X4/X33</b>	<b>Drive Connector Set for C1X00-1S</b>	<b>0150-3528</b>
DC01-C1X00/X1	Drive Connector for PWR 72 VDC Input	0150-3525
DC01-C1X00/X2	Drive Connector Motor Phases	0150-3526
DC01-Signal/X4	Drive Connector 24 VDC & Logic	0150-3447
DC01-Safety/X33	Drive Connector Safety	0150-3451
<b>Isolated USB-RS232 converter</b>	<b>Isolated USB RS232 converter with config. cable</b>	<b>0150-2473</b>
Isolated USB-serial converter	Isolated USB RS232/422/485 converter	0150-3120
Recalibration Service	Calibration Drive Series C1200 (Calibration of analog inputs on X4 of C1250-xx-XC-xS-Cxx Drives)	0150-4164
Compatible Power Supplies		Art. No.
S01-72/1000	Power Supply 72 V/1000 W, 3x340-550 VAC	0150-1872
S02-72/1000	Power Supply 72V/1000W, 3x400-480VAC	0150-4535
S01-72/500	Power Supply 72 V/500 W, 1x120/230 VAC	0150-1874
S01-24/500	Power Supply 24 V/500 W, 1x120/230 VAC	0150-2480
S01-48/300	Power Supply 48 V/300 W, 1x120/230 VAC	0150-1941
S01-48/600	Power Supply 48 V/600 W, 1x120/230 VAC	0150-1946
T01-72/420-Multi	T-Supply 72 V / 420 VA, 3x230/400/480 VAC	0150-1869
T01-72/900-Multi	T-Supply 900 VA, 3x230/400/480 VAC	0150-1870
T01-72/1500-Multi	T-Supply 1500 VA, 3x230/400/480 VAC	0150-1871
T01-72/420 -1ph	T-Supply 420 VA, 1x208/220/230/240 VAC	0150-1859

Bold items are strongly recommended accessories!







The connectors have to be ordered separately and are not included with the drive!



Use isolated USB RS232 converter for configuration!

### 17 International Certifications

Certifications	
<p>Europe</p> 	See chapter 18 EU Declaration of Conformity CE-Marking
<p>UK</p> 	See chapter 19 UK Declaration of Conformity UKCA-Marking
<p>IECEE CB SCHEME</p>	Ref. Certif. No. CH-7685
<p>USA / Canada</p> 	<p>All products marked with this symbol are tested and recognized by Underwriters Laboratories and the production facilities are checked quarterly by an UL inspector. This mark is valid for the USA and Canada and eases certification of your machines and systems in these areas.</p> <p>File number E316095 UL 508C Power Conversion Equipment CSA C22.2 Industrial Control Equipment</p> <p><b>Available until Hardware Version 1, Revision H4</b></p>
<p>USA / Canada</p> 	<p>All products marked with this symbol are tested and listed by Underwriters Laboratories and the production facilities are checked quarterly by an UL inspector. This mark is valid for the USA and Canada and eases certification of your machines and systems in these areas.</p> <p>File number E316095 UL 508C Power Conversion Equipment CSA C22.2 Industrial Control Equipment</p> <p><b>Available from Hardware Version 1, Revision H2</b></p>



	Ref. Certif. No.
	CH-7685

IEC SYSTEM FOR MUTUAL RECOGNITION OF TEST CERTIFICATES FOR ELECTRICAL EQUIPMENT (IECEE) CB SCHEME	SYSTEME CEI D'ACCEPTATION MUTUELLE DE CERTIFICATS D'ESSAIS DES EQUIPMENTS ELECTRIQUES (IECEE) METHODE OC
---	--

**CB TEST CERTIFICATE / CERTIFICAT D'ESSAI OC**

Product  
Produit

Name and address of the applicant  
Nom et adresse du demandeur

Name and address of the manufacturer  
Nom et adresse du fabricant

Name and address of the factory  
Nom et adresse de l'usine

*Note: When more than one factory, please report on page 2  
Note: Lorsque il y plus d'une usine, veuillez utiliser la 2<sup>ème</sup> page*

Ratings and principal characteristics  
Valeurs nominales et caractéristiques principales

Trade mark (if any)  
Marque de fabrique (si elle existe)

Type of Manufacturer's Testing Laboratories used  
Type de programme du laboratoire d'essais constructeur

Model / Type Ref.  
Ref. de type

Additional information (if necessary may also be reported on page 2)  
Les informations complémentaires (si nécessaire, peuvent être indiqués sur la 2<sup>ème</sup> page

A sample of product was tested and found to be in conformity with IEC  
Un échantillon de ce produit a été essayé et a été considéré conforme à la CEI

National differences / Comments  
Les différences nationales / Commentaires

As shown in the Test Report Ref. No. which forms part of this Certificate  
Comme indiqué dans le Rapport d'essais numéro de référence qui constitue partie de ce Certificat

Servo drive unit

NTI AG	Linmot Haerdlistrasse 15 CH-8957 Spreitenbach	Switzerland
NTI AG	Linmot Haerdlistrasse 15 CH-8957 Spreitenbach	Switzerland
NTI AG	Linmot Haerdlistrasse 15 CH-8957 Spreitenbach	Switzerland

Additional Information on page 2

Motor supply: 72 VDC (24 – 85 VDC), 15 A  
Logic supply: 24 VDC (22 – 26 VDC), 3 A  
Class I

LinMot

---

C1250 Servo Drive / C1250-IP-XC-1 S-000

---

Additional Information on page 2

61000-6-2(ed.2)  
61000-6-4(ed.2);am1

EU Group Differences;  
EU Special National Conditions;  
EU A-Deviations

14-IK-0141.E03



This CB Test Certificate is issued by the National Certification Body  
Ce Certificat d'essai OC est établi par l'Organisme National de Certification

Electrosuisse  
Luppenstrasse 1,  
CH-8320 Fehraltorf

Signed by: Martin Plüss  
2014-12-03

page 1 of 2



Ref. Certif. No.

CH-7685

Additional information (if necessary)  
Information complémentaire (si nécessaire)

Type list

Type	Modelnumber	Ratings	
C1250-PN-XC-0S-000	0150-1888	PROFINET Drive	(72 VDC/25 A)
C1250-PD-XC-0S-000	0150-2618	PROFINET Profidrive Drive	(72 VDC/25 A)
C1250-IP-XC-0S-000	0150-1886	ETHERNET IP Drive	(72 VDC/25 A)
C1250-EC-XC-0S-000	0150-1884	ETHERCAT Drive	(72 VDC/25 A)
C1250-DS-XC-0S-000	0150-2415	ETHERCAT CiA402 Drive	(72 VDC/25 A)
C1250-SE-XC-0S-000	0150-1897	ETHERCAT SoE Drive	(72 VDC/25 A)
C1250-PL-XC-0S-000	0150-1885	POWERLINK Drive	(72 VDC/25 A)
C1250-SC-XC-0S-000	0150-1887	SERCOS III Drive	(72 VDC/25 A)
C1250-PN-XC-1S-000	0150-2348	PROFINET Drive	(72 VDC/25 A/STO)
C1250-PD-XC-1S-000	0150-2619	PROFINET Profidrive Drive	(72 VDC/25 A/STO)
C1250-IP-XC-1S-000	0150-2346	ETHERNET IP Drive	(72 VDC/25 A/STO)
C1250-EC-XC-1S-000	0150-2345	ETHERCAT Drive	(72 VDC/25 A/STO)
C1250-DS-XC-1S-000	0150-2416	ETHERCAT CiA402 Drive	(72 VDC/25 A/STO)
C1250-SE-XC-1S-000	0150-2350	ETHERCAT SoE Drive	(72 VDC/25 A/STO)
C1250-PL-XC-1S-000	0150-2347	POWERLINK Drive	(72 VDC/25 A/STO)
C1250-SC-XC-1S-000	0150-2349	SERCOS III Drive	(72 VDC/25 A/STO)

Nomenclature

Code	Description
C1200-	Drive type (Equipment containing Ethernet has an xxx50)
GP-	Interface
LC-	Power output
0S-	Functional safety option
000	Individual extension (e.g. customer related firmware option etc.)

Interfaces			Power output	
Code	Abbr.	Description	Code	Description
0	GP	General Purpose	LC	8 A peak
0	CO	CANopen	HC	15 A peak
0	DN	DeviceNet	XC	25 A peak
10	VF	Velocity and Force	UC	32 A peak
30	DP	PROFIBUS DP		
50	EC	ETHERCAT		
50	PN	ProfiNet		
50	SE	SERCOS over ETHERCAT		
50	PL	POWERLINK		
50	PN	Profinet		
50	PD	Profinet mit Profidrive		
50	IP	ETHERNET IP		
50	SC	SERCOS III		

This CB Test Certificate is issued by the National Certification Body  
Ce Certificat d'essai OC est établi par l'Organisme National de Certification

Electrosuisse  
Luppmenstrasse 1,  
CH-8320 Fehraltorf

Signed by: Martin Plüss  
2014-12-03



page 2 of 2

## CERTIFICATE OF COMPLIANCE

**Certificate Number** 20140317-E316095  
**Report Reference** E316095-20140307  
**Issue Date** 2014-March-17

**Issued to:** NTI AG  
 HAERDLISTRASSE 15,  
 8957 SPREITENBACH SWITZERLAND



**This is to certify that representative samples of** COMPONENT - POWER CONVERSION EQUIPMENT  
 SEE ADDENDUM PAGE FOR MODELS

Have been investigated by UL in accordance with the Standard(s) indicated on this Certificate.

**Standard(s) for Safety:** UL 508C - Power Conversion Equipment  
 CSA C22.2 NO. 14-13- INDUSTRIAL CONTROL EQUIPMENT.

**Additional Information:** See the UL Online Certifications Directory at [www.ul.com/database](http://www.ul.com/database) for additional information

Only those products bearing the UL Recognized Component Marks for the U.S. and Canada should be considered as being covered by UL's Recognition and Follow-Up Service and meeting the appropriate U.S. and Canadian requirements.

The UL Recognized Component Mark for the U.S. generally consists of the manufacturer's identification and catalog number, model number or other product designation as specified under "Marking" for the particular Recognition as published in the appropriate UL Directory. As a supplementary means of identifying products that have been produced under UL's Component Recognition Program, UL's Recognized Component Mark:  may be used in conjunction with the required Recognized Marks. The Recognized Component Mark is required when specified in the UL Directory preceding the recognitions or under "Markings" for the individual recognitions. The UL Recognized Component Mark for Canada consists of the UL Recognized Mark for Canada:  and the manufacturer's identification and catalog number, model number or other product designation as specified under "Marking" for the particular Recognition as published in the appropriate UL Directory.

Recognized components are incomplete in certain constructional features or restricted in performance capabilities and are intended for use as components of complete equipment submitted for investigation rather than for direct separate installation in the field. The final acceptance of the component is dependent upon its installation and use in complete equipment submitted to UL LLC.

Look for the UL Recognized Component Mark on the product.

William R. Carney, Director, North American Certification Programs  
 UL LLC

Any information and documentation involving UL Mark services are provided on behalf of UL LLC (UL) or any authorized licensee of UL. For questions, please contact a local UL Customer Service Representative at [www.ul.com/contact](http://www.ul.com/contact)



**CERTIFICATE OF COMPLIANCE**

**Certificate Number** 20140317-E316095  
**Report Reference** E316095-20140307  
**Issue Date** 2014-March-17

This is to certify that representative samples of the product as specified on this certificate were tested according to the current UL requirements.

**Open type Power Conversion Equipment Models:**

- Model A, may be followed by P, followed by 11, followed by 00, 30 or 50, followed by -, followed by GP, PL, PN, SC, IP, EC, SE, PD, DP, VA, CO, CD, DN, DS, CM, or LU, followed by -, followed by LC, followed by -0S, may be followed by - and any characters.

- Model C, may be followed by P, followed by 11 or 12, followed by 00, 30 or 50, followed by -, followed by GP, PL, PN, SC, IP, EC, SE, PD, DP, VA, CO, CD, DN, DS, CM, or LU, followed by -, followed by XC, followed by -0S or -1S, may be followed by - and any characters.

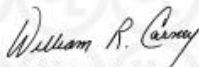

William R. Carney, Director, North American Certification Programs  
UL LLC

Any information and documentation involving UL Mark services are provided on behalf of UL LLC (UL) or any authorized licensee of UL. For questions, please contact a local UL Customer Service Representative at [www.ul.com/contactus](http://www.ul.com/contactus).



# CERTIFICATE OF COMPLIANCE

**Certificate Number** E316095  
**Report Reference** E316095-20190630  
**Issue Date** 2020-FEBRUARY-28

**Issued to:** NTI AG  
 Bodenaeckerstr 2  
 8957 SPREITENBACH SWITZERLAND

**This certificate confirms that representative samples of**

**POWER CONVERSION EQUIPMENT**

Open type Power Conversion Equipment, model C, may be followed by P, followed by 12, followed by 00, 30, 50 or 51, followed by -, followed by GP, PL, PN, SC, IP, EC, SE, PD, DP, VA, CO, CD, MI, DN, DS, CC, CM, or LU, followed by -, followed by XC, followed by -0S or -1S, may be followed by – and any characters which describe software non-critical features

Have been investigated by UL in accordance with the Standard(s) indicated on this Certificate.

**Standard(s) for Safety:** UL 508C Power Conversion Equipment  
 CAN/CSA C22.2 No. 274-17- Adjustable speed drives.

**Additional Information:** See the UL Online Certifications Directory at <https://iq.ulprospector.com> for additional information.

This *Certificate of Compliance* does not provide authorization to apply the UL Mark. Only the UL Follow-Up Services Procedure provides authorization to apply the UL Mark.

Only those products bearing the UL Mark should be considered as being UL Certified and covered under UL's Follow-Up Services.

Look for the UL Certification Mark on the product.

Bruce Mahrenholz, Director North American Certification Program  
 UL LLC

Any information and documentation involving UL Mark services are provided on behalf of UL LLC (UL) or any authorized licensee of UL. For questions, please contact a local UL Customer Service Representative at <http://ul.com/aboutul/locations/>





### Declaration of Conformity to the EtherNet/IP™ Specification

ODVA hereby issues this Declaration of Conformity to *The EtherNet/IP™ Specification* for the product(s) described below. The Vendor listed below (the "Vendor") holds a valid Terms of Usage Agreement, which is incorporated herein by reference, for the EtherNet/IP Technology from ODVA, thereby agreeing that it is the Vendor's ultimate responsibility to assure that its EtherNet/IP Compliant Products conform to *The EtherNet/IP Specification* and that *The EtherNet/IP Specification* is provided by ODVA to the Vendor on an AS IS basis without warranty. NO WARRANTIES, EXPRESSED OR IMPLIED, INCLUDING WITHOUT LIMITATION ANY WARRANTIES OF MERCHANTABILITY OR FITNESS FOR A PARTICULAR PURPOSE, ARE BEING PROVIDED BY ODVA.

In recognition of the below EtherNet/IP Compliant Product(s) having been EtherNet/IP Conformance Tested at ODVA-authorized Test Service Provider and having received a passing result from ODVA at the Composite Test Revision Level specified below, this Declaration of Conformity authorizes the Vendor to use the EtherNet/IP Certification Marks in conjunction with the specific EtherNet/IP Compliant Product(s) described below, for so long as the Vendor's Terms of Usage Agreement for the EtherNet/IP Technology remains valid.



Certification Logo Mark

EtherNet/IP CONFORMANCE TESTED™

Certification Word Mark

This Declaration of Conformity is issued on February 2, 2015 on behalf of ODVA by:

Katherine Voss  
Executive Director

Vendor Information				
Vendor Name	NTI Limited			
Test Information				
Test Date	December 11, 2014			
Composite Test Revision	CT11			
ODVA File Number	11332.01			
Product Information		Network Category:	Node	
Identity Object Instance				
Vendor ID (Attribute 1)	589			
Device Type (Attribute 2)	0x2B			
Device Profile Name	Generic Device (keyable)			
Products Covered under this Declaration of Conformity (Identity Object Instance)				
No.	Product Code (Attribute 3)	Product Name (Attribute 7)	Product Revision (Attribute 4)	SOC File Name
1	1886	C1250IPXC0S	1.001	C1250IPXC0S.stc
2	2346	C1250IPXC1S	1.001	C1250IPXC1S.stc
3	1761	E1250-IP-UC	1.001	Not Tested
4	1782	E1450IPQN0S	1.001	Not Tested
5	2354	E1450IPQN1S	1.001	Not Tested
6	2610	C1450IPQN0S	1.001	Not Tested
7	2611	C1450IPQN1S	1.001	Not Tested
8	2612	C1450IPQD0S	1.001	Not Tested
9	2613	D1450IPVRO0S	1.001	Not Tested
10	2614	D1450IPQD0S	1.001	Not Tested
11	2615	D1250IPXC0S	1.001	Not Tested

EtherNet/IP and EtherNet/IP CONFORMANCE TESTED logo mark and word mark are trademarks of ODVA, Inc.

Copyright © ODVA, Inc. 2004-2013

PUB00033R7

www.odva.org

Page 1 of 1

## 18 EU Declaration of Conformity CE-Marking

NTI AG / LinMot ®  
Bodenaeckerstrasse 2  
8957 Spreitenbach  
Switzerland  
Tel.: +41 (0)56 419 91 91  
Fax: +41 (0)56 419 91 92

declares under sole responsibility the compliance of the products:

- Drives of the Series **C1250-xx-XC-xS-xxx**

with the EMC Directive 2014/30/EU.

Applied harmonized standards:

- **EN 61000-6-2: 2005 (Immunity for industrial environments)**
- **EN 61000-6-4: 2007 + A1:2011 (Emission for industrial environments)**

According to the EMC directive, the listed devices are not independently operable products.

Compliance of the directive requires the correct installation of the product, the observance of specific installation guides and product documentation. This was tested on specific system configurations.

The safety instructions of the manuals are to be considered.

The product must be mounted and used in strict accordance with the installation instructions contained within the installation guide, a copy of which may be obtained from NTI AG.

Company: NTI AG  
Spreitenbach, 11.04.2016



-----  
Dr. Ronald Rohner / CEO NTI AG

**19 UK Declaration of Conformity UKCA-Marking**

NTI AG / LinMot ®  
Bodenaeckerstrasse 2  
8957 Spreitenbach  
Switzerland  
Tel.: +41 (0)56 419 91 91  
Fax: +41 (0)56 419 91 92

declares under sole responsibility the compliance of the products:

- Drives of the Series **C1250-xx-XC-xS-xxx**

with the EMC Regulation S.I. 2016 No. 1091.

Applied designated standards:

- **EN 61000-6-2: 2005 (Immunity for industrial environments)**
- **EN 61000-6-4: 2007 + A1:2011 (Emission for industrial environments)**

According to the EMC regulation, the listed devices are not independently operable products.

Compliance of the regulation requires the correct installation of the product, the observance of specific installation guides and product documentation. This was tested on specific system configurations.

The safety instructions of the manuals are to be considered.

The product must be mounted and used in strict accordance with the installation instructions contained within the installation guide, a copy of which may be obtained from NTI AG.

Company: NTI AG  
Spreitenbach, 23.03.2022



-----  
Dr. Ronald Rohner / CEO NTI AG



**20 Contact & Support**

**SCHWEIZ**

**NTI AG**  
Bodenaeckerstr. 2  
CH-8957 Spreitenbach

Sales and Administration: +41-(0)56-419 91 91  
[office@linmot.com](mailto:office@linmot.com)

Tech. Support: +41-(0)56-544 71 00  
[support@linmot.com](mailto:support@linmot.com)  
<http://www.linmot.com/support>

Tech. Support (Skype): <skype:support.linmot>

Fax: +41-(0)56-419 91 92  
Web: <http://www.linmot.com/>

---

**USA**

**LinMot USA Inc.**  
N1922 State Road 120, Unit 1  
Lake Geneva, WI 53147  
USA

Phone 262-743-2555

E-Mail: [usasales@linmot.com](mailto:usasales@linmot.com)  
Web: <http://www.linmot-usa.com/>

---

Please visit <http://www.linmot.com/contact> to find the distribution close to you.

Smart solutions are...

