

C1100 Servo Drives

Installation Guide



Important Notice:

Please note that we use machine translation to provide documents in your local language. It is possible that not all texts will be translated correctly. If you have any questions or discrepancies regarding the accuracy of the information in the translated version, please read the original English version ([0185-1062-E](#))

Please visit <http://www.linmot.com> to check for the latest version of this document!

© 2024 NTI AG

This work is protected by copyright.

Under the copyright laws, this publication may not be reproduced or transmitted in any form, electronic or mechanical, including photocopying, recording, microfilm, storing in an information retrieval system, not even for didactical use, or translating, in whole or in part, without the prior written consent of NTI AG.

LinMot[®] is a registered trademark of NTI AG.

Note

The information in this documentation reflects the stage of development at the time of press and is therefore without obligation. NTI AG reserves itself the right to make changes at any time and without notice to reflect further technical advance or product improvement.

NTI AG
LinMot[®]
Bodenaeckerstrasse 2
CH-8957 Spreitenbach

Tel.: +41 (0)56 419 91 91
Fax: +41 (0)56 419 91 92
Email: office@LinMot.com
Homepage: www.LinMot.com

Table of Contents

Table of Contents 3

1 Important Safety Instructions 4

2 System Overview..... 6

3 Interfaces 7

4 Functionality 9

5 Software 9

6 Power Supply and Grounding..... 10

7 Description of the connectors / Interfaces 11

 7.1 PE..... 11

 7.2 X1 11

 7.3 X2/X3 Motor Connection 11

 7.4 X4 13

 7.5 X7 – X8..... 13

 7.6 X13 14

 7.7 X17 – X18..... 14

 7.8 X19 15

 7.9 X33 15

 7.10 S1 – S2..... 15

 7.11 S4 16

 7.12 S5..... 16

 7.13 LEDs..... 16

 7.14 RT Bus LEDs..... 16

8 LED Blink Codes 17

9 Safety Wiring 18

10 Physical Dimension 20

11 Power Supply Requirements..... 21

 11.1 Motor Power Supply 21

 11.2 Signal Power Supply 21

12 Regeneration Resistor..... 21

13 Safety notes for the installation according UL 22

14 Ordering Information 23

15 International Certifications..... 24

16 EU Declaration of Conformity CE-Marking 29

17 UK Declaration of Conformity UKCA-Marking 30

18 Contact & Support..... 31

1 Important Safety Instructions



For your personal safety

Disregarding the following safety measures can lead to severe injury to persons and damage to material:

- Only use the product as directed.
- Never commission the product in the event of visible damage.
- Never commission the product before assembly has been completed.
- Do not carry out any technical changes on the product.
- Only use the accessories approved for the product.
- Only use original spare parts from LinMot.
- Observe all regulations for the prevention of accidents, directives and laws applicable on site.
- Transport, installation, commissioning and maintenance work must only be carried out by qualified personnel.
 - Observe IEC 364 and CENELEC HD 384 or DIN VDE 0100 and IEC report 664 or DIN VDE 0110 and all national regulations for the prevention of accidents.
 - According to the basic safety information, qualified, skilled personnel are persons who are familiar with the assembly, installation, commissioning, and operation of the product and who have the qualifications necessary for their occupation.
- Observe all specifications in this documentation.
 - This is the condition for safe and trouble-free operation and the achievement of the specified product features.
 - The procedural notes and circuit details described in this documentation are only proposals. It is up to the user to check whether they can be transferred to the particular applications. NTI AG / LinMot does not accept any liability for the suitability of the procedures and circuit proposals described.
- LinMot servo drives and the accessory components can include live and moving parts (depending on their type of protection) during operation. Surfaces can be hot.
 - Non-authorized removal of the required cover, inappropriate use, incorrect installation or operation create the risk of severe injury to persons or damage to material assets.
 - For more information, please see the documentation.
- High amounts of energy are produced in the drive. Therefore it is required to wear personal protective equipment (body protection, headgear, eye protection, hand guard).

Application as directed

- Drives are components which are designed for installation in electrical systems or machines. They are not to be used as domestic appliances, but only for industrial purposes according to EN 61000-3-2.
- When drives are installed into machines, commissioning (i.e. starting of the operation as directed) is prohibited until it is proven that the machine complies with the regulations of the EC Directive 98/37/EC (Machinery Directive); EN 60204 must be observed.
- Commissioning (i.e. starting of the operation as directed) is only allowed when there is compliance with the EMC Directive (2004/108/EC).
- The technical data and supply conditions can be obtained from the nameplate and the documentation. They must be strictly observed.

Transport, storage

- Please observe the notes on transport, storage, and appropriate handling.
- Observe the climatic conditions according to the technical data.

Installation

- The drives must be installed and cooled according to the instructions given in the corresponding documentation.
- The ambient air must not exceed degree of pollution 2 according to EN 61800-5-1.
- Ensure proper handling and avoid excessive mechanical stress. Do not bend any components and do not change any insulation distances during transport or handling. Do not touch any electronic components and contacts.
- Drives contain electrostatic sensitive devices which can easily be damaged by inappropriate handling. Do not damage or destroy any electrical components since this might endanger your health!

Electrical connection



When working on live drives, observe the applicable national regulations for the prevention of accidents.

The electrical installation must be carried out according to the appropriate regulations (e.g. cable cross-sections, fuses, PE connection). Additional information can be obtained from the documentation.

This product can cause high-frequency interferences in non-industrial environments which can require measures for interference suppression.

Operation

- If necessary, systems including drives must be equipped with additional monitoring and protection devices according to the valid safety regulations (e.g. law on technical equipment, regulations for the prevention of accidents). The drives can be adapted to your application. Please observe the corresponding information given in the documentation.
- After the drive has been disconnected from the supply voltage, all live components and power connections must not be touched immediately because capacitors can still be charged. Please observe the corresponding stickers on the drive. All protection covers and doors must be shut during operation.

Protection of persons



The power terminals Ph1+, Ph1-, Ph2+, Ph2- and PWR+ remain live for at least 5 minutes after disconnecting from the power supplies.

Before servicing, disconnect supply, wait 5 minutes and measure between PWR+ and PGND to be sure that the capacitors have discharged below 42VDC.



The heat sink of the drive can have an operating temperature of $> 80\text{ °C}$: Contact with the heat sink results in burns.

2 System Overview

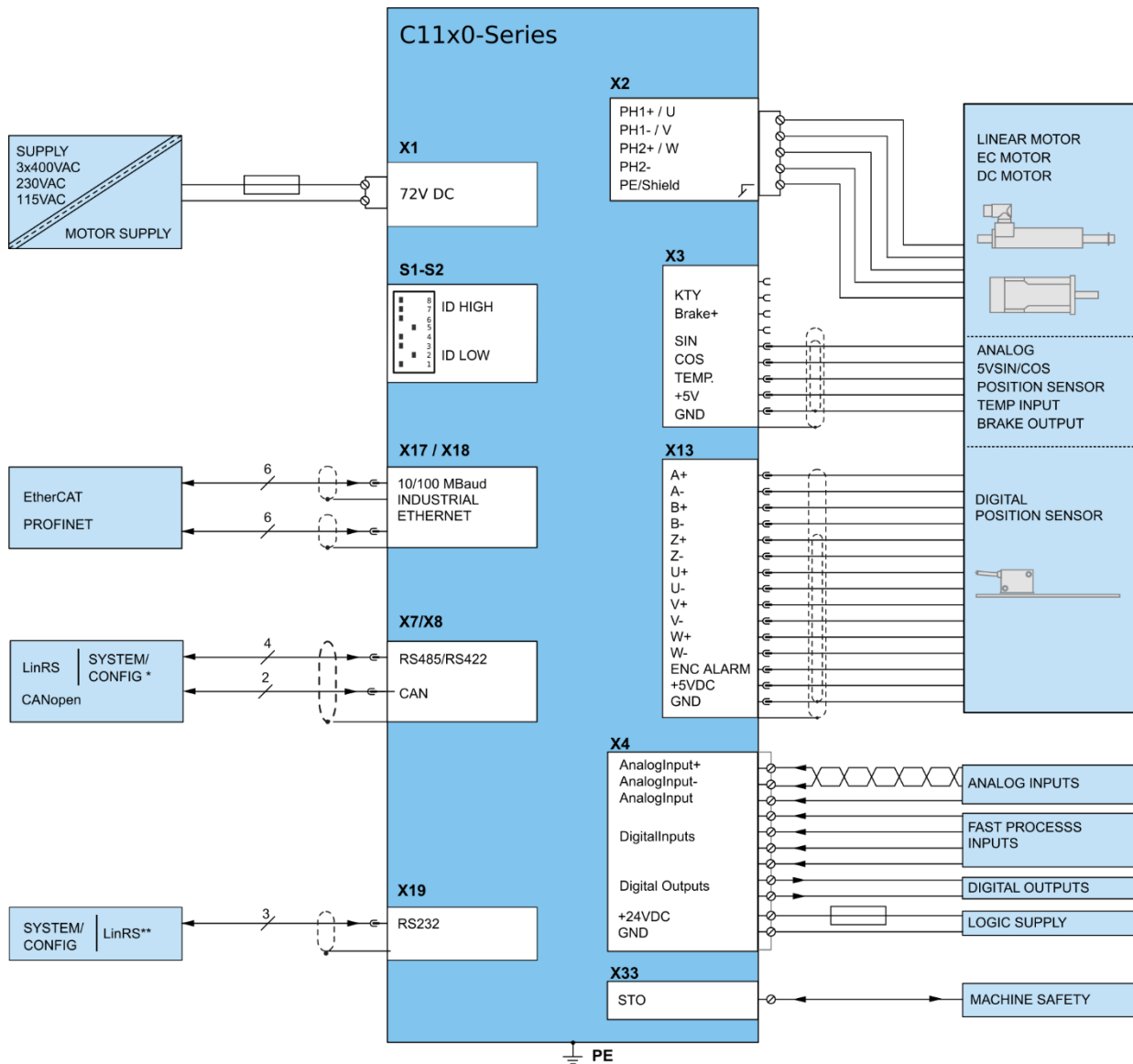

* LinRS if S4.1 is set to RS232, System/Config otherwise

** System/Config if S4.1 is set to RS232, LinRS otherwise

Figure 1: Typical servo system C11x0-XX: Servo drive, motor and power supply

3 Interfaces

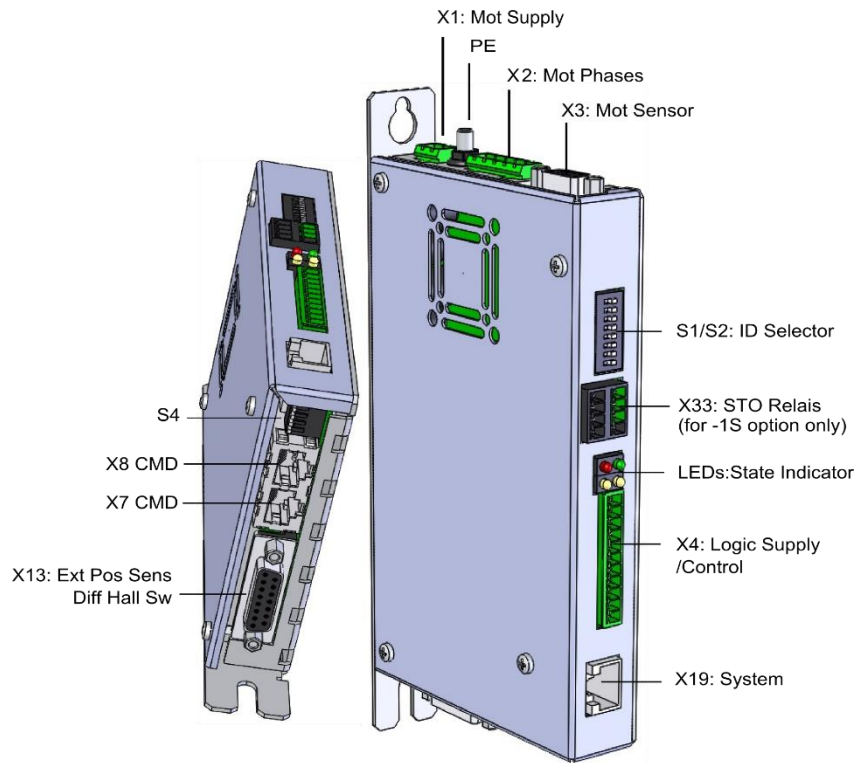

Figure 2: C1100-GP-XC-xS-xxx

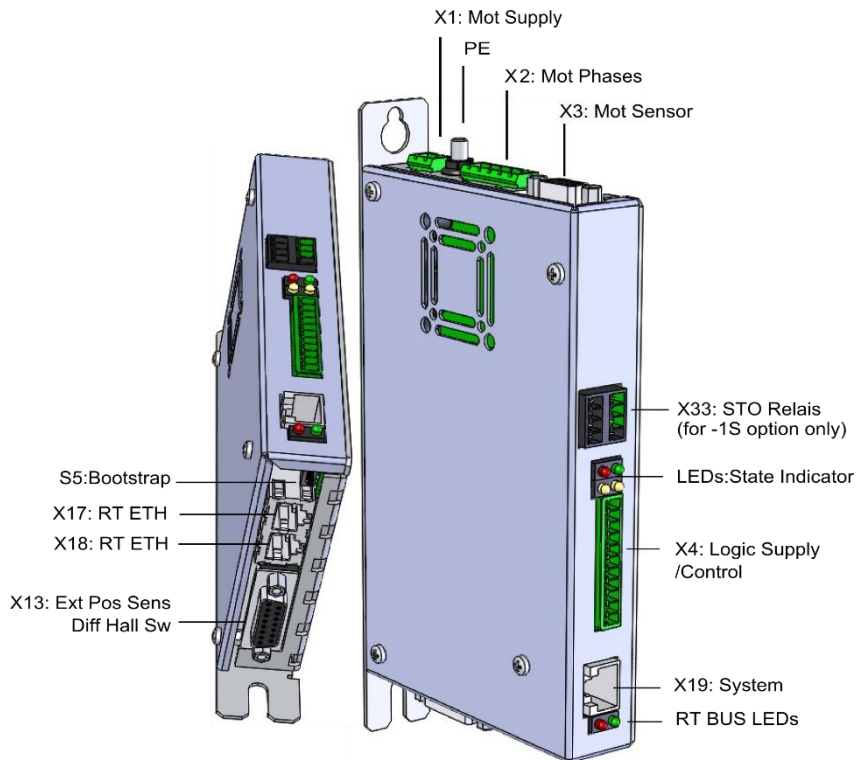

Figure 3: C1150-xx-XC-xS-xxx

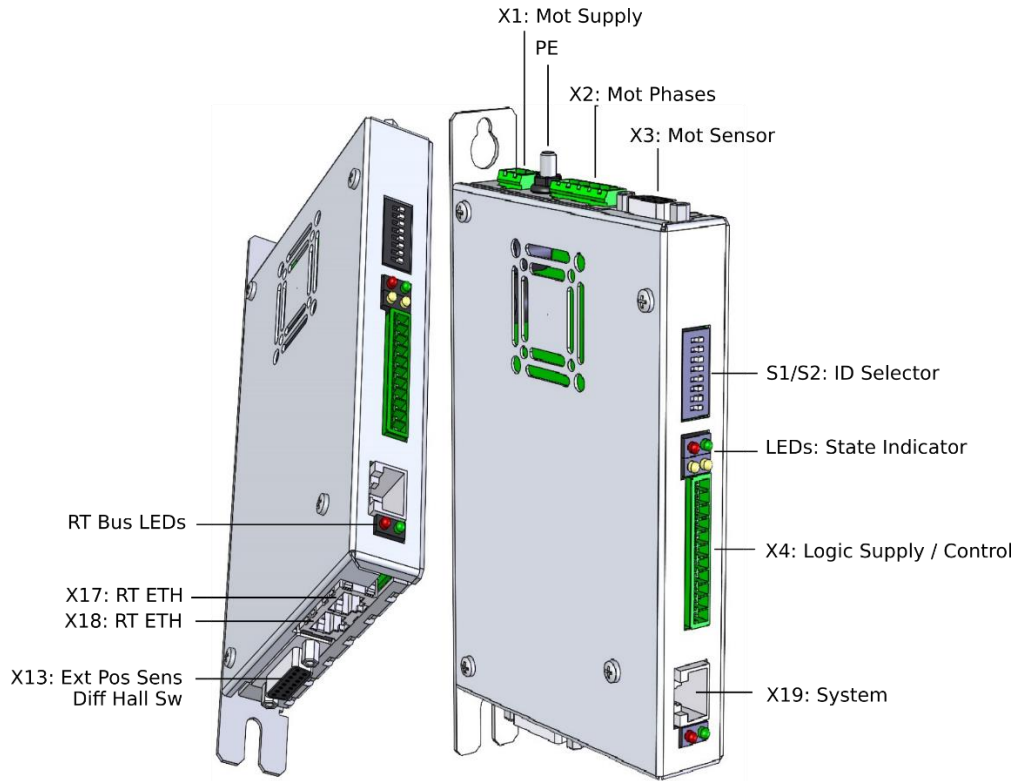

Figure 4: C1150-EC/DS/SE-XC-0S-xxx

4 Functionality

	C1100-GP-XC-0S	C1150-EC-XC-0S	C1150-DS-XC-0S	C1150-SE-XC-0S	C1150-PN-XC-0S	C1100-GP-XC-1S	C1150-EC-XC-1S	C1150-DS-XC-1S	C1150-SE-XC-1S	C1150-PN-XC-1S
Supply Voltage										
Motor Supply 72VDC (24...85 VDC)	•	•	•	•	•	•	•	•	•	•
Logic Supply 24VDC (22...26 VDC)	•	•	•	•	•	•	•	•	•	•
Motor Phase Current										
25A peak (0-599Hz)	•	•	•	•	•	•	•	•	•	•
Controllable Motors										
LinMot P01...(Motor Link P)	•	•	•	•	•	•	•	•	•	•
Selected motors (contact support)	•	•	•	•	•	•	•	•	•	•
Plug and Play (PnP) Auto Configuration	•	•	•	•	•	•	•	•	•	•
Command Interface										
RS485/RS422 up to 115.2 kBaud RS232 ****)	•					•				
CANOpen up to 1MBaud	•					•				
ETHERCAT LinMot Profile		•					•			
ETHERCAT CiA402			•					•		
ETHERCAT SoE				•					•	
PROFINET LinMot Profile					•					•
Address Selector (S1-S2)										
Address Selector 8 bit (S1-S2)	•	•***	•***	•***		•				
Programmable Motion Profiles (Curves)										
Up to 50 Motion Profiles, up to 8110 Curve Points	•	•	•	•	•	•	•	•	•	•
Programmable Command Table										
Command Table with up to 255 entries	•	•	•	•	•	•	•	•	•	•
External Position Sensor										
Incremental (RS422 < 10M counts/s)	•	•	•	•	•	•	•	•	•	•
Absolute (SSI*, BiSS-B**, BiSS-C**)	•	•	•	•	•	•	•	•	•	•
Panasonic (RS485)	•	•	•	•	•	•	•	•	•	•
Configuration Interface										
RS232 Configuration RS485/RS422 Configuration ****)	•	•	•	•	•	•	•	•	•	•
Integrated Safety Functions (-1S Option)										
STO (2 Safety Relays)						•	•	•	•	•

* since firmware version 6.6
 ** since firmware version 6.7
 *** since HW version V1RB3
 ****) since firmware version 6.9

5 Software

The configuration software LinMot-Talk is free of charge and can be downloaded from the LinMot homepage.

6 Power Supply and Grounding

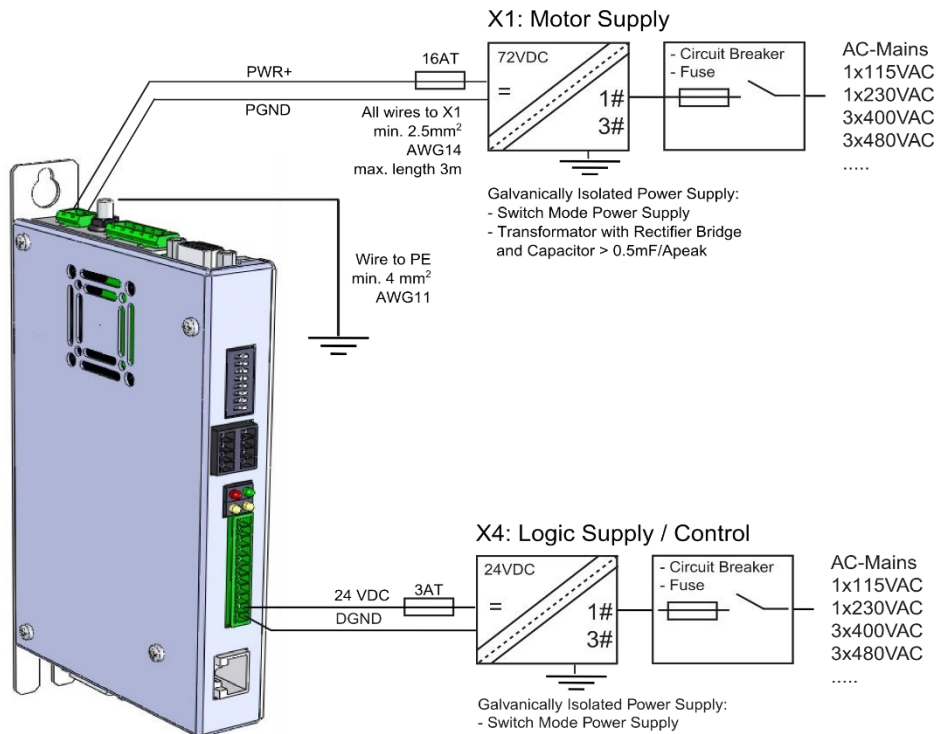

In order to assure a safe and error free operation, and to avoid severe damage to system components, **all system components must be well grounded to protective earth PE**. This includes both LinMot and all other control system components on the same ground bus.



Each system component¹ should be tied directly to the ground bus (**star pattern**). Daisy chaining from component to component is forbidden. (LinMot motors are properly grounded through their power cables when connected to LinMot drives.)



Power supply connectors must not be connected or disconnected while DC voltage is present. Do not disconnect system components until all LinMot drive LEDs have turned off. (Capacitors in the power supply may not fully discharge for several minutes after input voltage has been disconnected). Failure to observe these precautions may result in severe damage to electronic components in LinMot motors and/or drives.



Do not switch Power Supply DC Voltage. All power supply switching and E-Stop breaks should be done to the AC supply voltage of the power supply. Failure to observe these precautions may result in severe damage to the drive.

¹ Inside of the C1100 drive the *PWR* motor *GND* and *PWR* signal *GND* is connected together and to the *GND* of the drive housing. It is recommended that the *PWR* motor *GND* is NOT grounded at another place than inside of the drive to reduce circular currents.

7 Description of the connectors / Interfaces

7.1 PE

PE	Protective Earth
PE	<ul style="list-style-type: none"> Use min. 4mm² (AWG11) Tightening torque: 2Nm (18 lbin)

7.2 X1

X1	Motor Supply
	<p>PWR+</p> <p>PGND</p> <div style="border: 1px solid black; padding: 5px; width: fit-content; margin: 10px auto;"> <p>GND internally connected to controller housing which is connected to PE</p> </div>
<p>Connector has to be ordered separately: see chapter 14)</p>	<p>Motor Supply: 72VDC nominal (24...85VDC) Absolute max. Rating: 72VDC +20%. External Fuse: 16A slow blow / min. 100VDC If motor supply voltage exceeds 90VDC, the drive will go into error state.</p> <ul style="list-style-type: none"> Use 60/75° C copper conductors only Conductor Cross-Section 2.5mm² (AWG14) max Length 3m

7.3 X2/X3 Motor Connection

X2	Motor Phases																		
	<table border="1" style="width: 100%; border-collapse: collapse;"> <thead> <tr> <th></th> <th>LinMot Motor:</th> <th>3-phase EC-Motor:</th> </tr> </thead> <tbody> <tr> <td>PH1+</td> <td>Motor Phase 1+ red</td> <td>Motor Phase U red</td> </tr> <tr> <td>PH1</td> <td>Motor Phase 1- pink</td> <td>Motor Phase V pink</td> </tr> <tr> <td>PH2+</td> <td>Motor Phase 2+ blue</td> <td>Motor Phase W blue</td> </tr> <tr> <td>PH2-</td> <td>Motor Phase 2- grey</td> <td>(RR-)</td> </tr> <tr> <td>PE/SCRN</td> <td>PE</td> <td>PE</td> </tr> </tbody> </table>		LinMot Motor:	3-phase EC-Motor:	PH1+	Motor Phase 1+ red	Motor Phase U red	PH1	Motor Phase 1- pink	Motor Phase V pink	PH2+	Motor Phase 2+ blue	Motor Phase W blue	PH2-	Motor Phase 2- grey	(RR-)	PE/SCRN	PE	PE
	LinMot Motor:	3-phase EC-Motor:																	
PH1+	Motor Phase 1+ red	Motor Phase U red																	
PH1	Motor Phase 1- pink	Motor Phase V pink																	
PH2+	Motor Phase 2+ blue	Motor Phase W blue																	
PH2-	Motor Phase 2- grey	(RR-)																	
PE/SCRN	PE	PE																	
<p>Connector has to be ordered separately: see chapter 14)</p>	<ul style="list-style-type: none"> Use 60/75°C copper conductors only Conductor cross-section: 0.5 – 2.5mm² (depends on Motor current) / AWG 21 -14 PH2- could be used as RR- with 3 phase Motors the other side of regeneration resistor has to be wired to PWR+ 																		

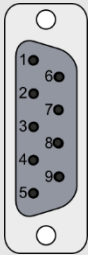
X3	Motor Sensor / Brake		LinMot Motor:	EC Motor:
	1		Do not connect	DGND, (Do not connect before Ver.1Rev.B1)
	2	6	Do not connect	Brake+
	3	7	Do not connect	+5VDC, (Do not connect before Ver.1Rev.B1)
	4	8	+5VDC	KTY
	5	9	DGND	+5VDC
			Sensor Sine	DGND
			Sensor Cosine	Sensor Sine / Hall Switch U
			Temp In	Sensor Cosine / Hall Switch V
	case		Shield	Hall Switch W
			Shield	Shield

DSUB-9 (f)

Note:

- Use +5V (X3.3) and AGND (X3.8) only for motor internal hall sensor supply (max. 100mA).
- The motor cable length must not exceed 30m.
- Brake+: 24V / max.500mA, Peak 1.4A (will shut down if bigger) the other terminal has to be wired to DGND (X3.1)

Caution:

- Do NOT connect DGND (X3.8) to ground or earth!

Temperature Sensor:

- A resistive temperature sensor (PT1000, KTY) could be connected between +5VDC (X3.2) and KTY (X3.7)

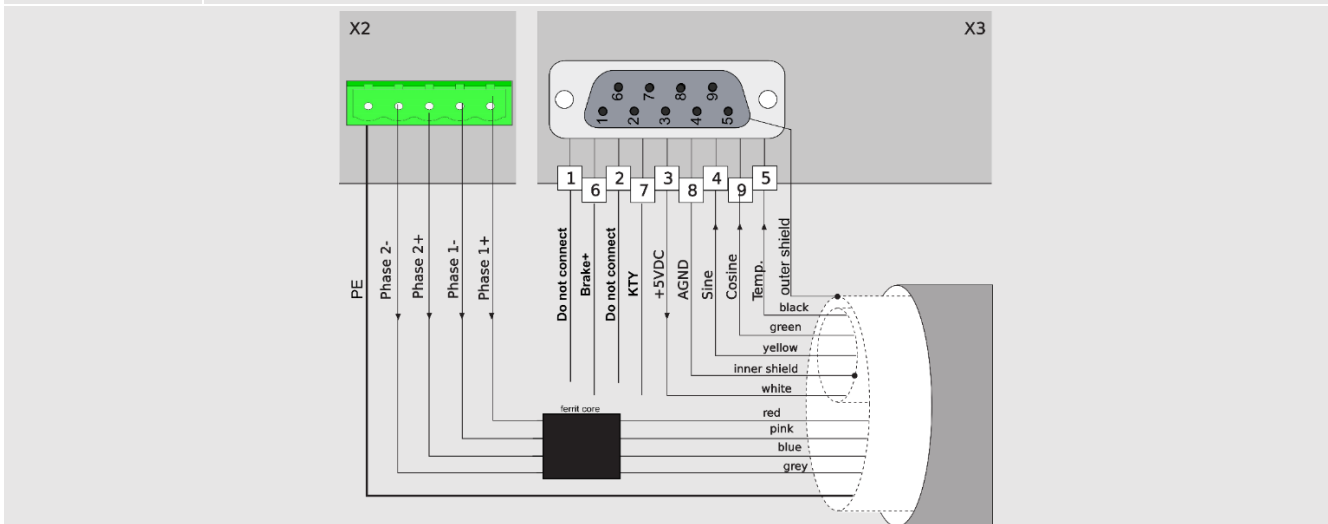

Important Notes:

- Use Y-style motor cables only (for example K15-Y/C)! A W-style cable has a different shielding, so it cannot be modified to a Y-style cable!
- The motor cable length must not exceed 30m.

7.4 X4

X4		Logic Supply / IO Connection		
	11	AnIn-	X4.11	Configurable differential analog Input (with X4.10)
	10	AnIn+	X4.10	Configurable differential analog Input (with X4.11)
	9	AnIn	X4.9	Configurable single ended analog Input
	8	In	X4.8	Configurable digital Input
	7	In	X4.7	Configurable digital Input
	6	In	X4.6	Configurable digital Input
	5	In	X4.5	Configurable digital Input
	4	Out	X4.4	Configurable digital Output
	3	Out	X4.3	Configurable digital Output
	2	+24VDC Supply		Logic Supply 22-26 VDC
	1	DGND	Supply	Ground
<p>DSUB-9 (f) Spring cage connector (has to be ordered separately: see chapter 14)</p>	<p>Inputs (X4.5 ... X4.8): 24V / 5mA (Low Level: -0.5 to 5VDC, High Level: 15 to 30VDC)</p> <p>Outputs (X4.3 & X4.4): 24V / max.500mA, Peak 1.4A (will shut down if exceeded) high-side switching with integrated pull-down (1k6 to DGND)</p> <p>Analog inputs: X4.9: 10 bit A/D converted Single ended analog input to DGND, 0..10V, Input Resistance: 51kΩ to DGND X4.10/X4.11: Differential analog input, +/- 10V. Common mode range: +/- 5VDC to DGND, Input Resistance 11.4kΩ for each signal to DGND.</p> <p>Mating connector (Art. Nr. 0150-3447):</p> <ul style="list-style-type: none"> • Use 60/75 °C copper conductors only • Conductor cross-section max. 1.5 mm² • Stripping length: 11.5 mm <p>Important notes: The 24 VDC logic supply for the control circuit (X4.2) must be protected with an external fuse (3 A slow blow)</p>			

7.5 X7 – X8

X7 – X8		RS485/CAN (on GP drives only)		
	1	RS485_Rx+	A	
	2	RS485_Rx-	B	
	3	RS485_Tx+	Y	
	4	NC		
	5	GND (1k Ohm to DGND)		
	6	RS485_Tx-	Z	
	7	CAN_H		
	8	CAN_L		
	case	Shield		
RJ-45	<p>Use twisted pair (1-2, 3-6, 4-5, 7-8) cable for wiring. The built in RS485 and CAN terminations can be activated by S4.2 and S4.3. X7 is internally connected to X8 (1:1 connection) Use isolated USB-RS485 converter (Art.-No. 0150-3356) for configuration over RS485</p>			

7.6 X13

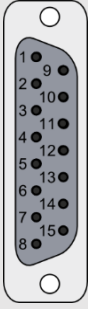
X13	External Position Sensor Differential Hall Switches		
		ABZ with Hall Switches	SSI* / BiSS-B** / BiSS-C**
	1	+5V DC	+5V DC
	9	A+	A+ (optional)
	2	A-	A- (optional)
	10	B+	B+ (optional)
	3	B-	B- (optional)
	11	Z+	Data+
	4	Z-	Data-
	12	Encoder Alarm (optional)	Encoder Alarm (optional)
	5	DGND	DGND
	13	U+	nc
	6	U-	nc
	14	V+	nc
	7	V-	nc
	15	W+	Clk+
	8	W-	Clk-
case	Shield	Shield	
DSUB-15 (f)	<p><u>Position Encoder Inputs (RS422):</u> Max. counting frequency: 10 Mcounts/s with quadrature decoding, 100ns minimal edge separation</p> <p><u>Differential Hall Switch Inputs (RS422):</u> Input Frequency: <1kHz</p> <p><u>Enc. Alarm In:</u> 5V / 1mA</p> <p><u>Sensor Supply:</u> 5VDC max 100mA (300mA since firmware version 6.7)</p>		
	* Since firmware version 6.6		
	** Since firmware version 6.7		

7.7 X17 – X18

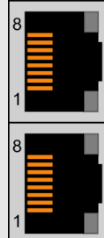
X17 – X18	RealTime Ethernet 10/100 Mbit/s (on EC and PN drives only)	
	X17 RT ETH In	Specification depends on RT Bus. Please refer to according documentation.
	X18 RT ETH Out	
RJ-45		

7.8 X19

X19	System	
	1	(Do not connect)
	2	(Do not connect)
	3	RS232 Rx
	4	GND
	5	GND
	6	RS232 Tx
	7	(Do not connect)
	8	(Do not connect)
	case	Shield
RJ-45	Use isolated USB-RS232 converter (Art.-No. 0150-2473) for configuration over RS232	

7.9 X33

X33	Safety Relays (only with the -1S option)		
X33.4/8 Ksr+ X33.3/7 Ksr- X33.2/6 Ksr f+ X33.1/5 Ksr f-		4 / 8 Ksr + 3 / 7 Ksr - 2 / 6 Ksr f+ 1 / 5 Ksr f-	Safety Relay 1 / 2 Input positive Safety Relay 1 / 2 Input negative Safety Relay 1 / 2 feedback positive Safety Relay 1 / 2 feedback negative
Spring cage connector (has to be ordered separately: see chapter 14)	- Use 60/75°C copper conductors only - Conductor cross-section max. 1.5mm ² - Stripping length: 10mm		
	- Never connect the safety relays to the logic supply of the drive! → For detailed information see chapter 9 Safety Wiring.		

7.10 S1 – S2

S1 – S2	Address Selectors	
	S1 (5..8)	Bus ID High (0 ... F). Bit 5 is the LSB, bit 8 the MSB.
	S2 (1..4)	Bus ID Low (0 ... F). Bit 1 is the LSB, bit 4 the MSB.
	Setting the ID high & low to 0xFF resets the drive to manufacturer settings!	
	The use of these switches depends on the type of fieldbus which is used. Please see the corresponding manual for further information.	
Note	The address selectors are available on the following drives: <ul style="list-style-type: none"> - C1100-GP-XC-0S, all versions - C1100-GP-XC-1S, all versions - C1150-EC-XC-0S, from version V1RB3 - C1150-DS-XC-0S, from version V1RB3 - C1150-SE-XC-0S, from version V1RB3 	

7.11 S4

S4	Bus Termination (on GP drives only)	
	S4	Switch 4: Bootstrap Switch 3: Termination CAN on/off Switch 2: Termination RS485 on/off Switch 1: Config: off = RS232, on = RS485 Factory settings: Switch 3 "on", all other switches "off"

7.12 S5

S5	Bootstrap (on EC and PN drives only)	
	S5	Bootstrap (Internal use only)

7.13 LEDs

LEDs	State Displays		
	Signal: 24VOK	Color: Green	Description: 24V Logic Supply OK
	EN	Yellow	Motor Enabled / Error Code Low Nibble
	Warn	Yellow	Warning / Error Code High Nibble
	Error	Red	Error

7.14 RT Bus LEDs

RT Bus LEDs	RT Bus State Display		
	Signal: OK	Color: Green	Description: OK
	RT BUS ERROR	Red	Error
The use of these LEDs depends on the type of fieldbus which is used. Please see the corresponding manual for further information			

8 LED Blink Codes

LED Blink Codes			
Error			24VOK
Warn			EN
Error	Warn	EN	Description
Off	Warning	Operation Enabled	Normal Operation: Warnings and operation enabled are displayed.
On	<ul style="list-style-type: none"> • ~2Hz 0..15 x Error Code High Nibble 	<ul style="list-style-type: none"> • ~2Hz 0..15 x Error Code Low Nibble 	Error: The error code is shown by a blink code with "WARN" and "EN" The error byte is divided into low and high nibble (= 4 bit). "WARN" and "EN" are blinking together. The error can be acknowledged. (e.g.: WARN blinks 3x, EN blinks 2x; Error Code = 32h)
<ul style="list-style-type: none"> • ~2Hz 	<ul style="list-style-type: none"> • ~2Hz 0..15 x Error Code High Nibble 	<ul style="list-style-type: none"> • ~2Hz 0..15 x Error Code Low Nibble 	Fatal Error: The error code is shown by a blink code with "WARN" and "EN". The error byte is divided into low and high nibble. "WARN" and "EN" are blinking together. Fatal errors can only be acknowledged by a reset or power cycle. (e.g.: WARN blinks 3x, EN blinks 2x; Error Code = 32h)
<ul style="list-style-type: none"> • ~4Hz 	<ul style="list-style-type: none"> • ~2Hz 0..15 x Error Code High Nibble 	<ul style="list-style-type: none"> • ~2Hz 0..15 x Error Code Low Nibble 	System Error: Please reinstall firmware or contact support.
<ul style="list-style-type: none"> • ~0.5Hz 	<ul style="list-style-type: none"> • ~0.5Hz 	On	Signal Supply 24V too low: The error and warn LEDs blink alternating if the signal supply +24V (X4.2) is less than 18VDC.
Off	○○○	●○○	Plug&Play Communication Active: This sequence (Warn on, then En on, then both off, complete sequence of the 4 states ca. 1Sec) signals the state when the plug and play parameters are being read from the motor.
<ul style="list-style-type: none"> ○● ~4Hz 	<ul style="list-style-type: none"> ●○ ~4Hz 	Off	Waiting for Defaulting Parameters: When ID (S1, S2) is set to 0xFF, the drive starts up in a special mode and the Error and Warn LED blink alternating ~4Hz. When the ID is set to 0x00, all parameters will be set to their default value. To leave this state, power down the drive and change the ID. Also see in the Usermanual_LinMot-Talk under chapter trouble shooting.
Off	<ul style="list-style-type: none"> ○● ~2Hz 	<ul style="list-style-type: none"> ○● ~2Hz 	Defaulting Parameters Done: When the parameters have set to their default values (initiated via S1/S2 on power up) the Warn and En LEDs blink together at 2 Hz. To leave this state, power down the drive. Also see in the Usermanual_LinMot-Talk under chapter trouble shooting.
Off	Off	Off	Bootstrap The drive is in the bootstrap mode if the two RT LEDs are also off (if present). Switch S5 or S4.4 (GP) off.

The meaning of the error codes can be found in the *Usermanual_MotionCtrl_Software_SG5* and the user manual of the installed interface software. These documents are provided together with LinMot-Talk configuration software and can be downloaded from www.linmot.com.

9 Safety Wiring

The C1100 drives with the -1S option have internal safety functions: Two Safety relays Ksr in series, which support the supply voltage for the motor drivers. There are also two feedback contacts for each relay.

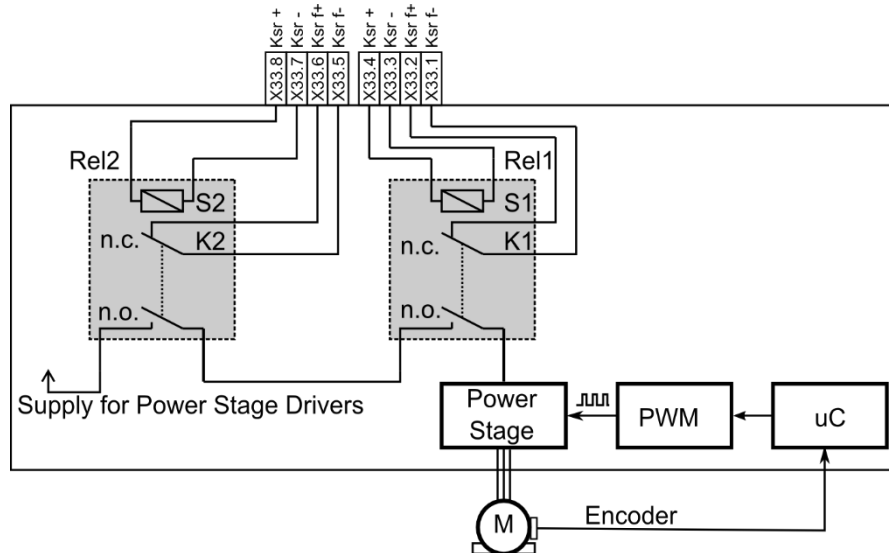

To enable the -1S drives both relays have to be switched on.

Minimal wiring:

- Connect X33.8 and X33.4 to 24VDC (from safety)
- Connect X33.7 and X33.3 to GND (from safety)



Never connect X33.8 and X33.4 to the logic supply of X4!



Overvoltage protection must be provided externally and sized according the safety circuit of the machine!



The drop out time of the relays is depending on the external circuitry!

Safety Relay Ksr	
Nominal voltage	24 VDC
Min. pick-up voltage at 20°C	≤ 16.8V
Drop-out voltage at 20°C	≥ 2.4 V
Drop-out time (no protection circuit)	Typ. 3ms
Coil resistance at 20°C	2'100 Ω ± 10%
Type	EN 50205, type A
Contact lifetime	> 10'000'000
Manufacturer and type	Elesta relays / SIS112 24VDC

Drive Classification according EN ISO 13849-1 (safety of machinery)	
Category	cat = 3
Performance Level	PL = d
Diagnostic Coverage	DC = high (99%)
Mean Time to hazardous failure of one channel	MTTF _d = high (100 years typically, see calculation example below)

DC (Diagnostic Coverage) is high (99%) assuming that the state of the feedback contacts is checked after each change of the state of the control contacts.

MTTF_d mainly depends on the number of operations of the safety relays.

Example calculation of MTTF_d:

Assuming that the safety function is requested every 20s on a machine running 24h per day and 7 days per week.

$$B_{10} = 10'000'000$$

$$B_{10d} = 20'000'000 \text{ (according EN ISO 13849-1:2008 table C.1)}$$

$$n_{op} = (24h/Tag * 365.25Tage/Jahr * 3600s/h) / 20s = 1'577'880 \text{ operations per year}$$

$$MTTF_d = B_{10d} / (0.1 \times n_{op}) = 126.75 \text{ years}$$

(This has to be limited to 100years according the standard for further calculations)

$$= \text{high (100 years)}$$

10 Physical Dimension

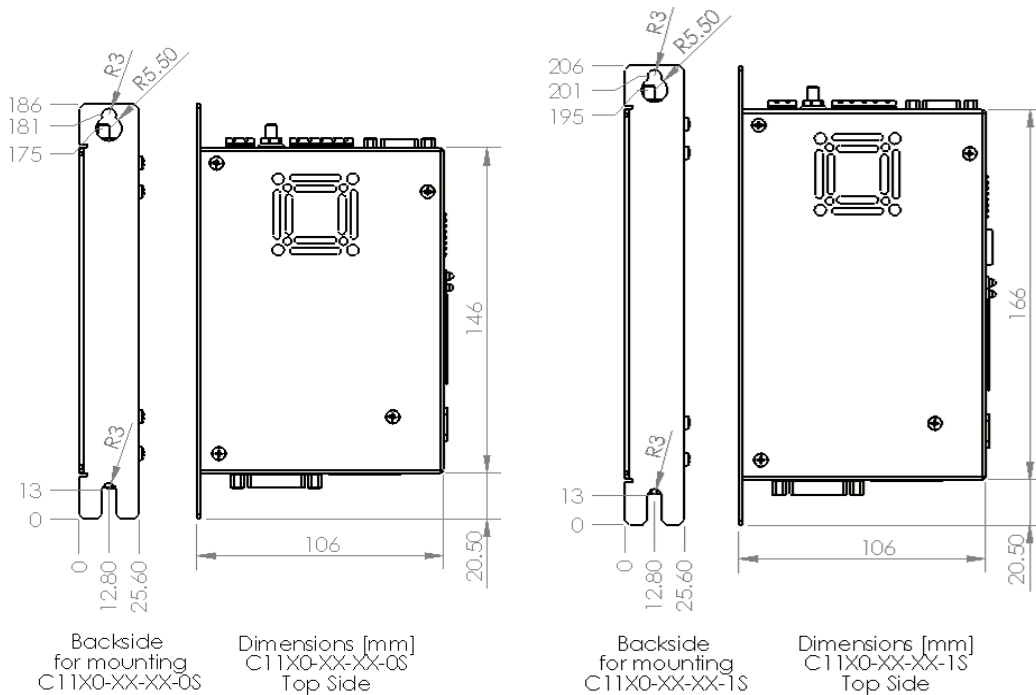

C1100 Series single axis drive		C11xx-xx-XC-0S	C11xx-xx-XC-1S
Width	mm (in)	25.6 (1.01)	
Height	mm (in)	146 (5.75)	166 (6.54)
Height with fixings	mm (in)	186 (7.3)	206 (8.1)
Depth	mm (in)	106 (4.2)	
Weight	g (lb)	550 (1.21)	650 (1.43)
Mounting Screws		2 x M5	2 x M5
Mounting Distance	mm (in)	168 (6.61)	188 (7.4)
Case	IP	20	
Storage Temperature	°C	-25...40	
Transport Temperature	°C	-25...70	
Operating Temperature	°C	0...40 at rated data 40...50 with power derating	
Relative humidity		95% (non-condensing)	
Pollution	IEC/EN 60664-1	Pollution degree 2	
Shock resistance (16ms)	-1S option		3.5g
Vibration resistance (10-200Hz)	-1S option		1g
Max. Case Temperature	°C	70	
Max. Power Dissipation	W	30	
Mounting place		In the control cabinet	
Mounting position		vertical	
Distance between Drives	mm (in)	Without Power Derating: 20 (0.8) horizontal / 50 (2) vertical With Power Derating: 5 (0.2) horizontal / 20 (0.8) vertical	

* The derating is depending on the situation in the cabinet. The temperature of the drive should be checked under full load (the temperature should be stable, which may take an hour or more). This allows to verify that enough margin is there if the cabinet goes to the maximum allowable temperature of 40° C. For example, if the drive temperature reaches 45° C and the cabinet temperature is 30° C, this would result in a drive temperature of about 55° C at a cabinet temperature of 40° C. The warning level of the drive is configured by default to 75° C and the error level to 80° C. In this example, everything is fine. If the drive temperature is long time above the warning level, this might result in a reduced lifetime of the drive

11 Power Supply Requirements

11.1 Motor Power Supply

The calculation of the needed power for the Motor supply is depending on the application and the used motor. The nominal supply voltage is 72VDC. The possible range is from 24 to 85VDC.



The motor supply can rise up to 95 VDC when braking. This means that everything connected to that power supply needs a voltage rating of 100 VDC. (Additional capacitors, etc...). Due to high braking voltage and sudden load variations of linear motor applications, **only compatible power supplies can be used (see chapter 14 Ordering Information).**

11.2 Signal Power Supply

The logic supply needs a regulated power supply of a nominal voltage of 24 VDC. The voltage must be between 22 and 26 VDC.

Current consumption:

- min. 0.3A (no load on the outputs)
- typ. 0.5A (all 2 outputs "on" with 100mA load and /Brake with no load)
- max. 1.5A (all 2 outputs "on" with 370mA peak load and /Brake with 370mA peak load)



**Do not connect the safety relays to the 24VDC Signal Supply!
Use a separate power supply for the safety circuit**



The 24VDC supply for the control circuit must be protected with an external fuse (3A slow blow)

12 Regeneration Resistor

If the power supply rises too high when braking, connect an additional capacitor to the motor power supply. It is recommended to use a capacitor $\geq 10'000 \mu\text{F}$ (install capacitor close to the drive supply!). With 3 phase motors also a regeneration resistor is supported on X2 (Ph2-).

13 Safety notes for the installation according UL

Markings:

- **Wiring terminal markings:**
See markings on the enclosure and the corresponding chapters in the installation guide!
- **Cautionary Marking:**
See markings on the enclosure and the corresponding chapters in the installation guide!
- **Motor overload protection must be provided externally in the end-use.** Motor Overload protection can alternatively be provided when the connected motor has a thermal sensor rated 5V DC, max. 100mA which is connected to the drive thermal sensor input (X3). (The LinMot P01-Motors are therefore protected by the drive)
- The transients have to be limited to max. 0.8kV on the line side of the drive.
- The 24VDC supply for the control circuit must be protected with an external UL Listed 3A DC Fuse.
- Proposed ratings, to be evaluated in the end-use:
 - Input Voltage: 72VDC
 - Input current: 15A
 - Output Voltage: 61.5V rms
 - Output Current: 17.7A rms max.
 - Number of Phases: 2 by 1 Phase
 - Frequency range: 0-500Hz
 - Duty cycle rating: 10%
 - Relays (only for -1S variant):
 - Rated Contacts: max. 24VDC 6A.
 - Coil: 24VDC
 - Surrounding air temp: max. 85°C
 - Control Power (X4-2): 24VDC (Protected with an external UL Listed 3A DC Fuse)
 - Surrounding Air Temperature: max. 50°C
- **A separate 24VDC power supply protected with an external UL Listed 3A DC Fuse connected to the output of the power supply must be used to protect the secondary control circuit (safety relays on X33)**

14 Ordering Information

Drive	Description	Art. No.
C1100-GP-XC-0S-000	General Purpose Drive 72VDC/25Apeak	0150-2380
C1150-EC-XC-0S-000	ETHERCAT Drive 72VDC/25Apeak	0150-2382
C1150-DS-XC-0S-000	ETHERCAT CiA402 Drive 72VDC/25Apeak	0150-2417
C1150-SE-XC-0S-000	ETHERCAT SoE Drive 72VDC/25Apeak	0150-2625
C1150-PN-XC-0S-000	PROFINET Drive 72VDC/25Apeak	0150-2384
C1100-GP-XC-1S-000	General Purpose Drive 72VDC/25Apeak/STO	0150-2381
C1150-EC-XC-1S-000	ETHERCAT Drive 72VDC/25Apeak/STO	0150-2383
C1150-DS-XC-1S-000	ETHERCAT CiA402 Drive 72VDC/25Apeak/STO	0150-2418
C1150-SE-XC-1S-000	ETHERCAT SoE Drive 72VDC/25Apeak/STO	0150-2626
C1150-PN-XC-1S-000	PROFINET Drive 72VDC/25Apeak/STO	0150-2385
Accessories	Description	Art. No.
DC01-C1X00-0S/X1/X4	Drive Connector Set for C1X00-0S	0150-3527
DC01-C1X00-1S/X1/X4/X33	Drive Connector Set for C1X00-1S	0150-3528
DC01-C1X00/X1	Drive Connector for PWR 72VDC Input	0150-3525
DC01-C1X00/X2	Drive Connector Motor Phases	0150-3526
DC01-Signal/X4	Drive Connector 24VDC & Logic	0150-3447
DC01-Safety/X33	Drive Connector Safety	0150-3451
Isolated USB-RS232 converter	Isolated USB RS232 converter with config. cable	0150-2473
RS232 PC config. Cable 2.5m	For C1100/C1250/E1200/E1400/M8000	0150-2143
Isolated USB-serial converter	Isolated USB RS232/422/485 converter	0150-3120
AS01-X4-DIP-SW-000	6 pole DIP switch for C1100-EC, on X4	0150-2498
Compatible Power Supplies		Art. No.
S01-24/500	Power Supply 24V/500W, 1x120/230VAC	0150-2480
S01-48/300	Power Supply 48V/300W, 1x120/230VAC	0150-1941
S01-48/600	Power Supply 48V/600W, 1x120/230VAC	0150-1946
S01-72/500	Power Supply 72V/500W, 1x120/230VAC	0150-1874
S01-72/1000	Power Supply 72V/1000W, 3x340-550VAC	0150-1872
S02-72/1000	Power Supply 72V/1000W, 3x400-480VAC	0150-4535
T01-72/420-Multi	T-Supply 72V/420VA, 3x230/400/480VAC	0150-1869
T01-72/900-Multi	T-Supply 900VA, 3x230/400/480 VAC	0150-1870
T01-72/1500-Multi	T-Supply 1500VA, 3x230/400/480 VAC	0150-1871
T01-72/420 -1ph	T-Supply 420VA, 1x208/220/230/240VAC	0150-1859

Bold items are strongly recommended accessories!





The connectors have to be ordered separately and are not included with the drive!



Use isolated USB RS232 converter for configuration!

15 International Certifications

Certifications	
<p>Europe</p> 	<p>See chapter 16 EU Declaration of Conformity CE-Marking</p>
<p>UK</p> 	<p>See chapter 17 UK Declaration of Conformity UKCA-Marking</p>
<p>IECEE CB SCHEME</p>	<p>Ref. Certif. No. CH-7684</p>
<p>USA / Canada</p> 	<p>All products marked with this symbol are tested and recognized by Underwriters Laboratories and the production facilities are checked quarterly by an UL inspector. This mark is valid for the USA and Canada and eases certification of your machines and systems in these areas.</p> <p>File number E316095 UL 508C Power Conversion Equipment CSA C22.2 Industrial Control Equipment</p>

	Ref. Certif. No.
	CH-7684

IEC SYSTEM FOR MUTUAL RECOGNITION OF TEST CERTIFICATES FOR ELECTRICAL EQUIPMENT (IECEE) CB SCHEME		SYSTEME CEI D'ACCEPTATION MUTUELLE DE CERTIFICATS D'ESSAIS DES EQUIPMENTS ELECTRIQUES (IECEE) METHODE OC	
CB TEST CERTIFICATE / CERTIFICAT D'ESSAI OC			
Product Produit	Servo drive unit		
Name and address of the applicant Nom et adresse du demandeur	NTI AG	Linmot Haerdlistrasse 15 CH-8957 Spreitenbach	Switzerland
Name and address of the manufacturer Nom et adresse du fabricant	NTI AG	Linmot Haerdlistrasse 15 CH-8957 Spreitenbach	Switzerland
Name and address of the factory Nom et adresse de l'usine	NTI AG	Linmot Haerdlistrasse 15 CH-8957 Spreitenbach	Switzerland
Note: When more than one factory, please report on page 2 Note: Lorsque il y plus d'une usine, veuillez utiliser la 2 ^{ème} page	<input type="checkbox"/> Additional Information on page 2		
Ratings and principal characteristics Valeurs nominales et caractéristiques principales	Motor supply	72 VDC (24 – 85 VDC), 15 A	
	Logic supply	24 VDC (22 – 26 VDC), 3 A	
	Class I		
Trade mark (if any) Marque de fabrique (si elle existe)	LinMot		
Type of Manufacturer's Testing Laboratories used Type de programme du laboratoire d'essais constructeur	---		
Model / Type Ref. Ref. de type	C1150 Servo Drive / C1150-EC-XC-1S-000		
Additional information (if necessary may also be reported on page 2) Les informations complémentaires (si nécessaire, peuvent être indiqués sur la 2 ^{ème} page)	---		
A sample of product was tested and found to be in conformity with IEC Un échantillon de ce produit a été essayé et a été considéré conforme à la CEI	<input checked="" type="checkbox"/> Additional Information on page 2		
National differences / Comments Les différences nationales / Commentaires	61000-6-2(ed.2) 61000-6-4(ed.2);am1		
As shown in the Test Report Ref. No. which forms part of this Certificate Comme indiqué dans le Rapport d'essais numéro de référence qui constitue partie de ce Certificat	EU Group Differences; EU Special National Conditions; EU A-Deviations 14-IK-0141.E02		

This CB Test Certificate is issued by the National Certification Body
Ce Certificat d'essai OC est établi par l'Organisme National de Certification

Electrosuisse
Luppenstrasse 1,
CH-8320 Fehraltorf

Signed by: Martin Plüss
2014-12-04

page 1 of 2



Ref. Certif. No.

CH-7684

Additional information (if necessary)
Information complémentaire (si nécessaire)

Type list

Type	Model number	Ratings	
C1100-GP-XC-0S-000	0150-2380	General Purpose Drive	72 VDC/25 A peak
C1150-EC-XC-0S-000	0150-2382	ETHERCAT Drive	72 VDC/25 A peak
C1150-DS-XC-0S-000	0150-2417	ETHERCAT CiA402 Drive	72 VDC/25 A peak
C1150-SE-XC-0S-000	0150-2625	ETHERCAT SoE Drive	72 VDC/25 A peak
C1150-PN-XC-0S-000	0150-2384	PROFINET Drive	72 VDC/25 A peak
C1100-GP-XC-1S-000	0150-2381	General Purpose Drive	72 VDC/25 A peak/STO
C1150-EC-XC-1S-000	0150-2383	ETHERCAT Drive	72 VDC/25 A peak/STO
C1150-DS-XC-1S-000	0150-2418	ETHERCAT CiA402 Drive	72 VDC/25 A peak/STO
C1150-SE-XC-1S-000	0150-2626	ETHERCAT SoE Drive	72 VDC/25 A peak/STO
C1150-PN-XC-1S-000	0150-2385	PROFINET Drive	72 VDC/25 A peak/STO

Nomenclature

Code	Description
C1100-	Drive type (Equipment containing Ethernet has an xxx50)
GP-	Interface
LC-	Power output
0S-	Functional safety option
000	Individual extension (e.g. customer related firmware option etc.)

Interfaces			Power output	
Code	Abbr.	Description	Code	Description
0	GP	General Purpose	LC	8 A peak
0	CO	CANopen	HC	15 A peak
0	DN	DeviceNet	XC	25 A peak
10	VF	Velocity and Force	UC	32 A peak
30	DP	PROFIBUS DP		
50	EC	ETHERCAT		
50	PN	ProfiNet		
50	SE	SERCOS over ETHERCAT		
50	PL	POWERLINK		
50	PN	Profinet		
50	PD	Profinet mit Profidrive		
50	IP	ETHERNET IP		
50	SC	SERCOS III		

This CB Test Certificate is issued by the National Certification Body
Ce Certificat d'essai OC est établi par l'Organisme National de Certification

Electrosuisse
Luppenstrasse 1,
CH-8320 Fehraltorf

Signed by: Martin Plüss
2014-12-04



CERTIFICATE OF COMPLIANCE

Certificate Number 20140317-E316095
Report Reference E316095-20140307
Issue Date 2014-March-17

Issued to: NTI AG
 HAERDLISTRASSE 15,
 8957 SPREITENBACH SWITZERLAND



This is to certify that representative samples of COMPONENT - POWER CONVERSION EQUIPMENT
 SEE ADDENDUM PAGE FOR MODELS

Have been investigated by UL in accordance with the Standard(s) indicated on this Certificate.

Standard(s) for Safety: UL 508C - Power Conversion Equipment
 CSA C22.2 NO. 14-13- INDUSTRIAL CONTROL EQUIPMENT.

Additional Information: See the UL Online Certifications Directory at www.ul.com/database for additional information

Only those products bearing the UL Recognized Component Marks for the U.S. and Canada should be considered as being covered by UL's Recognition and Follow-Up Service and meeting the appropriate U.S. and Canadian requirements.

The UL Recognized Component Mark for the U.S. generally consists of the manufacturer's identification and catalog number, model number or other product designation as specified under "Marking" for the particular Recognition as published in the appropriate UL Directory. As a supplementary means of identifying products that have been produced under UL's Component Recognition Program, UL's Recognized Component Mark:  may be used in conjunction with the required Recognized Marks. The Recognized Component Mark is required when specified in the UL Directory preceding the recognitions or under "Markings" for the individual recognitions. The UL Recognized Component Mark for Canada consists of the UL Recognized Mark for Canada:  and the manufacturer's identification and catalog number, model number or other product designation as specified under "Marking" for the particular Recognition as published in the appropriate UL Directory.

Recognized components are incomplete in certain constructional features or restricted in performance capabilities and are intended for use as components of complete equipment submitted for investigation rather than for direct separate installation in the field. The final acceptance of the component is dependent upon its installation and use in complete equipment submitted to UL LLC.

Look for the UL Recognized Component Mark on the product.

William R. Carney, Director, North American Certification Programs
 UL LLC

Any information and documentation involving UL Mark services are provided on behalf of UL LLC (UL) or any authorized licensee of UL. For questions, please contact a local UL Customer Service Representative at www.ul.com/contact



CERTIFICATE OF COMPLIANCE

Certificate Number 20140317-E316095
Report Reference E316095-20140307
Issue Date 2014-March-17

This is to certify that representative samples of the product as specified on this certificate were tested according to the current UL requirements.

Open type Power Conversion Equipment Models:

- Model A, may be followed by P, followed by 11, followed by 00, 30 or 50, followed by -, followed by GP, PL, PN, SC, IP, EC, SE, PD, DP, VA, CO, CD, DN, DS, CM, or LU, followed by -, followed by LC, followed by -0S, may be followed by - and any characters.

- Model C, may be followed by P, followed by 11 or 12, followed by 00, 30 or 50, followed by -, followed by GP, PL, PN, SC, IP, EC, SE, PD, DP, VA, CO, CD, DN, DS, CM, or LU, followed by -, followed by XC, followed by -0S or -1S, may be followed by - and any characters.

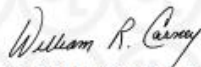

William R. Carney, Director, North American Certification Programs
UL LLC

Any information and documentation involving UL Mark services are provided on behalf of UL LLC (UL) or any authorized licensee of UL. For questions, please contact a local UL Customer Service Representative at www.ul.com/contactus.



16 EU Declaration of Conformity CE-Marking

NTI AG / LinMot ®
Bodenaeckerstrasse 2
8957 Spreitenbach
Switzerland
Tel.: +41 56 419 91 91

declares under sole responsibility the compliance of the products:

- Drives of the Series **C11x0-xx-XC-xS-xxx**

with the **EMC Directive 2014/30/EU**.

Applied harmonized standards:

- **EN 61000-6-2: 2005 (Immunity for industrial environments)**
- **EN 61000-6-4: 2007 + A1:2011 (Emission for industrial environments)**

According to the EMC directive, the listed devices are not independently operable products.

Compliance of the directive requires the correct installation of the product, the observance of specific installation guides and product documentation. This was tested on specific system configurations.

The safety instructions of the manuals are to be considered.

These products are intended for installation in machines. Operation is prohibited until it has been determined that the machines in which these products are to be installed, conforms to the above mentioned EC directive.

The product must be mounted and used in strict accordance with the installation instructions contained within the installation guide, a copy of which may be obtained from NTI AG.

Company: NTI AG
Spreitenbach, 11.04.2016



Dr. Ronald Rohner / CEO NTI AG

17 UK Declaration of Conformity UKCA-Marking

NTI AG / LinMot ®
Bodenaeckerstrasse 2
8957 Spreitenbach
Switzerland
Tel.: +41 (0)56 419 91 91
Fax: +41 (0)56 419 91 92

declares under sole responsibility the compliance of the products:

- Drives of the Series **C11x0-xx-XC-xS-xxx**

with the EMC Regulation S.I. 2016 No. 1091.

Applied designated standards:

- **EN 61000-6-2: 2005 (Immunity for industrial environments)**
- **EN 61000-6-4: 2007 +A1:2011 (Emission for industrial environments)**

According to the EMC regulation, the listed devices are not independently operable products.

Compliance of the regulation requires the correct installation of the product, the observance of specific installation guides and product documentation. This was tested on specific system configurations.

The safety instructions of the manuals are to be considered.

The product must be mounted and used in strict accordance with the installation instructions contained within the installation guide, a copy of which may be obtained from NTI AG.

Company: NTI AG
Spreitenbach, 23.03.2022



Dr. Ronald Rohner / CEO NTI AG

18 Contact & Support

Europe / Asia Headquarters

NTI AG - LinMot & MagSpring
Bodenaeckerstrasse 2
CH-8957 Spreitenbach
Switzerland

Sales / Administration: +41 56 419 91 91
office@linmot.com

Tech. Support: +41 56 544 71 00
support@linmot.com

Web: <https://www.linmot.com>

North / South America Headquarters

LinMot USA Inc.
N1922 State Road 120, Unit 1
Lake Geneva, WI 53147
USA

Sales / Administration: 262.743.2555
usasales@linmot.com

Tech. Support: 262.743.2555
usasupport@linmot.com

Web: <https://www.linmot-usa.com>

Visit <https://www.linmot.com/contact> to find a distributor next to you.

Smart solutions are...

