

Servo Drive B1100**Series B1100-PP****288****Series B1100-VF****290****Series B1100-GP****292**

Servo Drives B1100

Series B1100 Servo Drives are compact axis drives, with 32-bit position resolution and an integrated power element, for linear motors and rotary drives.

The drives are suitable for simplest and standard positioning tasks, across the entire force range of the LinMot product range.



Connection to Machine Drive

The Series B1100 Servo Drives can be actuated by machine controls from any manufacturer or brand, via digital inputs and outputs; by RS232 or RS485 serial interface; or by CanBus CANopen and DeviceNet interfaces.

For complex motion sequences that run in an overarching positioning drive, the motor can be controlled by means of analog speed or force targets. The position signal from the measurement system integrated in the linear motor can be accessed at the encoder output to control position.

Process and sensor interfaces

Fast process interfaces for direct processing of sensor signals are available as freely programmable analog and digital inputs and fast trigger inputs.

For high-accuracy applications, a freely configurable encoder interface is available. It analyzes the commutation signals from brushless, rotary servomotors as well.

Logic and power supply

The Servo Drives have two separate power supplies for the logic and power elements.

In an E-stop and safe stop of the drive, only the power element supply is cut off from the drive. The logic supply and the drive continue to run.

This has the advantage that the drive and linear motor do not need to be reinitialized when the machine is restarted, since all process data, including the current position of the linear motor, are still up to date.

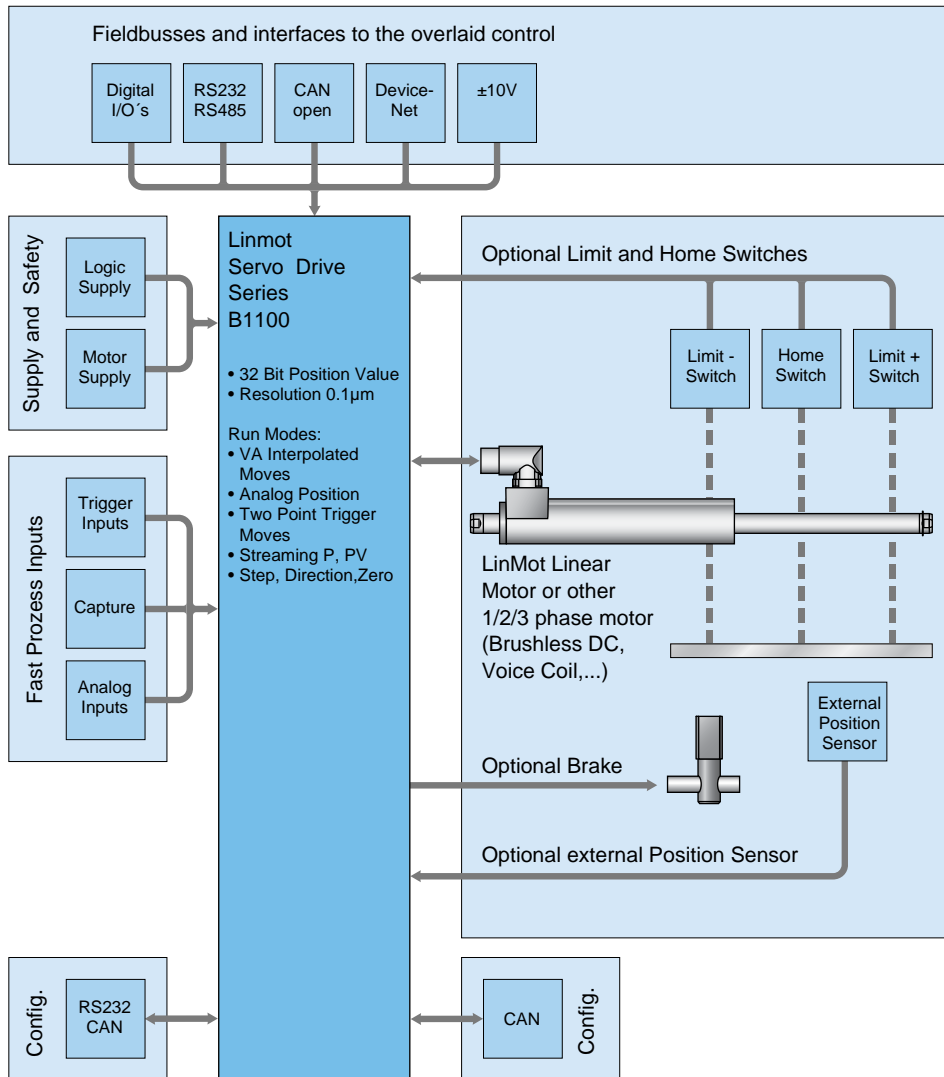

System Integration

Flexible hardware enables control of any 1/2/3-phase motors. Thus, low-power rotary servomotors, such as brushless DC motors, can be integrated in the same controls concept.

Additionally, the drives can be equipped with optional peripherals, such as reference and end stop switches, high-precision external position sensors, or a mechanical holding brake.

Series B1100 Servo Drives have analog inputs and digital inputs and outputs, serial interfaces, and fieldbus connections. The user is therefore not dependent on the selection of the overarching drive.

With flexibility and a compact form factor, LinMot Series B1100 Servo Drives provide a complete solution for a flexible drive concept in single and multiple axis applications, with linear motors and other actuators.

Position Streaming

With a cyclical target value, or "position streaming," the overarching NC or CNC drive communicates with the Servo Drive through CanOpen or DeviceNet.

The position and velocity calculated in the overarching drive is transmitted to the Servo Drive cyclically. The P, PV, or PVT mode is available for this transmission.

Using the cyclical target value, complex motions and interpolating multi-axis applications can be implemented.

Motor Interfaces

The series B1100 Servo Drives allow control of 1, 2, or 3 phase linear motors and brushless rotary servomotors.

B1100 Servo Drives provide all necessary interfaces to operate linear or rotary motors with optional external peripherals, such as end position and reference switches, a mechanical brake, or a high-resolution external position sensor.

Configuration

Parameterization and configuration of the Servo Drive is done via the RS232 interface on the front side, or CANBus for simultaneous configuration of several drives..

LinMot Talk user-friendly PC software is available for configuration. In addition to on-line documentation, LinMot Talk provides extensive debugging tools, such as an oscilloscope and an error inspector, for simple and rapid start-up of the axes.

Fieldbus and Ethernet drives can also be configured directly by the overarching drive.

Position Indexing

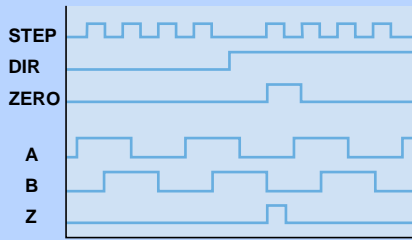

In position indexing, the linear motor is controlled like a stepper motor, using Step/Dir/Zero, or A/B signals. The step distance is freely programmable from $1.5 \times 10^{-6} \mu\text{m}$ to 3.275mm/step. The input signal can be used directly as the target position, or it can be filtered by the VA interpolator.

Operating Modes:	Step/Dir/Zero, A/B
Inputs:	differential RS422 (X13/14)
Step distance:	$1.5 \times 10^{-6} \mu\text{m}$3.275mm, 32 Bit
Max Input Frequency:	2 MHz

+/- 10V Analog Force / Velocity Control

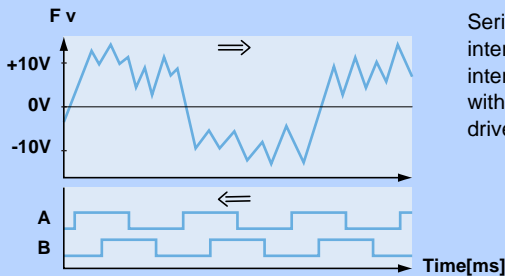

Series B1100 drives allow analog force (torque) or velocity targets to be set, via the +/- 10V interface, by an overlaid position drive. The current actual position is output via the encoder interface, with adjustable resolution, as positioning feedback. In high-precision applications with high-resolution external position sensors, the sensor signals can be passed through in the drive.

Analog Input:	-10...+10V, differential
Resolution:	Max. 12 Bit
Scanning rate:	Max. 10 kHz
Encoder Simulation:	1,2,5,10,20µm Resolution

Setpoint Streaming

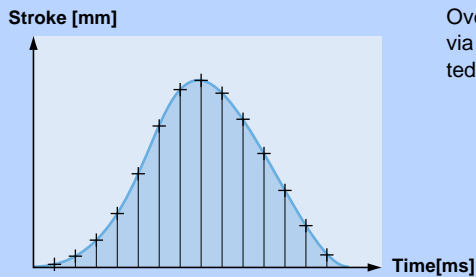

Overlaid NC drives with CANopen or DeviceNet interfaces communicate with the Servo Drives via "Position Streaming". The position and velocity calculated in the overlaid control is transmitted to the Servo Drive cyclically. The P, PV, or PVT mode is available for this transmission.

Position Resolution:	32 Bit
Velocity Resolution:	32 Bit
Interpolator:	5 kHz
cycle times:	2-5ms

Analog Position

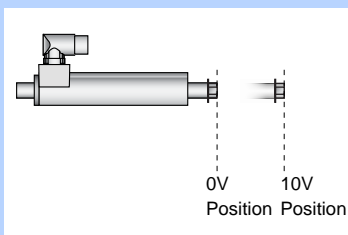

For an analog position target, the linear motor travels to a position proportional to the input voltage. The position is either scanned continuously, or only after a rising edge of the trigger signal. In order to prevent uncontrolled jumps in position, the motor travels to the positions with a programmable maximum acceleration and velocity (VA interpolator).

Inputs:	Analog Inputs (X14.20, X14.8/X14.21)
Voltage range:	0 - 10VDC (X14.20) -10 - +10VDC (X14.18/X14.21)
Resolution:	10 Bit
Scanning rate:	400µsec

Interpolated Moves

Stroke [mm]

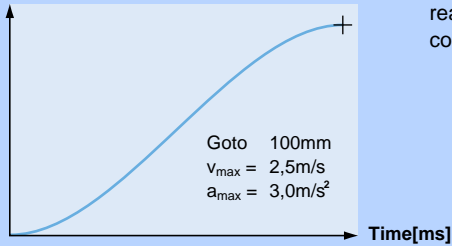

For direct position targets, using absolute or relative positioning, the desired position is reached using an acceleration and velocity-limited motion profile (VA interpolator). Positioning commands can be invoked via the serial interfaces, CANopen, DeviceNet, or a trigger input.

Stroke range:	±100m
Position Resolution:	0.1µm (32Bit)
Velocity Resolution:	1.0µm/s (32Bit)
Velocity Resolution:	10.0µm/s ² (32Bit)

Easy Steps

Input 1	Pos 125mm
Input 2	Pos 250mm
Input 3	Pos 50mm
Input 4	Pos -30mm

With the Easy Steps function, up to 6 positions or independent travel commands can be stored on the drive, and addressed via 6 serial interfaces, CANopen or DeviceNet.

Digital inputs:	max. 6
Interface:	X14
Scanning rate:	400µsec

Easy Steps Parameter Scale

Maximum Force [0...10V => 0...100%]

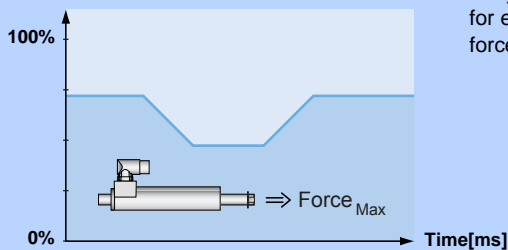

Easy Steps provide the ability to parameterize internal parameters using two analog inputs. If, for example, the maximum motor current is read at an analog input, then the maximum motor force can be provided as analog for freely programmable joining processes.

Inputs:	Analog Inputs (X14.20, X14.8/X14.21)
Voltage range:	0 - 10VDC (X14.20) -10 - +10VDC (X14.18/X14.21)
Resolution:	10 Bit
Scanning rate:	400µsec

B1100-PP
B1100-PP-HC
B1100-PP-HC-XC

- X Position Indexing
- X ±10V Force or Velocity Control
- X Setpoint Streaming (CAN)
- ✓ Analog Position Target
- ✓ MPC Commands
- ✓ Easy Step
- ✓ Easy Steps Parameter Scale
- X Serial Infaces RS232/RS485
- X CANopen
- X DeviceNet
- X Encoder Simulation

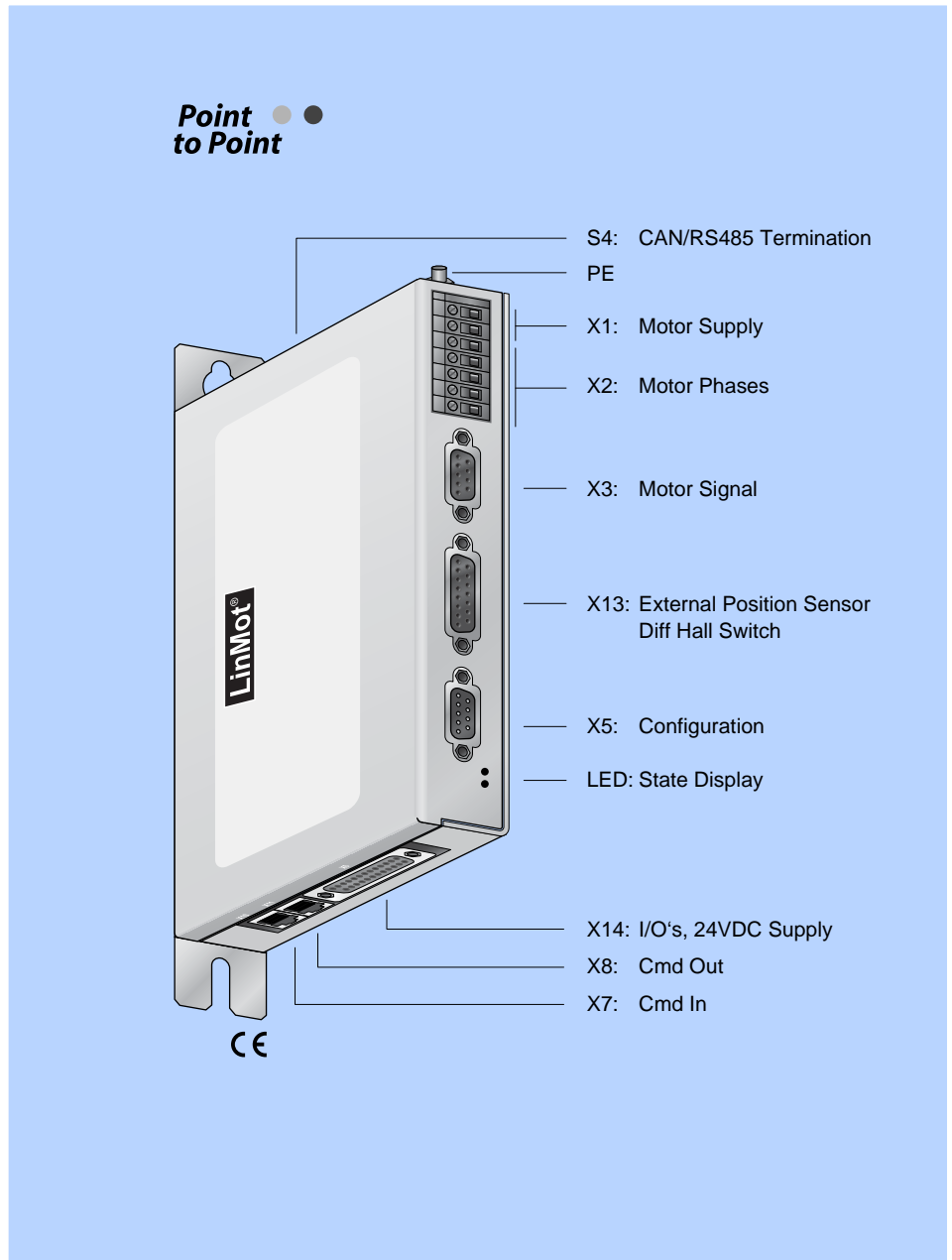

Replacing Pneumatics

Due to their simple controls via digital inputs and outputs, B1100-PP drive make excellent substitutes for pneumatic cylinders.

Using digital inputs, the linear motor can move to up to six freely programmable positions. As soon as the linear motor has reached the position, the corresponding In-Position output is actuated.

The linear motor can thus be controlled like a pneumatic cylinder with end position switches.

Easy Steps positioning commands

Using the Easy Steps function, up to six absolute or relative move commands can be stored in the drive, and invoked via six digital inputs.

Easy Steps also provide the ability to parameterize internal parameters using two analog inputs. If, for example, the maximum motor current is read at an analog input, then the maximum motor force can be provided as analog for freely programmable joining processes.

Analog Position Target

Any position can be set, using an analog 0...10V signal.

During configuration, for each position value, one input signal of 0V and 10V is programmed. Any intermediate position can then be set via the analog input signal during operation.

The dynamics can be constrained by limits on speed and acceleration.

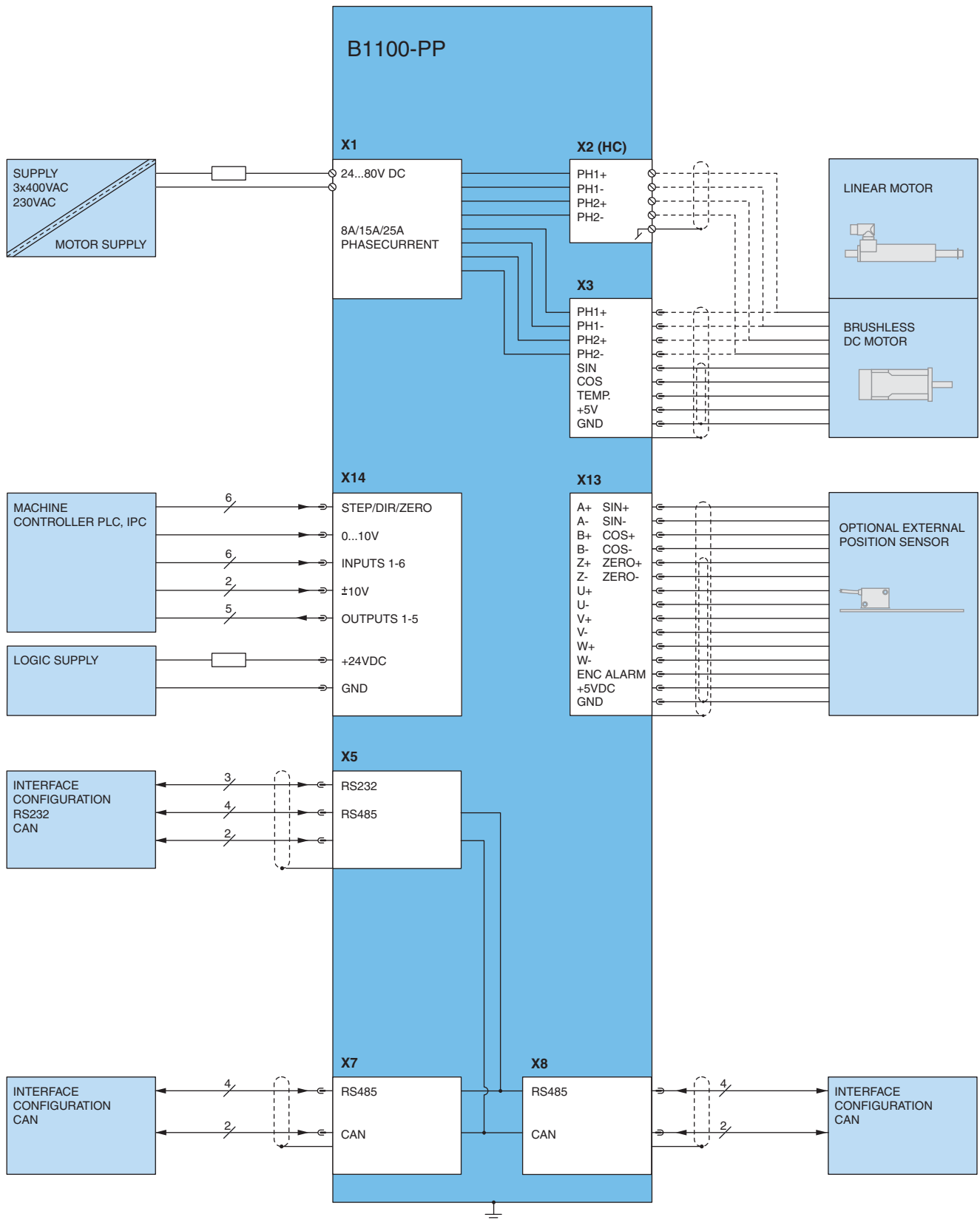

Item	Description	Part Number
B1100-PP	Point to Point Drive (72V/8A)	0150-1735
B1100-PP-HC	Point to Point Drive (72V/15A)	0150-1736
B1100-PP-XC	Point to Point Drive (72V/25A)	0150-1740

B1100-VF
B1100-VF-HC
B1100-VF-XC

- ✓ Position Indexing
- ✓ ±10V Force or Velocity Control
- ✗ Setpoint Streaming (CAN)
- ✓ Analog Position Target
- ✓ MPC Commands
- ✓ Easy Step
- ✓ Easy Steps Parameter Scale
- ✗ Serial Infaces RS232/RS485
- ✗ CANopen
- ✗ DeviceNet
- ✓ Encoder Simulation

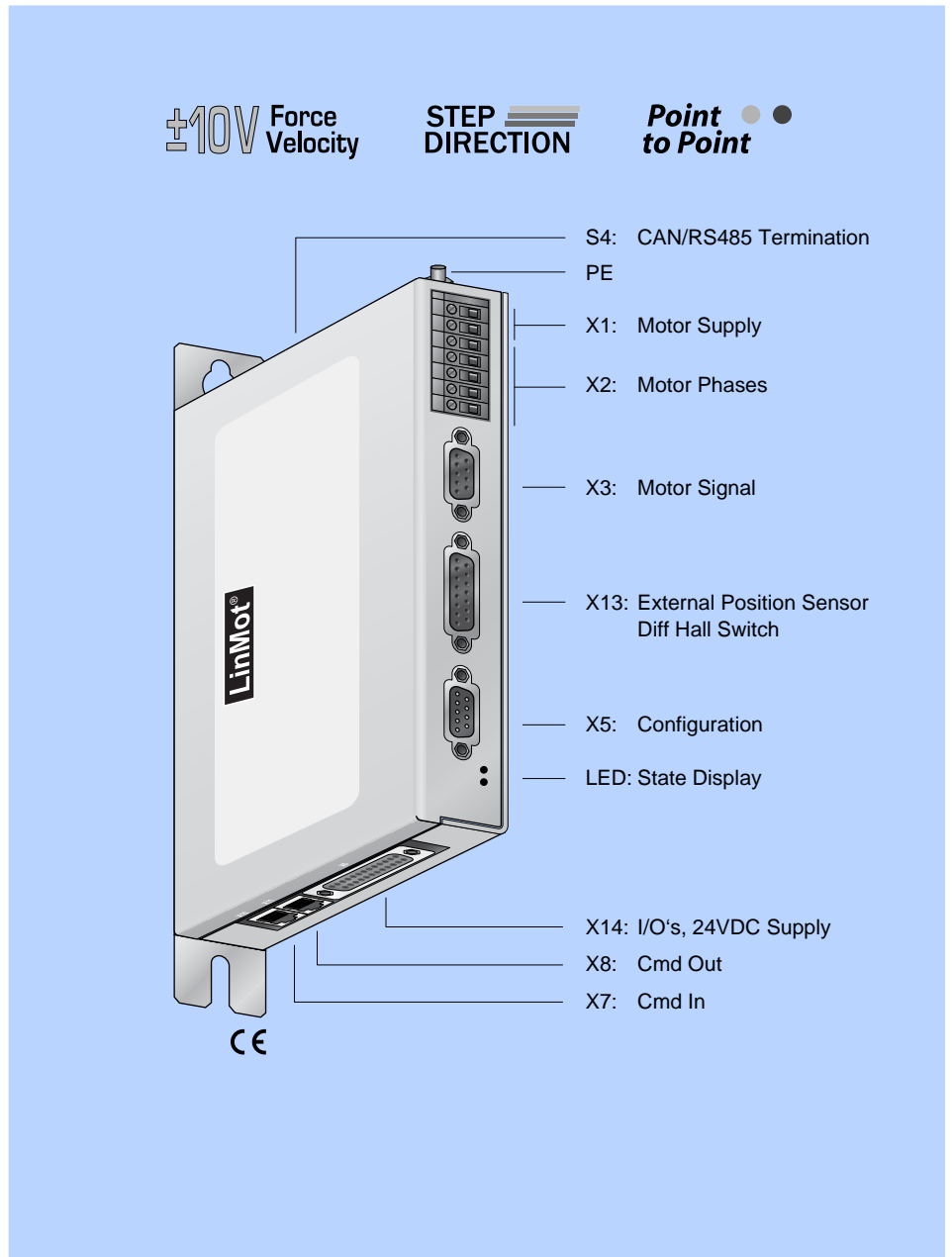

±10V 10V Force or Velocity Control,

The B1100-VF servo amplifier allows LinMot linear motors to be integrated in systems an overlaid axis drive with analog velocity (RPM) or force target (torque).

In velocity mode, the analog input voltage is used as a velocity target for the connected linear motor. The velocity control loop is closed via a PI drive in the amplifier.

In force mode, the amplifier works like a torque amplifier for rotary motors. The analog control signal is converted to a current that the VF amplifier applies to the connected motor.

Step and Direction Interface

Motor force is proportional to the current motor current (see motor data sheets for force constant c_f).

For step-direction targets, the target position is provided by the overlaid drive via STEP, DIRECTION, and ZERO signals.

The maximum motor current (force) can be limited via a digital input.

Encoder Simulation

No additional external sensors are needed for position measurement. The current actual position of the linear motor is captured by the integrated position measurement, and is available to the overlaid position drive as an encoder signal.

The resolution of the differential A/B encoder signals (RS422) is adjustable in the following ranges:

1µm, 2µm, 5µm, 10µm, 20µm, 50µm

If an external position sensor is used, it can be read by the B1100 amplifier.

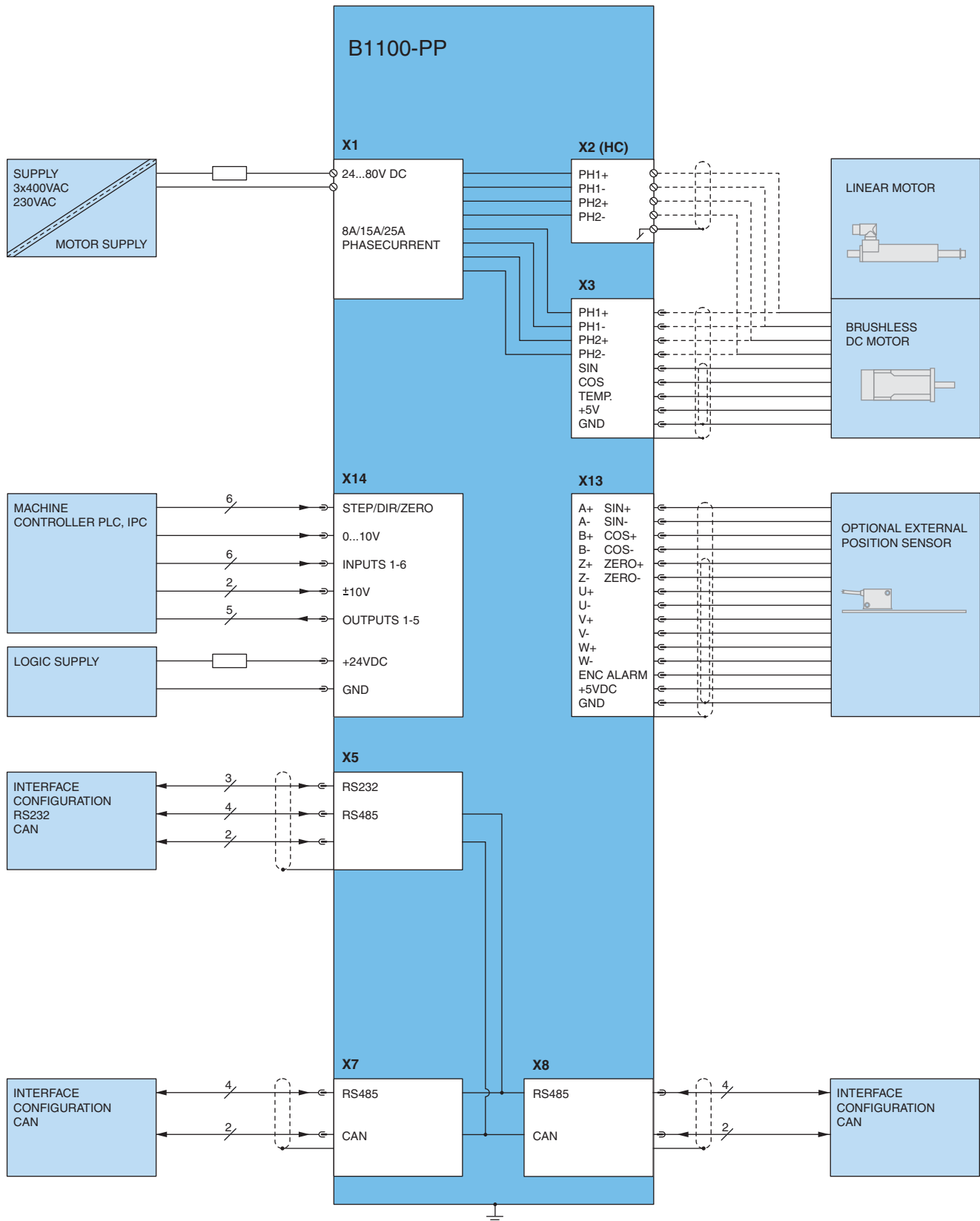

Item	Description	Part Number
B1100-VF	Force Velocity Drive (72V/4A)	0150-1685
B1100-VF-HC	Force Velocity Drive (72V/15A)	0150-1686
B1100-VF-XC	Force Velocity Drive (72V/25A)	0150-1739

B1100-GP
B1100-GP-HC
B1100-GP-XC

- ✓ Position Indexing
- ✓ ±10V Force or Velocity Control
- ✓ Setpoint Streaming (CAN)
- ✓ Analog Position Target
- ✓ MPC Commands
- ✓ Easy Step
- ✓ Easy Steps Parameter Scale
- ✓ Serial Infaces RS232/RS485
- ✓ CANopen
- ✓ DeviceNet
- ✓ Encoder Simulation

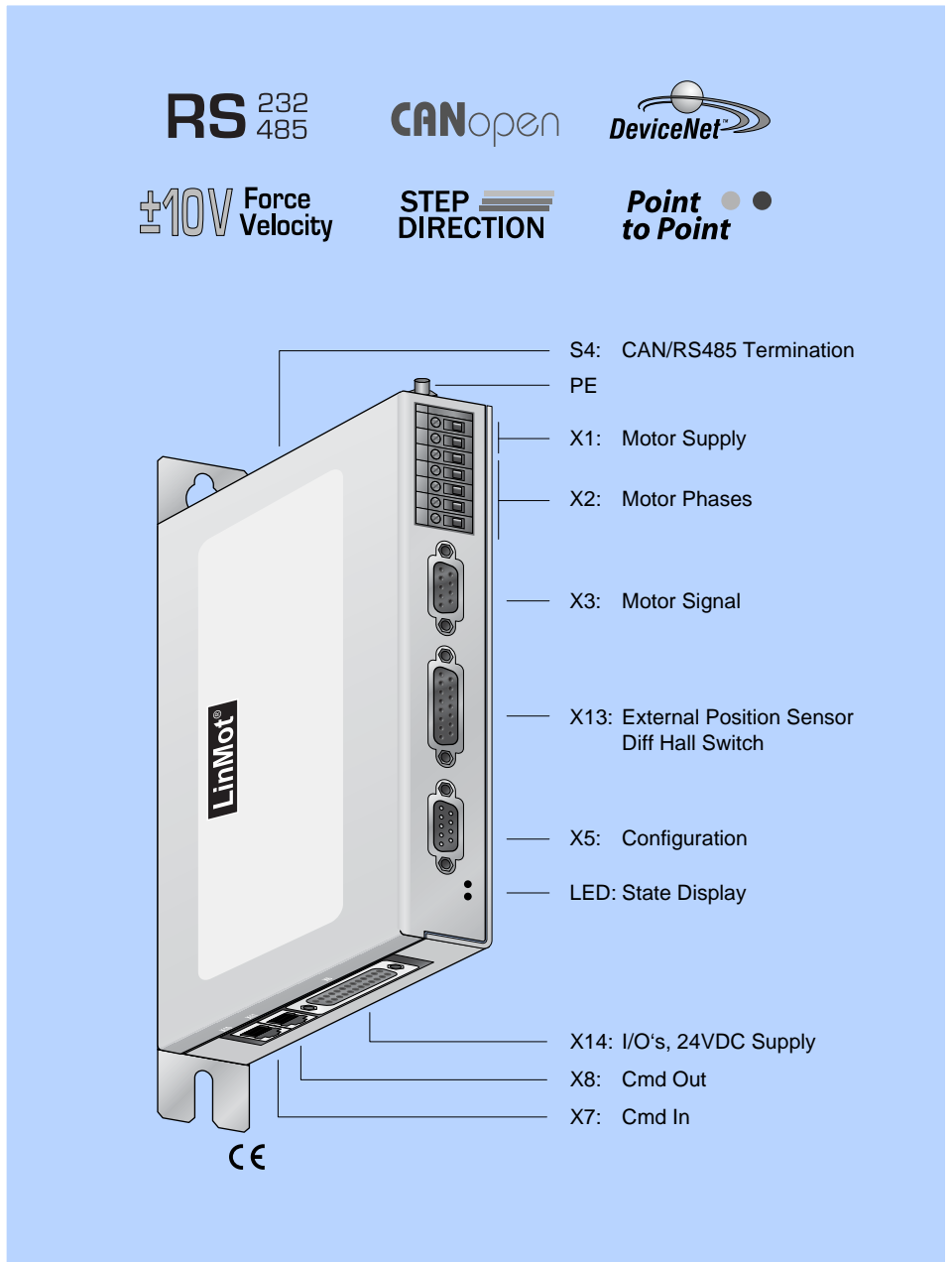

RS232 / RS485

The LinMot B1100-GP series Servo Drives support the LinRS serial communications protocol. LinRS is a proprietary protocol for actuating LinMot Servo Drives via the RS 232, RS 422, and RS 485 interfaces.

If the drive is actuated by the overarching drive via the serial interface, then this is configured from the PC via CanBus. The USBSCAN converter (item no. 0150-3134), supported by LinMot Talk, is used for this.

Adjustable baud rates: 9.6 - 115.2kBaod

CANopen

The LinMot B1100-GP drives support the CiA DS301 communications protocol.

The following resources are available:
 3 T_PDO, 3 R_PDO, 1 T_SDO, 1 R_SDO

The following protocols are supported by the CO drives:

- NMT Error Control (Nodeguarding Protocol or HeartBeat Protocol)
- PDO (Transmission type 254 and 1)
- SDO Upload and Download
- NMT (Start, Stop, Enter PreOp, Reset Node, Reset Communication) Boot-Up Message

DeviceNet

With the DeviceNet protocol, even complicated motion sequences can be realized with the highest possible flexibility.

The drive can be actuated and monitored via the DeviceNet connection.

B1100-GP are UCMM Group 3-capable slaves, and support polled IO runtime data transfer.

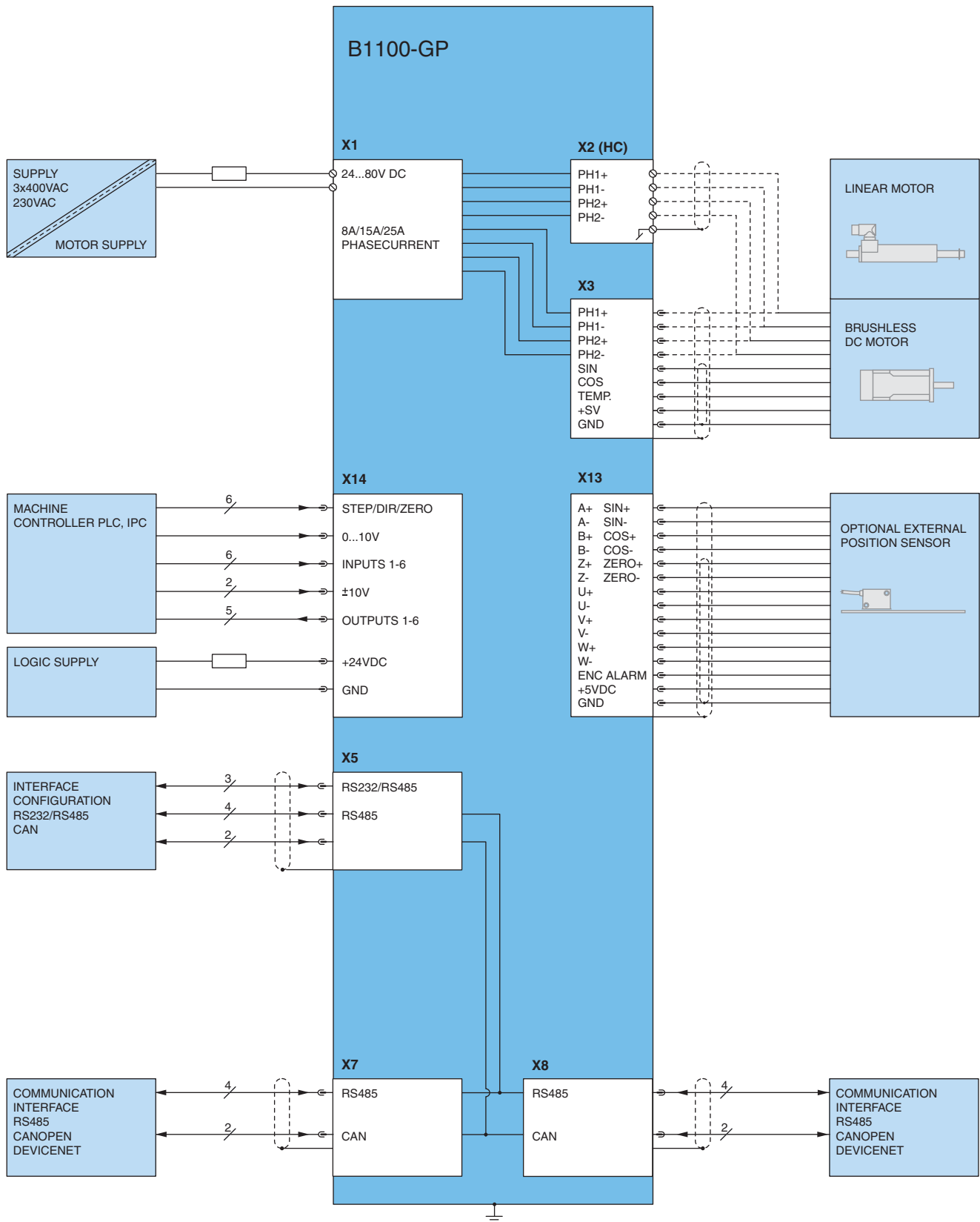

Item	Description	Part Number
B1100-GP	Point to Point Drive (72V/8A)	0150-1737
B1100-GP-HC	Point to Point Drive (72V/15A)	0150-1738
B1100-GP-XC	Point to Point Drive (72V/25A)	0150-1741

X1

Motor Supply



Screw Terminals
2.5 mm² (AWG14)

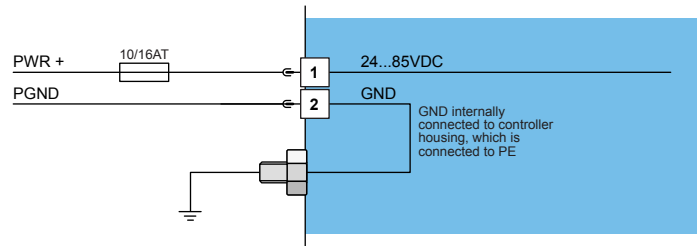

Motor Supply:

Motor Supply Voltage 24...85VDC.
Absolute max. Rating 72VDC + 20%

External fusing: 10AT for LC (8Apeak Servos), 16AT for HC and XC (15/25Apeak) Servos



If motor supply voltage is exceeding 90VDC, the drive will go into error state

X2

Motor Phases

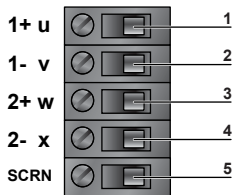

Screw Terminals
1.5-2.5mm²
(AWG16-14)

Nr.	Designation	LinMot Linear Motor	Color	3-Phase-Motor
1	PH1+ /U	Motor Phase 1+	red	Motor Phase U
2	PH1- /V	Motor Phase 1-	pink	Motor Phase V
3	PH2+ /W	Motor Phase 2+	blue	Motor Phase W
4	PH2- /	Motor Phase 2-	grey	
5	SCRN	Shield		

The motor phases on X2 and X3 are internally connected.

If the RMS current is higher than 5A RMS, the phases must be connected to X2 and not to X3.

X3

Motor

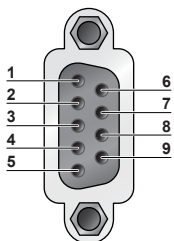

DSUB-9

Nr	LinMot Linear Motor	3-Phase-Motor
1	Motor Phase 1+	Motor Phase U
2	Motor Phase 2+	Motor Phase W
3	+5VDC	
4	Sine	Hall U
5	Temperature	Hall W
6	Motor Phase 1-	Motor Phase V
7	Motor Phase 2-	
8	AGND	
9	Cosine	Hall V
Case	Shield	

- Use X3 for motor phase wiring if phase current does not exceed 2Arms or 4Apeak

- X3.3 (+5VDC) may be used only to supply motor hall-effect sensors (max. 100mA).

- X3.8 (AGND) may be used only to supply motor hall-effect sensors, and must not be connected to GND externally

Motor | Motor wiring

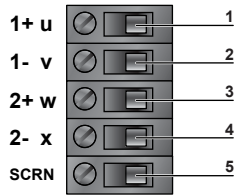

X2: Screw Terminals

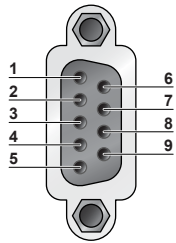

X3: DSUB-9 (f)

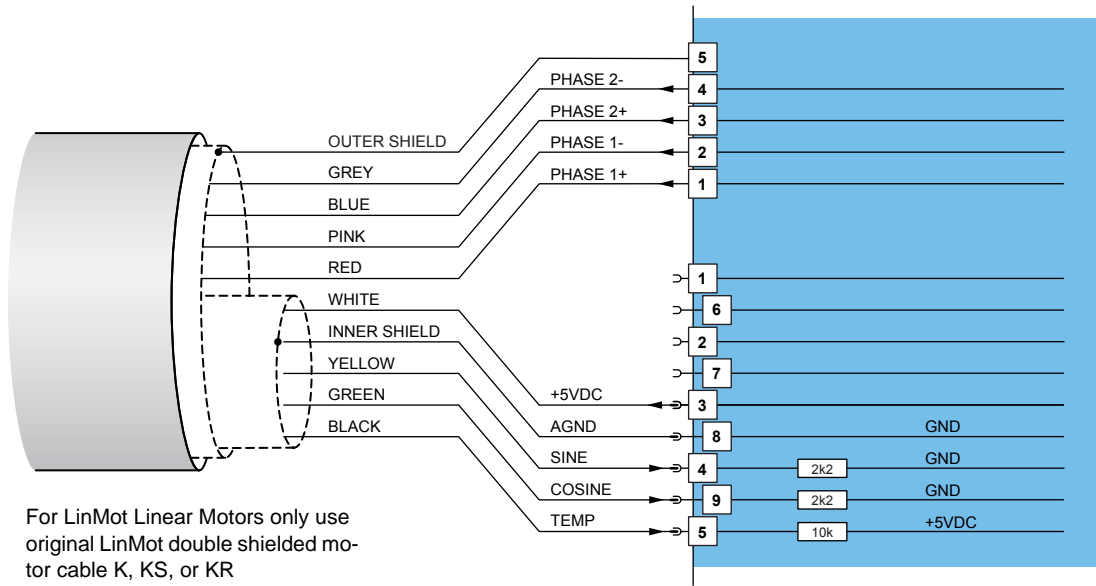

For LinMot Linear Motors only use original LinMot double shielded motor cable K, KS, or KR

Motor | Motor wiring for phase current below 2Arms and below 4Apeak

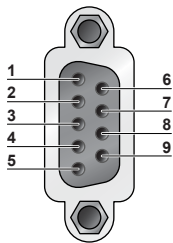

X3: DSUB-9 (f)

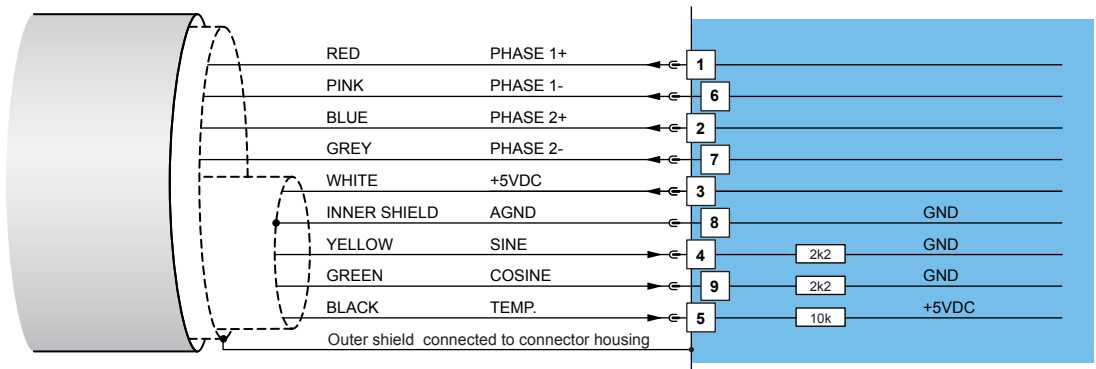

For LinMot Linear Motors only use original LinMot double shielded motor cable K, KS, or KR

S4 | Bus Termination



Switch		
S4	Switch 1: RS232 (switch "off" / RS485 "on")	Select serial RS23 or RS485
	Switch 2: Termination RS485 on/off	
	Switch 3: Termination CAN on/off	
	Switch 4: Bootstrap	Factory settings: all switches "off"

X5 COM

COM Schnittstelle

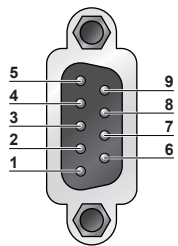

X5: DSUB-9 (m)

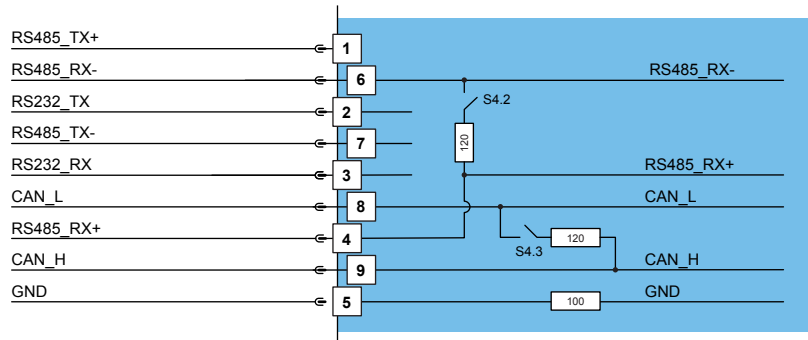

RS232: Configuration on all Drives: use 1:1 connection cable to PC

LED

State Display

Green:

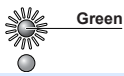

24VDC Logic Supply OK

Red:

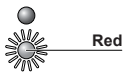

State: Error
Blinking: Fatal Error

X7-X8

RS485/CAN

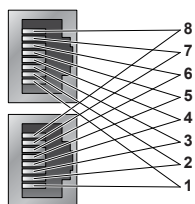

RJ-45

Nr		
1	RS485_Rx+	A
2	RS485_Rx-	B
3	RS485_Tx+	Y
4	GND	
5	GND	
6	RS485_Tx-	Z
7	CAN_H	
8	CAN_L	
Case	Shield	

- X7 internally connected to X8 (1:1 connection)
- Use twisted pair (1-2, 3-6, 4-5, 7-8) cable for wiring.
- The built in CAN and RS485 terminations can be activated by S3.2 and S3.3.

X13

External Position Sensor Commutation

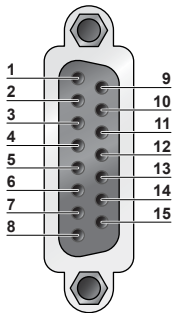

DSUB-15 (f)

Nr	Description	
1	+5V DC	
9	A+	Encoder
2	A-	Encoder
10	B+	Encoder
3	B-	Encoder
11	Z+	Encoder
4	Z-	Encoder
12	Encoder Alarm	
5	GND	
13	U+	Commutation
6	U-	Commutation
14	V+	Commutation
7	V-	Commutation
15	W+	Commutation
8	W-	Commutation
case	Shield	

Max. Input Frequency: 2MHz (incremental RS422), 240ns edge separation

Sensor Supply Current: max. 100mA

Position Encoder Inputs: RS422, Max Input Frequency: 2MHz, 4 M counts/s with quadrature decoding, 240ns edge separation

Encoder Simulated Outputs:RS422, Max Output Frequency: 2.5MHz, 5 M counts/s with quadrature decoding, 200ns edge separation

Differential Hall Switch Inputs: RS422, Max Input Frequency: <1kHz

Enc. Alarm In: 5V / 1mA

Sensor Supply: 5VDC, max 100mA

X14

Digital I/O

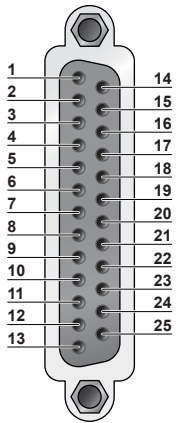

X14: DSUB-25 (f)

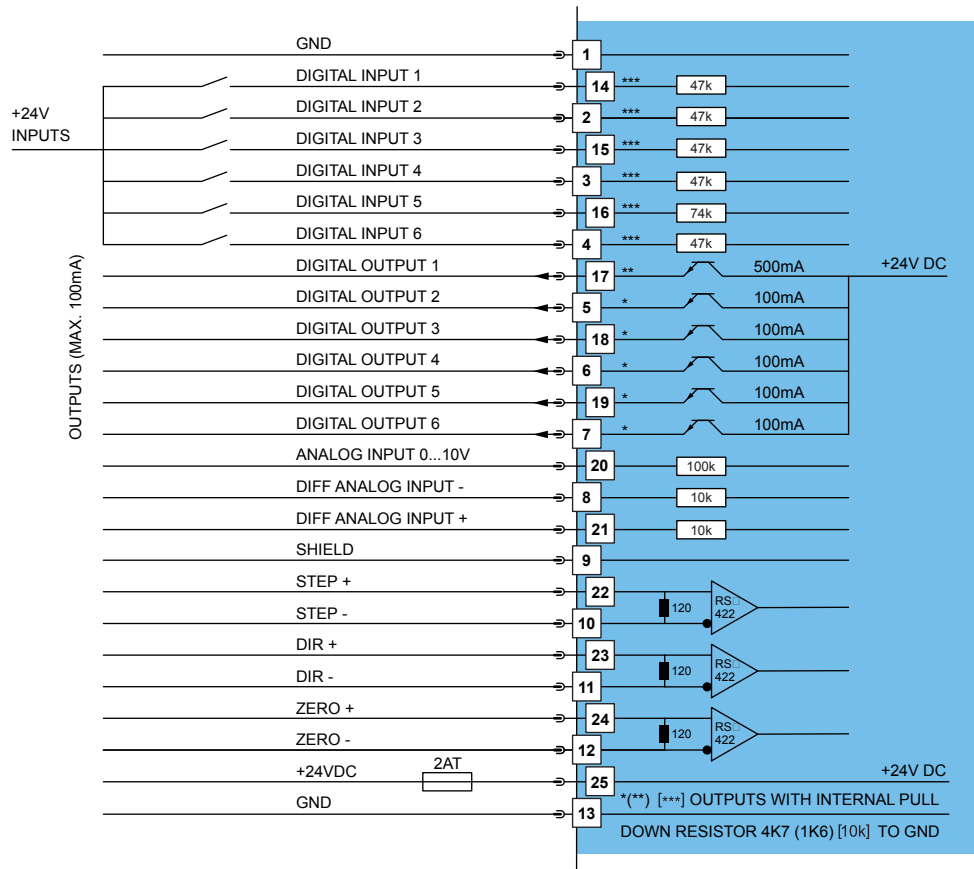

Logic Supply:	Switch Mode Power Supply:24VDC (22...26VDC)
	External Fuse: 2AT
All Digital Inputs:	Direct interfacing to digital 24VDC PLC outputs.
	Input Current: 1mA
	Logic Levels: Low Level: guaranteed: -5 to 5VDC, typically < 8VDC
	High Level: guaranteed: 20...30VDC, typically > 16VDC
	Sample Rate: 400us
All Digital Outputs:	Short circuit and overload protected high side switches
	Voltage: 24VDC
	Sample Rate: 400us
	Max. Current: 100mA / 500mA (X14.17)
	Peak Current: 370mA / 1100mA (X14.17)
	Outputs may directly drive inductive loads.
Analog Input on X14.20:	Range: 0V..+10V 10Bit ADC
	Sample Rate: 400us
Differential Analog Input on X14.8 X14.21 X14.9	Range: -10V..+10V 10Bit ADC
Shield:	Sample Rate: 400us
Differential Step Dir Zero:	Indexer Inputs: RS422
	Max. Input Frequency: 2MHz
	4 M counts/s with quadrature decoding, 240ns edge separation
Cable length:	<30m

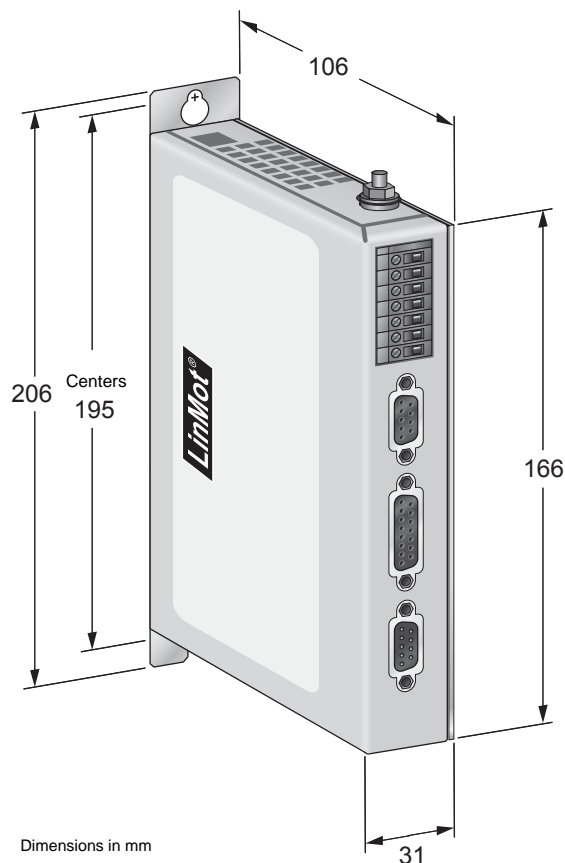

Servo Drive Series B1100

Width	mm (in)	31 (1.3)
Height	mm (in)	166 (6.6)
Height without fixings	mm (in)	206 (8.1)
Depth	mm (in)	106 (4.2)
Weight	g (lb)	700 (1.6)
IP Protection class	IP	20
Storage temperature	°C	-25...40
Transport temperature	°C	-25...70
Operating temperature	°C	0...40 at rated date 40...50 with power derating
Max. case temperature	°C	70
Max. power dissipation	W	30
Min. distance between drives	mm (in)	20 (0.8) left/right 50 (2) top/bottom

Item	Description	Part Number
B1100-PP	Point to Point Drive (72V/8A)	0150-1735
B1100-PP-HC	Point to Point Drive (72V/15A)	0150-1736
B1100-PP-XC	Point to Point Drive (72V/25A)	0150-1740
B1100-VF	Force Velocity Drive (72V/8A)	0150-1685
B1100-VF-HC	Force Velocity Drive (72V/15A)	0150-1686
B1100-VF-XC	Force Velocity Drive (72V/25A)	0150-1739
B1100-GP	Point to Point Drive (72V/8A)	0150-1737
B1100-GP-HC	Point to Point Drive (72V/15A)	0150-1738
B1100-GP-XC	Point to Point Drive (72V/25A)	0150-1741

Switched-Mode Power Supplies

115VAC / 230VAC

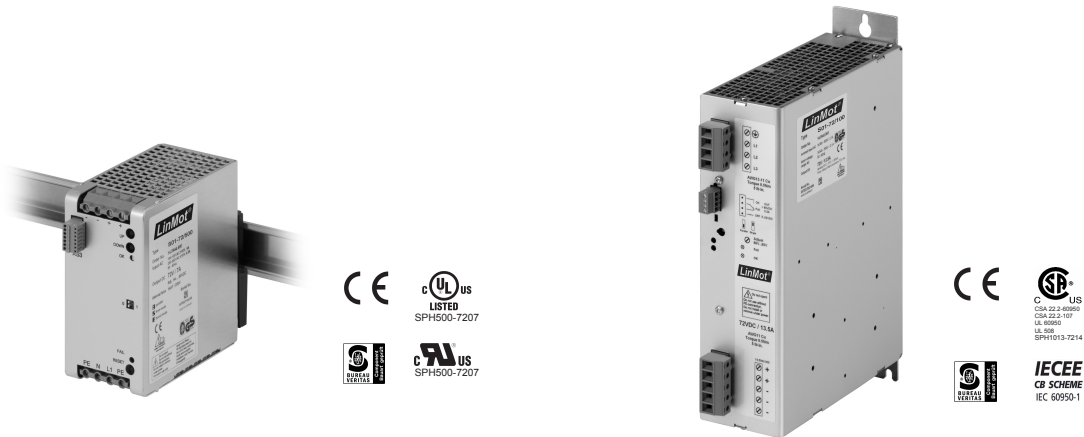

Item	Description	Part Number
S01-72/500	Switched-Mode Power Supply 72V/500W	0150-1874
S01-72/1000	Switched-Mode Power Supply 72V/1000W	0150-1872

Transformer Supply T01

3x230/280/400/480VAC



Item	Description	Part Number
T01-72/420...1500-Multi	Transformer Supply 3x230/280/400/480VAC, 50/60Hz, 420...1500W	see page 534

Control Box B01-E1100



Item	Description	Part Number
B01-E1100	Control Box for E1100 (incl. cable and connectors)	0150-1970
B01-B1100	Control Box for B1100 (incl. cable and connectors)	0150-2110

Connector Cable and USB-Converter



Item	Description	Part Number
RS232 PC config. cabel 2m	for E100/E1001/E1100/B1100	0150-3307
USB-Serial Converter	USB to 9-pin Serial Converter	0150-3110
USB-CAN Converter	USB to CAN Converter for E1100/B1100	0150-3134
RJ45-08/0.3	RJ45 patch cable 0.3m for E1100/B1100	0150-1852
RJ45-08/0.6	RJ45 crossover patch cable 0.6m	0150-1853

Option: External High Resolution Encoder



Item	Description	Part Number
MS01-1/D	Linear Encoder 1um, A/B (for 1mm magnetic band)	0150-1840
MB01-1000	Magnetic Band 1mm pitch, per cm	0150-1963