

Installation Guide Electric Gripper

ENG

GM50 2-Finger Parallel Gripper



Content

1	General Information	4
1.1	Introduction	4
1.2	Explanation of Symbols	4
1.3	Qualified Personnel	4
1.4	Liability	4
1.5	Copyright	4
2	Safety Instructions	5
3	Intended Use	7
3.1	Designation code	7
3.2	Variations and identification	7
3.2.1	Identification by type plate	7
3.3	Product description Gripper GM50	8
3.4	Operating conditions	8
4	Installation Instructions	9
4.1	Mounting direction and MagSpring	11
4.1.1	Mounting direction	11
4.1.2	Mounting direction with option MagSpring	13
4.1.3	MagSpring force effect	13
4.2	Side mounting of the gripper	14
4.2.1	Fastening the mounting adapter	14
4.2.2	Mounting of the gripper on the left side of the module	15
4.2.3	Mounting of the gripper on the right side of the gripper	16
4.3	Frontal mounting of the gripper	17
4.3.1	Fastening the mounting adapter	17
4.3.2	Mounting of the gripper	18
5	Electrical Connection	19
5.1	Motor cable	19
5.1.1	Technical data	19
5.2	Mounting the motor cable	20
5.2.1	GM50-23	20
5.2.2	GM50-37	20
5.3	Stator connector assignment	21
6	Calculation of the Load Moments	22
7	Start-up	23
7.1	General information	23
7.2	Setting the parameters	24
7.3	Plug-and-Play	24
7.3.1	Application-specific parameters	24
7.3.2	Referencing the gripper	24
7.3.3	Current/force limitation of the gripper	24
7.3.4	Gripper rest position with MagSpring load compensation option	25
8	Parameters	26

8.1	Motor position/gripper finger position ratio	26
9	Accessories	27
9.1	Motor cable GM50-23	27
9.2	Motor cable GM50-37	28
9.3	Trailing chain kit GM50-23.....	29
9.3.1	Dimensions	29
9.3.2	Overview trailing chain kit	30
9.4	Trailing chain kit GM50-37	31
9.4.1	Dimensions	31
9.4.2	Overview trailing chain kit	32
9.5	Mounting adapter GM50-23.....	33
9.5.1	Adapter for side mounting.....	33
9.5.2	Adapter for frontal mounting	34
9.6	Mounting adapter GM50-37.....	35
9.6.1	Adapter for side mounting.....	35
9.6.2	Adapter for frontal mounting	36
10	Maintenance	37
10.1	Maintenance cycles of the gripper	37
10.2	Inspection.....	37
10.3	Troubleshooting	38
10.4	Cleaning and lubrication	39
10.4.1	Cleaning and lubrication of the linear motor	39
10.4.2	Cleaning and lubrication of the gripping unit	39
11	Storage and Transport	40
12	Dimensions & Weights	41
12.1	Gripper module GM50-23SX80F-XP-K_35-18(_MS03)	41
12.2	Gripper module GM50-23SX160H-XP-K_35-18(_MS03).....	42
12.3	Gripper module GM50-37SX60-XP-N_48-22(_MS03)	43
12.4	Gripper module GM50-37SX120-XP-N_48-22(_MS03)	44
13	International Certificates.....	45
14	EU Declaration of Conformity CE-Marking	48
15	UK Declaration of Conformity UKCA-Marking.....	49

1 General Information

1.1 Introduction

This manual includes instructions for the assembly, installation, maintenance, transport, and storage of linear guides / linear modules grippers. The document is intended for electricians, mechanics, service technicians, and warehouse staff.

Read this manual before using the product and observe the general safety instructions and those in the relevant section at all times.

Keep these operating instructions in an accessible place and make them available to the personnel assigned.

1.2 Explanation of Symbols



Triangular warning signs warn of danger.



Round command symbols tell what to do.

1.3 Qualified Personnel

All work such as installation, commissioning, operation and service of the product may only be carried out by qualified personnel.

The personnel must have the necessary qualifications for the corresponding activity and be familiar with the installation, commissioning, operation and service of the product. The manual and in particular the safety instructions must be carefully read, understood and observed.

1.4 Liability

NTI AG (as manufacturer of LinMot and MagSpring products) excludes all liability for damages and expenses caused by incorrect use of the products. This also applies to false applications, which are caused by NTI AG's own data and notes, for example in the course of sales, support or application activities. It is the responsibility of the user to check the data and information provided by NTI AG for correct applicability in terms of safety. In addition, the entire responsibility for safety-related product functionality lies exclusively with the user. Product warranties are void if products are used with stators, sliders, servo drives or cables not manufactured by NTI AG unless such use was specifically approved by NTI AG.

NTI AG's warranty is limited to repair or replacement as stated in our standard warranty policy as described in our "terms and conditions" previously supplied to the purchaser of our equipment (please request copy of same if not otherwise available). Further reference is made to our general terms and conditions.

1.5 Copyright

This work is protected by copyright.

Under the copyright laws, this publication may not be reproduced or transmitted in any form, electronic or mechanical, including photocopying, recording, microfilm, storing in an information retrieval system, not even for training purposes, or translating, in whole or in part, without the prior written consent of NTI AG.

LinMot® and MagSpring® are registered trademarks of NTI AG.

2 Safety Instructions



Contusions

Sliders contain neodymium magnets and have a strong attractive force. Careless handling could cause fingers or skin to become pinched between two sliders. This may lead to contusions, bruises, and bone fractures. When handling sliders, wear thick protective gloves and keep a minimum distance between sliders. Refer to the "Minimum distance from slider" section for minimum distance.

To reduce the risk of injury, never more than one slider should be held or transported by the same person without packaging.



Pacemaker / Implanted Heart Defibrillator

Sliders could affect the functioning of pacemakers and implanted heart defibrillators. For the duration of a strong approach to a magnetic field, these devices switch into test mode and will not function properly.

- If you wear one of those devices keep the following minimum distances between the pacemaker / defibrillator and slider:
 - Min. 250 mm (10") for slider Ø 27 mm and 28 mm (PL01-27 / 28 / PL10-28)
 - Min. 150 mm (6") for slider Ø 19 mm and 20 mm (PL01-19 / 20)
 - Min. 100 mm (4") for slider Ø 12 mm (PL01-12)
- Inform others who wear these devices to comply with these minimum distances!



Caution - Risk of Electric Shock !

Before working, make sure that there are no high voltages.



Fast-moving Machine Parts

The sliders of LinMot linear motors are fast-moving machine parts. All necessary precautions must be taken to prevent persons approaching the moving elements during operation (provide covers, guards, etc.).



Automatic Restart

The motors can start automatically under certain circumstances! If necessary, a corresponding warning symbol must be provided and protection against entering the hazardous area or a suitable safe electronic disconnection must be provided!



Risk of Injury due to a Defect or Fault

For areas where a defect or fault can result in substantial property damage or even serious personal injury, additional external precautions must be taken or devices must be installed to ensure safe operation even if a defect or fault occurs (eg. suitable safe electronic disconnection, mechanical interlocks, barriers, etc.).



Magnetic Field

Magnets integrated in the sliders produce a strong magnetic field. They could damage TVs, laptops, computer hard drives, credit and ATM cards, data storage media, mechanical watches, hearing aids, and speakers.

- Keep magnets away from devices and objects that could be damaged by strong magnetic fields.
- For the above mentioned objects, keep a minimum distance as described in the "Pacemaker / implanted defibrillator" section.
- For non-anti-magnetic watches, keep the double minimum distance.

**Combustibility**

When machining magnets, the drilling dust could easily ignite. Machining the sliders and the magnets they contain is not permitted.

**Burn Hazard**

During operation the slider can become hotter than 100 °C, which can cause burns if touched. All necessary precautions (e.g. covers, casing, etc.) must be taken to prevent contact with persons in the vicinity of the slider during operation.

**Grounding**

All metal parts that are exposed to contact during any user operation or servicing and likely to become energized shall be reliably connected to the means for grounding.

**Mechanical Handling**

Neodymium magnets are brittle and heat-sensitive. Machining the sliders and the magnets they contain is not permitted.

- Colliding magnets could crack. Sharp splinters could be catapulted for several meters and cause eye injury.
- By machining the sliders, heat would result which demagnetizes the magnets.

**2S Stators**

Series 2S stators correspond mechanically to the respective standard stators and are to be handled in exactly the same way in terms of assembly. For special features, please refer to the safety manual (Item-No. 0185-1174).

**Slider**

Linear motor sliders consist of a high-precision, thin-walled stainless steel tube in which the neodymium magnets are housed. The LinMot sliders should be handled with care. Avoid contact with other sliders or iron parts as this can damage the magnets and the slider surface. Do not grip the sliders with pliers, as this can also damage the surface. Do not use sliders which are already damaged on the surface (scratches, deformation, etc.). This can cause further damage to the stator.

**Effects on People**

According to the current level of knowledge, magnetic fields of permanent magnets do not have a measurable positive or negative effect on people. It is unlikely that permanent magnets constitute a health risk, but it cannot be ruled out entirely.

- For your own safety, avoid constant contact with magnets.
- Store large magnets at least one meter away from your body.

**Temperature Resistance**

Keep slider away from unshielded flame or heat. Temperature above 120°C will cause demagnetization.

3 Intended Use

3.1 Designation code

GM50-23Sx80F-XP-K-35-18-GT21-MSxx

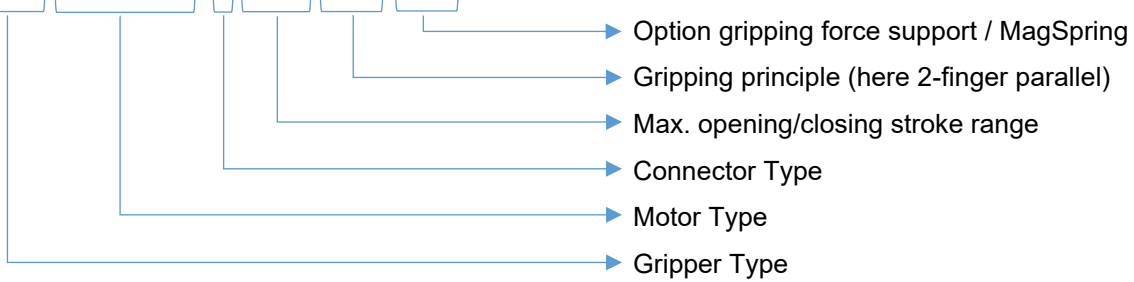

3.2 Variations and identification

3.2.1 Identification by type plate

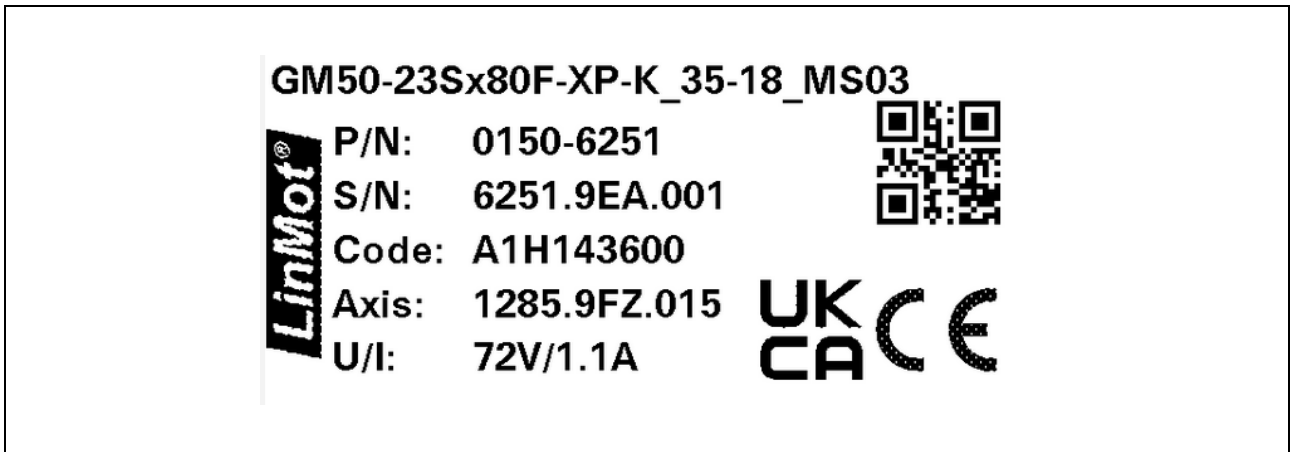

Designation type plate	Meaning
Top line	Gripper type
P/N	Item number gripper
S/N	Serial number gripper
Code	Code for internal use only
Axis	Serial number stator
U/I	Voltage/current

3.3 Product description Gripper GM50

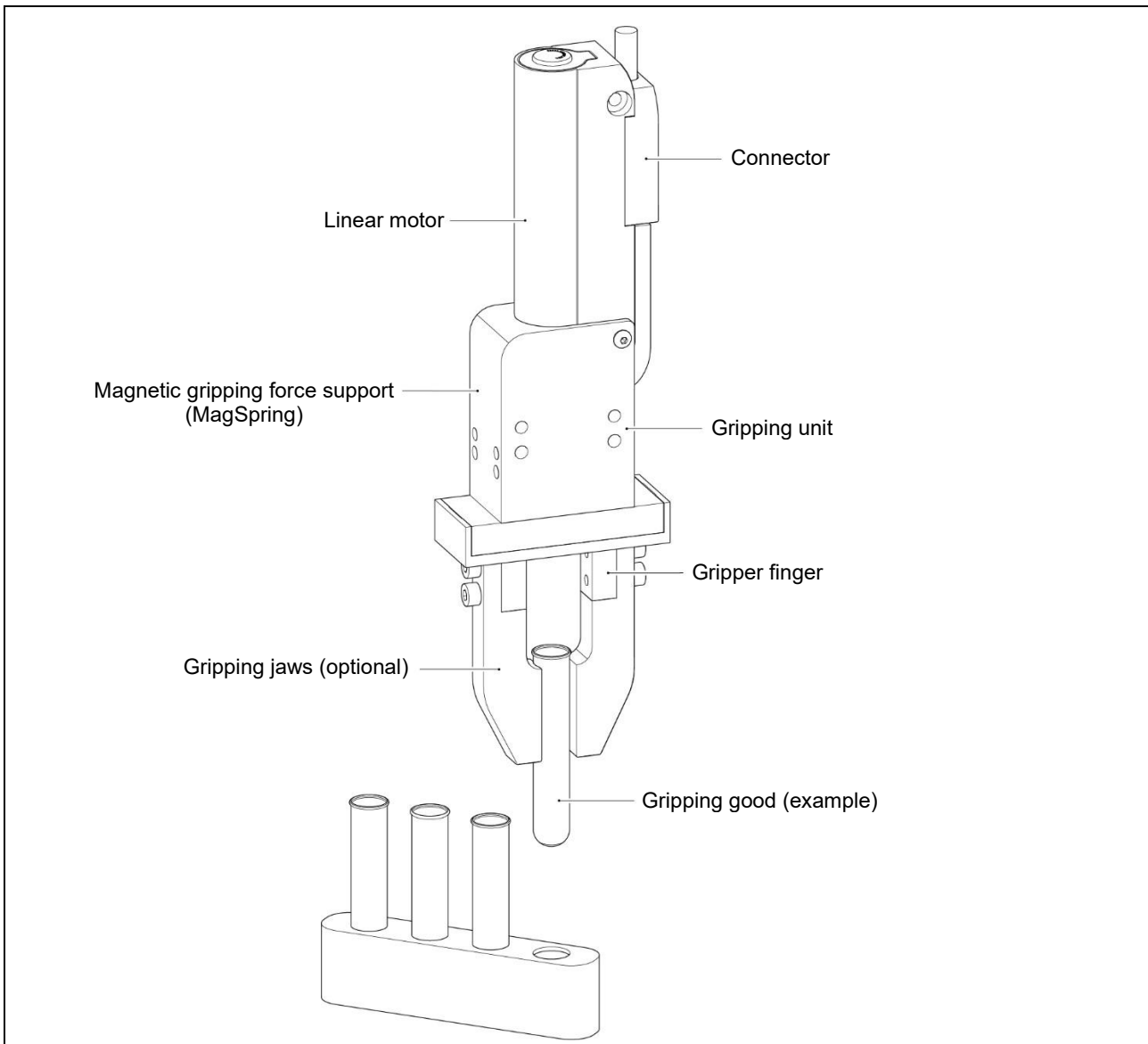

The LinMot GM50 gripper is a highly dynamic solution for demanding applications. With closing and opening times of less than 20 milliseconds, it enables efficient and reliable gripping. Freely programmable motion profiles can be used to make the gripping process particularly gentle, making it easier to handle sensitive objects. The gripper's servo motor enables individual finger positioning and adjustable force control for customised gripping. A special safety feature is the ability to maintain the MagSpring gripping force in the event of a power failure, while the gripper can easily be opened by hand. The clever design ensures tidy cable routing with direct connection to trailing chains, making installation easy. The GM50 also consumes minimal power in both open and closed positions, and is compatible with all common fieldbus systems to ensure seamless integration into existing automation solutions.

3.4 Operating conditions



- Ambient temperature limit is -10°C...80°C
- The maximum sensor temperature is 90°C
- The maximum installation altitude is 4.000 m above sea level. From 1.000 m, a reduction of 1 °C per 100 m must be taken into account for air cooling.

4 Installation Instructions



Before carrying out any of the following operations, all necessary precautions must be taken to ensure that the equipment is not in operation. Before installing the gripper, ensure that the equipment is voltage-free and that the safety measures in Chapter 2 are followed.

The GM50 gripper can be mounted on the front or side of either the LinMot mounting adapter or a customer-specific fixture. The two front M5 holes and the two pin holes run completely through the GM50 gripping unit and can therefore be used for mounting on either side of the gripper. Detailed mounting dimensions can be found in Chapter 11. Corresponding CAD files are available in the LinMot eCatalogue at shop.linmot.com.



- The label on the mounting side must be removed before installation.
- Since the pin holes are continuous, the pins must be additionally secured against slipping out, e.g. with Loctite.

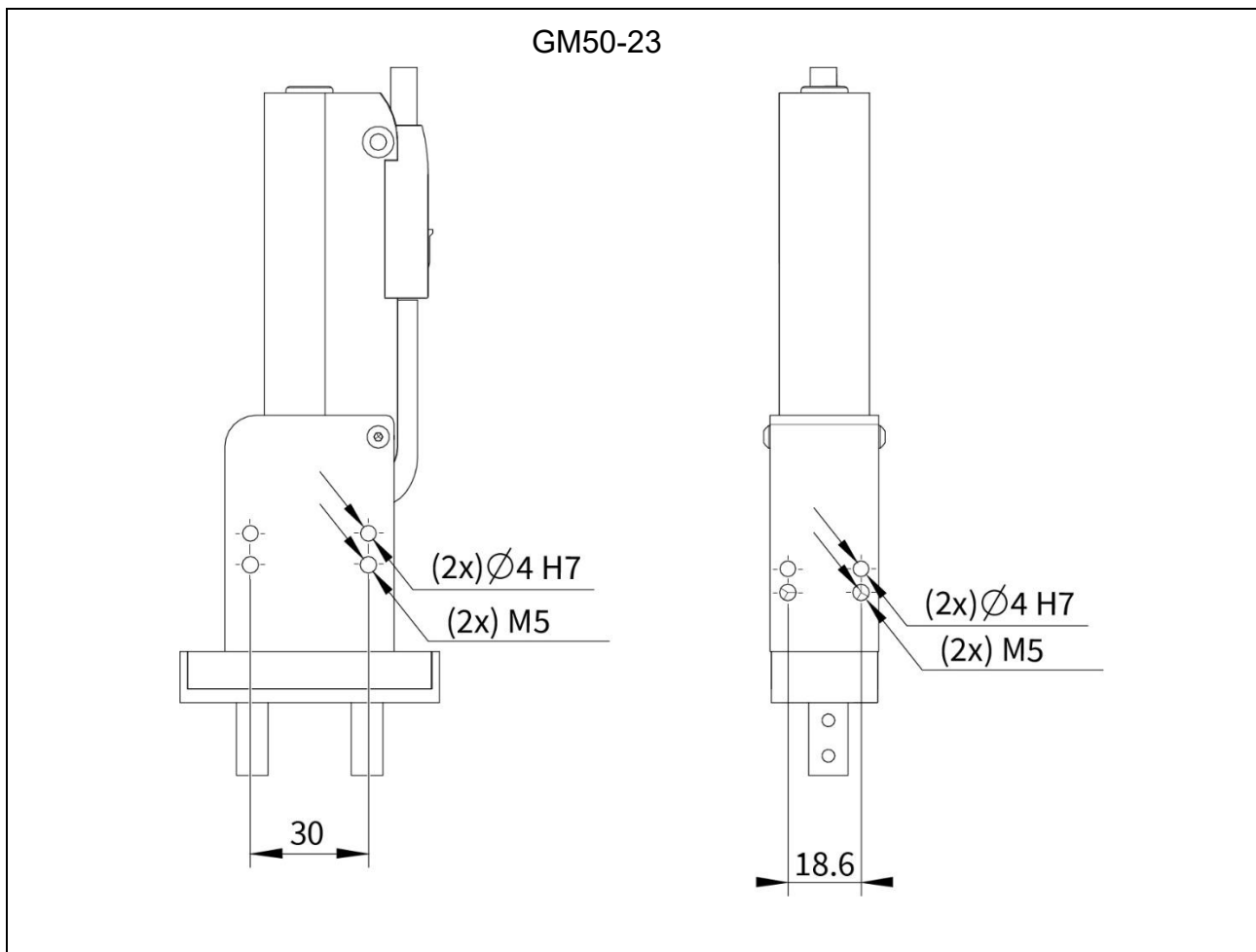

GM50-37

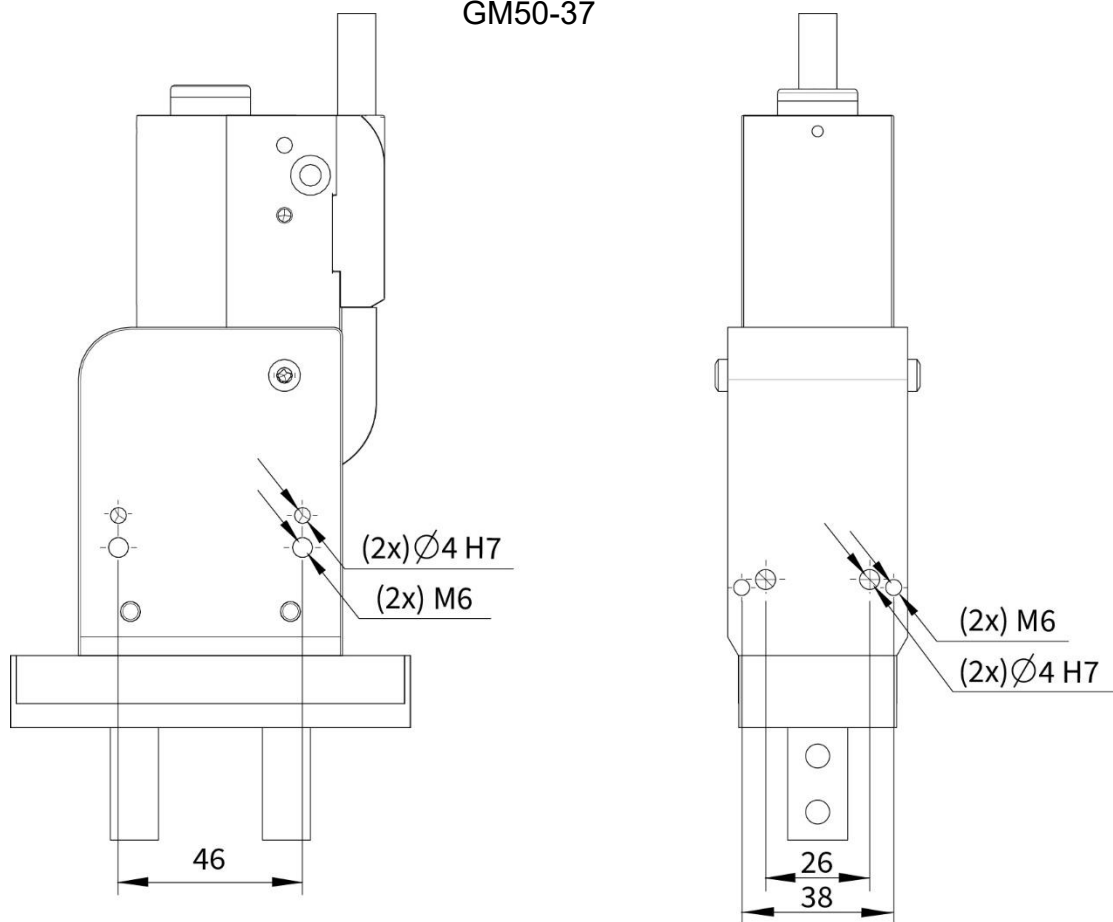

4.1 Mounting direction and MagSpring

4.1.1 Mounting direction



The GM50 gripper can be mounted in various directions. Please note that the mounting position affects the gripping force. The maximum gripping force is achieved when the gripper is mounted vertically, pointing downwards. If the gripper is pointing upwards, gravity acts on the slider and thus against the gripping force, which has a corresponding effect on the gripping force.

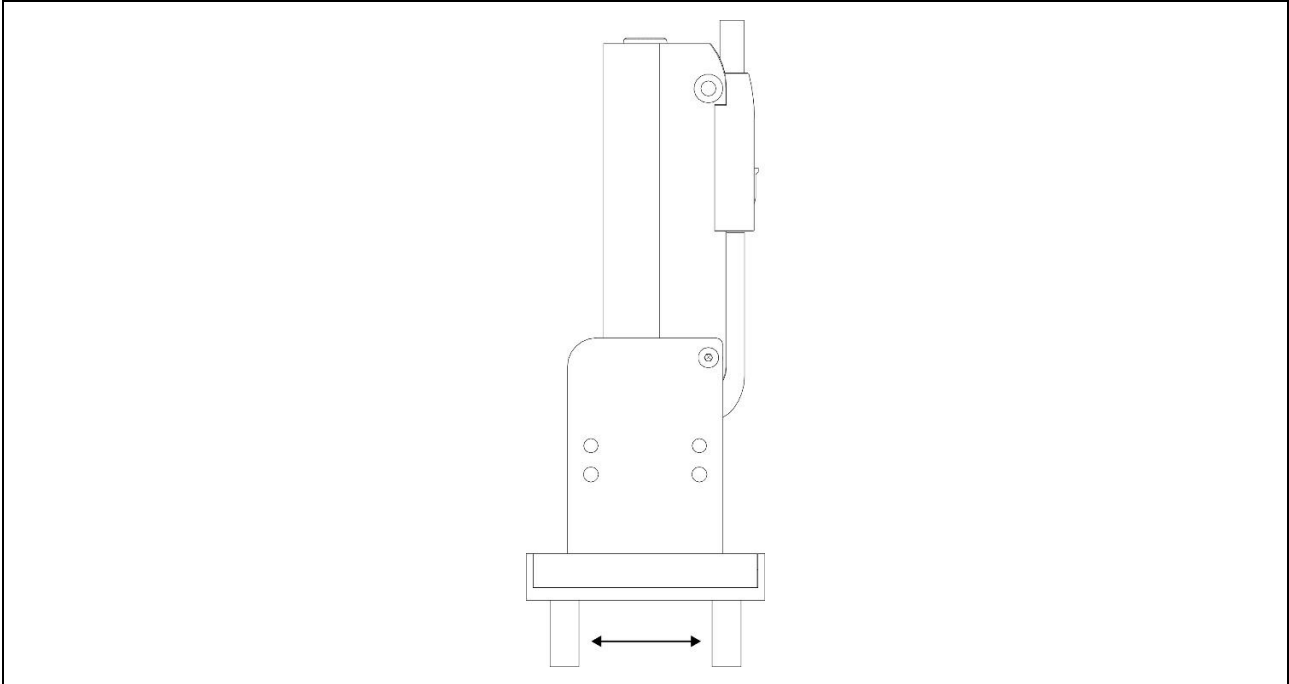

Example 1: "Gripper at bottom" for vertical mounting. This is used for gripping, depositing, mounting, stacking, aligning and centring products.

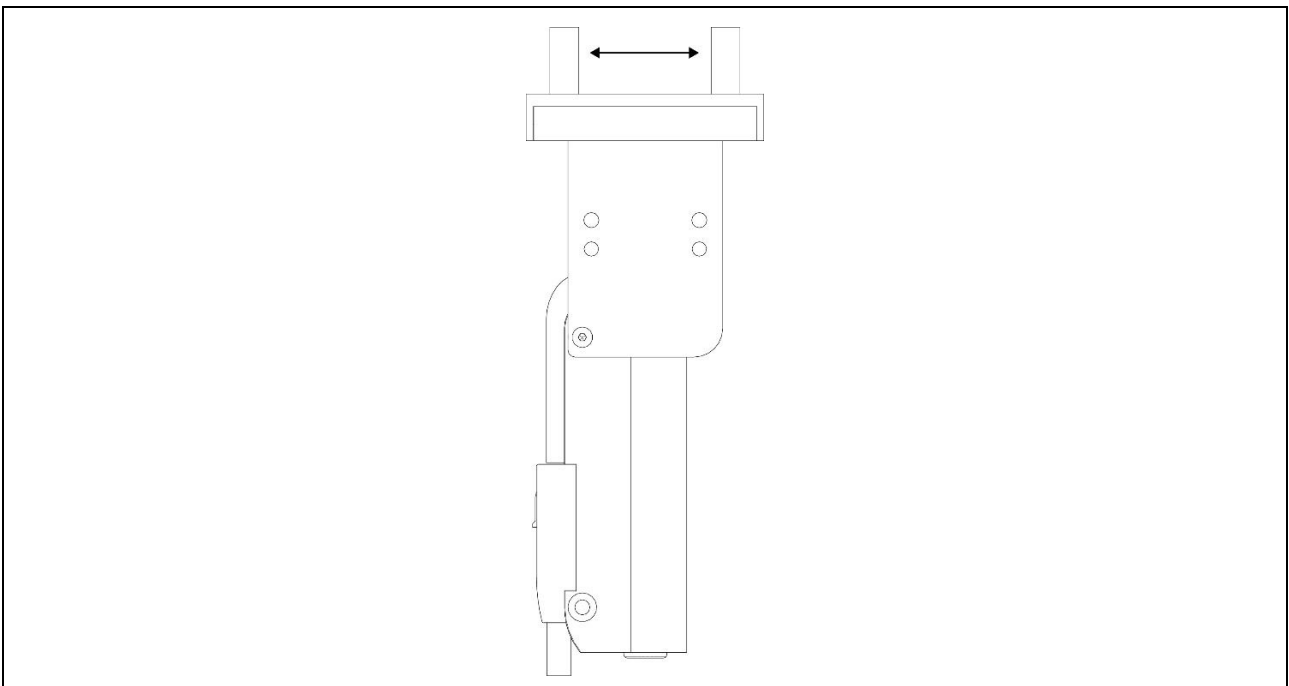

Example 2: vertical mounting with a "gripper at the top". This is used for gripping, placing, mounting, separating, spreading, aligning and centring products.

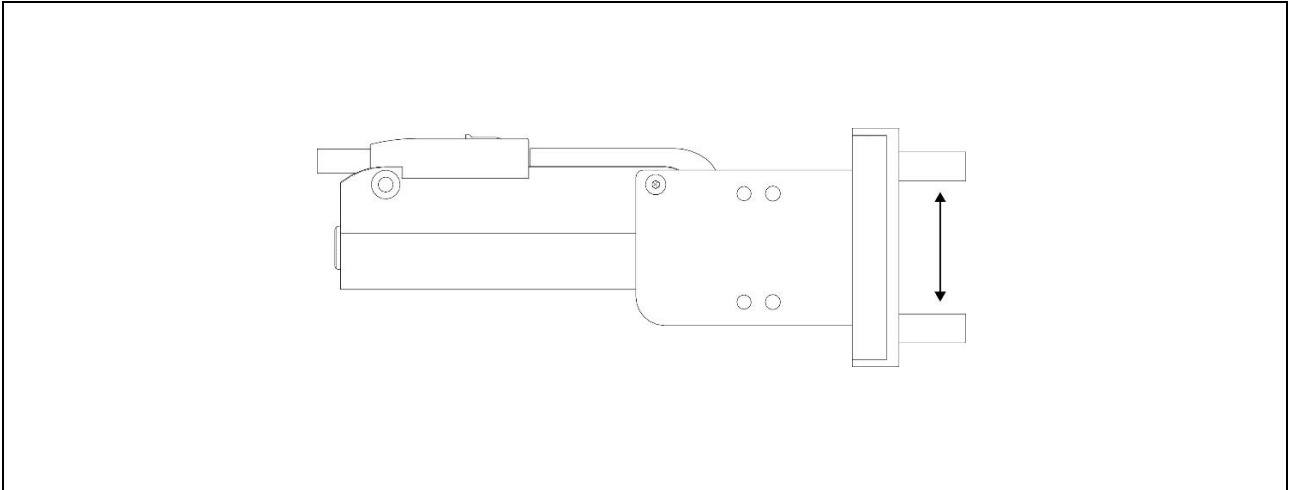

Example 3: horizontal mounting, “gripper sideways”. This is used for gripping, separating, spreading, aligning and centring products.

4.1.2 Mounting direction with option MagSpring

The MagSpring option is a passive clamping force support integrated into the gripper based on a magnetic spring. The MagSpring provides additional clamping force when gripping from the outside and offers a special safety feature that maintains its clamping force in the event of a power failure. Meanwhile, the gripper can easily be opened by hand.



The installation direction affects the effectiveness of the MagSpring. The MagSpring is most effective when the gripper is installed facing downwards. If the gripper is installed facing upwards, the effect of the MagSpring is reduced by gravity.

4.1.3 MagSpring force effect

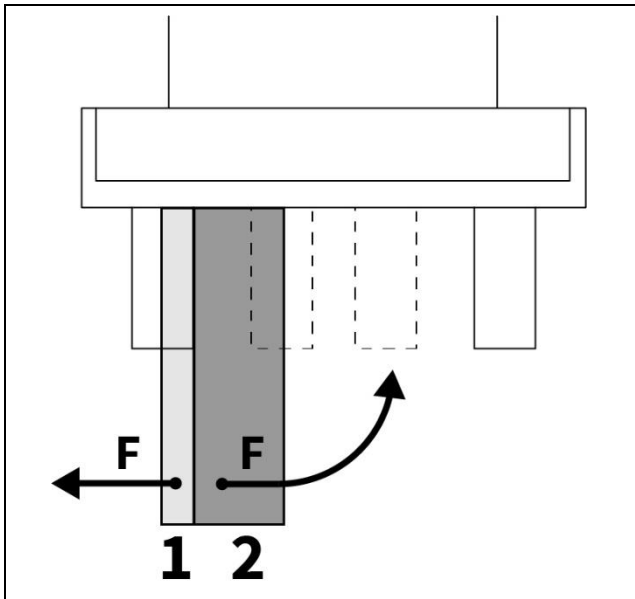

In **area 1**, the MagSpring operates slightly in the direction of opening. This is the area where the gripper is in its rest position. (For more information on this, see Chapter 7.3.4).

In **area 2**, the MagSpring operates with increasing force in the closing direction.



The MagSpring option is only recommended for workpieces that are gripped from the outside. This is because the clamping force support acts in the closing direction. Therefore, the MagSpring option may not be suitable for applications where the workpiece is gripped from the inside.

4.2 Side mounting of the gripper

4.2.1 Fastening the mounting adapter

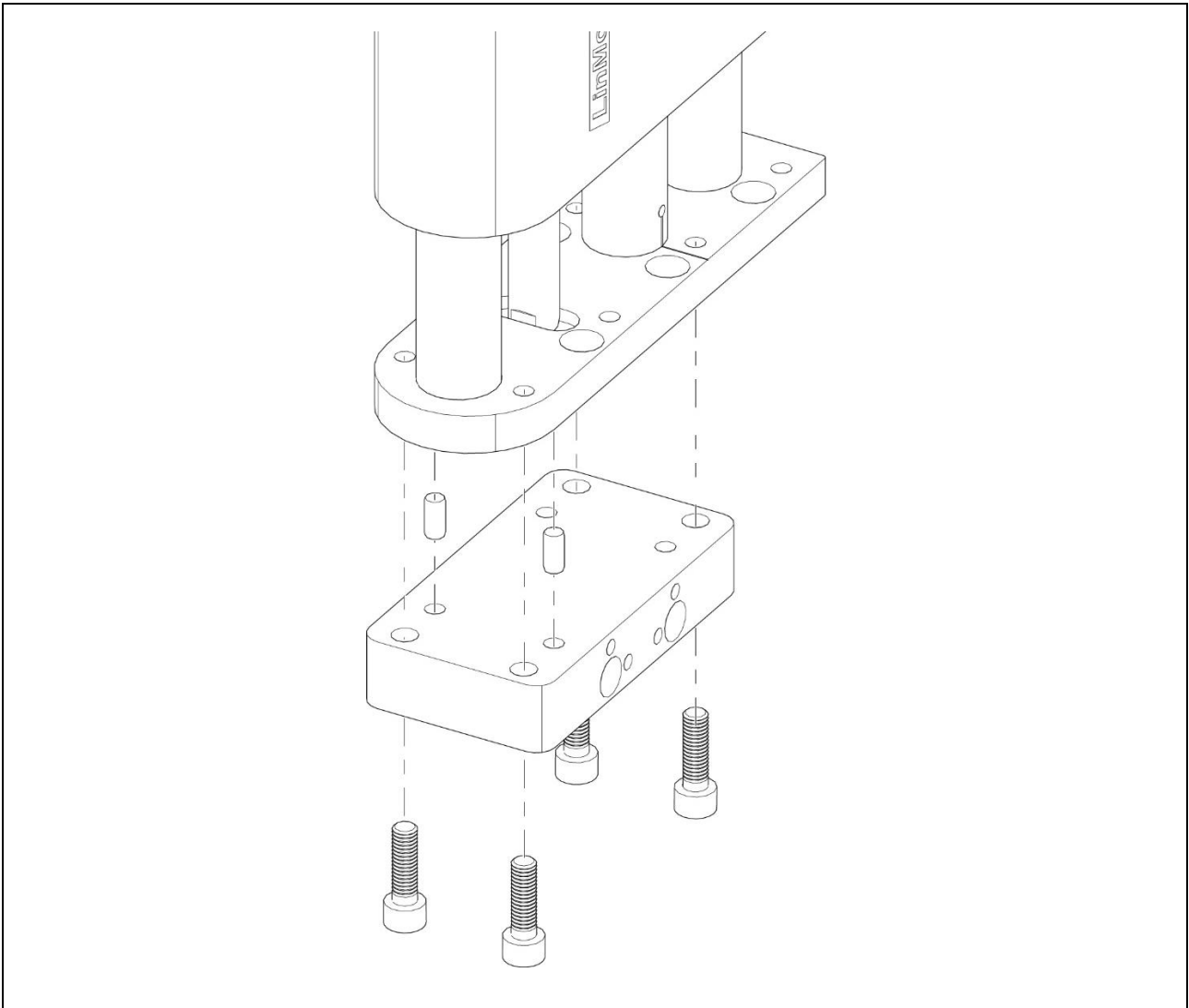

The side-mounting adapter for the GM50 gripper is attached to the end plate of the linear module using the included screws and pins.



Please note that the maximum torque must always be observed.

4.2.2 Mounting of the gripper on the left side of the module

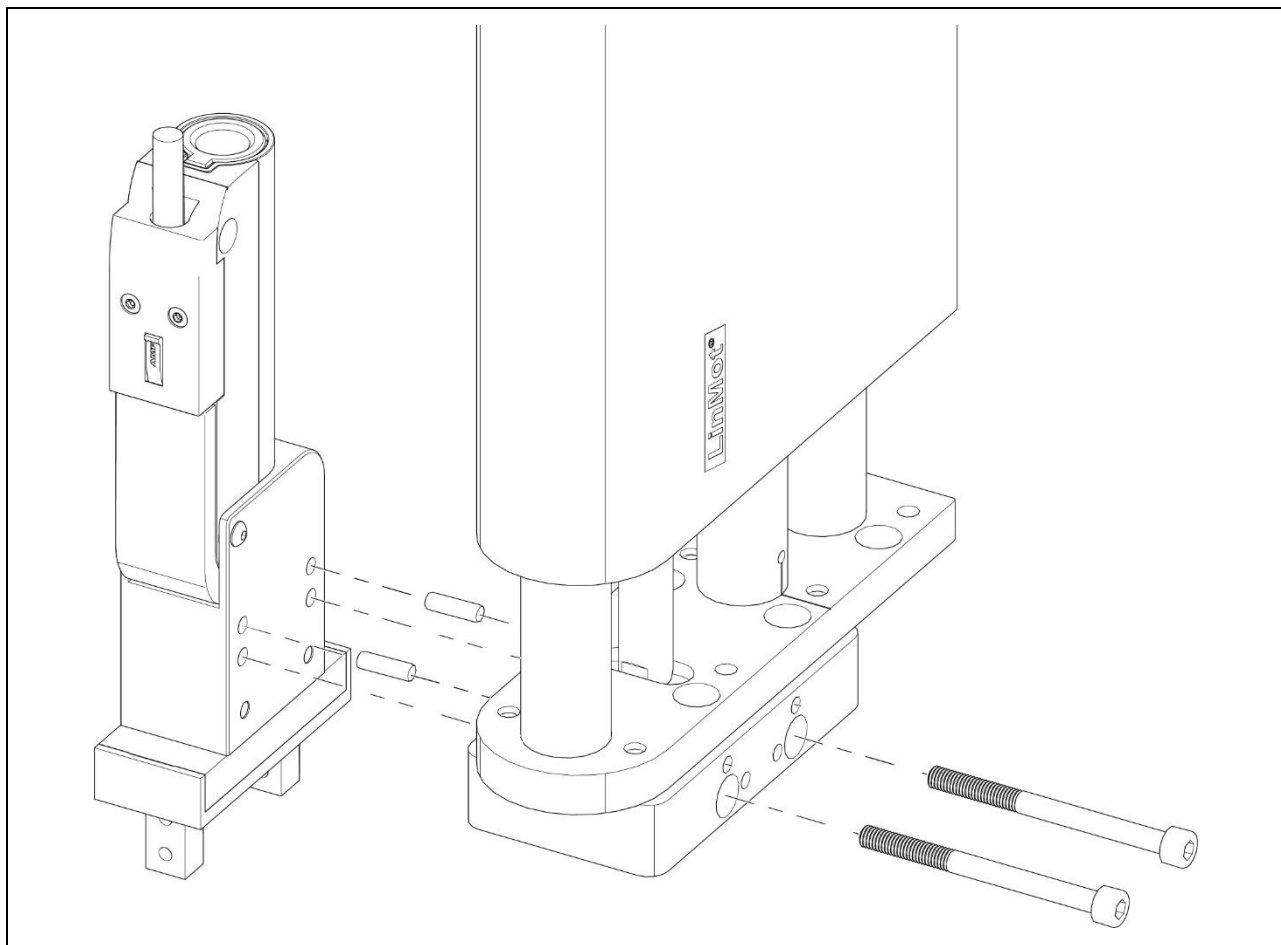

The GM50 gripper is attached to the left side of the mounting adapter using the included screws and pins.



Please note that the maximum torque must always be observed.

4.2.3 Mounting of the gripper on the right side of the gripper

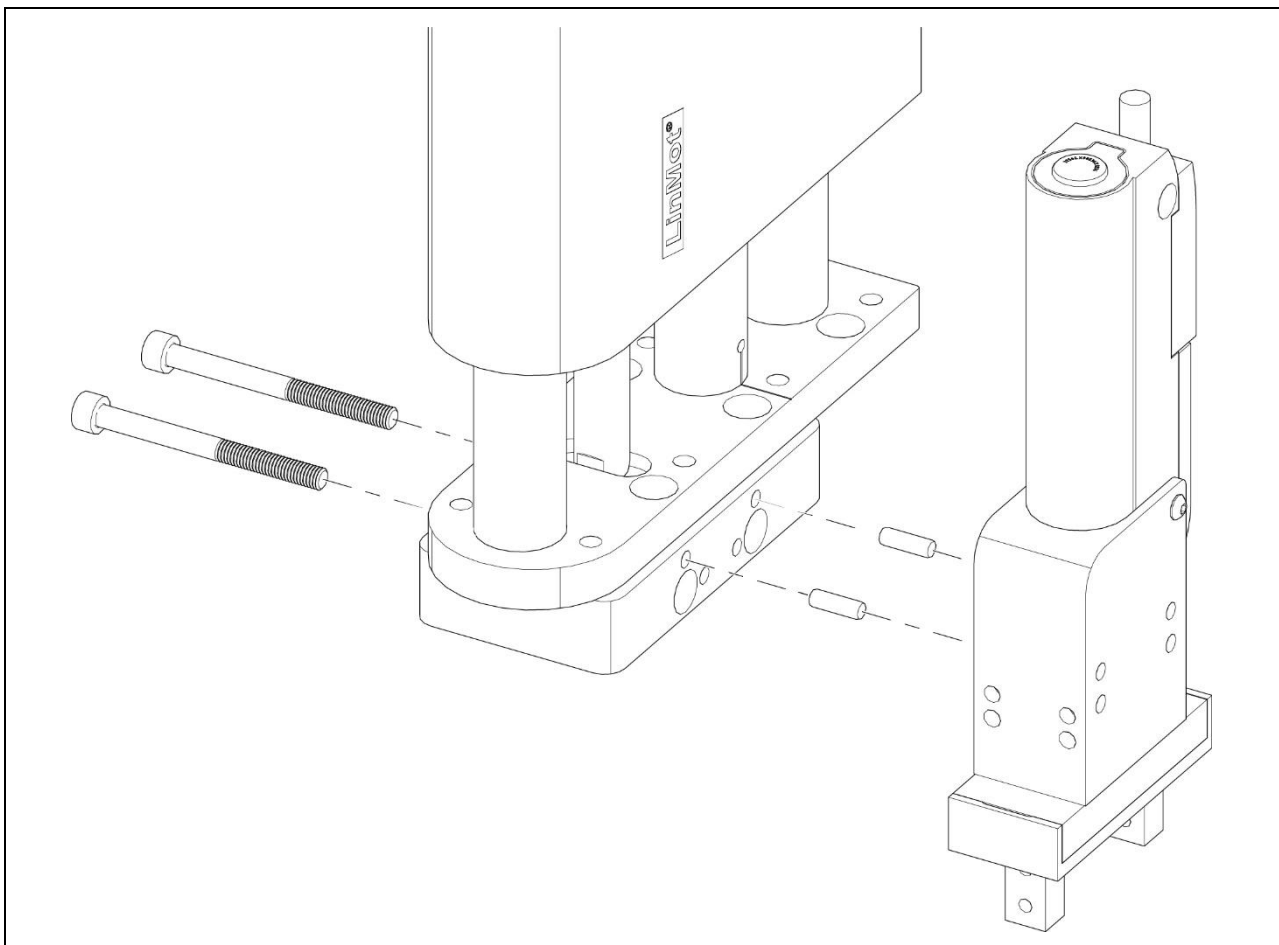

The GM50 gripper is attached to the right side of the mounting adapter using the included screws and pins.



Please note that the maximum torque must always be observed.

4.3 Frontal mounting of the gripper

4.3.1 Fastening the mounting adapter

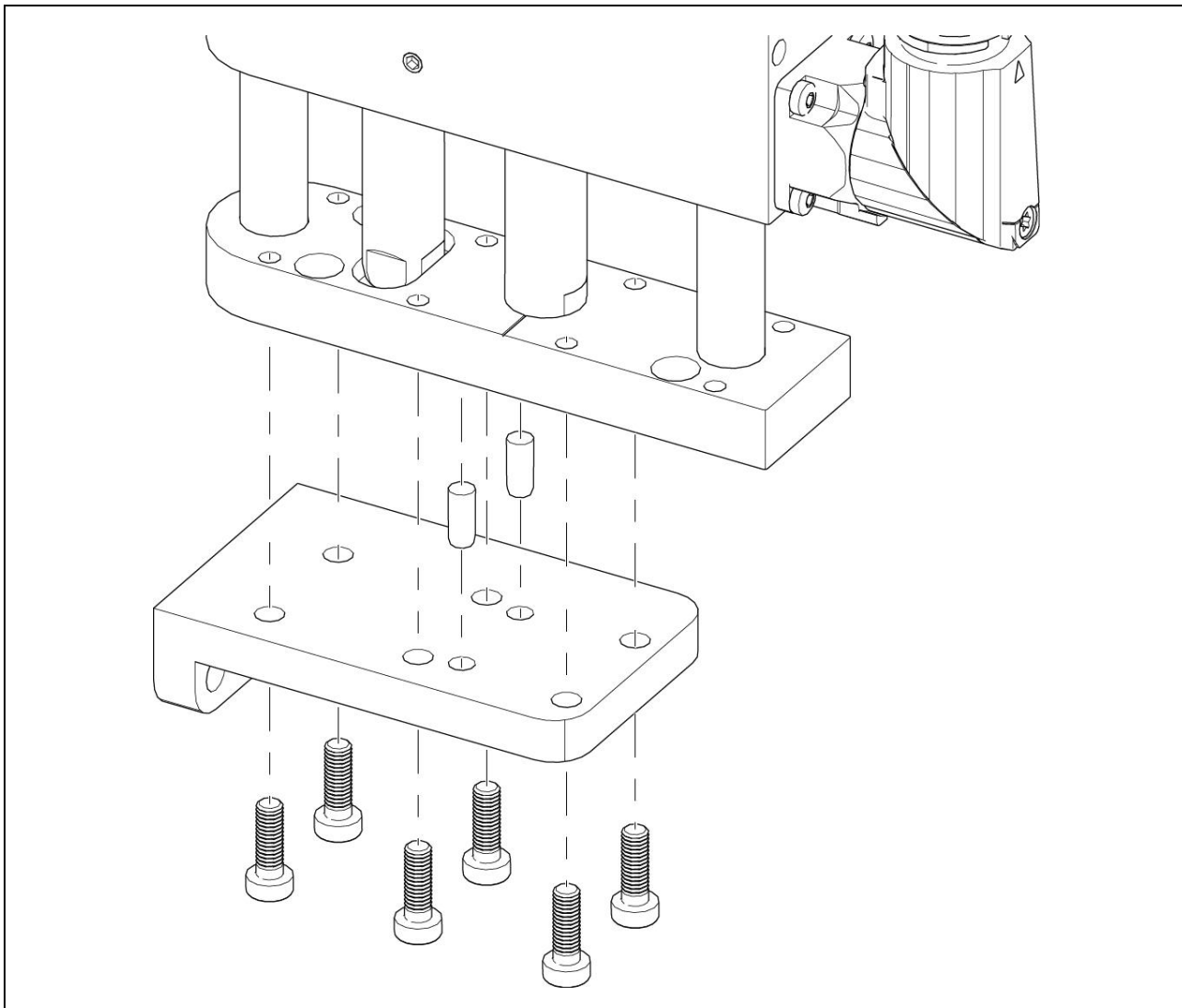

The front mounting adapter for the GM50 gripper is attached to the end plate of the linear module using the included screws and pins.



Please note that the maximum torque must always be observed.

4.3.2 Mounting of the gripper

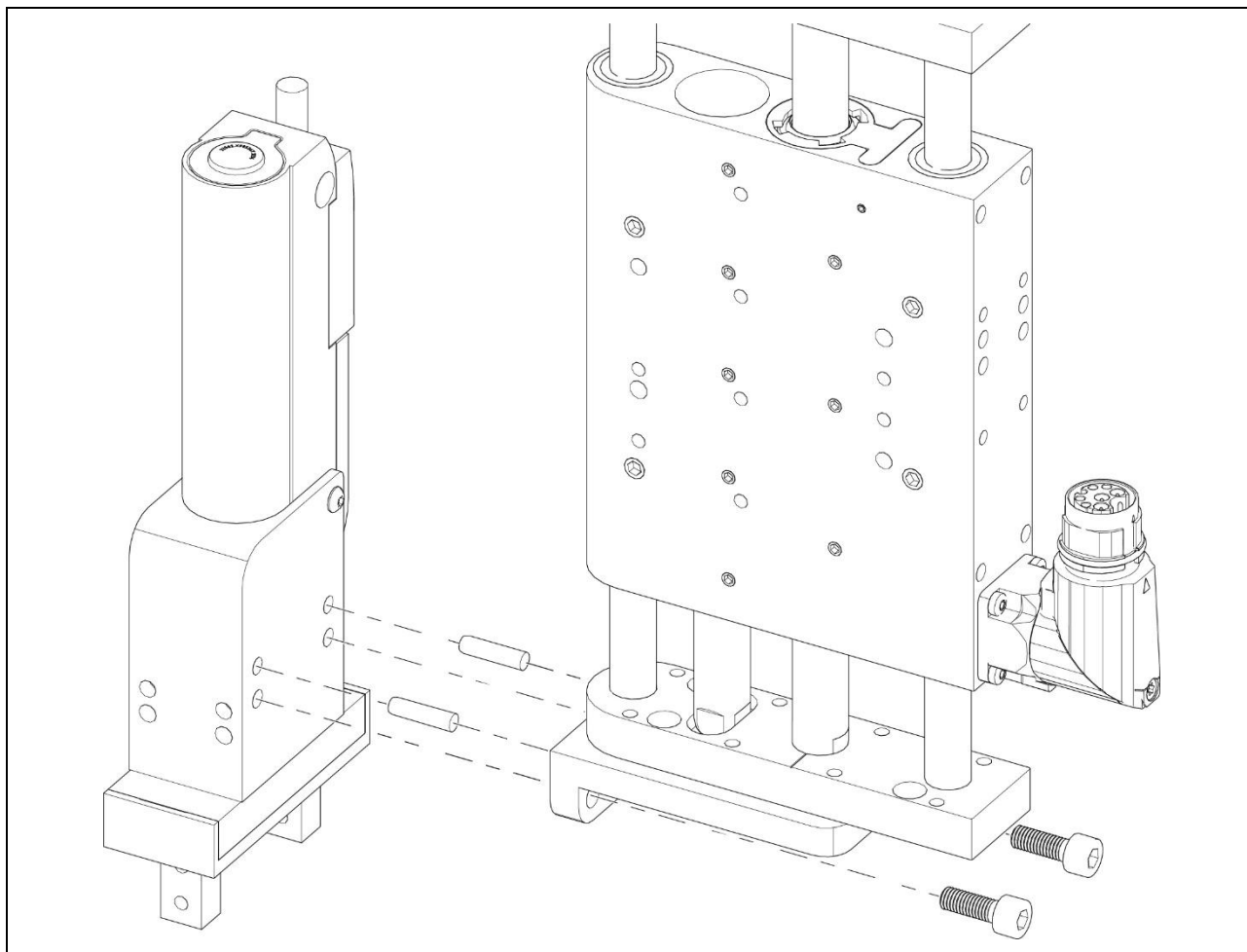

The GM50 gripper is attached to the front of the mounting adapter using the included screws and pins.



Please note that the maximum torque must always be observed.

5 Electrical Connection



Only connect or disconnect the motor connector when no voltage is applied to the servo drive. Only original LinMot cables may be used for wiring the motor. Pre-assembled cables may only be made from original LinMot accessories and must be carefully checked before commissioning.

Incorrect motor wiring can damage the motor and/or the servo drive!

5.1 Motor cable



Individual cable lengths are available **on request**.

5.1.1 Technical data

Cable type	Trailing chain cable			Robot cable
	KS03-09	KS05-09	KS05-04/05	KR03-09
Cable length	6 m*	6 m*	On request	6 m*
Cable diameter	6.7 mm (0.26 in)	7.6 mm (0.30 in)	9.5 mm (0.38 in)	7.4 mm (0.29 in)
Min. bending radius static	25 mm (0.98 in)	25 mm (0.98 in)	30 mm (1.18 in)	30 mm (1.18 in)
Min. bending radius moving	50 mm (1.97 in)	55 mm (2.17 in)	60 mm (2.36 in)	60 mm (2.36 in) Max. Torsion: ±180° pro 0.5 m**
Approval	UL / CSA 300V E172204	UL / CSA 300V E172204	UL / CSA 300V E172204	UL / CSA 300V E172204
Core insulation material	TPE-E	TPE-E	TPE-E	TPE-U
Cable jacket material	PUR			
Oil resistance	Very good according to DIN VDE 0282 Teil 10 + HD 22.10			
Chem. resistance to: acids, alkalis, solvents, hydraulic fluid	Good			
Flammability	Flame retardant			

* Maximum length: 6 m. Longer cable lengths may result in reduced positioning accuracy, poor operating performance and increased susceptibility to interference in the motors.

** ±270°/0.5m permitted for initialisation.

5.2 Mounting the motor cable



To prevent damage to the cable from vibration, the cable connection to the motor must not be subjected to alternating loads. When installing the gripper, ensure that the cable is fixed so that a minimum bending radius (see chapter 6.1.1 "Motor cable technical data") is not exceeded. In addition, the cable must not move at the motor connection.

5.2.1 GM50-23

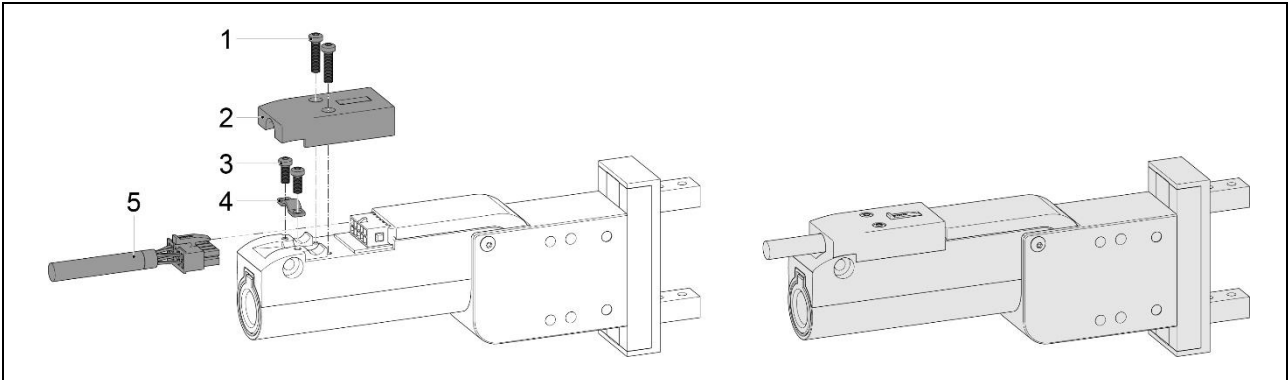

Position	Description
1	M2.5 x 12
2	Cover
3	M2.5 x 6
4	Shielding and cable relief
5	Cable with connector

5.2.2 GM50-37

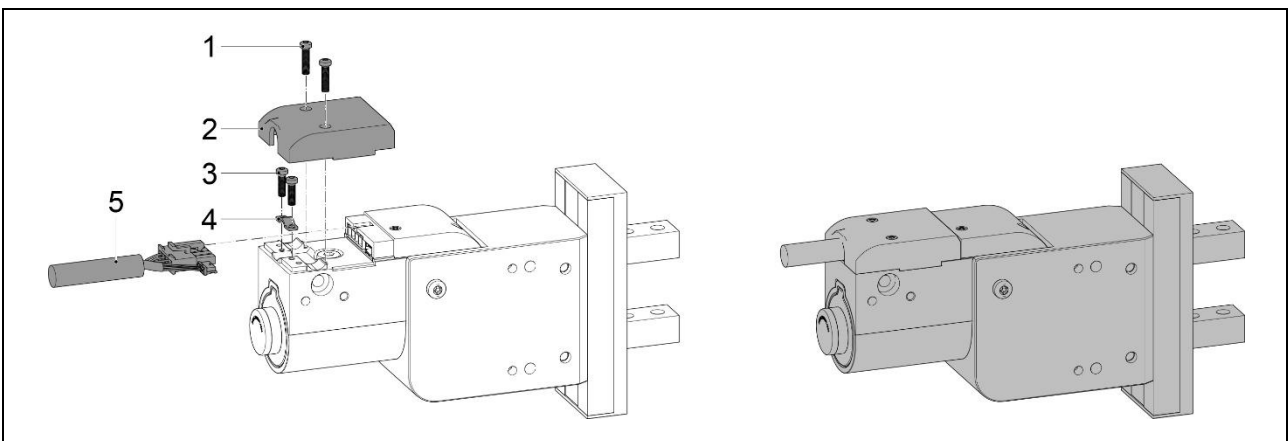

Position	Description
1	M2.5 x 12
2	Cover
3	M2.5 x 10
4	Shielding and cable relief
5	Cable with connector

5.3 Stator connector assignment

Connector type	K-connector		N-connector	
Gripper type	GM50-23		GM50-37	
	PIN	Wire	PIN	Wire
Phase1+	1	red	4	red
Phase1-	4	pink	3	pink
Phase2+	2	blue	2	blue
Phase2-	5	grey	1	grey
+5V	9	white	A	white
GROUND*	8	brown	B	inner shield
Sensor Sin.	6	yellow	C	yellow
Sensor Cos.	7	green	D	green
Temp sens	10	black	E	black
SHIELD* of stator and stator cable	Case	Shield	Gehäuse	Outer shield
Connector	<p>MC01-K/f</p>		<p>MC01-N/f</p>	

6 Calculation of the Load Moments

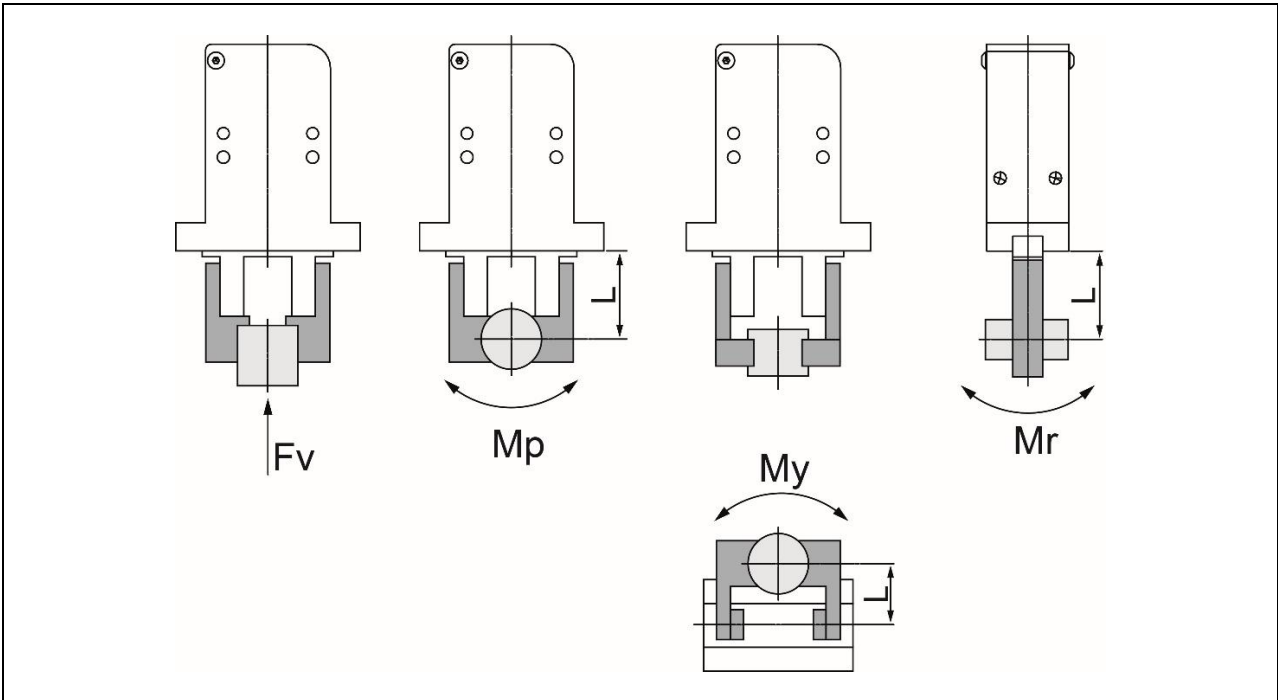

L: Distance to the point at which the load is applied (mm).

Model	Allowable vertical load Fv (N)	Maximum allowable moment		
		Pitch moment Mp (Nm)	Yaw moment My (Nm)	Roll moment Mr (Nm)
GM50-23	147	1.32	1.32	2.65
GM50-37	343	3.0	3.0	6.0

Values for load and moment in the table indicate static values.

Calculation of allowable external force (when moment load is applied)	Calculation example
$\text{Allowable load } F \text{ (N)} = \frac{M \text{ (maximum allowable moment) (N} \cdot \text{m)}}{L \times \frac{10^{-3}}{*}}$ <p>(*Unit conversion constant)</p>	<p>When a static load of = 10N is operating, which applies pitch moment to point L = 30mm from the GM50-23 guide.</p> $\text{Allowable load } F \text{ (N)} = \frac{1.32}{30 \times 10^{-3}} = 44.0 \text{ (N)}$ <p>Load f = 10 (N) < 44.0 (N) Therefore, it can be used.</p>

7 Start-up

7.1 General information



Please observe the following instructions to ensure that your LinMot GM50 or GM51 gripper works optimally and safely. The following drawings show the most important points at a glance. This will ensure that your gripper works reliably and at its best.

Note for use with and without MagSpring

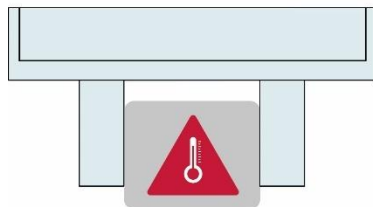

X DO NOT
press strongly for too long

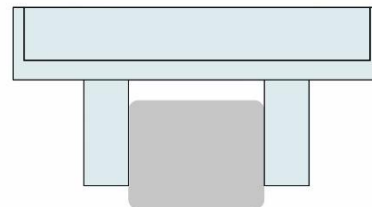

✓ DO
press strongly for short times

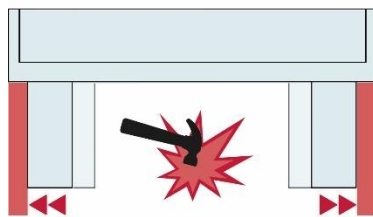

X DO NOT
move fast into mechanical stop

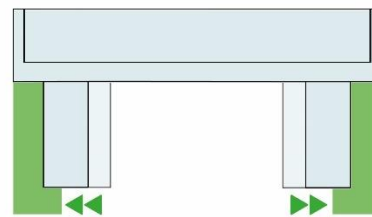

✓ DO
keep distance when moving fast
to mechanical stop

Note for use only with MagSpring

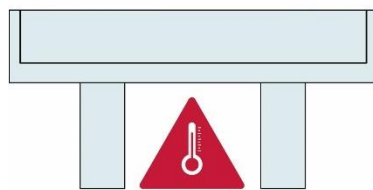

X DO NOT
park gripper fingers in the middle
for too long

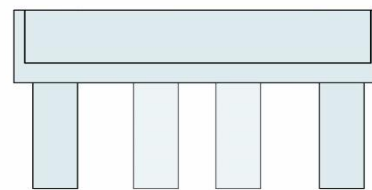

✓ DO
park gripper fingers as shown in
installation guide



- With the MagSpring option, force is exerted across the stroke range in the closing direction. The parking position must be selected so that the force exerted by the MagSpring is low. This is to prevent the gripper from overheating. Suitable parking and gripping positions can be found in the relevant diagrams of the data sheet.
- The maximum gripping force should only be applied for a short time. Once the workpiece has been gripped successfully, the force must either be reduced to the nominal force or the workpiece must be released completely.
- When approaching the mechanical stops and when positioning and parking the gripping jaws, a distance of 0.2 mm must be maintained from the mechanical stops.

7.2 Setting the parameters



To configure the gripper, use the LinMot-Talk software from version 6.13. The software and the associated detailed user manual can be downloaded from <https://linmot.com/download/linmot-talk-drive-configuration/>

7.3 Plug-and-Play

LinMot gripper are plug and play. This means that they automatically log on to the drive. The module and motor specific parameters are automatically stored in the drive and the motor is ready for use.

If the motor file is not automatically found in the installation directory of the software, the file can be downloaded using the LinMot-Talk software, as shown below.

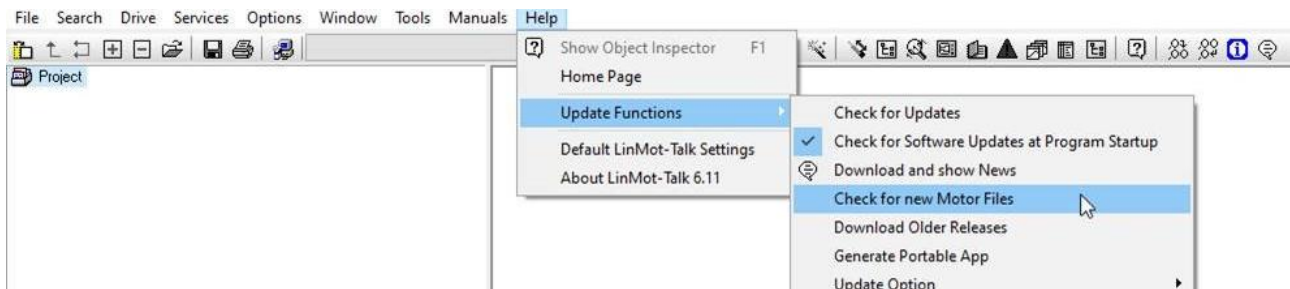

7.3.1 Application-specific parameters

Application specific parameters such as cable length, load mass, PID control settings etc. can be entered by the user via the Motor Wizard. Click on the Motor Wizard icon in the task bar of the LinMot-Talk software.

The Motor Wizard will guide the user through the menu step by step. The application parameters should be entered as accurately as possible to ensure the best possible motor control.

7.3.2 Referencing the gripper

The built-in linear motor has a position detection system that must be referenced. Several modes are available to the user for this purpose. Depending on the mode selected, the linear motor will, for example, search for a mechanical stop in the open or closed position.

The gripper must be referenced once, for example by a mechanical stop, to determine its position. Homing can then be switched off, as the reference point remains in place. **Note:** If the slider is removed, the reference is lost and the gripper must be referenced again.

7.3.3 Current/force limitation of the gripper

The actuators are controlled by position specification as standard. If the actuator hits a mechanical stop or something gets in the way, the actuator will apply the maximum force/current to hold the position or follow the target position. The high current drawn over a long period of time will cause the actuator to heat up or overheat. For this reason the current consumption should be limited in certain cases:

- Positioning on a fixed stop
- Gripping hard products
- Gripping sensitive products

Control example for smooth gripping

Before gripping, the gripping fingers are in the park position (rest position), in which the gripper is open and not under the influence of the MagSpring force. Without the MagSpring option, any position can be considered the park position. To grip, the gripper fingers are moved to the gripping position with the desired movement parameters and set current limit. The gripper fingers then press onto the object being gripped with the set current limit. The force acting on the gripper fingers can be found in the force/position diagram. The gripper is released by returning to the park position from the current gripping position.

Current limitation in LinMot-Talk

Function	Parameter	UPID
Bi-directional current limit	Maximal Current	13A6h
Positive current limit	Maximal Current Positive	13FCh
Negative current limit	Maximal Current Negative	13FDh

7.3.4 Gripper rest position with MagSpring load compensation option

The gripper should ideally be set to the outermost position when at rest. In this position, the acting force is minimal, which is the most favorable condition.

Alternatively, the gripper can be set to the innermost position. Although the MagSpring exerts its maximum force here, this force is effectively absorbed by the mechanical stop, preventing negative effects.

A middle position between the inner and outer limits should be avoided. In this case, a continuous force from the MagSpring acts on the gripper, which can result in undesirable heating and potentially impact performance or longevity.

8 Parameters

8.1 Motor position/gripper finger position ratio

The linear motor movement is converted into gripper movement via a lever mechanism. The transmission ratio of the motor position to the gripper position is stored for each gripper and can be read from the corresponding parameters.

Example:

To open the GM50-23 gripper fingers by 10 mm, the motor must be moved by 4.7077 mm (10 mm / 2.1242).

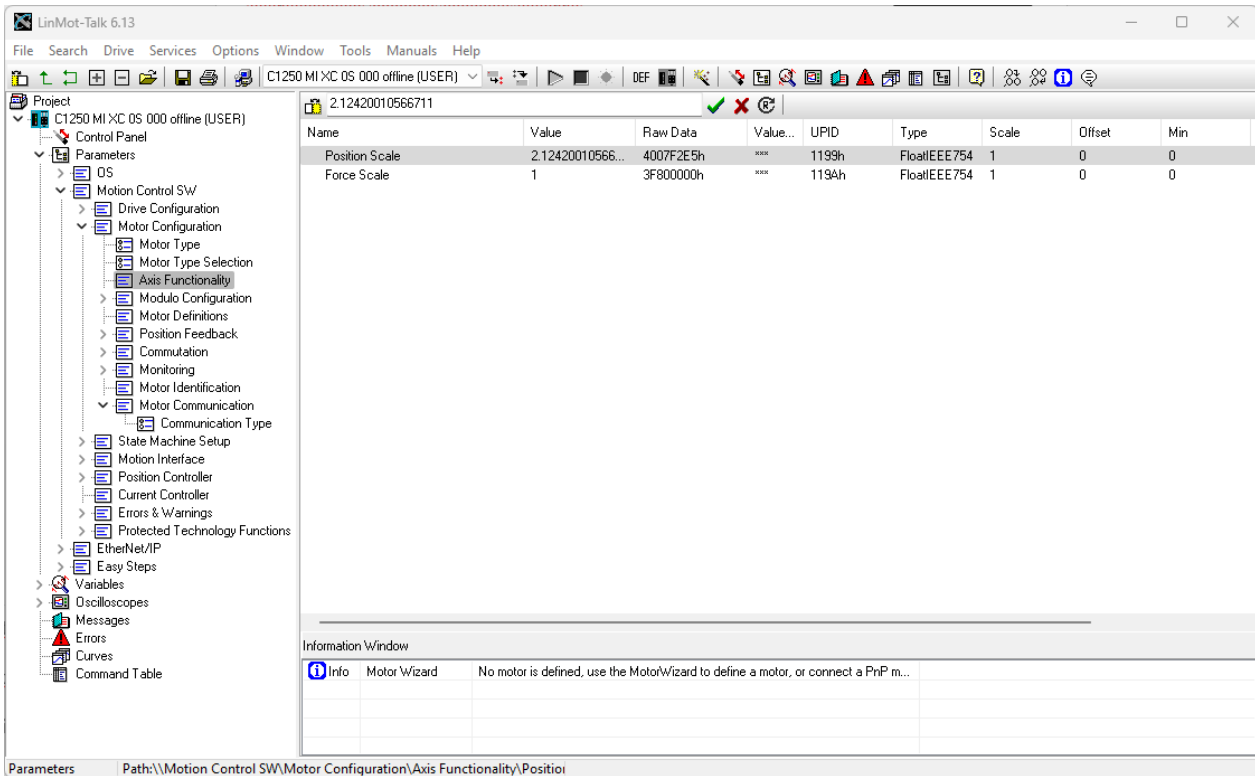

Function	Parameter	UPID
Transmission ratio motor position to gripper position	Position Scale	1199h
Transmission ratio motor force to gripper force	Force Scale	119Ah

A factor of 1 means a transmission ratio of 1:1, or that the factor is not used. For force transmission using the MagSpring option, refer to the force-position ratio diagrams in the datasheet.

Item-Nr.	Item	Position Scale	Force Scale
0150-6418	GM50-23Sx80F-XP-K_35-18	2.12420010566711	1
0150-6251	GM50-23Sx80F-XP-K_35-18_MS03	2.12420010566711	1
0150-6632	GM50-23Sx160H-XP-K_35-18	2.12420010566711	1
0150-6631	GM50-23Sx160H-XP-K_35-18_MS03	2.12420010566711	1
0150-6596	GM50-37Sx60-XP-N_48-22	1.71875	1
0150-6255	GM50-37Sx60-XP-N_48-22_MS03	1.71875	1
0150-6656	GM50-37Sx120F-XP-N_48-22	1.71875	1
0150-6657	GM50-37Sx120F-XP-N_48-22_MS03	1.71875	1

9 Accessories

9.1 Motor cable GM50-23

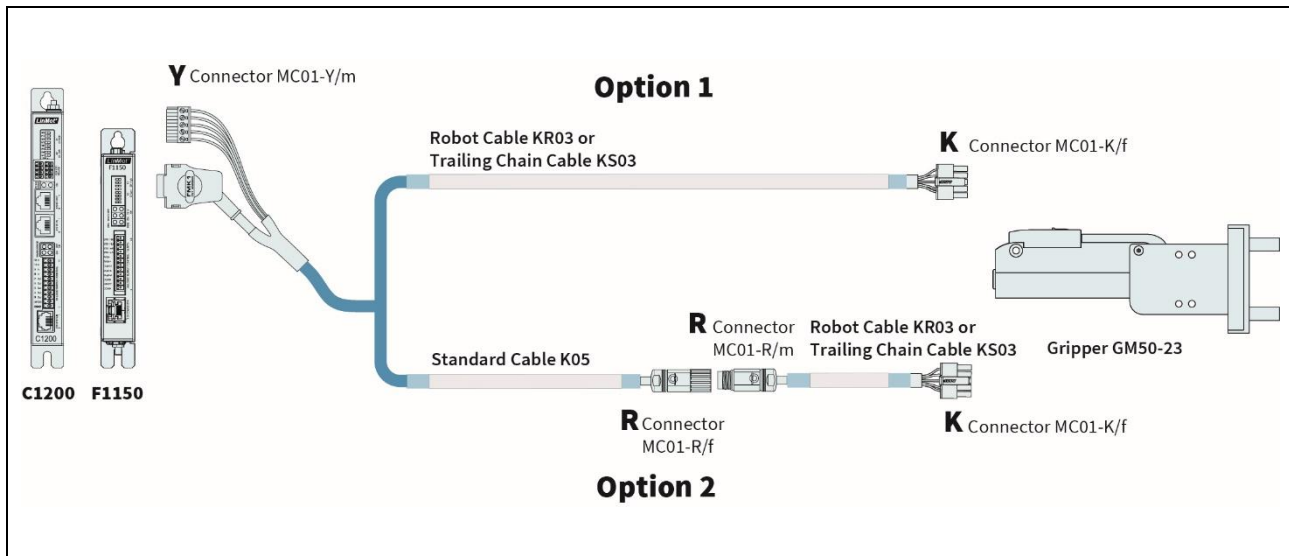

Option 1: Motor cable for direct connection

Item	Description	Item-No.
KS03-Y-Fe/K-2	Trailing chain cable Y-Fe/K, 2 m	0150-2446
KS03-Y-Fe/K-4	Trailing chain cable Y-Fe/K, 4 m	0150-2447
KS03-Y-Fe/K-6	Trailing chain cable Y-Fe/K, 6 m	0150-2448
KS03-Y-Fe/K-	Trailing chain cable Y-Fe/K, Custom length (max. 6 m)	0150-3516
KR03-Y-Fe/K-	Robot cable Y-Fe/K, Custom length (max. 6 m)	0150-3718

Option 2: Motor cable for indirect connection with extension cable

Item	Description	Item-No.
K05-Y/R-2	Motor cable Y/R, 2 m	0150-2421
K05-Y/R-4	Motor cable Y/R, 4 m	0150-2422
K05-Y/R-6	Motor cable Y/R, 6 m	0150-2423
K05-Y/R-8	Motor cable Y/R, 8 m	0150-2424
K05-Y/R-	Motor cable Y/R, Custom length	0150-3501
KS03-R/K-1	Trailing chain cable R/K, 1 m	0150-2185
KS03-R/K-2	Trailing chain cable R/K, 2 m	0150-2186
KS03-R/K-4	Trailing chain cable R/K, 4 m	0150-6789
KS03-R/K-6	Trailing chain cable R/K, 6 m	0150-6790
KS03-R/K-	Trailing chain cable R/K, Custom length	0150-3530
KR03-Y-Fe/K-	Robot cable R/K, Custom length	0150-3754

9.2 Motor cable GM50-37

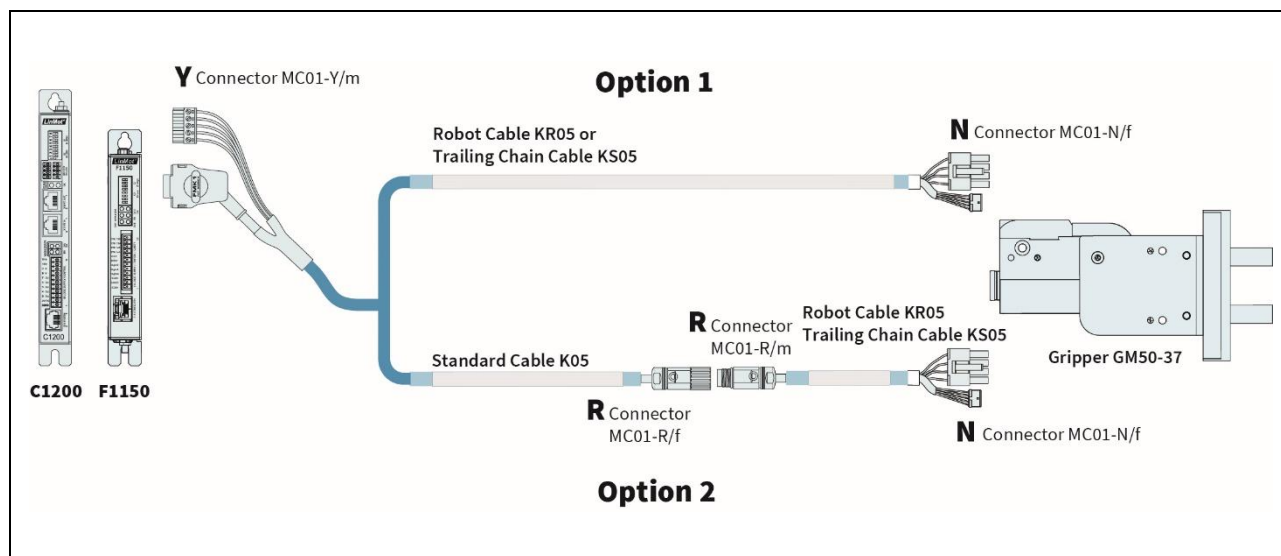

Option 1: Motor cable for direct connection

Item	Description	Item-No.
KS05-Y/N-2	Trailing chain cable Y/N, 2 m	0150-2119
KS05-Y/N-4	Trailing chain cable Y/N, 4 m	0150-2459
KS05-Y/N-6	Trailing chain cable Y/N, 6 m	0150-2120
KS05-Y/N-8	Trailing chain cable Y/N, 8 m	0150-2121
KS05-Y-Fe/N-	Trailing chain cable Y/N, Custom length	0150-2122
KR05-Y-Fe/N-	Robot cable Y/N, Custom length	0150-2132

Option 2: Motor cable for indirect connection with extension cable

Item	Description	Item-No.
K05-Y/R-2	Motor cable Y/R, 2 m	0150-2421
K05-Y/R-4	Motor cable Y/R, 4 m	0150-2422
K05-Y/R-6	Motor cable Y/R, 6 m	0150-2423
K05-Y/R-8	Motor cable Y/R, 8 m	0150-2424
K05-Y-Fe/R-	Motor cable Y/R, Custom length	0150-3501
KS05-09-R/N-1.5	Trailing chain cable R/N, 1,5 m	0150-3880
KS05-09-R/N-2	Trailing chain cable R/N, 2 m	0150-3881
KS05-09-R/N-3	Trailing chain cable R/N, 3 m	0150-3882
KS05-09-R/N-4	Trailing chain cable R/N, 4 m	TBD
KS05-09-R/N-6	Trailing chain cable R/N, 6 m	TBD
KS05-09-R/N-	Trailing chain cable R/N, Custom length	0150-3889
KR05-R/N-	Robot cable R/N, Custom length	0150-3757

9.3 Trailing chain kit GM50-23



The nuts fastening the trailing chain to the gripper's housing cover must be additionally secured (e.g. with Loctite). If they are not secured in this way, the nuts can come loose and fall into the motor.



Item	Description	Item-No.
GM50-23-TC-16x12.5	Trailing chain kit for gripper GM50-23	0150-6438

9.3.1 Dimensions

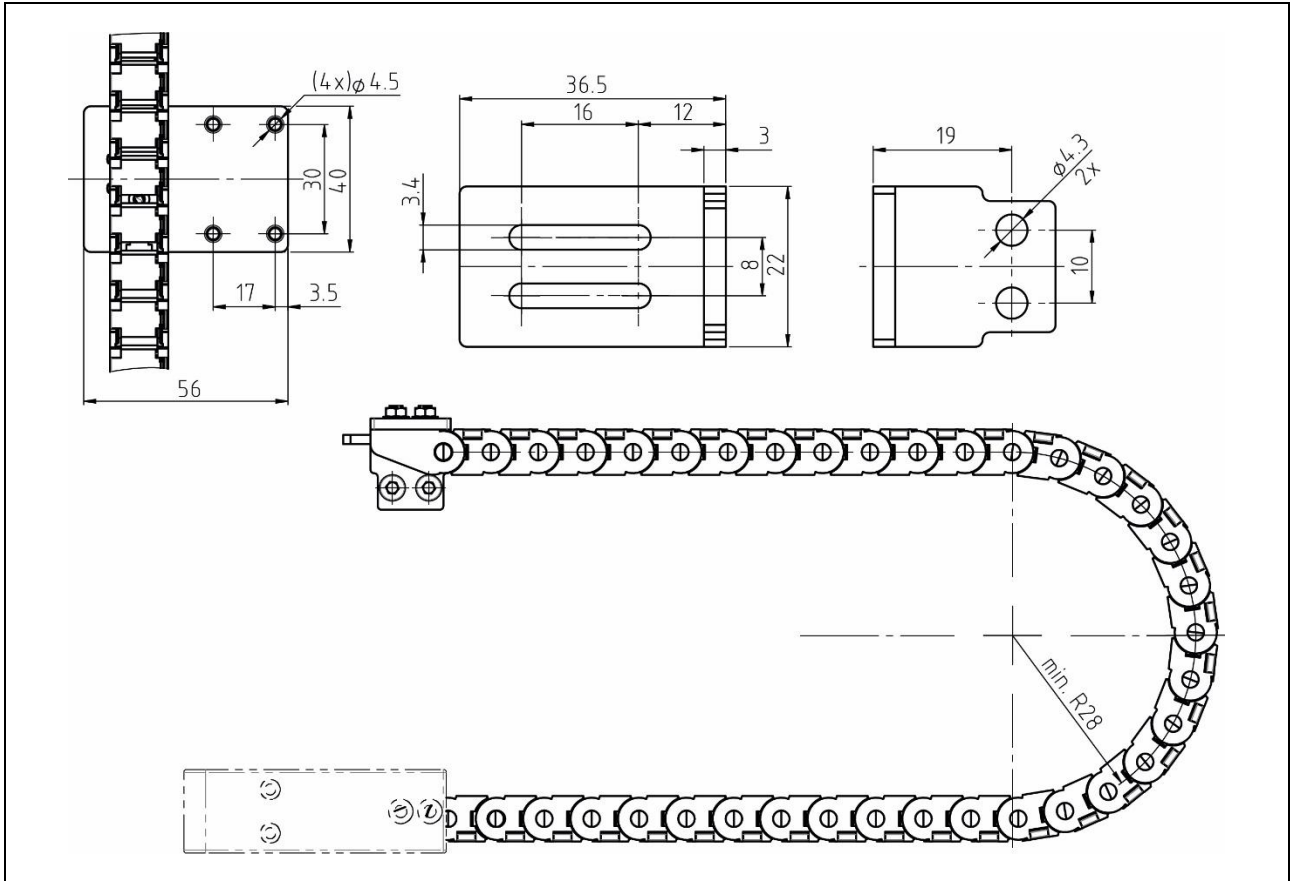

9.3.2 Overview trailing chain kit

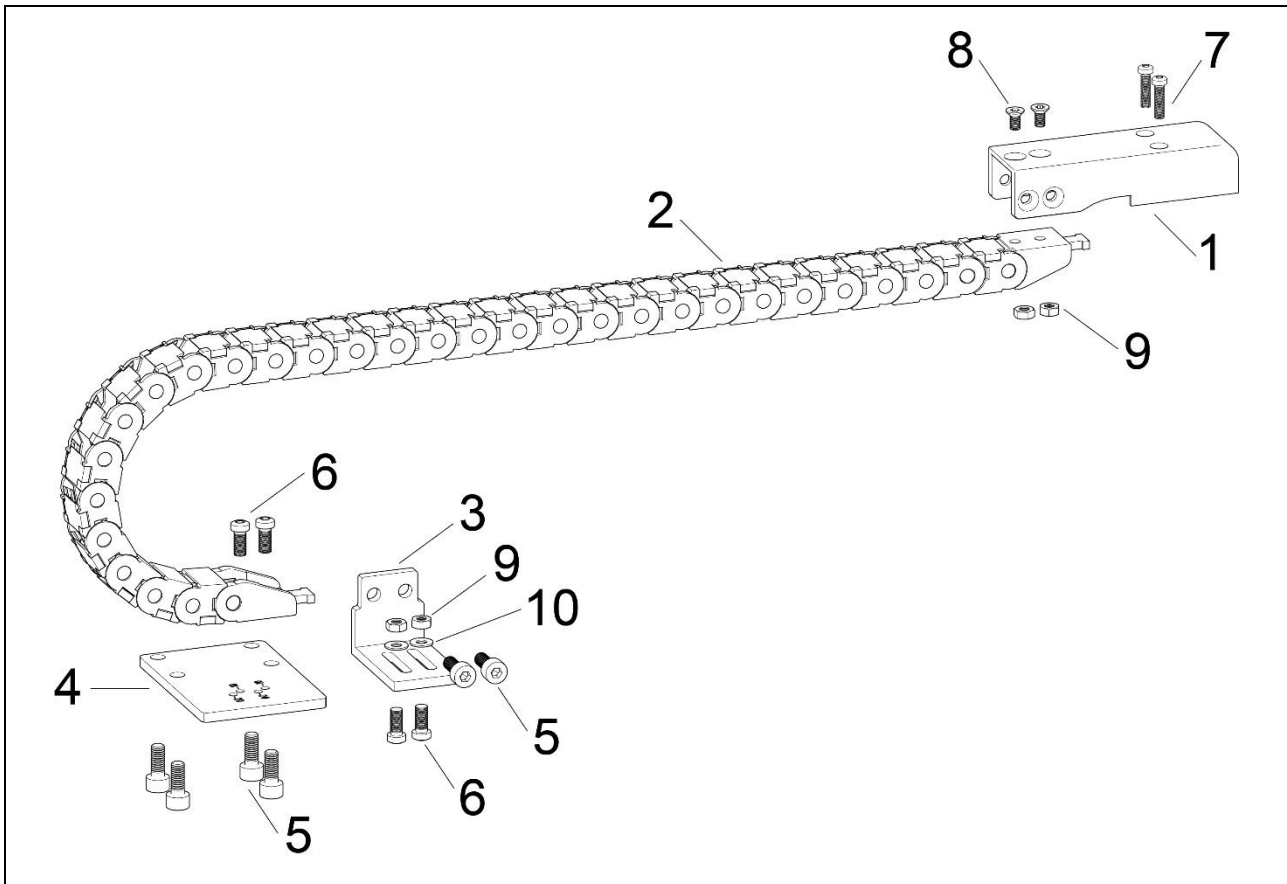

Pos.	Item
1	Connector cover with trailing chain adapter
2	Trailing chain
3	Trailing chain angle plate
4	Trailing chain plate for DM03-23
5	Socket head cap screw with hexagon socket without shaft M4x10 / ISO 4762
6	Oval head screw with hexagon socket without shaft M3 x 8 / ISO 14583
7	Oval head screw with hexagon socket without shaft M2.5 x 16 / ISO 14583
8	Hexagon socket countersunk head screw without shaft M3x6 / ISO 14581
9	Hexagon nut M3/ISO 4032
10	Non-chamfered washer / ISO 7089

9.4 Trailing chain kit GM50-37



The nuts fastening the trailing chain to the gripper's housing cover must be additionally secured (e.g. with Loctite). If they are not secured in this way, the nuts can come loose and fall into the motor.



Item	Description	Item-No.
GM50-37-TC-21x12.5	Trailing chain kit for gripper GM50-37	0150-6586

9.4.1 Dimensions

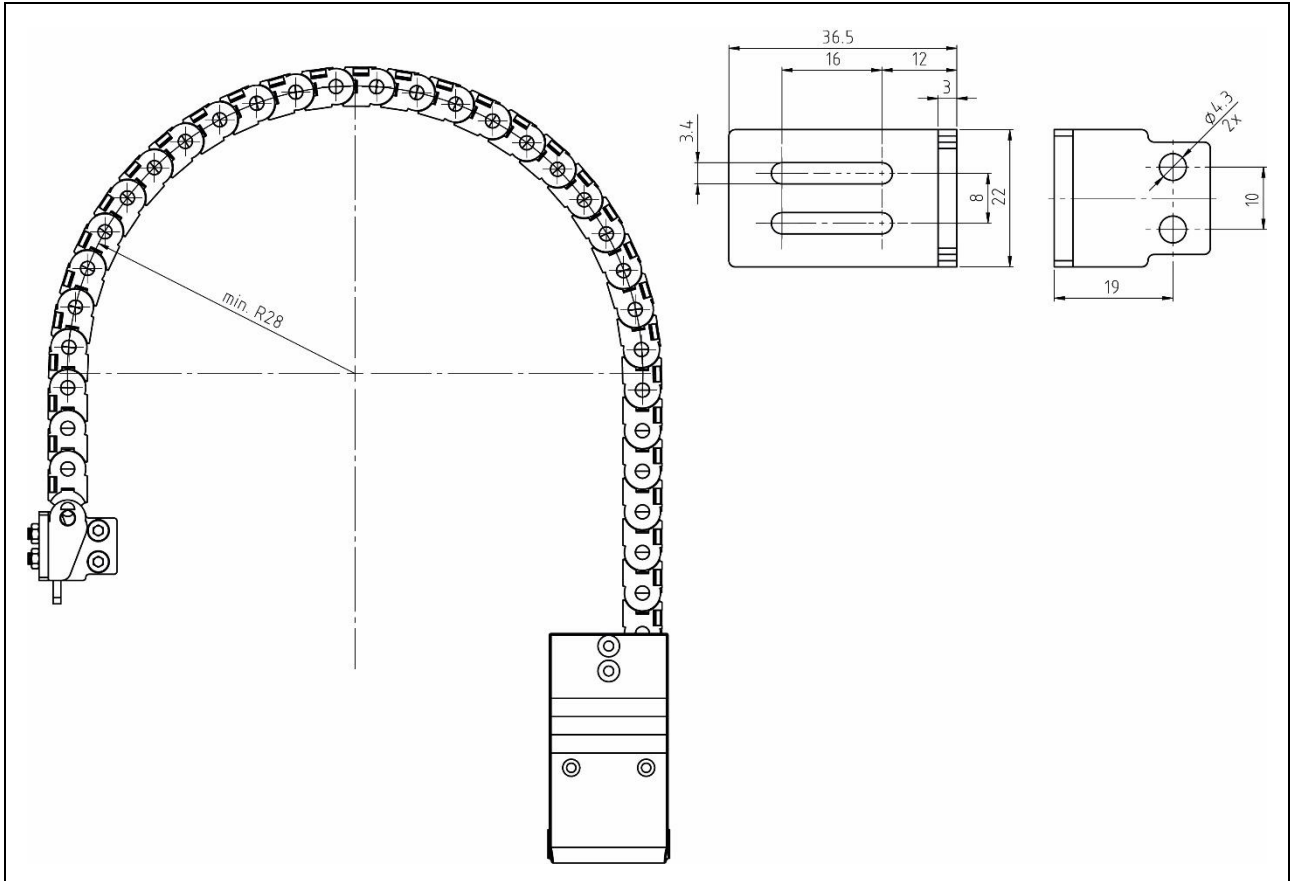

9.4.2 Overview trailing chain kit

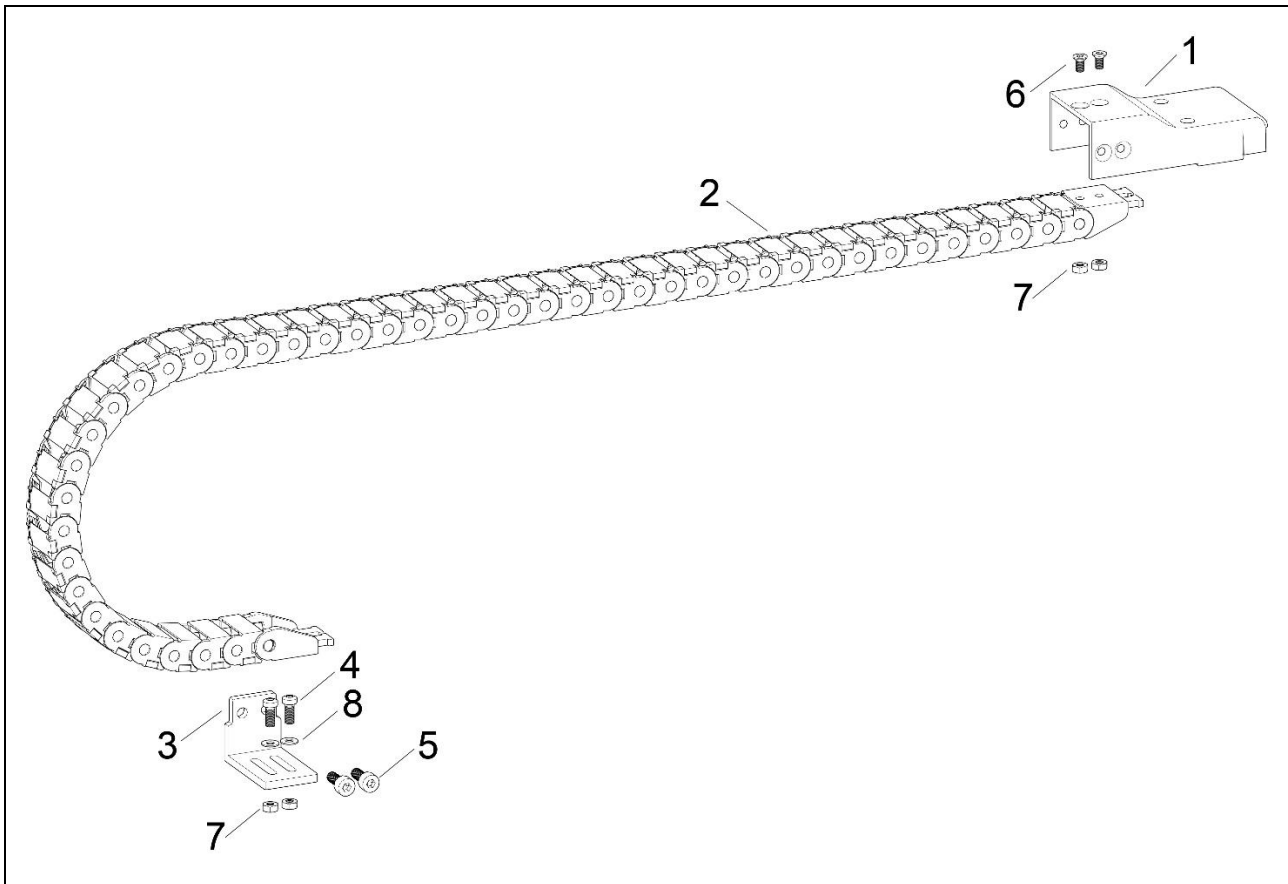

Pos.	Artikel
1	Connector cover with trailing chain adapter
2	Trailing chain
3	Trailing chain angle plate
4	Socket head cap screw with hexagon socket without shaft M4x10 / ISO 4762
5	Oval head screw with hexagon socket without shaft M3x8 / ISO 14583
6	Hexagon socket countersunk head screw without shaft M3x6 / ISO 14581
7	Hexagon nut M3/ISO 4032
8	Non-chamfered washer / ISO 7089

9.5 Mounting adapter GM50-23

9.5.1 Adapter for side mounting

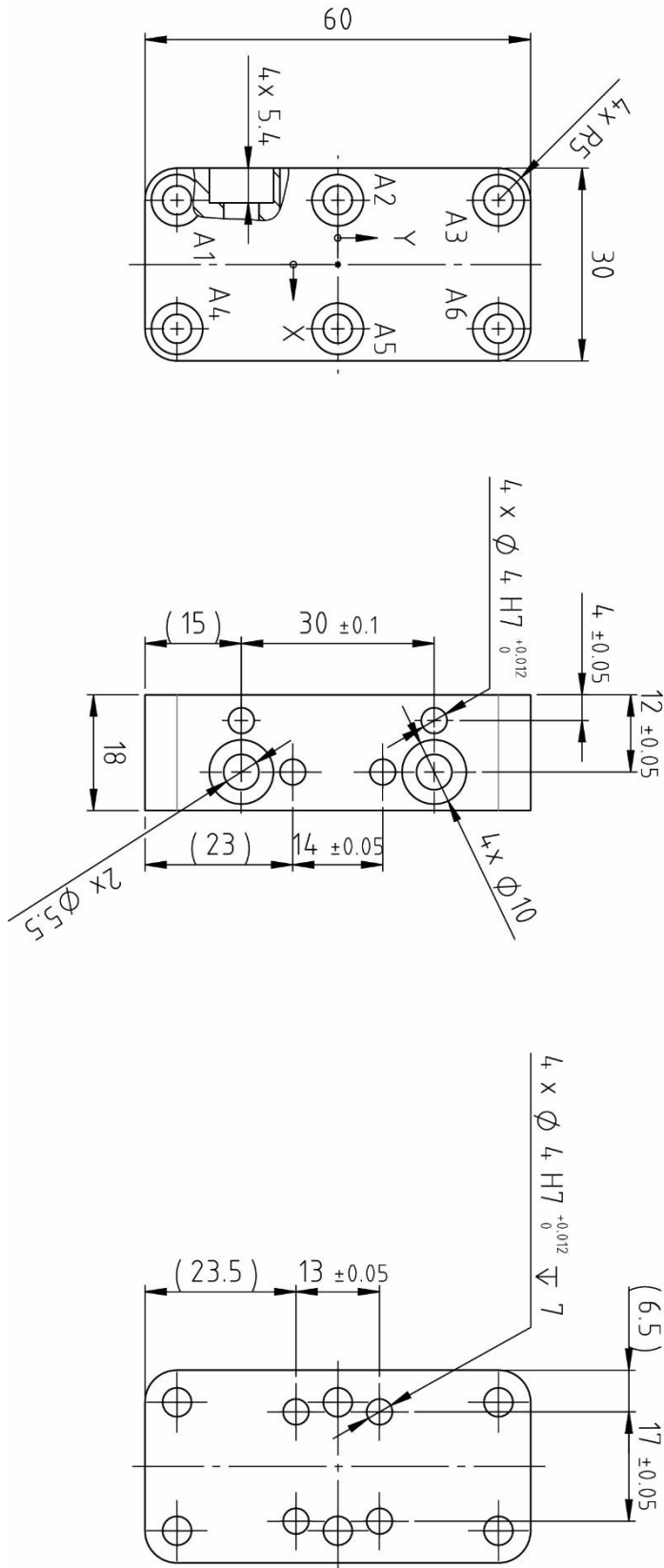

	X-POS.	Y-POS.	SIZE
A1	-10	-25	\square ϕ 4.5 \square ϕ 8 ∇ 4.4
A2	-10	0	
A3	-10	25	
A4	10	-25	
A5	10	0	
A6	10	25	

Surface:
 Anodizing, colorless 15-20µm

∇ Ra 3.2

$\begin{matrix} +0.3 \\ +0.2 \\ -0.3 \\ -0.2 \end{matrix}$

9.5.2 Adapter for frontal mounting

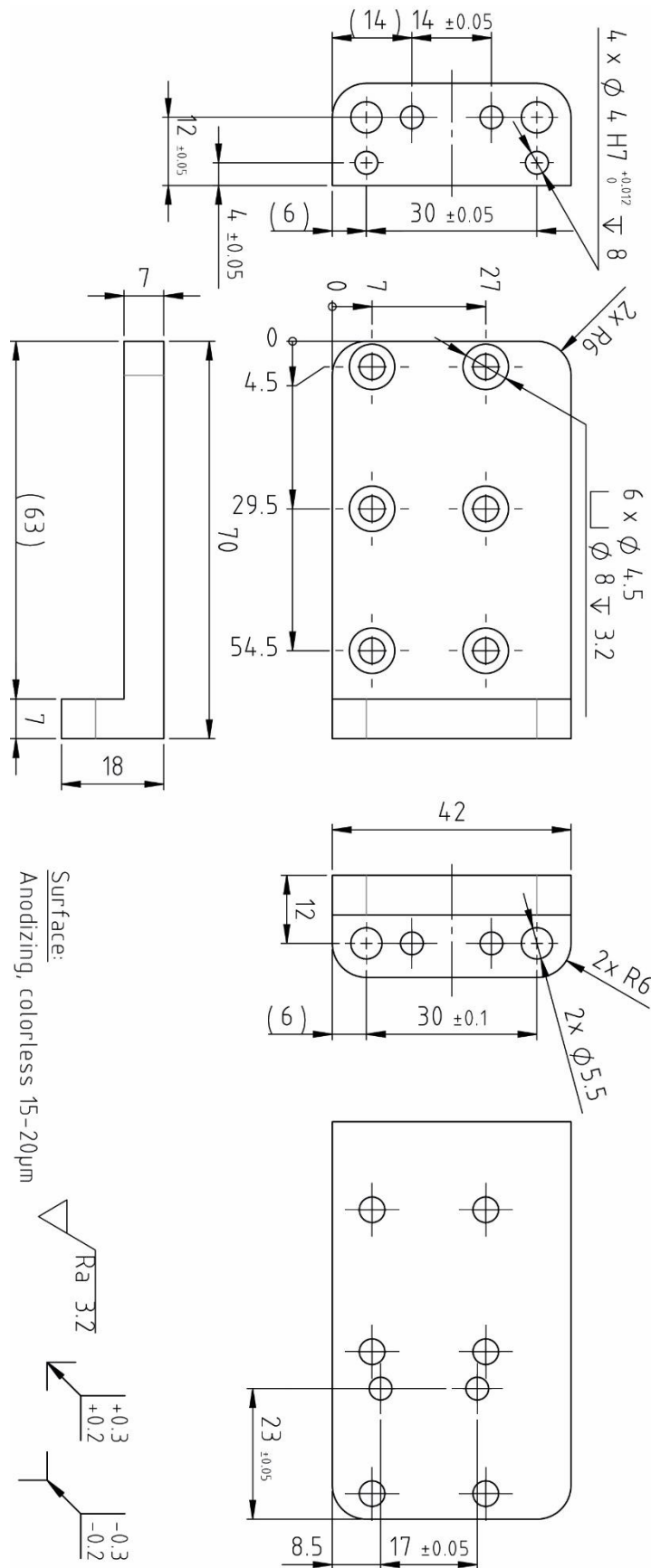

9.6 Mounting adapter GM50-37

9.6.1 Adapter for side mounting

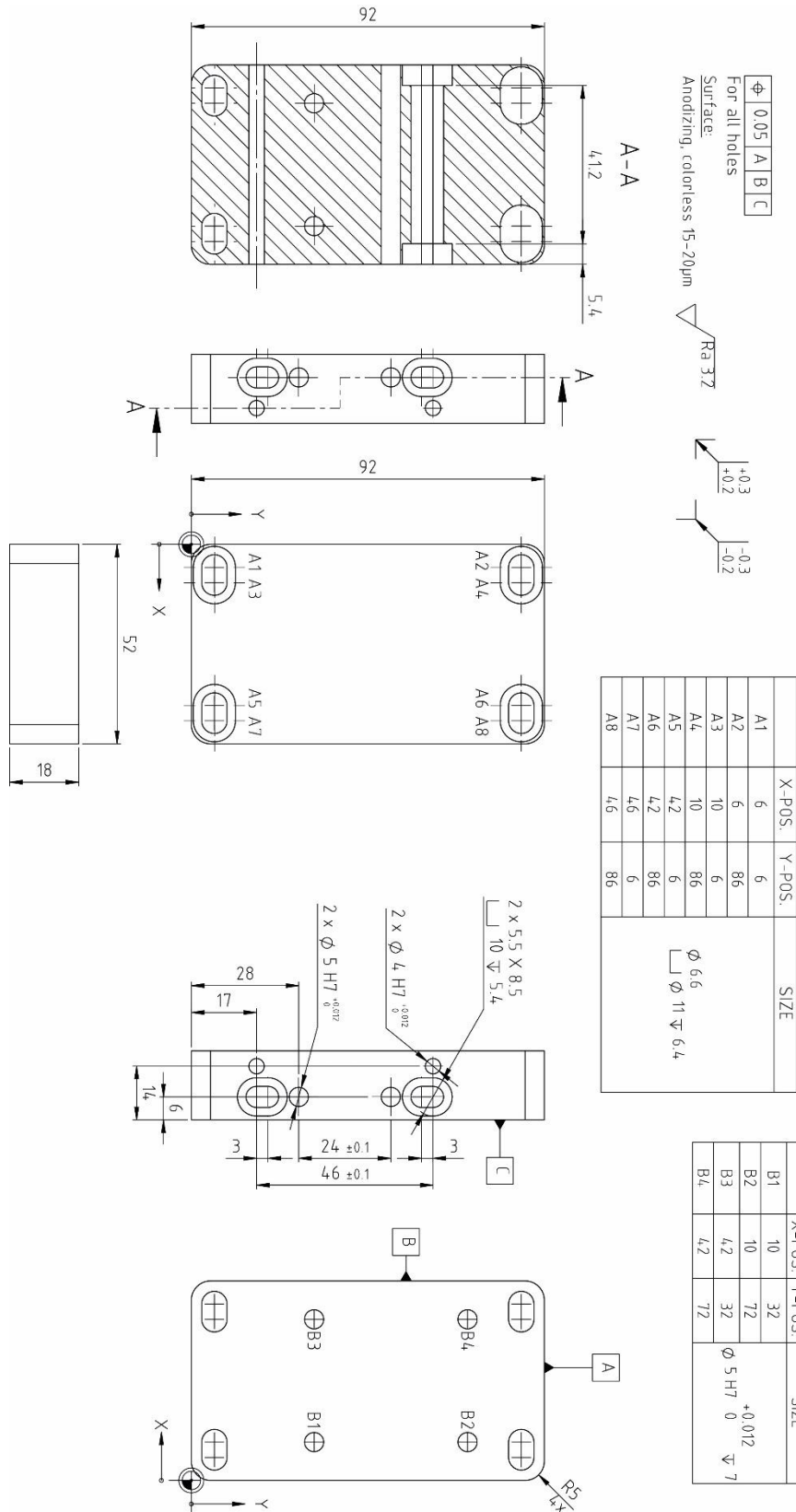

9.6.2 Adapter for frontal mounting

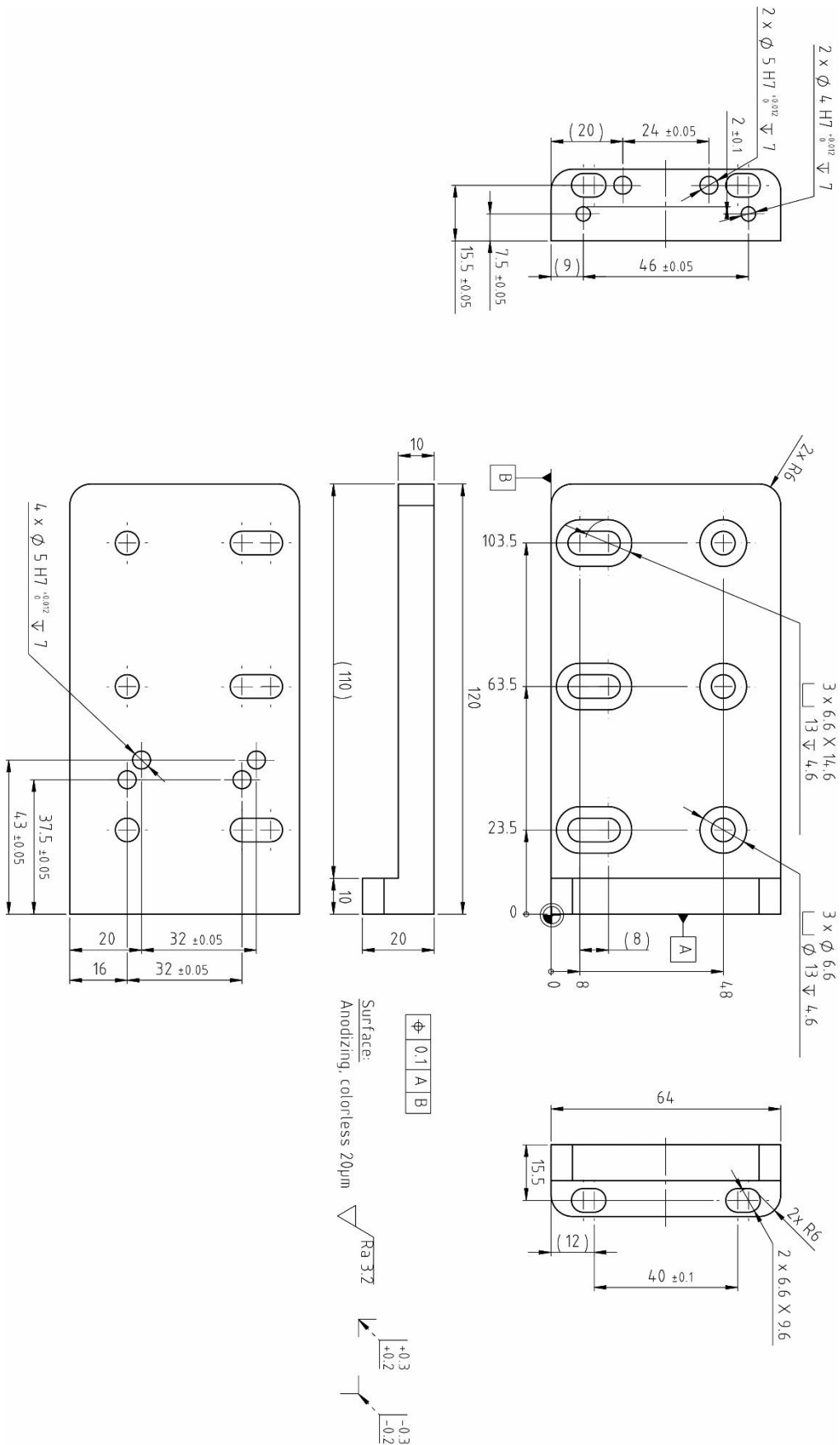

10 Maintenance

10.1 Maintenance cycles of the gripper

The plain bearings of the GM50 gripper are provided with initial lubrication at the factory. The lubrication and inspection intervals depend primarily on the average moving speed, the operating temperature and the general ambient conditions. The following table with the inspection intervals is based on normal industrial, Central European conditions (5-day week with 8 hours operating time per day) and the use of the recommended bearing grease LU04.

Gripper module with plain bearings

Velocity [v]	Inspection interval [cycles]
$v < 1$ m/s	14.3 Mio.

Basically, the inspection cycle of the actuator unit must be shortened if there are heavy loads or deviating conditions. These are e.g.:

- Permanent soiling
- Direct sunlight
- Low humidity
- Outdoor operation
- Increased operating temperature
- Strong shocks or vibrations



It is recommended that inspection, assembly and disassembly of the gripper modules be carried out by the following trained companies:

- LinMot
- Companies qualified by LinMot

However, assembly, disassembly and inspection can also be carried out by the customer. (see chapters 10.2 to 10.4). Please note that improper inspection, assembly or disassembly can lead to premature wear of the wearing parts and/or damage to the gripper module and/or its components and may invalidate the warranty.

Ordering information

Item	Description	Item-No.
MP01_MT01_GM01-23_EX00_AS00	Maintenance GM01-23: Replacement of all wearing parts, cleaning and lubrication	0120-4800

10.2 Inspection



To ensure the best possible trouble-free operation, a preventive inspection is recommended every 6000 hours of operation or after one year.

The following points should be checked when inspecting the actuators:

- Visual inspection of all wearing parts (replace if necessary)
- Preventive replacement of seals and wipers
- Cleaning of mechanical moving parts
- Replacement and maintenance of ball / plain bearings if necessary

10.3 Troubleshooting

The following points must be checked during the troubleshooting:

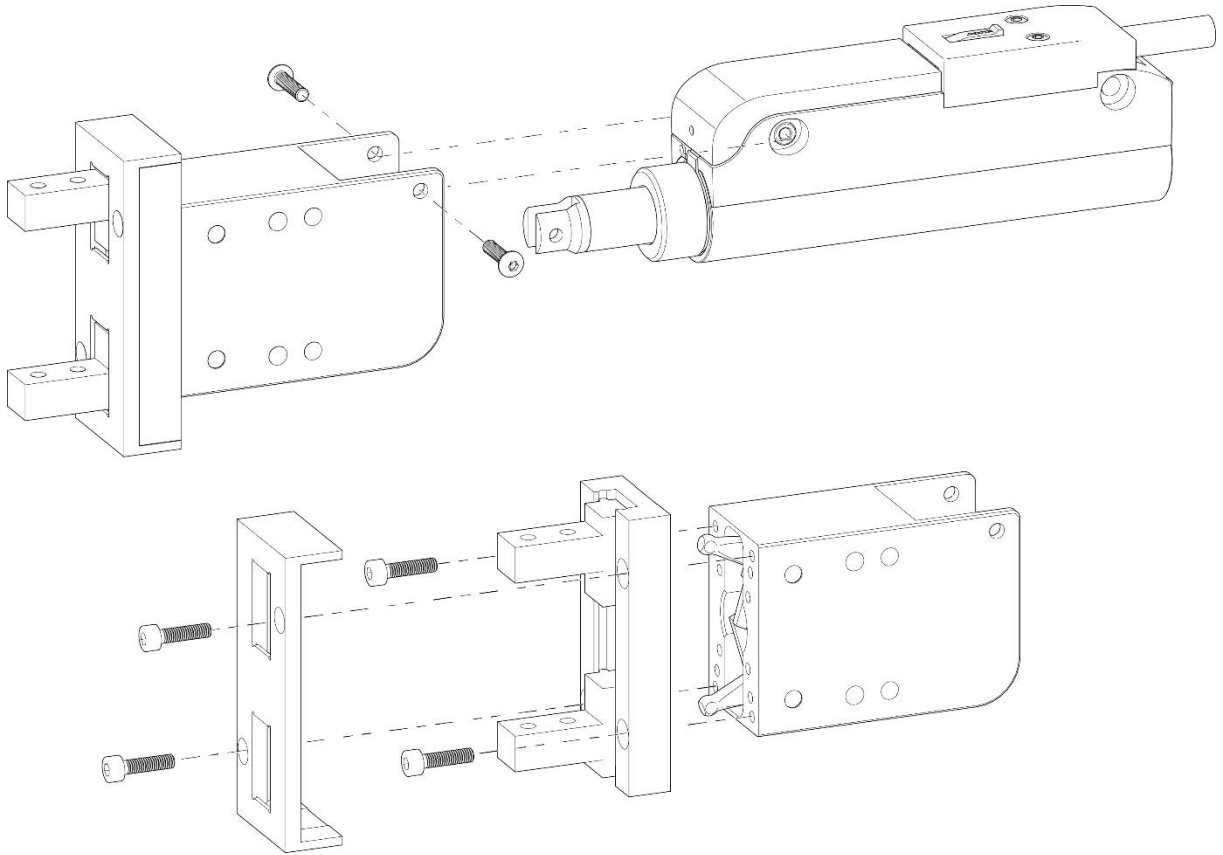
Problem	Solution
Do the gripper fingers have too much or too little play?	Yes -> Check the screw connections as shown.
	
Has the slider of the linear motor been relubricated?	No -> Remove the motor from the gripping unit, dismantle the slider, clean and lubricate it.
Can the guide unit be moved smoothly?	No -> Remove the gripping unit from the motor, check and gently align.



The nuts fastening the trailing chain to the gripper's housing cover must be additionally secured (e.g. with Loctite). If they are not secured in this way, the nuts can come loose and fall into the motor.

10.4 Cleaning and lubrication

10.4.1 Cleaning and lubrication of the linear motor

1. Loosen the connecting element and carefully pull the slider out of the stator. **Caution:** Large magnetic attraction forces (see warning on p. 5). If necessary, cover nearby iron structures with non-magnetic material (e.g. wood).
2. Clean the slider and stator with soft disposable paper, ideally with the aid of LU06 cleaning spray (alternatively methylated spirits or alcohol).
3. Carefully push the slider into the stator.
4. Check the friction over the entire stroke and remove excess grease and dirt when moving the slider.



Caution! Avoid over-greasing! Over-greasing can lead to gumming of the grease, especially at higher operating temperatures. Remove excess grease while moving the slider.

10.4.2 Cleaning and lubrication of the gripping unit

Lubrication of the gripping unit is optional, but can have a positive effect on the sensitivity of the gripper. This is particularly the case if product detection is to be based on current consumption, as the motor current is influenced by the force of movement, dry friction, sliding friction and external forces. A light film of grease will reduce the friction in the plain bearings, which in turn will make the frictional connection more sensitive.



When operating with the recommended grease SKF LGFP 2/1, it should be made aware that the relubrication intervals are strongly dependent on the operating and ambient conditions. In addition to the drive loads in the form of stroke kilometres, speeds and surface pressure, the ambient conditions, such as temperature, draught, humidity and general contamination, also play a decisive role. It is therefore advisable to inspect the specific application regularly and to determine the relubrication intervals from this. The inspection intervals can be extended in stages.

1. Remove the old grease on the guide rods ideally with the help of LU06 cleaning spray (alternatively e.g. petroleum ether) with a soft cleaning cloth or paper towel.
2. Move the moving part of the gripping unit back and forth several times so that the bearings are also degreased. **Note:** It is generally not necessary to dismantle the gripper.
3. Grease the gripping mechanism carefully and completely with SKF LGFP 2/1 grease. Move the moving part of the gripper back and forth. Remove any grease that has been wiped off. There should only be a thin film of grease on the guide rods.

Ordering information

Item	Description	Item-No.
LU06-250	Klüberfood NH1 4-002 Spray* (250 ml)	0150-2394
LU04-50	Lubricant for linear motors** (50 g)	On request
LU04-1000	Lubricant for linear motors** (1000 g)	On request
* LinMot Spray LU06 is identical with KLÜBERFOOD NH1 4-002 (Food grade UH1 approval).		
** LinMot Grease LU04 is identical KLÜBERSYNTH UH1 14-31 (Food grade UH1 approval).		

11 Storage and Transport

- The storage area must be dry, dust-free, frost-free and vibration-free.
- The relative air humidity should be less than 60 %.
- Prescribed storage temperature: -15 °C...70 °C
- The motor must be protected against extreme weather conditions.
- The air in the storage area must not contain any harmful gases.

12 Dimensions & Weights

12.1 Gripper module GM50-23SX80F-XP-K_35-18(_MS03)

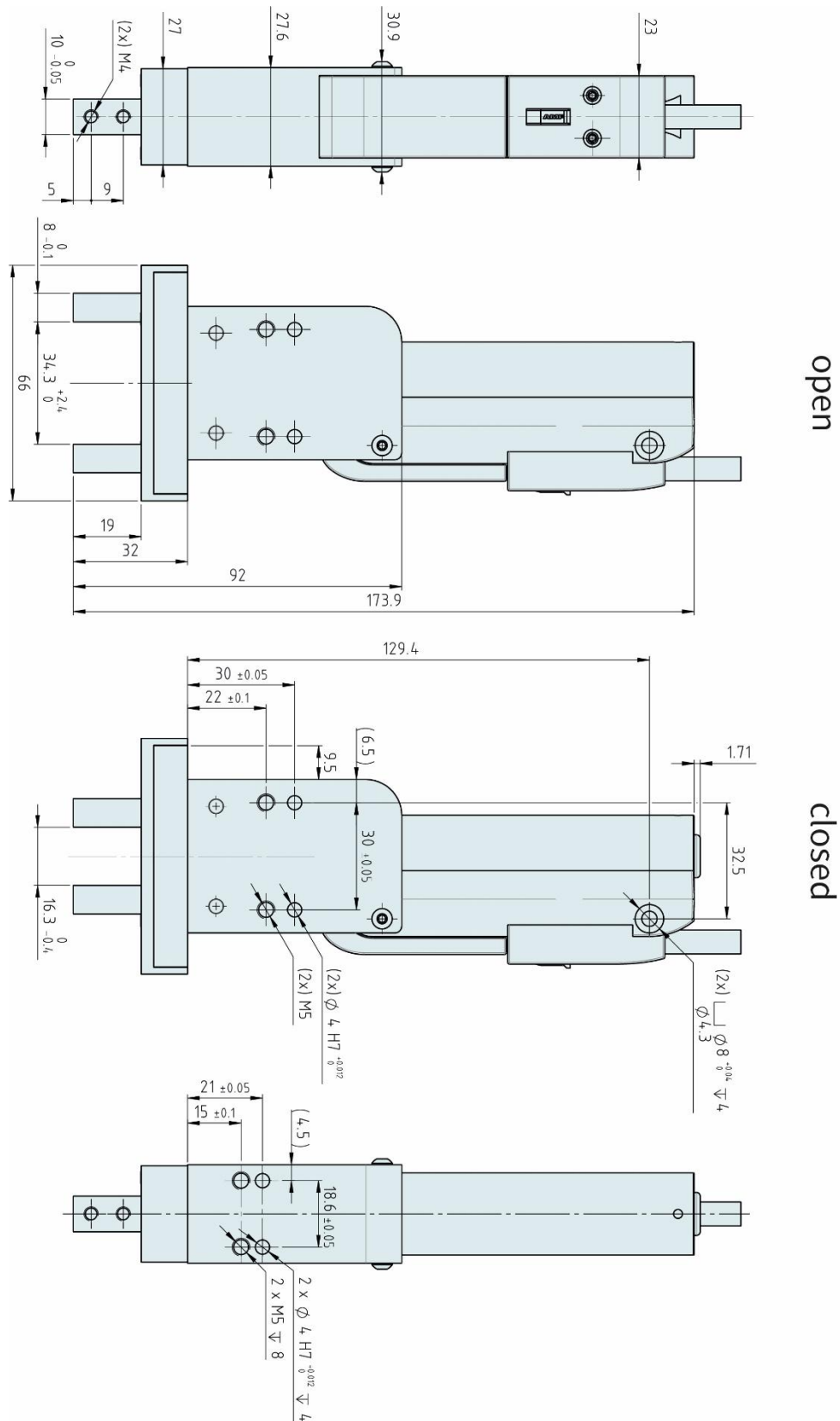

12.2 Gripper module GM50-23SX160H-XP-K_35-18(_MS03)

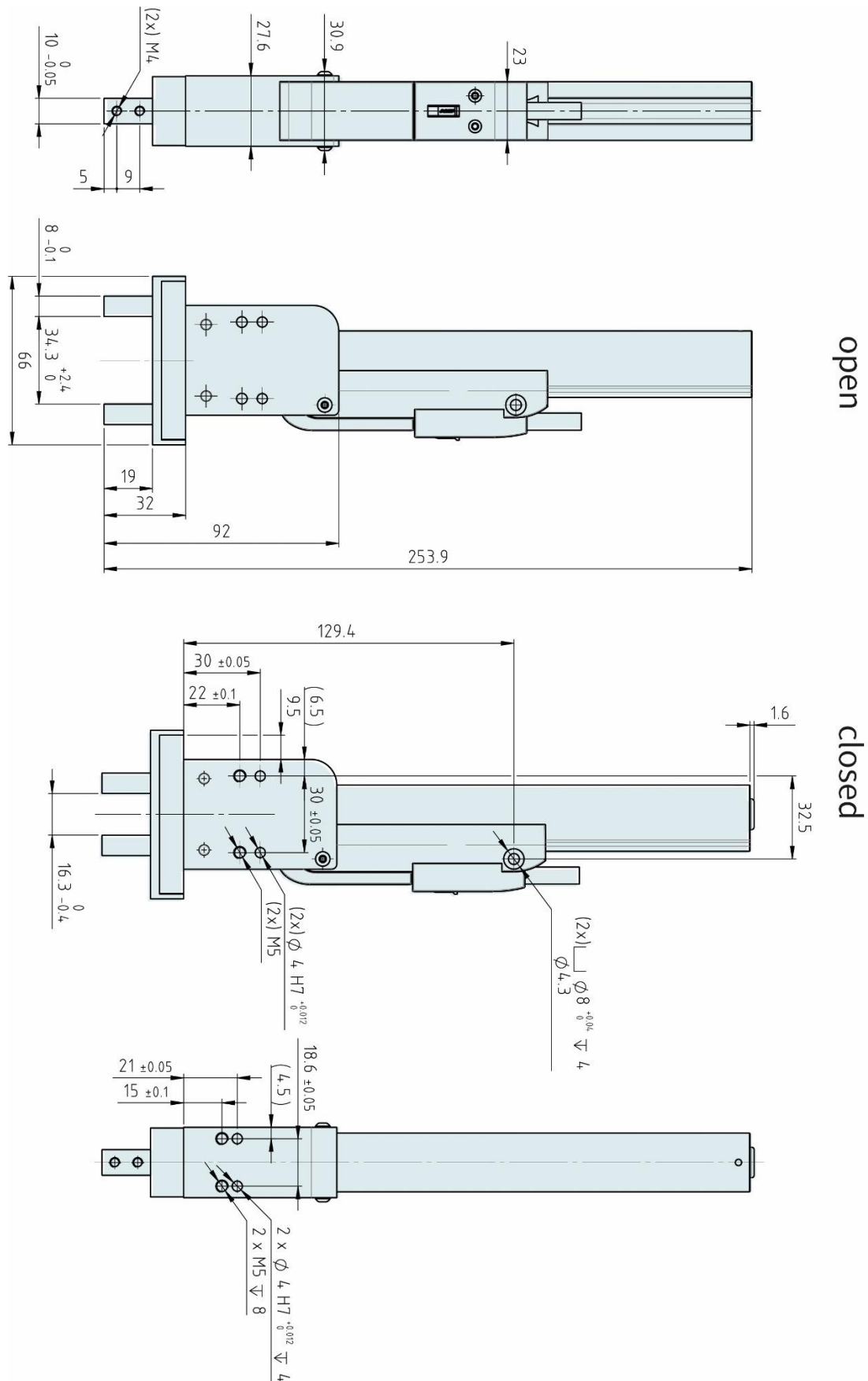

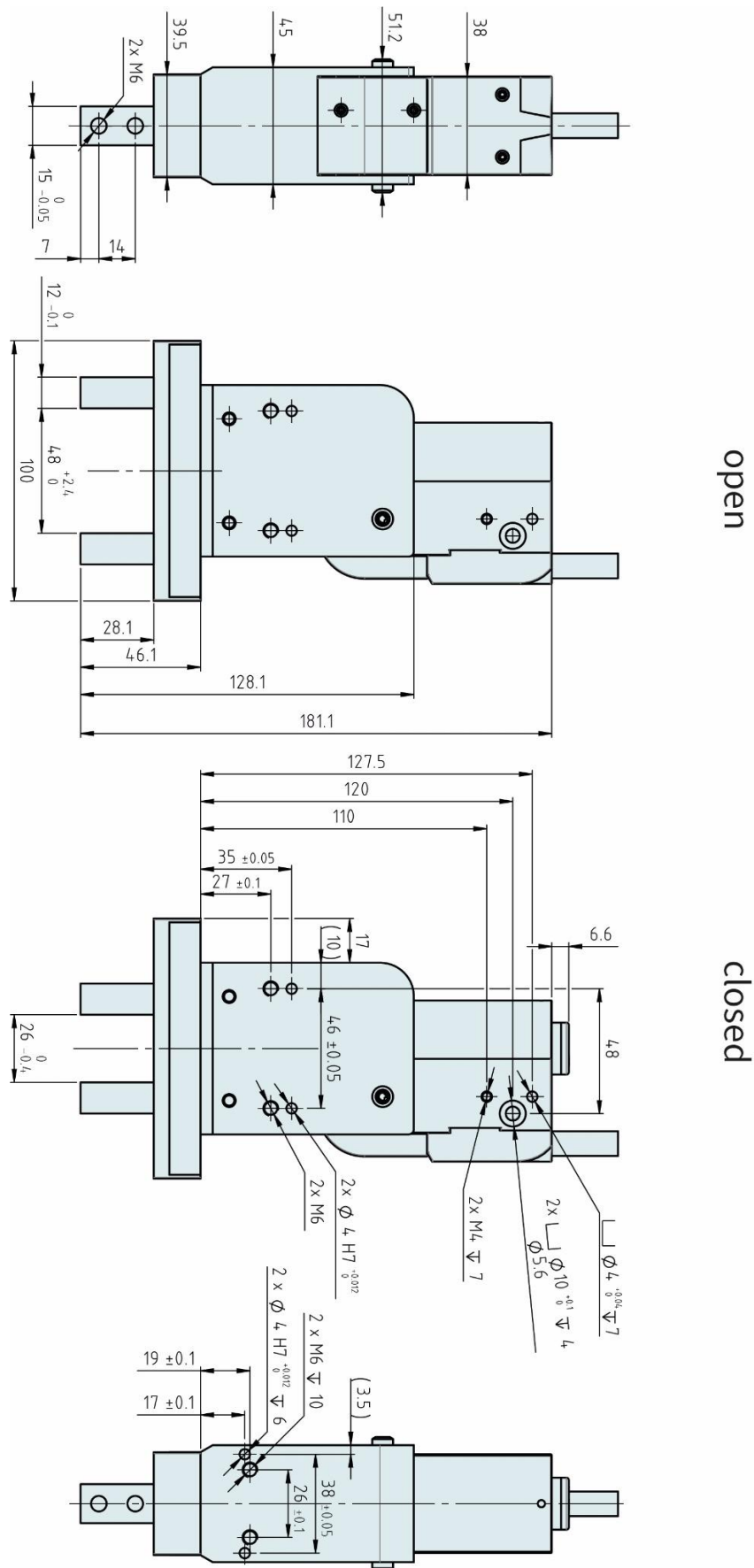

12.3 Gripper module GM50-37SX60-XP-N_48-22(_MS03)

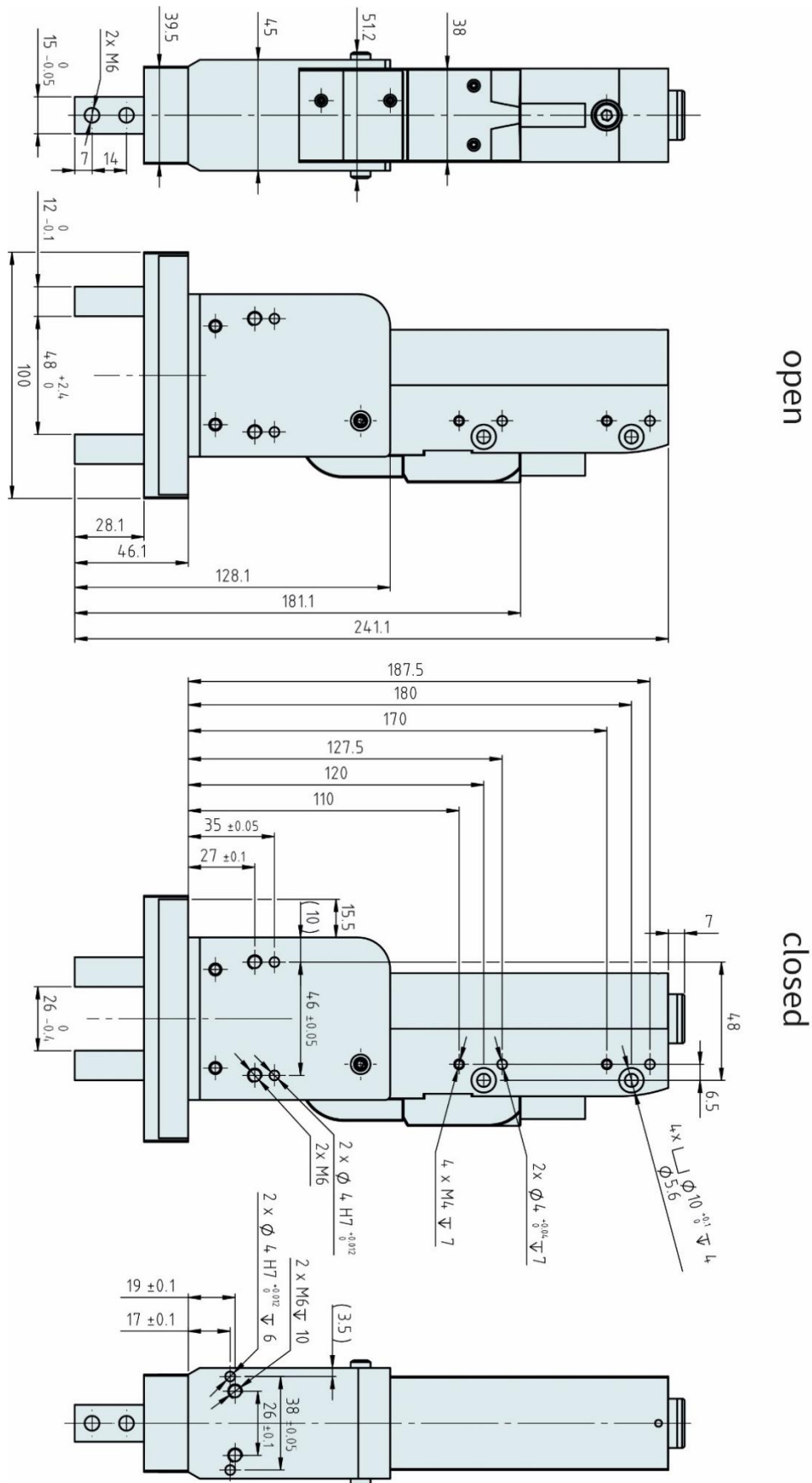

12.4 Gripper module GM50-37SX120-XP-N_48-22(_MS03)



13 International Certificates

<p>Europe</p> 	<p>See chapter “EU Declaration of Conformity CE-Marking”</p>
<p>UK</p> 	<p>See chapter “UK Declaration of Conformity UKCA-Marking”</p>
<p>IECEE CB SCHEME</p>	<p>Ref. Certif. Nr. CH-8521</p>
<p>USA / Canada</p> 	<p>Filenummer E354430 Refers to cURus marked motors</p>



Ref. Certif. No.

CH-8521

IEC SYSTEM FOR MUTUAL RECOGNITION OF TEST CERTIFICATES FOR ELECTRICAL EQUIPMENT (IECEE) CB SCHEME

CB TEST CERTIFICATE

Product	Linear motor	
Name and address of the applicant	NTI AG	Bodenackerstrasse 2 SWITZERLAND 8957 Spreitenbach
Name and address of the manufacturer	NTI AG	Bodenackerstrasse 2 SWITZERLAND 8957 Spreitenbach
Name and address of the factory	NTI AG	Bodenackerstrasse 2 SWITZERLAND 8957 Spreitenbach
<i>Note: When more than one factory, please report on page 2</i>	<input type="checkbox"/> Additional Information on page 2	
Ratings and principal characteristics	supplied via servo drive, see TR 17-EL-0006.E02 for details	
Trade mark (if any)	LinMot	
Customers's Testing Facility (CTF) Stage used	---	
Model / Type Ref.	PR series PS series P04 series P05 series	
Additional information (if necessary may also be reported on page 2)	---	
A sample of product was tested and found to be in conformity with IEC	<input type="checkbox"/> Additional Information on page 2	
National differences	IEC 61000-6-2:2016 IEC 61000-6-4:2006, IEC 61000-6-4:2006/AMD1:2010 IEC 61000-6-7:2014 EU Group Differences; EU Special National Conditions; EU A-Deviations	
As shown in the Test Report Ref. No. which forms part of this Certificate	17-EL-0006.E01 + .E02 + .Z01	



This CB Test Certificate is issued by the National Certification Body

Electrosuisse
Luppenstrasse 1
8320 Fehraltorf
SWITZERLAND

Signed by: Martin Plüss
Date: 2017-03-13



CERTIFICATE OF COMPLIANCE

Certificate Number UL-US-2138367-0
Report Reference E354430-20210817
Date 23-Aug-2021

Issued to: NTI AG
Bodenaeckerstr 2 SPREITENBACH
Switzerland 8957

This is to certify that representative samples of NDMM2 - Incomplete Rotating Machines and Rotating Machine Parts - Component
See Addendum Page for Product Designation(s).

Have been investigated by UL in accordance with the component requirements in the Standard(s) indicated on this Certificate. UL Recognized components are incomplete in certain constructional features or restricted in performance capabilities and are intended for installation in complete equipment submitted for investigation to UL LLC.

Standard(s) for Safety: UL 1004-1, 2nd Ed., Issue Date: 2012-09-19, Revision Date: 2020-11-05

Additional Information: See the UL Online Certifications Directory at <https://iq.ulprospector.com> for additional information

This *Certificate of Compliance* does not provide authorization to apply the UL Recognized Component Mark. Only the UL Follow-Up Services Procedure provides authorization to apply the UL Mark.

Only those products bearing the UL Recognized Component Mark should be considered as being UL Certified and covered under UL's Follow-Up Services.

Look for the UL Recognized Component Mark on the product.

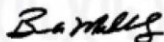

Bruce Mahrenholz, Director North American Certification Program

UL LLC

Any information and documentation involving UL Mark services are provided on behalf of UL LLC (UL) or any authorized licensee of UL. For questions, please contact a local UL Customer Service Representative at <http://ul.com/aboutul/locations/>



14 EU Declaration of Conformity CE-Marking

NTI AG / LinMot ®
Bodenaeckerstrasse 2
8957 Spreitenbach

Switzerland

Tel.: +41 (0)56 419 91 91
Fax: +41 (0)56 419 91 92

declares under sole responsibility the compliance of the products:

- Gripper modules of the **GM50** series
with the EMC Directive 2014/30/EU.

Applied harmonized standards:

- **EN 61000-6-2: 2005 (Immunity for industrial environments)**
- **EN 61000-6-4: 2007 + A1: 2011 (Emission for industrial environments)**

According to the EMC directive, the listed devices are not independently operable products.

Compliance of the directive requires the correct installation of the product, the observance of specific installation guides and product documentation. This was tested on specific system configurations.

The safety instructions of the manuals are to be considered.

The product must be mounted and used in strict accordance with the installation instructions contained within the installation guide, a copy of which may be obtained from NTI AG.

Company: NTI AG
Spreitenbach, 17/06/2026



Dr.-Ing. Ronald Rohner
CEO NTI AG

15 UK Declaration of Conformity UKCA-Marking

NTI AG / LinMot ®
Bodenaeckerstrasse 2
8957 Spreitenbach

Switzerland

Tel.: +41 (0)56 419 91 91
Fax: +41 (0)56 419 91 92

declares under sole responsibility the compliance of the products:

- Gripper modules of the **GM50** series
with the EMC Regulation S.I. 2016 No. 1091.

Applied designated standards:

- **EN 61000-6-2: 2005 (Immunity for industrial environments)**
- **EN 61000-6-4: 2007 + A1: 2011 (Emission for industrial environments)**

According to the EMC regulation, the listed devices are not independently operable products.

Compliance of the regulation requires the correct installation of the product, the observance of specific installation guides and product documentation. This was tested on specific system configurations.

The safety instructions of the manuals are to be considered.

The product must be mounted and used in strict accordance with the installation instructions contained within the installation guide, a copy of which may be obtained from NTI AG.

Company: NTI AG
Spreitenbach, 17/06/2026



Dr.-Ing. Ronald Rohner
CEO NTI AG

ALL LINEAR MOTION FROM A SINGLE SOURCE

Europe / Asia Headquarters

NTI AG - LinMot & MagSpring

Bodenaeckerstrasse 2
CH-8957 Spreitenbach
Switzerland

Sales / Administration: +41 56 419 91 91
office@linmot.com

Tech. Support: +41 56 544 71 00
support@linmot.com

Web: <https://www.linmot.com/>

Visit <https://linmot.com/contact/> to find a distributor near you.

North / South America Headquarters

LinMot USA Inc.

N1922 State Road 120, Unit 1
Lake Geneva, WI 53147
USA

Sales / Administration: 262.743.2555
usasales@linmot.com

Tech. Support: 262.743.2555
usasupport@linmot.com

Web: <https://www.linmot.com/>