

# Installation Guide Gripper Modules

ENG

## GM01-23



## Content

<b>1</b>	<b>General Information</b>	<b>4</b>
1.1	Introduction	4
1.2	Explanation of Symbols	4
1.3	Qualified Personnel	4
1.4	Liability	4
1.5	Copyright	4
<b>2</b>	<b>Safety Instructions</b>	<b>5</b>
<b>3</b>	<b>Intended Use</b>	<b>7</b>
3.1	Designation code	7
3.2	Variations and identification	7
3.2.1	Identification by type plate	7
3.3	Product description Gripper Module GM01	8
3.4	Operating conditions	8
3.5	Guiding accuracy	9
3.6	Technical data gripper modules	10
<b>4</b>	<b>Installation Instructions</b>	<b>11</b>
4.1	Mounting the gripper	11
4.1.1	Mounting direction	11
4.2	Mounting the clamping device	13
4.3	Mounting the gripper module	14
4.4	Mounting the gripper finger	14
<b>5</b>	<b>Clamping Jaw Principle</b>	<b>15</b>
5.1	Round products with a sensitive surface	16
5.2	Line up several products at the same time according to the shovel-broom principle	16
5.3	Large and/or flat products with adhesive surface	17
<b>6</b>	<b>Material specifications</b>	<b>18</b>
<b>7</b>	<b>Electrical Connection</b>	<b>19</b>
7.1	Motor cable	19
7.1.1	Technical data	19
7.2	Motor connector	19
7.2.1	Pin assignment R-connector	20
7.3	Additional protection for the plug connection	20
<b>8</b>	<b>Start-up</b>	<b>21</b>
8.1	Setting the parameters	21
8.2	Plug-and-Play	21
8.2.1	Application-specific parameters	21
8.2.2	Referencing the linear motor	21
8.2.3	Current/force limitation of the linear motor	21
<b>9</b>	<b>Accessories</b>	<b>23</b>
9.1	Motor cable	23
9.2	Extension cable	24
9.2.1	Extension connector with IP67S protection	24

9.3	Wiper.....	24
<b>10</b>	<b>Maintenance .....</b>	<b>25</b>
10.1	Maintenance cycles of the gripper module .....	25
10.2	Inspection.....	25
10.3	Troubleshooting .....	26
10.4	Cleaning and lubrication .....	27
10.4.1	Cleaning and lubrication of the linear motor .....	27
10.4.2	Cleaning and lubrication of the guide rods .....	27
<b>11</b>	<b>Storage, Transport, Installation Altitude .....</b>	<b>28</b>
<b>12</b>	<b>Dimensions &amp; Weights.....</b>	<b>29</b>
12.1	Gripper module GM01-23x80F-HP-R150-90-SSCP .....	29
12.2	Gripper module GM01-23x160H-HP-R150-170-SSCP .....	30
<b>13</b>	<b>International Certificates.....</b>	<b>31</b>
<b>14</b>	<b>EU Declaration of Conformity CE-Marking .....</b>	<b>34</b>
<b>15</b>	<b>UK Declaration of Conformity UKCA-Marking.....</b>	<b>35</b>

# 1 General Information

## 1.1 Introduction

This manual includes instructions for the assembly, installation, maintenance, transport, and storage of linear guides / linear modules. The document is intended for electricians, mechanics, service technicians, and warehouse staff.

Read this manual before using the product and observe the general safety instructions and those in the relevant section at all times.

Keep these operating instructions in an accessible place and make them available to the personnel assigned.

## 1.2 Explanation of Symbols



Triangular warning signs warn of danger.



Round command symbols tell what to do.

## 1.3 Qualified Personnel

All work such as installation, commissioning, operation and service of the product may only be carried out by qualified personnel.

The personnel must have the necessary qualifications for the corresponding activity and be familiar with the installation, commissioning, operation and service of the product. The manual and in particular the safety instructions must be carefully read, understood and observed.

## 1.4 Liability

NTI AG (as manufacturer of LinMot and MagSpring products) excludes all liability for damages and expenses caused by incorrect use of the products. This also applies to false applications, which are caused by NTI AG's own data and notes, for example in the course of sales, support or application activities. It is the responsibility of the user to check the data and information provided by NTI AG for correct applicability in terms of safety. In addition, the entire responsibility for safety-related product functionality lies exclusively with the user. Product warranties are void if products are used with stators, sliders, servo drives or cables not manufactured by NTI AG unless such use was specifically approved by NTI AG.

NTI AG's warranty is limited to repair or replacement as stated in our standard warranty policy as described in our "terms and conditions" previously supplied to the purchaser of our equipment (please request copy of same if not otherwise available). Further reference is made to our general terms and conditions.

## 1.5 Copyright

This work is protected by copyright.

Under the copyright laws, this publication may not be reproduced or transmitted in any form, electronic or mechanical, including photocopying, recording, microfilm, storing in an information retrieval system, not even for training purposes, or translating, in whole or in part, without the prior written consent of NTI AG.

LinMot® and MagSpring® are registered trademarks of NTI AG.

## 2 Safety Instructions



### Contusions

Sliders contain neodymium magnets and have a strong attractive force. Careless handling could cause fingers or skin to become pinched between two sliders. This may lead to contusions, bruises, and bone fractures. When handling sliders, wear thick protective gloves and keep a minimum distance between sliders. Refer to the "Minimum distance from slider" section for minimum distance.

To reduce the risk of injury, never more than one slider should be held or transported by the same person without packaging.



### Pacemaker / Implanted Heart Defibrillator

Sliders could affect the functioning of pacemakers and implanted heart defibrillators. For the duration of a strong approach to a magnetic field, these devices switch into test mode and will not function properly.

- If you wear one of those devices keep the following minimum distances between the pacemaker / defibrillator and slider:
  - Min. 250 mm (10") for slider Ø 27 mm and 28 mm (PL01-27 / 28 / PL10-28)
  - Min. 150 mm (6") for slider Ø 19 mm and 20 mm (PL01-19 / 20)
  - Min. 100 mm (4") for slider Ø 12 mm (PL01-12)
- Inform others who wear these devices to comply with these minimum distances!



### Caution - Risk of Electric Shock !

Before working, make sure that there are no high voltages.



### Fast-moving Machine Parts

The sliders of LinMot linear motors are fast-moving machine parts. All necessary precautions must be taken to prevent persons approaching the moving elements during operation (provide covers, guards, etc.).



### Automatic Restart

The motors can start automatically under certain circumstances! If necessary, a corresponding warning symbol must be provided and protection against entering the hazardous area or a suitable safe electronic disconnection must be provided!



### Risk of Injury due to a Defect or Fault

For areas where a defect or fault can result in substantial property damage or even serious personal injury, additional external precautions must be taken or devices must be installed to ensure safe operation even if a defect or fault occurs (eg. suitable safe electronic disconnection, mechanical interlocks, barriers, etc.).



### Magnetic Field

Magnets integrated in the sliders produce a strong magnetic field. They could damage TVs, laptops, computer hard drives, credit and ATM cards, data storage media, mechanical watches, hearing aids, and speakers.

- Keep magnets away from devices and objects that could be damaged by strong magnetic fields.
- For the above mentioned objects, keep a minimum distance as described in the "Pacemaker / implanted defibrillator" section.
- For non-anti-magnetic watches, keep the double minimum distance.

**Combustibility**

When machining magnets, the drilling dust could easily ignite. Machining the sliders and the magnets they contain is not permitted.

**Burn Hazard**

During operation the slider can become hotter than 100 °C, which can cause burns if touched. All necessary precautions (e.g. covers, casing, etc.) must be taken to prevent contact with persons in the vicinity of the slider during operation.

**Grounding**

All metal parts that are exposed to contact during any user operation or servicing and likely to become energized shall be reliably connected to the means for grounding.

**Mechanical Handling**

Neodymium magnets are brittle and heat-sensitive. Machining the sliders and the magnets they contain is not permitted.

- Colliding magnets could crack. Sharp splinters could be catapulted for several meters and cause eye injury.
- By machining the sliders, heat would result which demagnetizes the magnets.

**2S Stators**

Series 2S stators correspond mechanically to the respective standard stators and are to be handled in exactly the same way in terms of assembly. For special features, please refer to the safety manual (Item-No. 0185-1174).

**Slider**

Linear motor sliders consist of a high-precision, thin-walled stainless steel tube in which the neodymium magnets are housed. The LinMot sliders should be handled with care. Avoid contact with other sliders or iron parts as this can damage the magnets and the slider surface. Do not grip the sliders with pliers, as this can also damage the surface. Do not use sliders which are already damaged on the surface (scratches, deformation, etc.). This can cause further damage to the stator.

**Effects on People**

According to the current level of knowledge, magnetic fields of permanent magnets do not have a measurable positive or negative effect on people. It is unlikely that permanent magnets constitute a health risk, but it cannot be ruled out entirely.

- For your own safety, avoid constant contact with magnets.
- Store large magnets at least one meter away from your body.

**Temperature Resistance**

Keep slider away from unshielded flame or heat. Temperature above 120°C will cause demagnetization.

### 3 Intended Use

#### 3.1 Designation code

GM01-23x80F-HP-R150-90-SSCP



#### 3.2 Variations and identification

##### 3.2.1 Identification by type plate

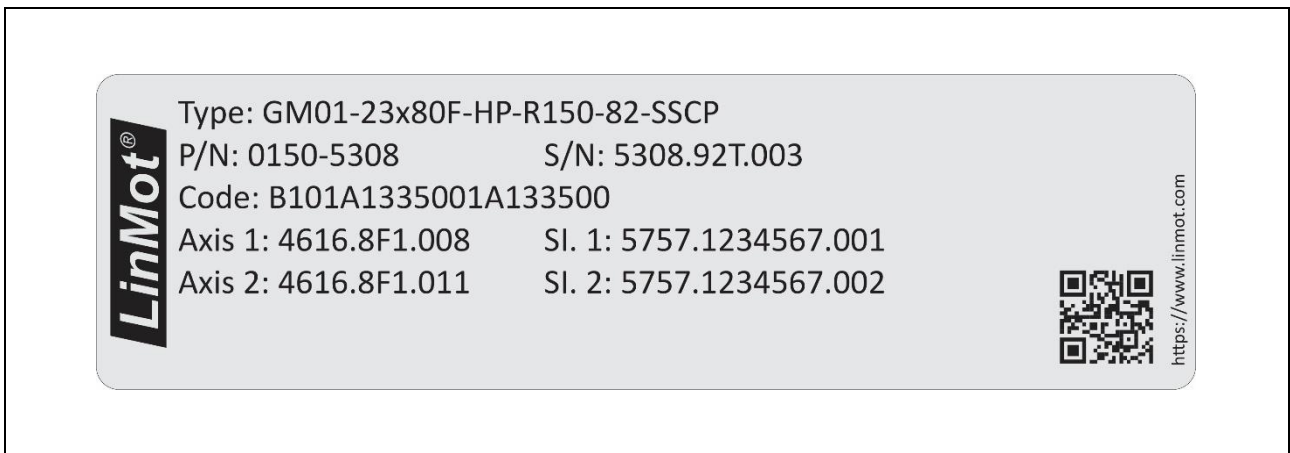

Designation type plate	Meaning
Type	Gripper module type
P/N	Item number gripper module
S/N	Serial number gripper module
Code	Code for internal use only
Axis 1	Serial number stator 1
Axis 2	Serial number stator 2
Sl. 1	Serial number slider 1
Sl. 2	Serial number slider 2

### 3.3 Product description Gripper Module GM01

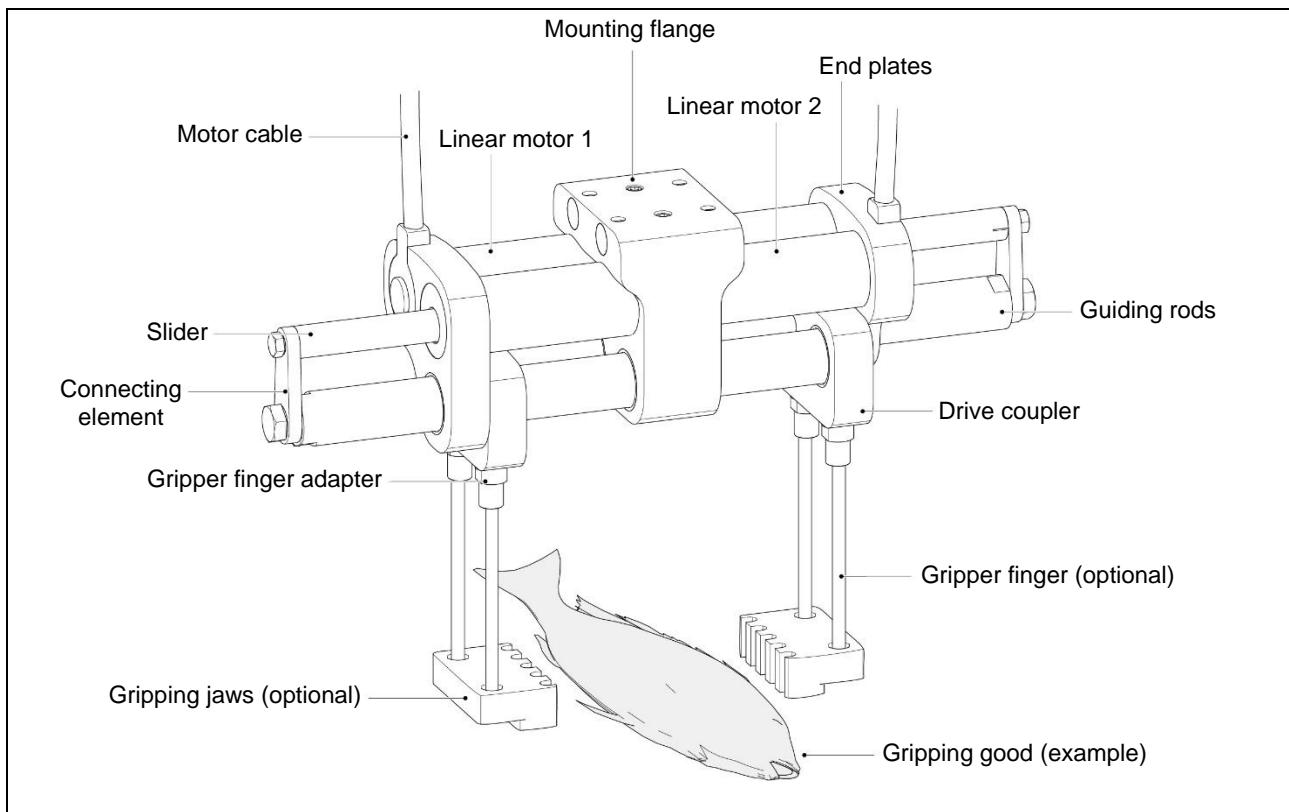

The electric gripper is used for precise clamping and moving of products in demanding environments. Thanks to the high flexibility of the settings, dry, moist, solid or soft products can be gripped and transported gently without leaving any marks or damaging the gripped goods. With its hygienic design and high IP69 protection rating, the gripper is easy to clean and is designed for use in the food and pharmaceutical industries, among others. By detecting the position of the gripper and controlling the clamping force, even uneven products can be gripped reliably. The GM01 intelligent gripper includes a wide range of monitoring options, which are essential for applications with a high degree of automation. This means that incorrect gripping or faulty parts can be detected and sorted out during operation.

### 3.4 Operating conditions



- Ambient temperature limit is -10°C...80°C
- The maximum sensor temperature is 90°C
- The maximum installation altitude is 4.000 m above sea level. From 1.000 m, a reduction of 1 °C per 100 m must be taken into account for air cooling.



### 3.5 Guiding accuracy

The operating principle of bearings is based on a sufficiently large bearing clearance. This is in the order of magnitude of approx. 0.1 mm and can increase accordingly during the service life. This clearance becomes noticeable when the gripper grips a product with a force  $F$ . Both the force  $F$  and the distance  $L$  should be as small as possible to keep the torque  $M$  low. A higher torque  $M$  can lead to an increase in sliding friction and thus to problems with precise positioning of the actuator. (See chapter 10.4 "Cleaning and lubrication").

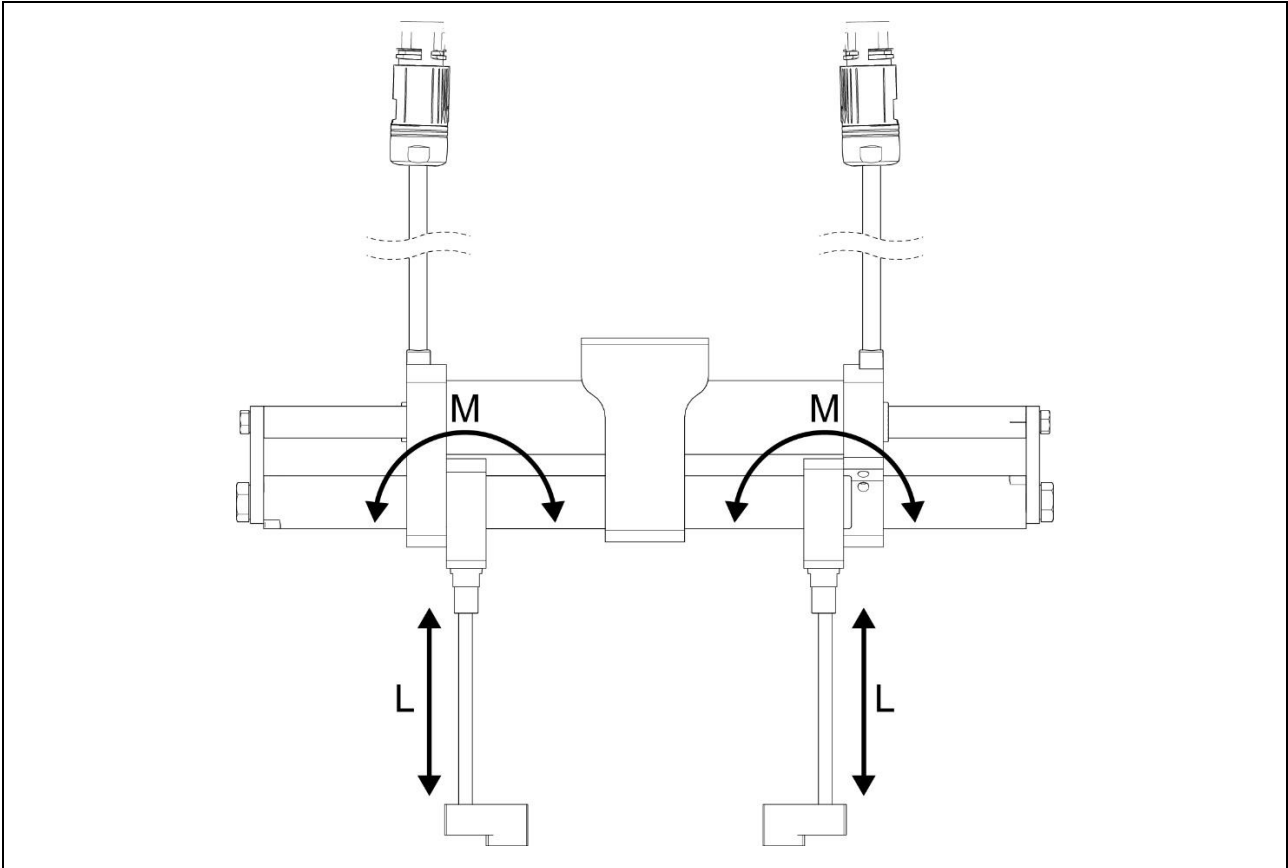

### 3.6 Technical data gripper modules

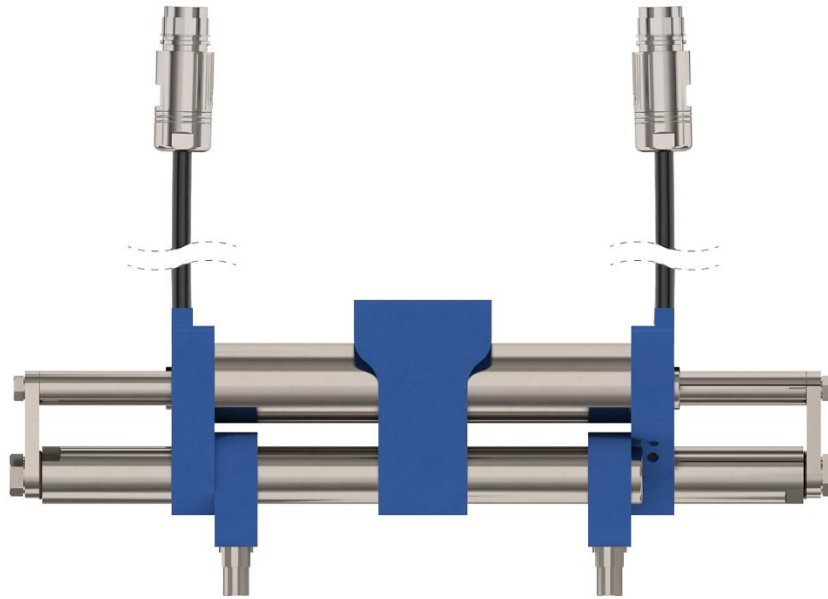

GM01-...	...23x80F...		...23x160H...	
Max. Opening/Closing Stroke Range	≤ 90 mm	(≤ 3.54 in)	≤ 170 mm	(≤ 6.69 in)
Max. Clamping Force @ 48VDC*	67.1 N	(15.08 lbf)	116 N	(26.08 lbf)
Max. Clamping Force @ 72VDC*	67.1 N	(15.08 lbf)	138 N	(31.01 lbf)
Permanent Clamping Force*	12 N	(2.69 lbf)	23.5 N	(5.28 lbf)
Max. Gripper Speed (Close/Open)	3.5 m/s	(137.79 in/s)	3.1 m/s	(122.05 in/s)
Position Resolution	0.002 mm	(0.00008 in)	0.002 mm	(0.00008 in)
Repeatability	±0.05 mm	(±0.002 in)	±0.05 mm	(±0.002 in)
Max. Current per Gripper Arm @ 48VDC	7.4 A <sub>pk</sub>		10 A <sub>pk</sub>	
Max. Current per Gripper Arm @ 72VDC	7.4 A <sub>pk</sub>		10 A <sub>pk</sub>	
Constant Force	8.95 N/A <sub>pk</sub>		12.6 N/A <sub>pk</sub>	
Gripper Width	71 mm	(2.80 in)	71 mm	(2.80 in)
Gripper Length	247 mm	(9.72 in)	407 mm	(16.02 in)
Gripper Height (without / with Gripper Finger)	104 / 165 mm	(4.09 / 6.50 in)	104 / 165 mm	(4.09 / 6.50 in)
Gripper Mass	2695 g	(5.94 lb)	3425 g	(7.55 lb)
Moving Mass (Slider, Guiding Rod, Drive Coupler, Connecting Element)	520 g	(1.15 lb)	680 g	(1.50)
Cable Length	1500 mm	(59.06 in)	1500 mm	(59.06 in)
Coupling Gripping Jaws	M5			
Material (Motor Mount / Gripping Jaws / Mounting Flange)	POM			
Material (Stator / Slider / Guide)	1.4404 316L			
Material (Cable Jacket)	PUR			
IP Protection Class**	IP69			

\*The clamping force can be set via the motor current or the motor force constant.

\*\*Protection class of motor connection IP67S.

## 4 Installation Instructions

### 4.1 Mounting the gripper



Before carrying out any of the following operations, all necessary precautions must be taken to ensure that the equipment is not in operation. Before installing the gripper, ensure that the equipment is voltage-free and that the safety measures in Chapter 2 are followed.

The mounting flange is used to attach the gripper to the customer's equipment. The four M5 stainless steel threaded inserts are fixed into the plastic. See chapter 12 for detailed mounting dimensions. The corresponding CAD files are available in the LinMot eCatalogue <https://shop.linmot.com/>.



The middle threads are used to fix the stators and cannot be used for mounting.

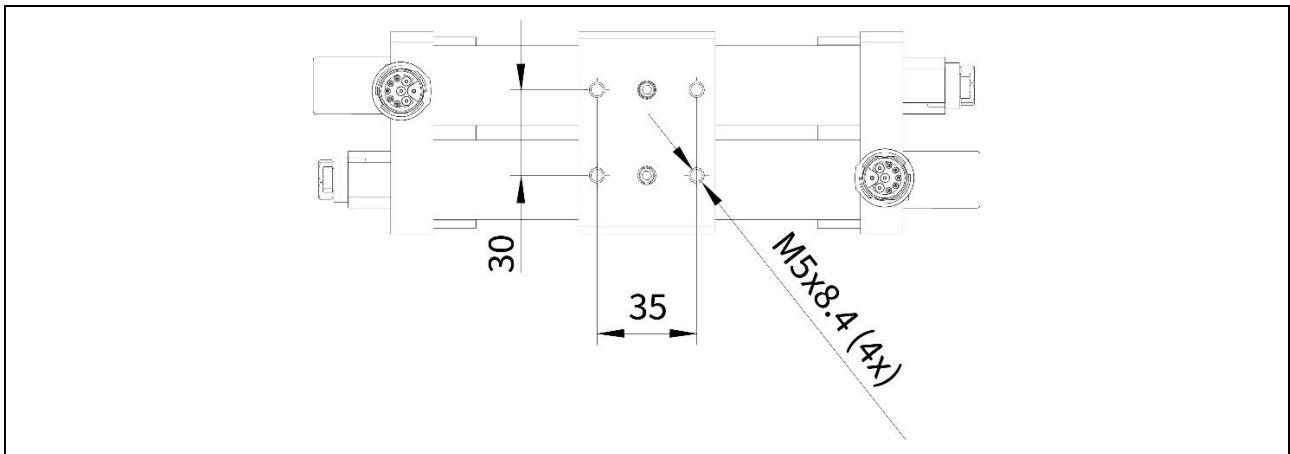

#### 4.1.1 Mounting direction

The gripper can be oriented in any direction via the mounting flange. The corresponding direction must be taken into account when dimensioning.

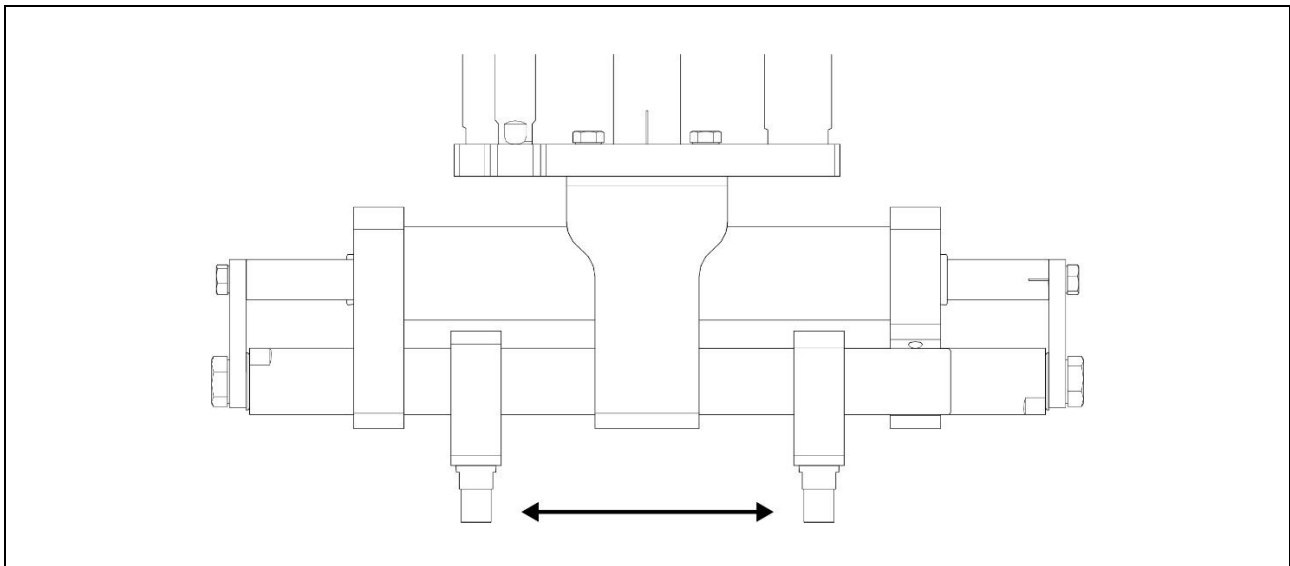

Example 1: horizontal assembly "gripper down". Gripping and depositing, stacking, aligning and centring products.

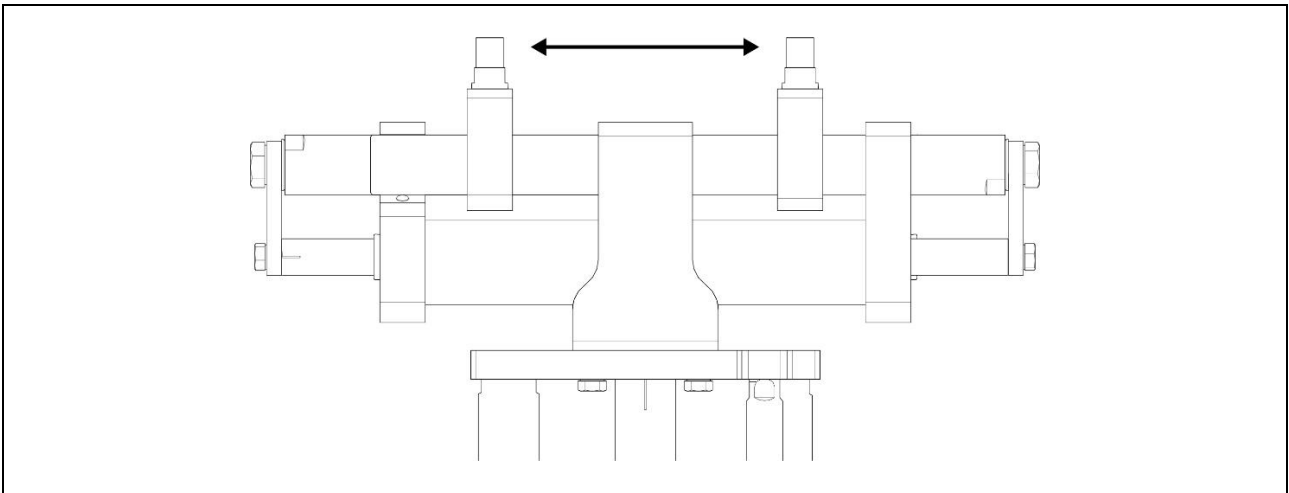

Example 2: horizontal assembly "gripper on top". Gripping and depositing, stacking, aligning and centring products.

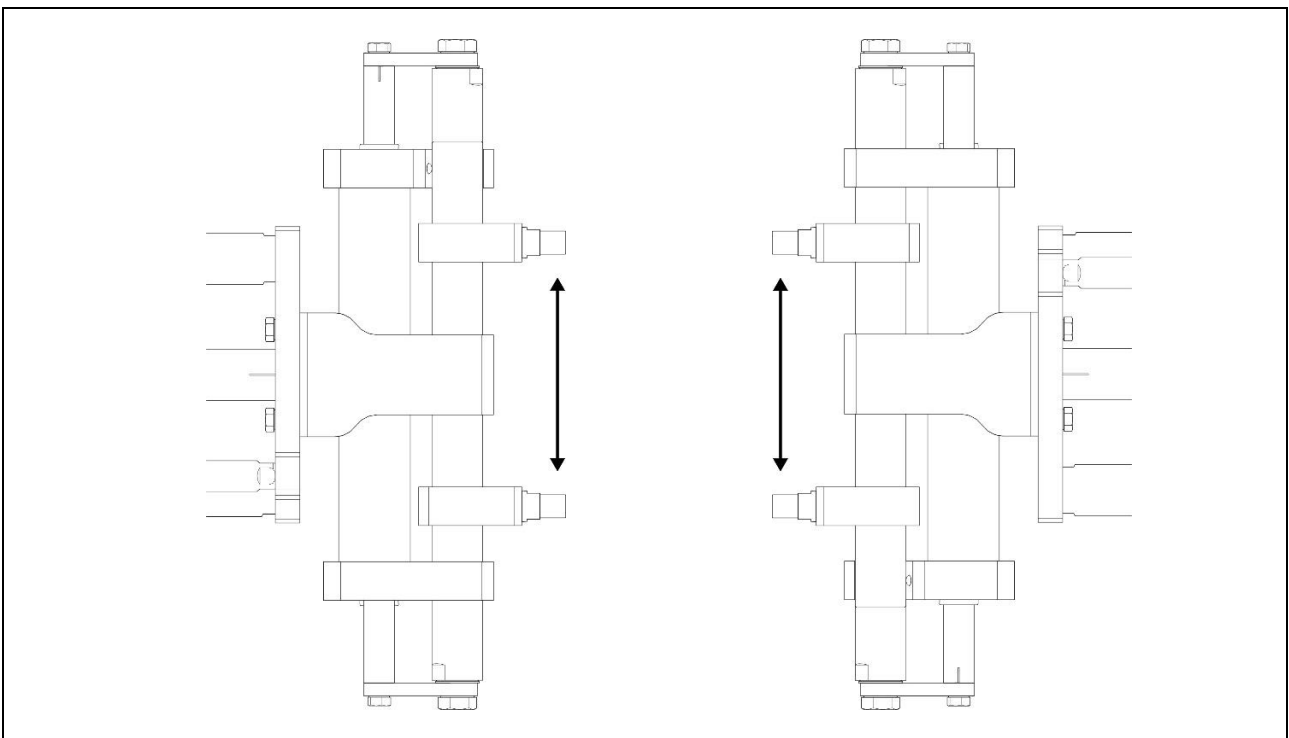

Example 3: vertical mounting. Mounting e.g. on a robot arm.

## 4.2 Mounting the clamping device



Before installing the clamping device (gripper fingers and gripper jaws), all necessary precautions must be taken to prevent the device from operating, e.g. the device must be disconnected from the power supply.

The drive couplers are bolted to one rod and slide on the second, parallel guide rod. A single drive coupler can move half the maximum clamping distance.

M6 set screws or bolts must be used to mount the gripper fingers. Two fixing points are provided for each drive coupler.

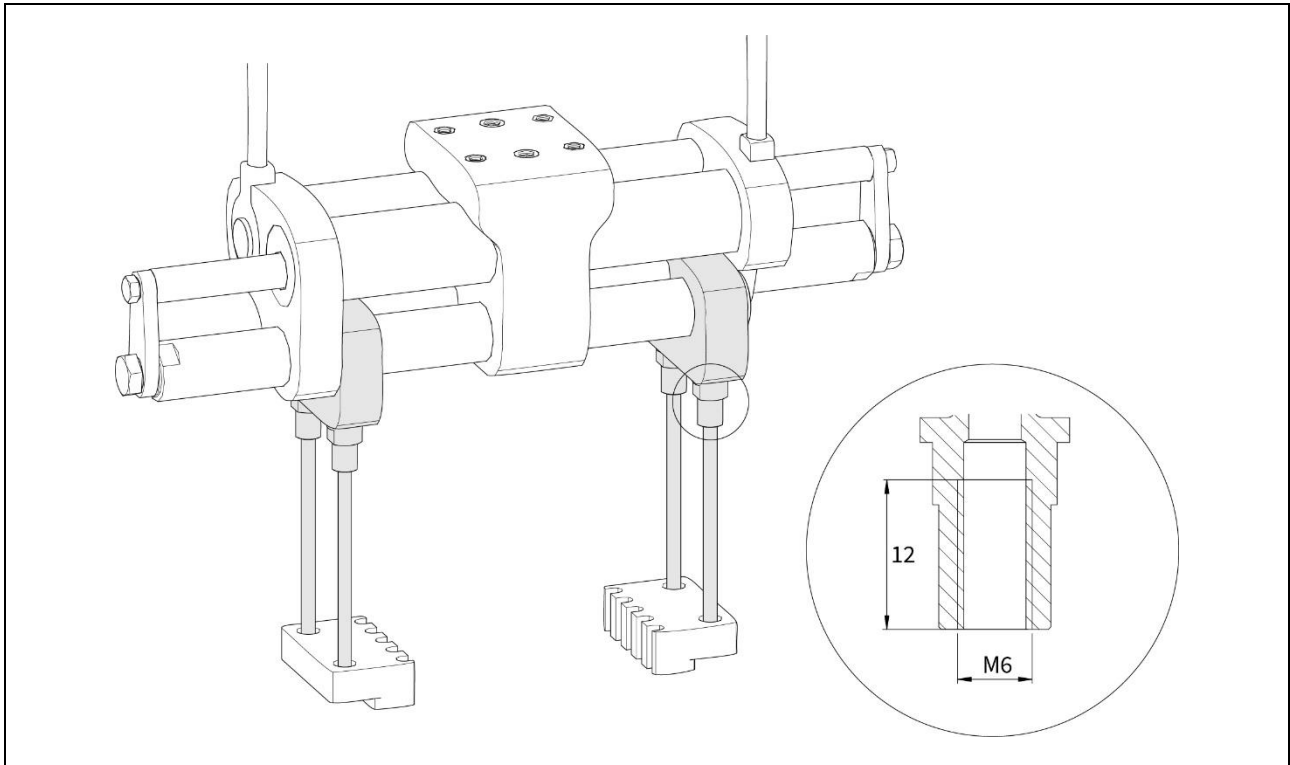

### 4.3 Mounting the gripper module

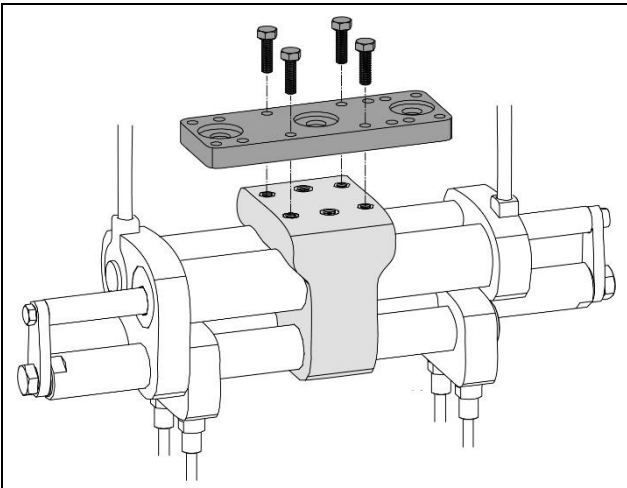

The gripper module is attached to the custom fixture using the mounting flange. The four M5x8.4 stainless steel threaded inserts anchored in the plastic must be used.



Please note that the maximum torque must always be observed. The centre threads are used to fasten the stators and cannot be used for mounting.

### 4.4 Mounting the gripper finger

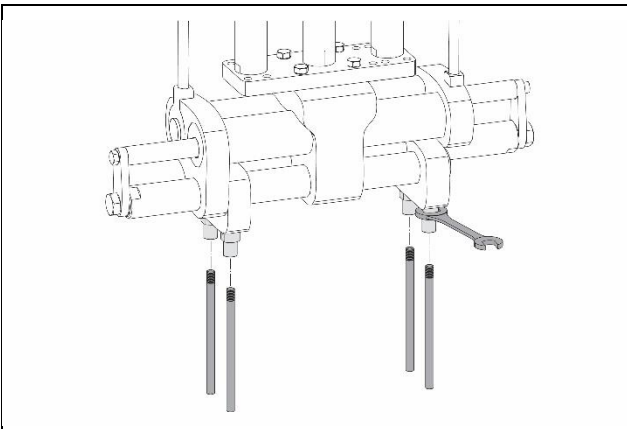

The customised gripper fingers are attached to the drive couplers using the four M6x12 threaded adapters.



When tightening or loosening the gripper fingers, hold the thread adapters firmly with a spanner. Please note that the maximum torque must always be observed.

## 5 Clamping Jaw Principle

Thanks to the dynamic and flexible features of the gripper with LinMot linear motors, any shape of gripper is possible, which can be adapted to the characteristics and shape of the product to be gripped. Despite the customised design, the gripper fingers and jaws can be adjusted in force and position and moved as required.



- Chapter 5.1 shows gripper jaw principles that have already been realised. As the clamping device is designed by the customer, the illustrations of the gripper fingers and gripper jaws in this document may differ from reality and are only intended as inspiration.
- The clamping device consisting of gripping fingers and gripping jaws is not included.

When using the gripper, it must be taken into account that the two drive couplers cannot be fully closed against each other. In order to be able to close the clamping device completely, this must be taken into account when designing the gripper jaws.

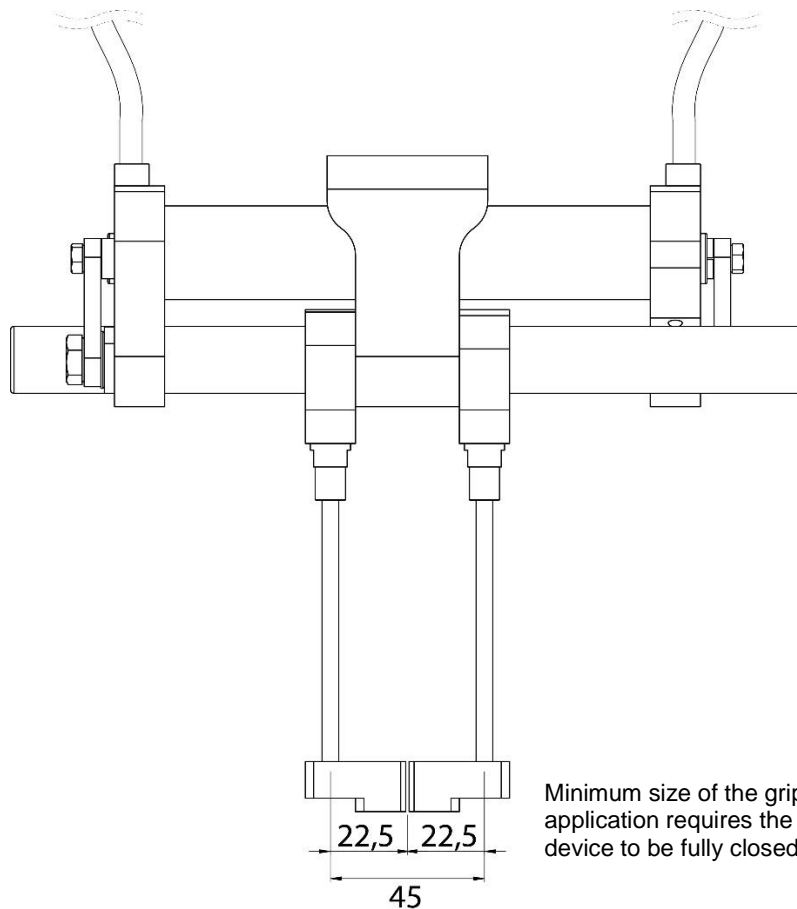

## 5.1 Round products with a sensitive surface

The gripper closes until the product is enclosed or, if necessary, lightly touched. Regardless of the size, it is possible to check whether a product has been gripped correctly. To prevent slipping, the contact pressure can be increased (depending on the transport dynamics). Setting down can be done by slowly or quickly opening one or both clamping jaws. By measuring, checking and storing information such as position, force and temperature, process steps are 100% verifiable and traceable.

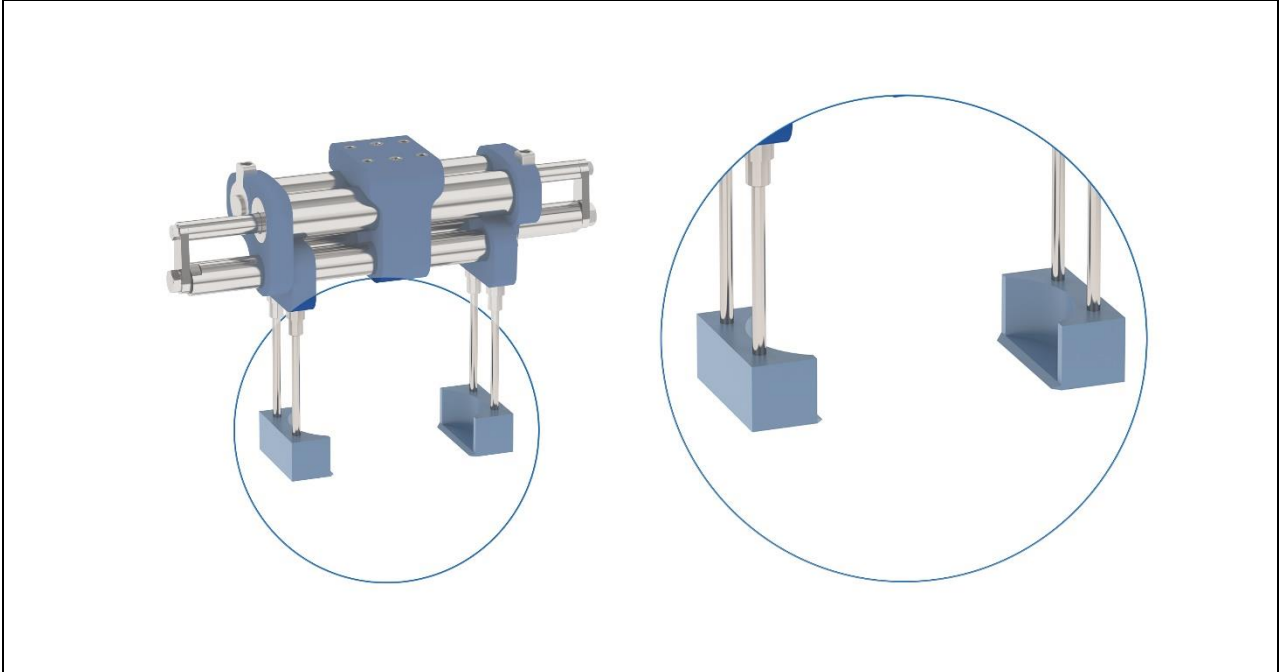

## 5.2 Line up several products at the same time according to the shovel-broom principle

The clamping jaw (right) pushes the product onto the shovel (left). The shovel is placed in front of the product and then the broom gently pushes the product into the shovel. In this way, several products can also be loaded. By applying a slight pressure during transport, the broom can protect the product from falling out. Unloading is done with a quick jerk to remove the products from the shovel and place them in a defined location.

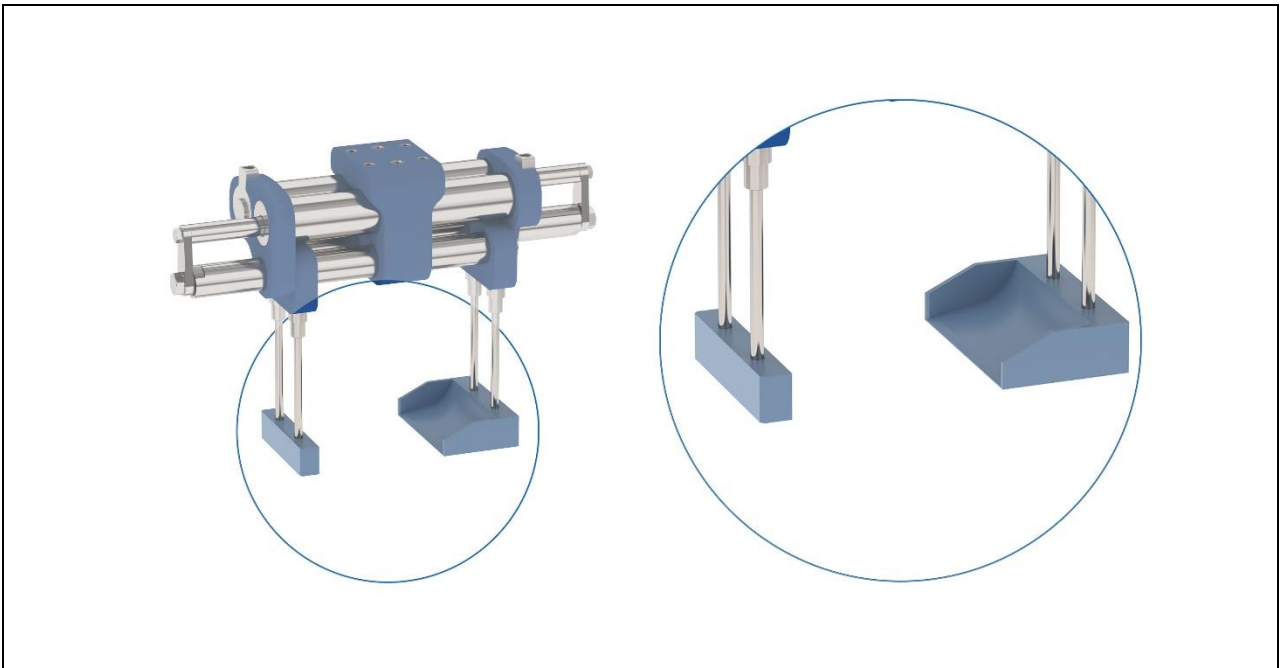



### 5.3 Large and/or flat products with adhesive surface

The clamping jaws are moved gently under the product to lift the sticky product carefully off the surface. Just before the product is set down, the gripper is opened halfway so that the product sticks to the subsurface. This allows the product to be precisely and gently set down again.

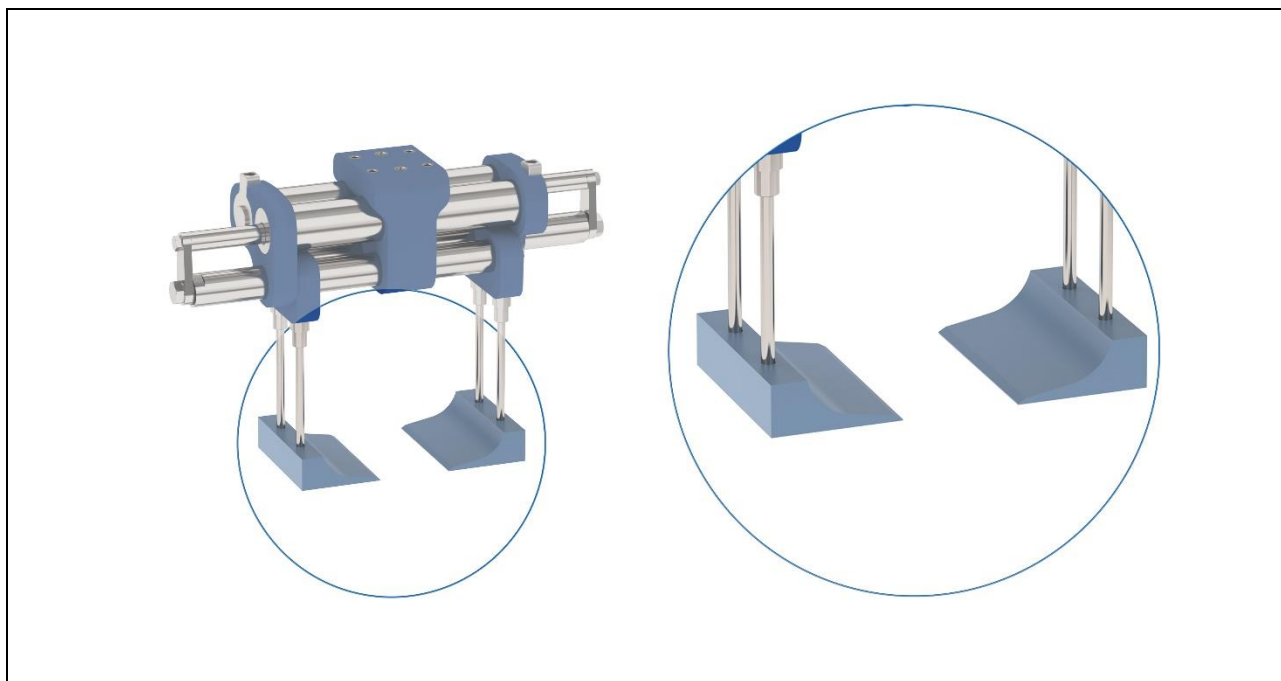

## 6 Material specifications

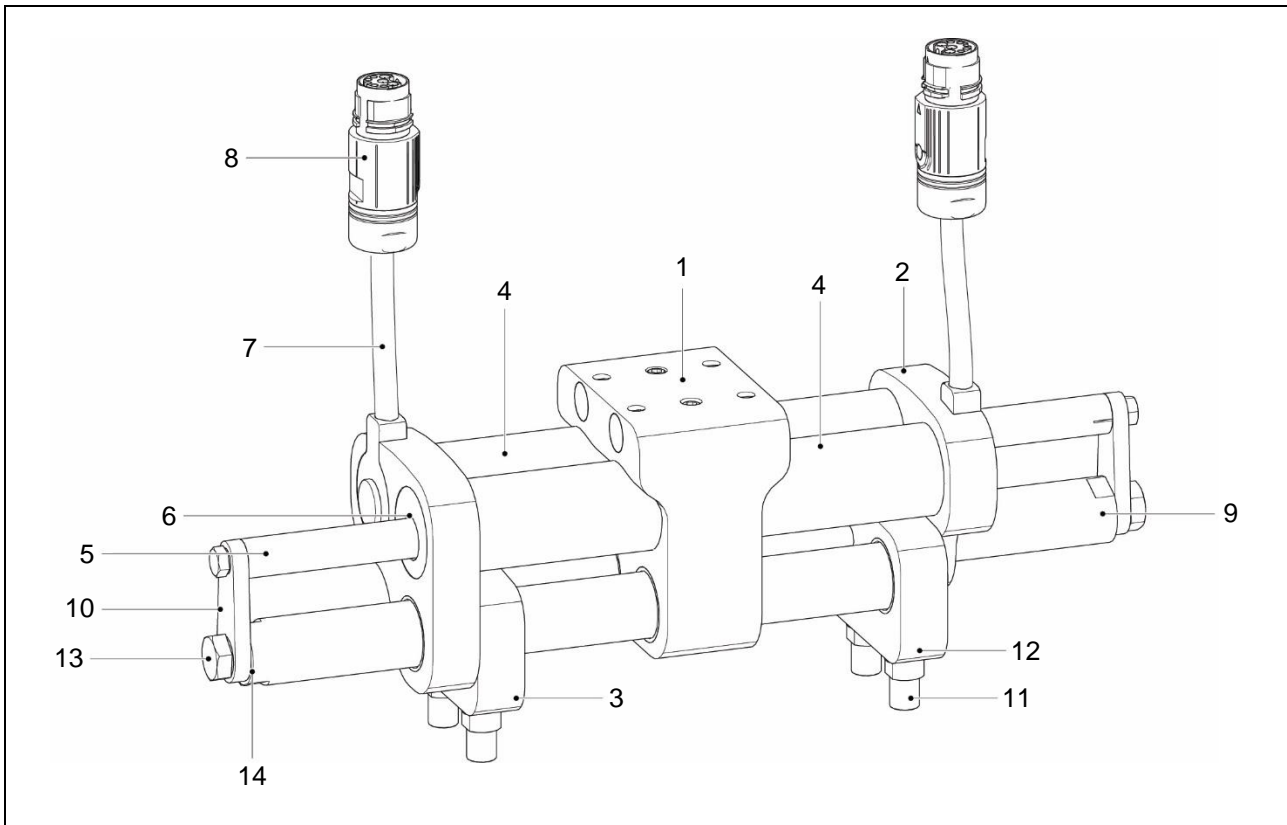

Pos.	Component	Material
1	Mounting flange	POM-C blue (FDA conform)
2	Endplate	POM-C blue (FDA conform)
3	Drive coupler	POM-C blue (FDA conform)
4	Stator linear motor	Stainless steel 1.4404 / 316L
5	Slider linear motor	Stainless steel 1.4404 / 316L
6	Wiper linear motor	H-PU blue (FDA conform)
7	Cable jacket linear motor	PUR
8	Connector housing linear motor	Zinc pressure casting, nickel-plated
9	Guide rod	Stainless steel 1.4404 / 316L
10	Connecting element	Stainless steel 1.4404 / 316L
11	Thread adapter gripper finger	Stainless steel 1.4404 / 316L
12	Thread inserts	Stainless steel 1.4404 / 316L
13	Screws for the connecting element	Stainless steel 1.4404 / 316L
14	Washers	Stainless steel 1.4301 / 304

<sup>1)</sup> The material 1.4404 is an austenitic chromium-nickel-molybdenum steel with the best corrosion resistance to acids and chlorine-containing substances. Its main area of application is in the food and chemical industries. The dark colouring of the guide rods comes from a special surface refinement. Thanks to this surface hardening, the surfaces are protected against mechanical wear.

<sup>2)</sup> POM-C material is intended for repeated use in contact with foods of all types, I through IX, with the exception of beverages containing alcohol in excess of 15% by volume and infant formula and breast milk. The composition of POM-C meets the requirement of FDA regulations 21 CFR § 177.2470 "Polyoxymethylene copolymer", 21 CFR § 178.3297 "Colourant for polymers" and other applicable FDA regulations.

## 7 Electrical Connection



Only connect or disconnect the motor connector when no voltage is applied to the servo drive. Only original LinMot cables may be used for wiring the motor. Pre-assembled cables may only be made from original LinMot accessories and must be carefully checked before commissioning.  
Incorrect motor wiring can damage the motor and/or the servo drive!

### 7.1 Motor cable



Individual cable lengths (max. 8 m) are available **on request**.

#### 7.1.1 Technical data

	High-Flex-Cable
Cable type	KS05-04/05
Cable length	1500 mm (59.06 in)
Cable diameter	9.5 mm (0.38 in)
Min. bending radius static	30 mm (1.2 in)
Min. bending radius moving	60 mm (2.4 in) no torsion
Approval	UL / CSA 300V / E172204
AWM style	21198
Core insulation material	TPE-U
Cable jacket material	PUR
Oil resistance	Very good according to DIN VDE 0282 Part 10 + HD 22.10
Chem. resistance to: acids, alkalis, solvents, hydraulic fluid	Good
Flammability	Flame retardant

### 7.2 Motor connector

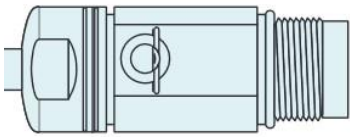
	Motor connector R/m
Material	Nickel-plated
Max. tightening torque	0.6 Nm
Protection class	IP67S
	

### 7.2.1 Pin assignment R-connector

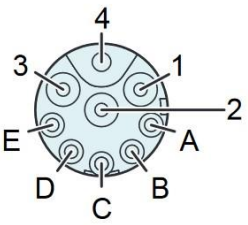
Connector type	R-connector
	<b>PIN</b>
Phase1+	1
Phase1-	2
Phase2+	3
Phase2	4
+5V	A
GROUND*	B
Sensor Sin.	C
Sensor Cos.	D
Temp sensor	E
SHIELD* of stator and stator cable	Case
Stator connector	

### 7.3 Additional protection for the plug connection

The motor cable connection with IP67 protection class is intended for installation outside the cyclic cleaning area. The plug connection can alternatively be housed in an additional box with a higher protection class to protect the connector from direct use of high-pressure cleaners.



Connectors made of stainless steel 1.4404 and protection class IP69K are **available on request**.

In certain applications, the use of a heat shrinkable sleeve may also be sufficient to prevent water penetration or to protect against corrosion.

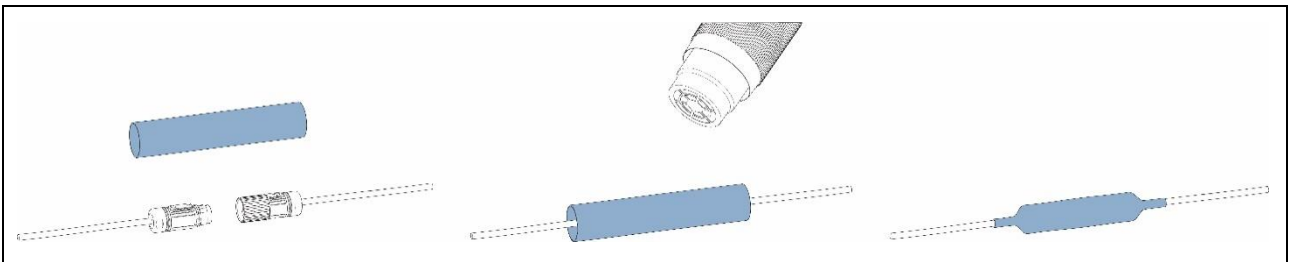

#### Ordering information

Item	Description	Item-No.
MCP01-18	Shrink tube with heat activated sealant for IP67 connectors	<a href="#">0150-3089</a>

## 8 Start-up

### 8.1 Setting the parameters



To configure the gripper module, use the LinMot-Talk software from version 6.9. The software and the associated detailed user manual can be downloaded from <https://linmot.com/download/linmot-talk-drive-configuration/>

### 8.2 Plug-and-Play

LinMot gripper modules are plug and play. This means that they automatically log on to the drive. The module and motor specific parameters are automatically stored in the drive and the motor is ready for use.

If the motor file is not automatically found in the installation directory of the software, the file can be downloaded using the LinMot-Talk software, as shown below.

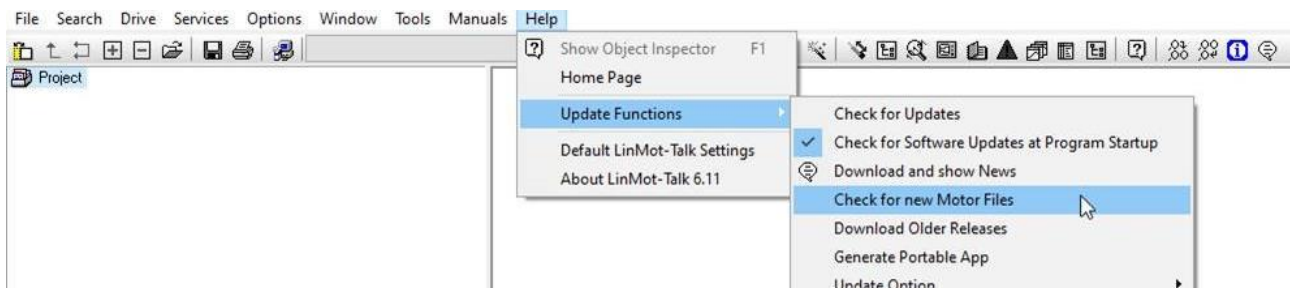

#### 8.2.1 Application-specific parameters

Application specific parameters such as cable length, load mass, PID control settings etc. can be entered by the user via the Motor Wizard. Click on the Motor Wizard icon in the task bar of the LinMot-Talk software.

The Motor Wizard will guide the user through the menu step by step. The application parameters should be entered as accurately as possible to ensure the best possible motor control.

#### 8.2.2 Referencing the linear motor

The built-in linear motor has a position detection system that must be referenced. Several modes are available to the user for this purpose. Depending on the mode selected, the linear motor will, for example, search for a mechanical stop in the open or closed position.

#### 8.2.3 Current/force limitation of the linear motor

The actuators are controlled by position specification as standard. If the actuator hits a mechanical stop or something gets in the way, the actuator will apply the maximum force/current to hold the position or follow the target position. The high current drawn over a long period of time will cause the actuator to heat up or overheat. For this reason the current consumption should be limited in certain cases:

- Positioning on a fixed stop
- Gripping hard products
- Gripping sensitive products

#### Control example for smooth gripping

When gripping products with different or non-solid shapes, both gripper jaws are started with the target position "fully open" and the force is limited. The actuator is stopped as soon as the current increases in the respective actuator. As soon as the object is gripped, the force required for transport can be set. This allows a product to be gripped gently. To ensure precise positioning of the product, the gripper fingers on one side can move to an absolute position with a higher current, which causes the gripper fingers on the other side to move automatically. Opening takes place by specifying the target position of the two motors for the open state.

**Current limitation in LinMot-Talk**

Function	Parameter	UPID
Bi-directional current limit	Maximal Current	13A6h
Positive current limit	Maximal Current Positive	13FCh
Negative current limit	Maximal Current Negative	13FDh

## 9 Accessories

### 9.1 Motor cable

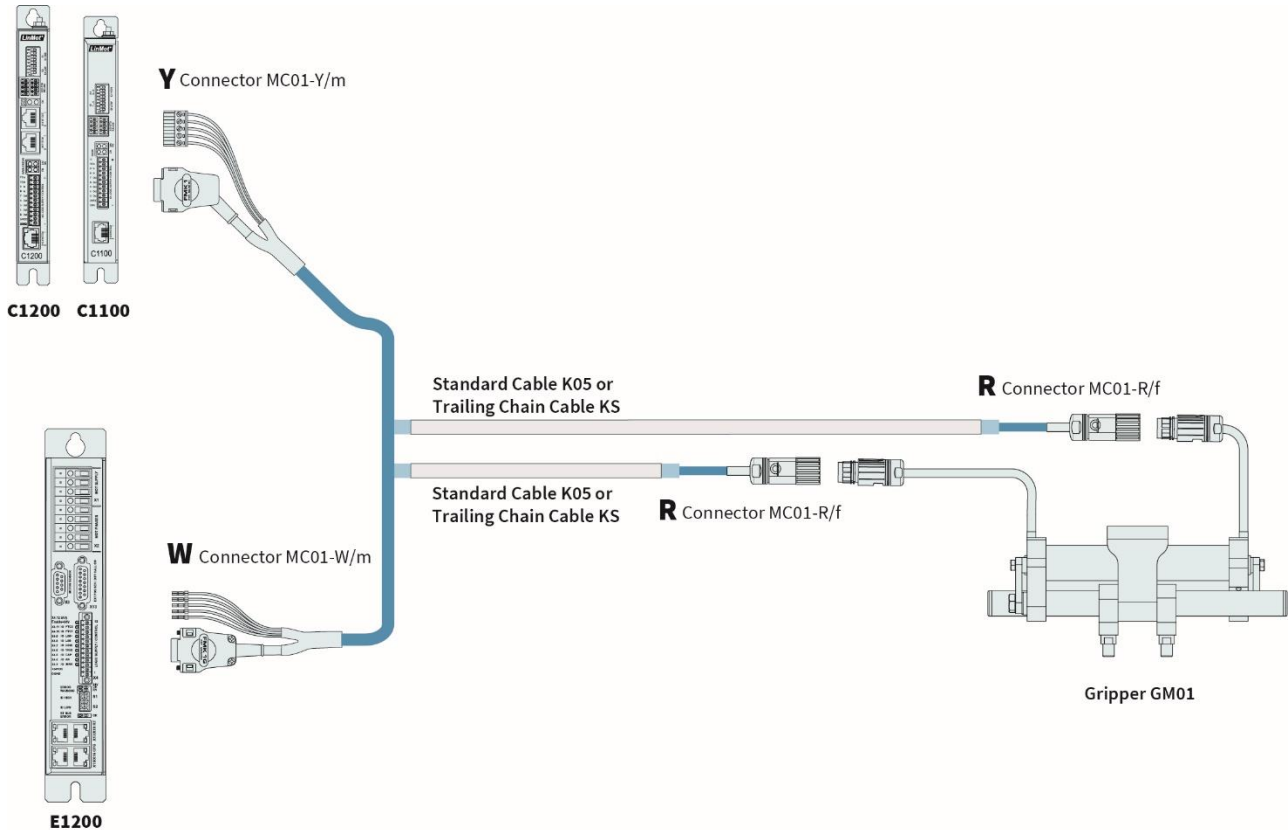

Item	Description	Item-No.
K05-W/R-2	Motor cable W/R, 2 m	<a href="#">0150-2119</a>
K05-W/R-4	Motor cable W/R, 4 m	<a href="#">0150-2120</a>
K05-W/R-6	Motor cable W/R, 6 m	<a href="#">0150-2121</a>
K05-W/R-8	Motor cable W/R, 8 m	<a href="#">0150-2122</a>
K05-W/R-	Motor cable W/R, custom length	<a href="#">0150-3262</a>

Item	Description	Item-No.
K05-Y/R-2	Motor cable Y/R, 2 m	<a href="#">0150-2421</a>
K05-Y/R-4	Motor cable Y/R, 4 m	<a href="#">0150-2422</a>
K05-Y/R-6	Motor cable Y/R, 6 m	<a href="#">0150-2423</a>
K05-Y/R-8	Motor cable Y/R, 8 m	<a href="#">0150-2424</a>
K05-Y-Fe/R-	Motor cable Y/R, custom length	<a href="#">0150-3501</a>

Item	Description	Item-No.
KS05-W/R-4	Trailing chain cable W/R, 4 m	<a href="#">0150-2106</a>
KS05-W/R-6	Trailing chain cable W/R, 6 m	<a href="#">0150-2131</a>
KS05-W/R-8	Trailing chain cable W/R, 8 m	<a href="#">0150-2107</a>
KS05-W/R-	Trailing chain cable W/R, custom length	<a href="#">0150-3256</a>

Item	Description	Item-No.
KS05-Y/R-2	Trailing chain cable Y/R, 2 m	0150-4165
KS05-Y/R-4	Trailing chain cable Y/R, 4 m	<a href="#">0150-2433</a>
KS05-Y/R-6	Trailing chain cable Y/R, 6 m	<a href="#">0150-2434</a>
KS05-Y/R-8	Trailing chain cable Y/R, 8 m	<a href="#">0150-2435</a>
KS05-Y-Fe/R-	Trailing chain cable Y-Fe/R, custom length	<a href="#">0150-3507</a>

Item	Description	Item-No.
KS05-R/R-2	Trailing chain cable R/R, 2 m	<a href="#">0150-1838</a>
KS05-R/R-4	Trailing chain cable R/R, 4 m	<a href="#">0150-1839</a>
KS05-R/R-	Special cable KS05-R/R-, custom length	<a href="#">0150-3217</a>

## 9.2 Extension cable



The motor cable is routed to the servo drive using an extension cable of the required length. The available cables are listed in chapter 9.

### 9.2.1 Extension connector with IP67S protection

	Motor connector R/f
Material	Nickel-plated
Max. tightening torque	0.6 Nm
Protection class	IP67S

## 9.3 Wiper

Wipers retain lubrication with LinMot LU02 food-grade grease in the stator and increase motor maintenance cycles.



Item	Description	Item-No.
PAW01-12-BL-Lf	Wiper low friction blau	0160-3403



## 10 Maintenance

### 10.1 Maintenance cycles of the gripper module

The plain bearings of the GM01 gripper module are provided with initial lubrication at the factory. The lubrication and inspection intervals depend primarily on the average moving speed, the operating temperature and the general ambient conditions. The following table with the inspection intervals is based on normal industrial, Central European conditions (5-day week with 8 hours operating time per day) and the use of the recommended bearing grease LU02.

#### Gripper module with plain bearings

Velocity [v]	Inspection interval [cycles]
$v < 1$ m/s	14.3 Mio.

Basically, the inspection cycle of the actuator unit must be shortened if there are heavy loads or deviating conditions. These are e.g.:

- Permanent soiling
- Direct sunlight
- Low humidity
- Outdoor operation
- Increased operating temperature
- Strong shocks or vibrations



It is recommended that inspection, assembly and disassembly of the gripper modules be carried out by the following trained companies:

- LinMot
- Companies qualified by LinMot

However, assembly, disassembly and inspection can also be carried out by the customer. (see chapters 10.2 to 10.4). Please note that improper inspection, assembly or disassembly can lead to premature wear of the wearing parts and/or damage to the gripper module and/or its components and may invalidate the warranty.

#### Ordering information

Item	Description	Item-No.
MP01_MT01_GM01-23_EX00_AS00	Maintenance GM01-23: Replacement of all wearing parts, cleaning and lubrication	0120-4800

### 10.2 Inspection



To ensure the best possible trouble-free operation, a preventive inspection is recommended every 6000 hours of operation or after one year.

The following points should be checked when inspecting the actuators:

- Visual inspection of all wearing parts (replace if necessary)
- Preventive replacement of seals and wipers
- Cleaning of mechanical moving parts
- Replacement and maintenance of ball / plain bearings if necessary

### 10.3 Troubleshooting

The following points must be checked during the troubleshooting:

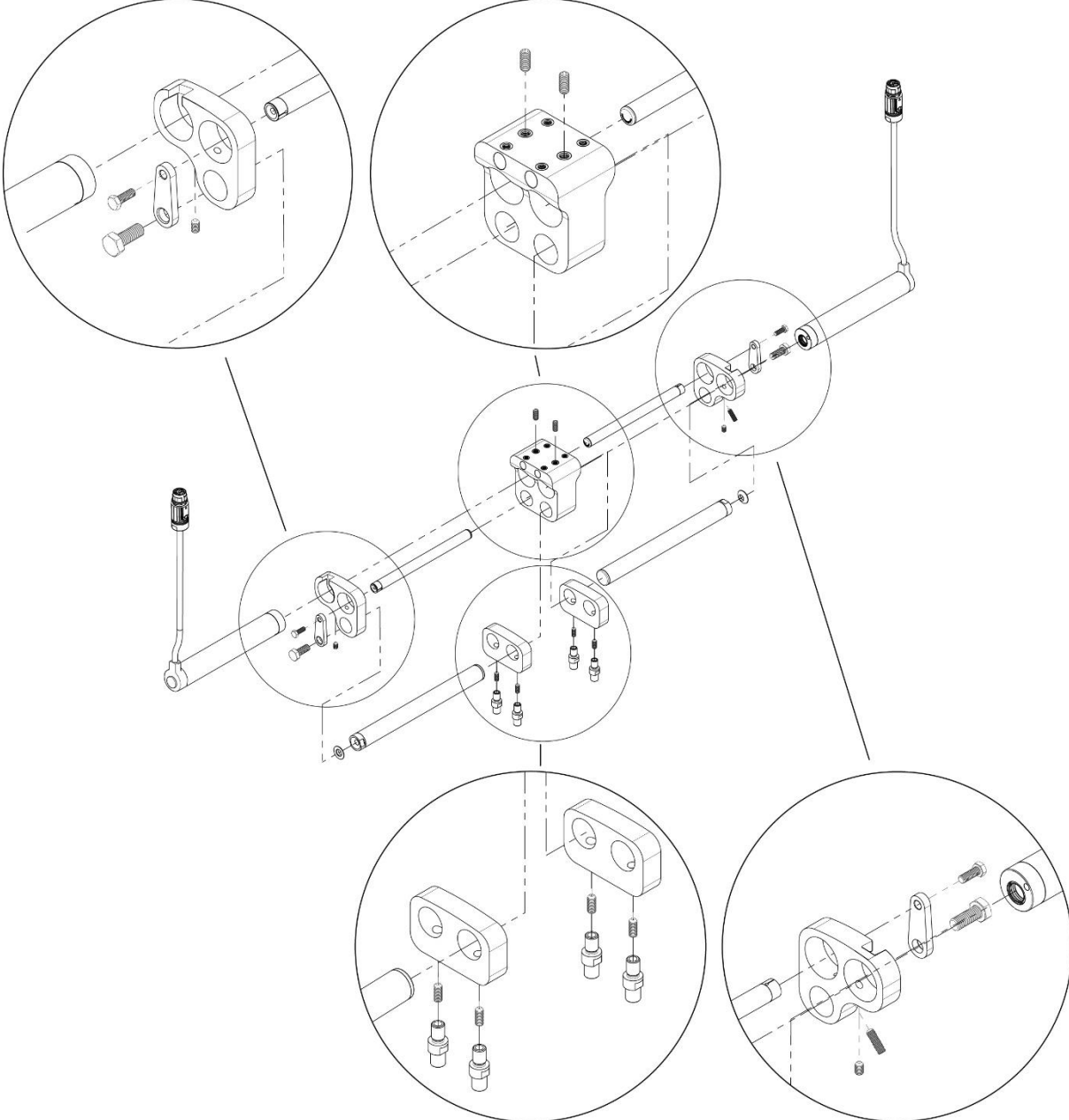
Problem	Solution
Do the gripper fingers have too much or too little play?	Yes -> Check the screw connections as shown.
	
Has the slider of the linear motor been relubricated?	No -> Loosen the connecting plate and dismantle the slider, clean and lubricate it.
Are the wipers of the linear motor damaged?	Yes -> reorder wipers and replace them.
Can the guide unit be moved smoothly?	No -> Loosen connecting element, check and gently align.

## 10.4 Cleaning and lubrication

### 10.4.1 Cleaning and lubrication of the linear motor

1. Loosen the connecting element and carefully pull the slider out of the stator. **Caution:** Large magnetic attraction forces (see warning on p. 5). If necessary, cover nearby iron structures with non-magnetic material (e.g. wood).
2. Clean the slider and stator with soft disposable paper, ideally with the aid of LU06 cleaning spray (alternatively methylated spirits or alcohol).
3. Carefully push the slider into the stator.
4. Gently fasten the connecting element, move it several times and then screw it tight.
5. Check the friction over the entire stroke and remove excess grease and dirt when moving the slider.



**Caution! Avoid over-greasing!** Over-greasing can lead to gumming of the grease, especially at higher operating temperatures. Remove excess grease while moving the slider.

### 10.4.2 Cleaning and lubrication of the guide rods

Lubrication of the guide shafts is optional, but can have a positive effect on the sensitivity of the gripper. This is particularly the case if product detection is to be based on current consumption, as the motor current is influenced by the force of movement, dry friction, sliding friction and external forces. A light film of grease will reduce the friction in the plain bearings, which in turn will make the frictional connection more sensitive.



When operating with grease, it should be made aware that the relubrication intervals are strongly dependent on the operating and ambient conditions. In addition to the drive loads in the form of stroke kilometres, speeds and surface pressure, the ambient conditions, such as temperature, draught, humidity and general contamination, also play a decisive role. It is therefore advisable to inspect the specific application regularly and to determine the relubrication intervals from this. The inspection intervals can be extended in stages.



The recommended lubricating grease LU02 is largely resistant to water and steam. Nevertheless, in applications where the gripper is regularly wet cleaned, the lubrication intervals should be shortened accordingly. If the cleaning process or the cleaning agent includes a targeted removal of the grease on the guide rods, relubrication is recommended after each cleaning process. Regreasing is carried out according to the following instructions:

1. Remove the old grease on the guide rods ideally with the help of LU06 cleaning spray (alternatively e.g. petroleum ether) with a soft cleaning cloth or paper towel.
2. Move the moving part of the gripper module back and forth several times so that the bearings are also degreased. **Note:** It is generally not necessary to dismantle the gripper module or remove the guide rods from the bearings.
3. Grease the guide rods carefully and completely with LU02 grease. Move the moving part of the gripper module back and forth. Remove any grease that has been wiped off. There should only be a thin film of grease on the guide rods.

#### Ordering information

Item	Description	Item-No.
LU06-250	Klüberfood NH1 4-002 Spray* (250 ml)	<a href="#">0150-2394</a>
LU02-50	Lubricant for linear motors** (50 g)	<a href="#">0150-1954</a>
LU02-1000	Lubricant for linear motors** (1000 g)	<a href="#">0150-1955</a>

\* LinMot Spray LU06 is identical with KLÜBERFOOD NH1 4-002 (Food grade UH1 approval).  
 \*\* LinMot Grease LU02 is identical KLÜBERSYNTH UH1 14-31 (Food grade UH1 approval).

## 11 Storage, Transport, Installation Altitude

- The storage area must be dry, dust-free, frost-free and vibration-free.
- The relative air humidity should be less than 60 %.
- Prescribed storage temperature: -15 °C...70 °C
- The motor must be protected against extreme weather conditions.
- The air in the storage area must not contain any harmful gases.

## 12 Dimensions & Weights

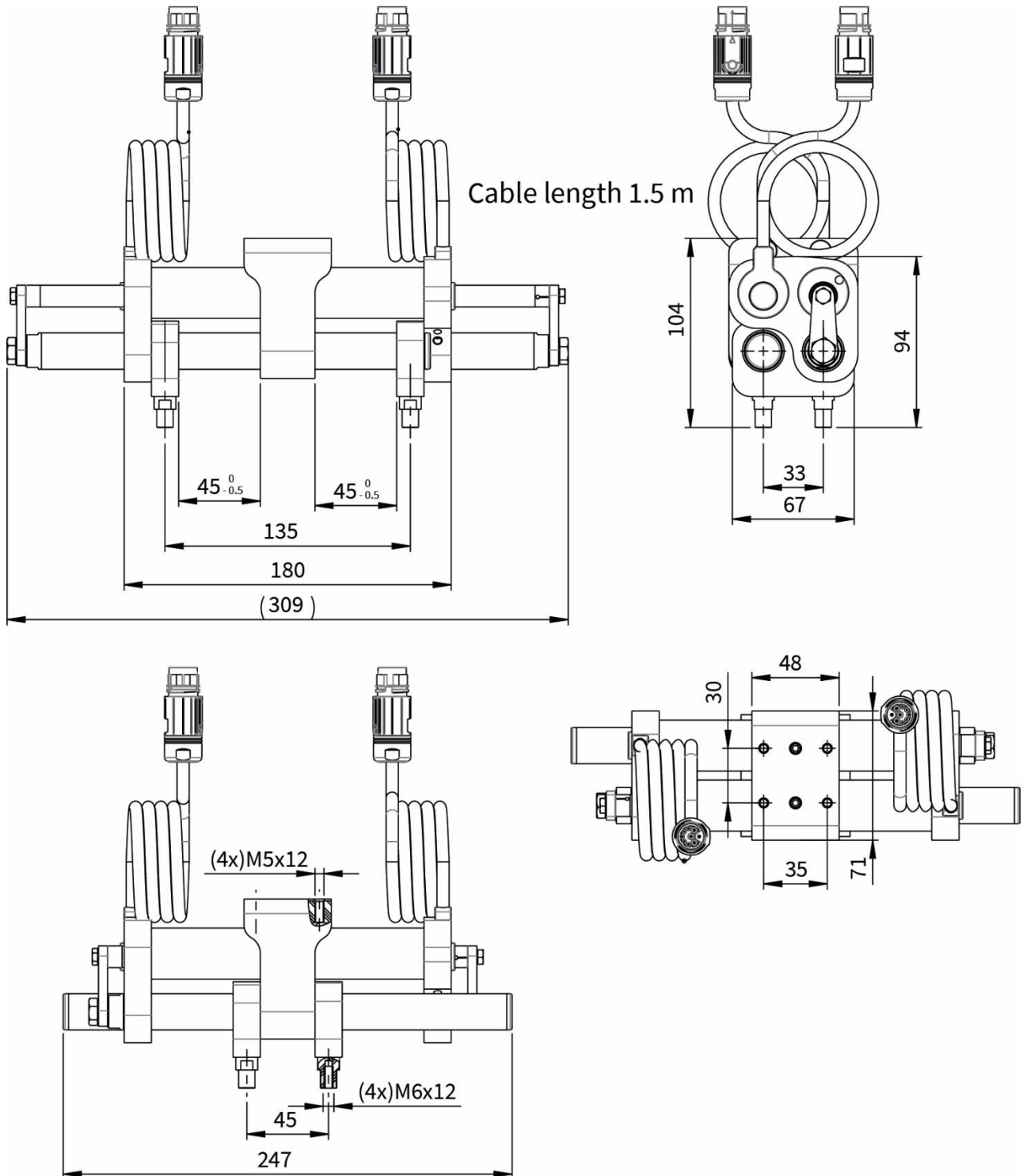

### 12.1 Gripper module GM01-23x80F-HP-R150-90-SSCP

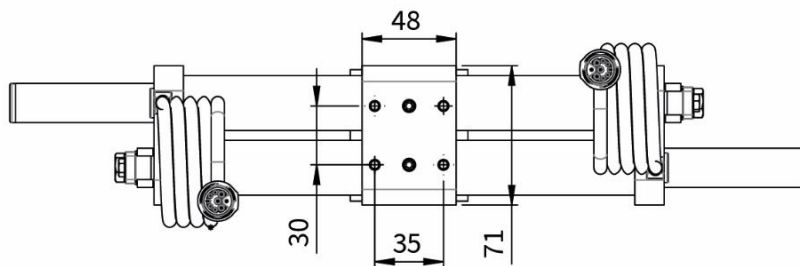
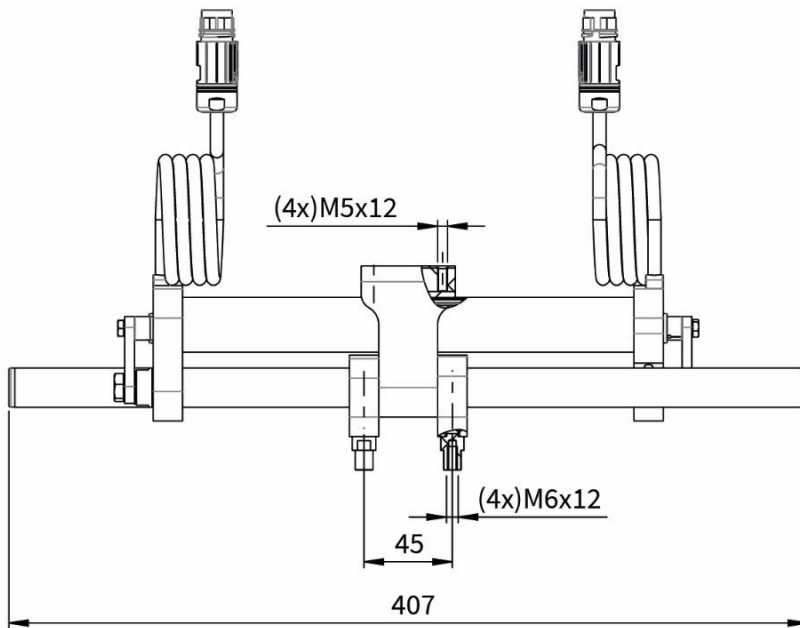
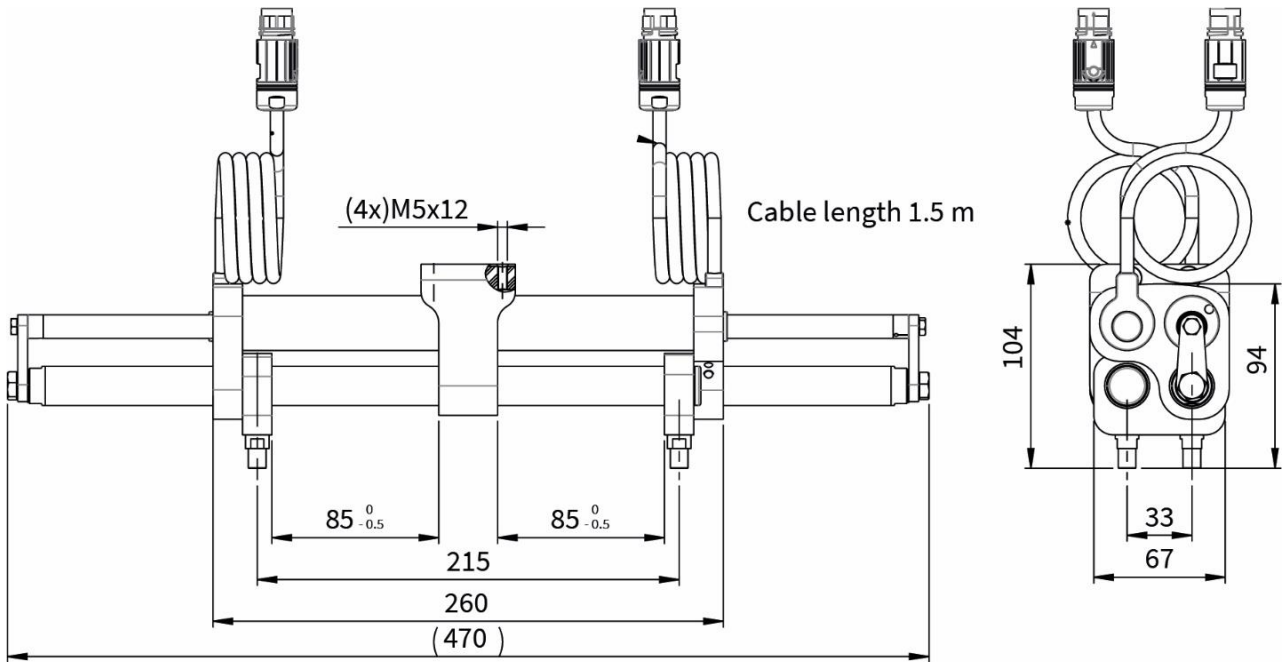

**12.2 Gripper module GM01-23x160H-HP-R150-170-SSCP**



**13 International Certificates**

<p>Europe</p> 	<p>See chapter “EU Declaration of Conformity CE-Marking”</p>
<p>UK</p> 	<p>See chapter “UK Declaration of Conformity UKCA-Marking”</p>
<p><b>IECEE CB SCHEME</b></p>	<p>Ref. Certif. Nr. CH-8521</p>
<p>USA / Canada</p> 	<p>Filenummer E354430 Refers to cURus marked motors</p>



Ref. Certif. No.

CH-8521

IEC SYSTEM FOR MUTUAL RECOGNITION OF TEST CERTIFICATES FOR ELECTRICAL EQUIPMENT (IECEE) CB SCHEME

**CB TEST CERTIFICATE**

Product	Linear motor	
Name and address of the applicant	NTI AG	Bodenackerstrasse 2 SWITZERLAND 8957 Spreitenbach
Name and address of the manufacturer	NTI AG	Bodenackerstrasse 2 SWITZERLAND 8957 Spreitenbach
Name and address of the factory	NTI AG	Bodenackerstrasse 2 SWITZERLAND 8957 Spreitenbach
<i>Note: When more than one factory, please report on page 2</i>	<input type="checkbox"/> Additional Information on page 2	
Ratings and principal characteristics	supplied via servo drive, see TR 17-EL-0006.E02 for details	
Trade mark (if any)	LinMot	
Customers's Testing Facility (CTF) Stage used	---	
Model / Type Ref.	PR series PS series P04 series P05 series	
Additional information (if necessary may also be reported on page 2)	---	
A sample of product was tested and found to be in conformity with IEC	<input type="checkbox"/> Additional Information on page 2	
National differences	IEC 61000-6-2:2016 IEC 61000-6-4:2006, IEC 61000-6-4:2006/AMD1:2010 IEC 61000-6-7:2014 EU Group Differences; EU Special National Conditions; EU A-Deviations	
As shown in the Test Report Ref. No. which forms part of this Certificate	17-EL-0006.E01 + .E02 + .Z01	



This CB Test Certificate is issued by the National Certification Body

Electrosuisse  
Luppenstrasse 1  
8320 Fehraltorf  
SWITZERLAND

Signed by: Martin Plüss  
Date: 2017-03-13





## CERTIFICATE OF COMPLIANCE

**Certificate Number** UL-US-2138367-0  
**Report Reference** E354430-20210817  
**Date** 23-Aug-2021

**Issued to:** NTI AG  
Bodenaeckerstr 2 SPREITENBACH  
Switzerland 8957

**This is to certify that representative samples of** NDMM2 - Incomplete Rotating Machines and Rotating Machine Parts - Component  
See Addendum Page for Product Designation(s).

Have been investigated by UL in accordance with the component requirements in the Standard(s) indicated on this Certificate. UL Recognized components are incomplete in certain constructional features or restricted in performance capabilities and are intended for installation in complete equipment submitted for investigation to UL LLC.

**Standard(s) for Safety:** UL 1004-1, 2nd Ed., Issue Date: 2012-09-19, Revision Date: 2020-11-05

**Additional Information:** See the UL Online Certifications Directory at <https://iq.ulprospector.com> for additional information

This *Certificate of Compliance* does not provide authorization to apply the UL Recognized Component Mark. Only the UL Follow-Up Services Procedure provides authorization to apply the UL Mark.

Only those products bearing the UL Recognized Component Mark should be considered as being UL Certified and covered under UL's Follow-Up Services.

Look for the UL Recognized Component Mark on the product.

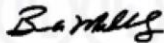

Bruce Mahrenholz, Director North American Certification Program

UL LLC

Any information and documentation involving UL Mark services are provided on behalf of UL LLC (UL) or any authorized licensee of UL. For questions, please contact a local UL Customer Service Representative at <http://ul.com/aboutul/locations/>



## 14 EU Declaration of Conformity CE-Marking

NTI AG / LinMot®  
Bodenaeckerstrasse 2  
8957 Spreitenbach

Switzerland

Tel.: +41 (0)56 419 91 91  
Fax: +41 (0)56 419 91 92

declares under sole responsibility the compliance of the products:

- Gripper modules of the **GM01** series  
with the EMC Directive 2014/30/EU.

Applied harmonized standards:

- **EN 61000-6-2: 2005 (Immunity for industrial environments)**
- **EN 61000-6-4: 2007 + A1: 2011 (Emission for industrial environments)**

According to the EMC directive, the listed devices are not independently operable products.

Compliance of the directive requires the correct installation of the product, the observance of specific installation guides and product documentation. This was tested on specific system configurations.

The safety instructions of the manuals are to be considered.

The product must be mounted and used in strict accordance with the installation instructions contained within the installation guide, a copy of which may be obtained from NTI AG.

Company: NTI AG  
Spreitenbach, 26/04/2024



Dr.-Ing. Ronald Rohner  
CEO NTI AG

## 15 UK Declaration of Conformity UKCA-Marking

NTI AG / LinMot®  
Bodenaeckerstrasse 2  
8957 Spreitenbach

Switzerland

Tel.: +41 (0)56 419 91 91  
Fax: +41 (0)56 419 91 92

declares under sole responsibility the compliance of the products:

- Gripper modules of the **GM01** series  
with the EMC Regulation S.I. 2016 No. 1091.

Applied designated standards:

- **EN 61000-6-2: 2005 (Immunity for industrial environments)**
- **EN 61000-6-4: 2007 + A1: 2011 (Emission for industrial environments)**

According to the EMC regulation, the listed devices are not independently operable products.

Compliance of the regulation requires the correct installation of the product, the observance of specific installation guides and product documentation. This was tested on specific system configurations.

The safety instructions of the manuals are to be considered.

The product must be mounted and used in strict accordance with the installation instructions contained within the installation guide, a copy of which may be obtained from NTI AG.

Company: NTI AG  
Spreitenbach, 26.04.2024



Dr.-Ing. Ronald Rohner  
CEO NTI AG

# ALL LINEAR MOTION FROM A SINGLE SOURCE

## Europe / Asia Headquarters

### NTI AG - LinMot & MagSpring

Bodenaeckerstrasse 2  
CH-8957 Spreitenbach  
Switzerland

Sales / Administration: +41 56 419 91 91  
[office@linmot.com](mailto:office@linmot.com)

Tech. Support: +41 56 544 71 00  
[support@linmot.com](mailto:support@linmot.com)

Web: <https://www.linmot.com/>

Visit <https://linmot.com/contact/> to find a distributor near you.

## North / South America Headquarters

### LinMot USA Inc.

N1922 State Road 120, Unit 1  
Lake Geneva, WI 53147  
USA

Sales / Administration: 262.743.2555  
[usasales@linmot.com](mailto:usasales@linmot.com)

Tech. Support: 262.743.2555  
[usasupport@linmot.com](mailto:usasupport@linmot.com)

Web: <https://www.linmot.com/>