

Installation Guide
Linear Modules
FM01-37

ENG



Content

1	General Information	4
1.1	Introduction	4
1.2	Explanation of Symbols	4
1.3	Qualified Personnel	4
1.4	Liability	4
1.5	Copyright	4
2	Safety Instructions	5
3	Intended Use	7
3.1	Designation code	7
3.2	FM01 Linear Module	7
3.3	Intended installation	9
3.4	Mechanical variants BE0x and MD0x	9
3.5	Arrangement for multi carriage guidance	10
3.6	Option external sensor	10
3.7	Technical data carriage kits	11
4	Installation Instructions	12
4.1	Installation options	12
4.1.1	Installation examples	12
4.2	Installation of the load	14
4.2.1	Mounting plate FM01-37S...37Sx60	14
4.2.2	Mounting plate FM01-37S...37Sx120	15
4.3	Cantilever linear modules	16
4.3.1	Cantilever linear modules with mounting on one side	16
4.3.2	Cantilever linear modules with double-sided or multiple mountings	17
5	Electrical Connection	18
5.1	Motor cable	18
5.2	N-connector wiring	18
6	Start-up	19
6.1	LinMot drive setup	19
6.2	Standard values of the coordinate system / standard installation stator	19
6.3	Setting the Parameters	19
6.3.1	Defining Payload	19
6.3.2	PID Controller	19
6.3.3	Achieving Full Stroke Length	19
6.4	Master-slave configuration	20
7	Accessories	21
7.1	Trailing chain kits	21
7.1.1	Dimensions	21
7.1.2	Overview trailing chain kit	22
7.2	Assembly of the trailing chains	23
7.2.1	Standard installation of the trailing chain on one carriage (0140-0050 option (default): Cable connector bottom left)	26

7.2.2	Inverted installation of the trailing chain on one carriage (0140-0051 option: Cable connector bottom right)	28
7.2.3	Cable exit on the centre with two carriages (0140-0052 option (default): Cable connector bottom center)	30
7.2.4	Cable exit on the sides with two carriages (0140-0053 option: Cable connector left/right)	33
7.2.5	Cable exit left/centre with two carriages (0140-0054 option: Cable connector bottom left/centre)	36
7.2.6	Cable exit centre/right with two carriages (0140-0055 option: Cable connector bottom centre/right)	39
7.3	Motor cables	42
7.3.1	Motor cables for direct wiring	42
7.3.2	Motor cables for indirect wiring with fixed extension cable	43
8	External Sensors	44
8.1	Incremental sensor	45
8.1.1	Overview sensor kit (incremental)	45
8.1.2	Dimensions	46
8.1.3	Magnetic strips for incremental sensor	46
8.1.4	Extender incremental sensor cable	47
8.2	Absolute sensor BiSS	47
8.2.1	Magnetic strips for absolute sensor BiSS	48
8.2.2	Absolute sensor BiSS cables	48
8.3	Absolute sensor BiSS for FM01-37x120 modules	49
8.3.1	Magnetic strips for absolute sensor BiSS	49
8.3.2	Absolute sensor BiSS cables	50
9	Maintenance	51
9.1	Maintenance cycles	51
9.1.1	Profile rail guide maintenance cycles	51
9.1.2	Linear motor (stator and slider) maintenance cycles	51
9.2	Inspection	51
9.3	Cleaning and lubrication	52
9.3.1	Profile rail guides and carriages cleaning and lubrication	52
9.3.2	Linear motor (stator and slider) cleaning and lubrication	52
10	Storage and Transport	53
11	Dimensions & Weights	54
11.1	FM01-37-xxx_xxx_1CF37Sx60-HP	54
11.2	FM01-37-xxx_xxx_1CF37x120F-HP	55
11.3	End plates	56
11.4	Mounting plate FM01-37-xxx_xxx_1CF37Sx60-HP	57
11.5	Mounting plate FM01-37-xxx_xxx_1CF37Sx120F-HP	58
12	International Certificates	59
13	EU Declaration of Conformity CE-Marking	61
14	UK Declaration of Conformity UKCA-Marking	62

1 General Information

1.1 Introduction

This manual includes instructions for the assembly, installation, maintenance, transport, and storage of linear guides / linear modules. The document is intended for electricians, mechanics, service technicians, and warehouse staff.

Read this manual before using the product and observe the general safety instructions and those in the relevant section at all times.

Keep these operating instructions in an accessible place and make them available to the personnel assigned.

1.2 Explanation of Symbols



Triangular warning signs warn of danger.



Round command symbols tell what to do.

1.3 Qualified Personnel

All work such as installation, commissioning, operation and service of the product may only be carried out by qualified personnel.

The personnel must have the necessary qualifications for the corresponding activity and be familiar with the installation, commissioning, operation and service of the product. The manual and in particular the safety instructions must be carefully read, understood and observed.

1.4 Liability

NTI AG (as manufacturer of LinMot and MagSpring products) excludes all liability for damages and expenses caused by incorrect use of the products. This also applies to false applications, which are caused by NTI AG's own data and notes, for example in the course of sales, support or application activities. It is the responsibility of the user to check the data and information provided by NTI AG for correct applicability in terms of safety. In addition, the entire responsibility for safety-related product functionality lies exclusively with the user. Product warranties are void if products are used with stators, sliders, servo drives or cables not manufactured by NTI AG unless such use was specifically approved by NTI AG.

NTI AG's warranty is limited to repair or replacement as stated in our standard warranty policy as described in our "terms and conditions" previously supplied to the purchaser of our equipment (please request copy of same if not otherwise available). Further reference is made to our general terms and conditions.

1.5 Copyright

This work is protected by copyright.

Under the copyright laws, this publication may not be reproduced or transmitted in any form, electronic or mechanical, including photocopying, recording, microfilm, storing in an information retrieval system, not even for training purposes, or translating, in whole or in part, without the prior written consent of NTI AG.

LinMot® and MagSpring® are registered trademarks of NTI AG.

2 Safety Instructions



Contusions

Sliders contain neodymium magnets and have a strong attractive force. Careless handling could cause fingers or skin to become pinched between two sliders. This may lead to contusions, bruises, and bone fractures. When handling sliders, wear thick protective gloves and keep a minimum distance between sliders. Refer to the "Minimum distance from slider" section for minimum distance.

To reduce the risk of injury, never more than one slider should be held or transported by the same person without packaging.



Pacemaker / Implanted Heart Defibrillator

Sliders could affect the functioning of pacemakers and implanted heart defibrillators. For the duration of a strong approach to a magnetic field, these devices switch into test mode and will not function properly.

- If you wear one of those devices keep the following minimum distances between the pacemaker / defibrillator and slider:
 - Min. 250 mm (10") for slider Ø 27 mm and 28 mm (PL01-27 / 28 / PL10-28)
 - Min. 150 mm (6") for slider Ø 19 mm and 20 mm (PL01-19 / 20)
 - Min. 100 mm (4") for slider Ø 12 mm (PL01-12)
- Inform others who wear these devices to comply with these minimum distances!



Caution - Risk of Electric Shock !

Before working, make sure that there are no high voltages.



Fast-moving Machine Parts

The sliders of LinMot linear motors are fast-moving machine parts. All necessary precautions must be taken to prevent persons approaching the moving elements during operation (provide covers, guards, etc.).



Automatic Restart

The motors can start automatically under certain circumstances! If necessary, a corresponding warning symbol must be provided and protection against entering the hazardous area or a suitable safe electronic disconnection must be provided!



Risk of Injury due to a Defect or Fault

For areas where a defect or fault can result in substantial property damage or even serious personal injury, additional external precautions must be taken or devices must be installed to ensure safe operation even if a defect or fault occurs (eg. suitable safe electronic disconnection, mechanical interlocks, barriers, etc.).



Magnetic Field

Magnets integrated in the sliders produce a strong magnetic field. They could damage TVs, laptops, computer hard drives, credit and ATM cards, data storage media, mechanical watches, hearing aids, and speakers.

- Keep magnets away from devices and objects that could be damaged by strong magnetic fields.
- For the above mentioned objects, keep a minimum distance as described in the "Pacemaker / implanted defibrillator" section.
- For non-anti-magnetic watches, keep the double minimum distance.

**Combustibility**

When machining magnets, the drilling dust could easily ignite. Machining the sliders and the magnets they contain is not permitted.

**Burn Hazard**

During operation the slider can become hotter than 100 °C, which can cause burns if touched. All necessary precautions (e.g. covers, casing, etc.) must be taken to prevent contact with persons in the vicinity of the slider during operation.

**Grounding**

All metal parts that are exposed to contact during any user operation or servicing and likely to become energized shall be reliably connected to the means for grounding.

**Mechanical Handling**

Neodymium magnets are brittle and heat-sensitive. Machining the sliders and the magnets they contain is not permitted.

- Colliding magnets could crack. Sharp splinters could be catapulted for several meters and cause eye injury.
- By machining the sliders, heat would result which demagnetizes the magnets.

**2S Stators**

Series 2S stators correspond mechanically to the respective standard stators and are to be handled in exactly the same way in terms of assembly. For special features, please refer to the safety manual (Item-No. 0185-1174).

**Slider**

Linear motor sliders consist of a high-precision, thin-walled stainless steel tube in which the neodymium magnets are housed. The LinMot sliders should be handled with care. Avoid contact with other sliders or iron parts as this can damage the magnets and the slider surface. Do not grip the sliders with pliers, as this can also damage the surface. Do not use sliders which are already damaged on the surface (scratches, deformation, etc.). This can cause further damage to the stator.

**Effects on People**

According to the current level of knowledge, magnetic fields of permanent magnets do not have a measurable positive or negative effect on people. It is unlikely that permanent magnets constitute a health risk, but it cannot be ruled out entirely.

- For your own safety, avoid constant contact with magnets.
- Store large magnets at least one meter away from your body.

**Temperature Resistance**

Keep slider away from unshielded flame or heat. Temperature above 120°C will cause demagnetization.

3 Intended Use

3.1 Designation code

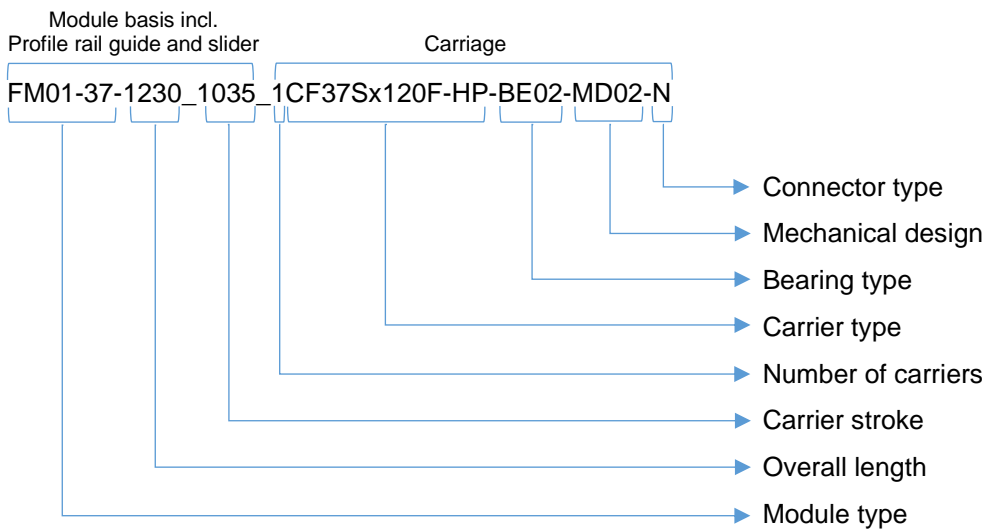

3.2 FM01 Linear Module

LinMot FM01 linear modules are moving stator applications with tubular linear motors for use in industrial and commercial installations. The mechanical construction is based on a special aluminium profile to which a high-precision profile rail guide is attached. Use of ball bearings in the carriages guarantee a reliable and smooth operation, support of external forces, torques and bending moments. These products offer high guidance accuracy, facilitate dynamic and precise positioning of load. FM01 modules can be mounted together into a gantry or semi gantry designs without any additional adapters. It is also possible to run multiple stators on the same guide. Direct mechanical compatibility with other LinMot linear modules for the vertical axis, linear rotary motors and other products, combined with the wide range of stroke availabilities for all axes, the moving stator guides offer a powerful toolbox for any automation task.

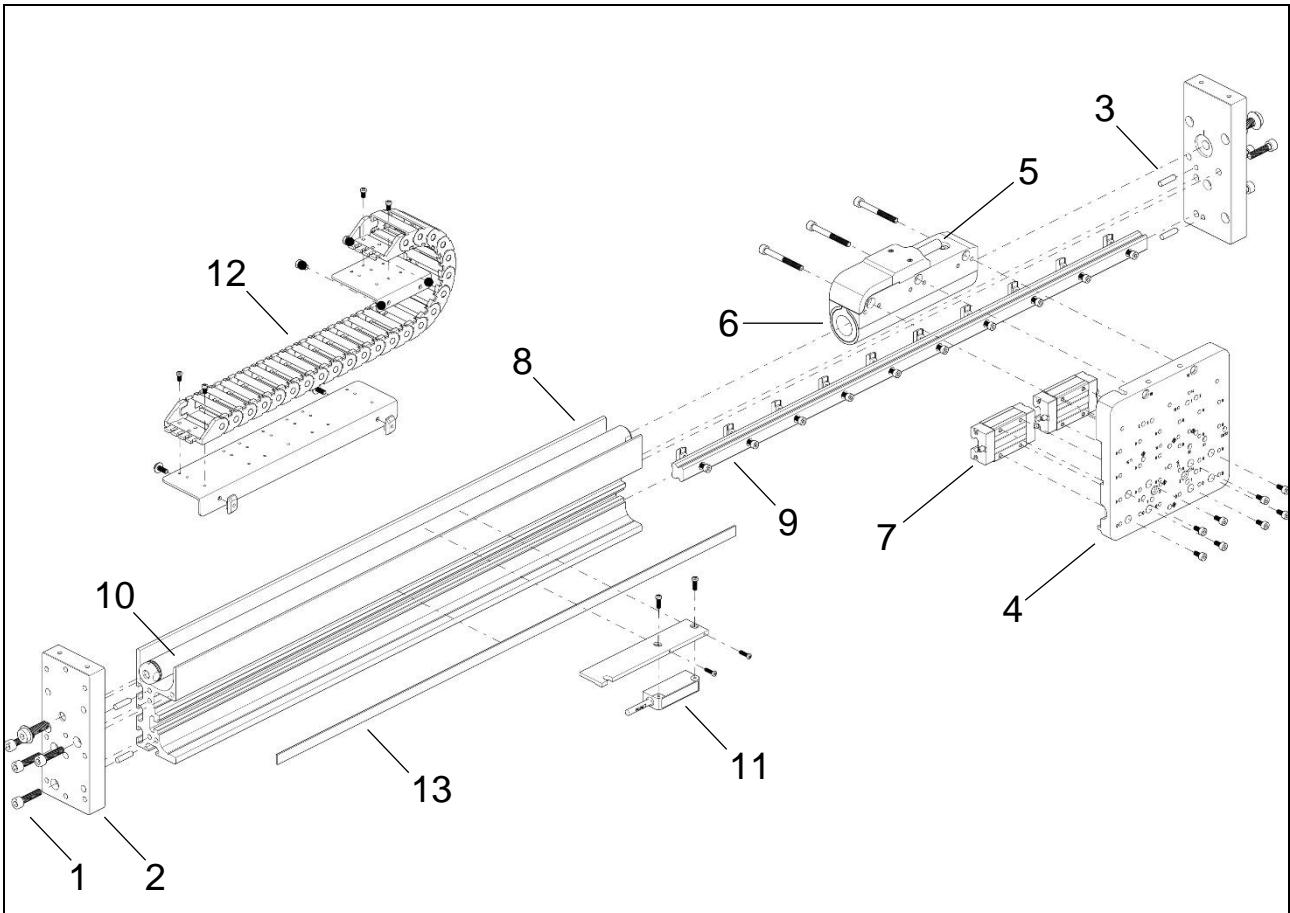

Number	Item
1	Cylinder screw
2	End plate
3	Parallel pin
4	Mounting plate
5	Connector
6	Stator
7	Bearing
8	Module basis
9	Profile rail guide
10	Slider
11	External sensor (set, optional)
12	Trailing chain kit (optional)
13	Magnetic strip

3.3 Intended installation

The following provisions apply to the installation of the FM01 linear modules:



- When mounting the linear module, the module basis should be pressed onto the reference surface to achieve the best accuracy and alignment.
- To mount the FM01 linear modules, use the end plates on both sides with the holes provided.
- The module basis is provided with T-slots along the entire length at the bottom and back. These serve to provide additional support for the module and can be used for assembly. Depending on the length of the guide and the application, a sufficient number of slot nuts must be used.
- The mounting option "horizontal attachment" is only permitted up to a length of 1200 mm and only with cross table trailing chains.

3.4 Mechanical variants BE0x and MD0x

Depending on the version, linear modules EM01 have different bearings or different mechanical structures/variants. These are listed in the designation code of the linear modules EM01 as follows:



Bearing types (BE_{xx}):

- BE01 = Each carriage has 1 bearing per profile rail
- BE02 = Each carriage has 2 bearing per profile rail

Mechanical construction (MD_{xx}):

- MD01 = Carriage with fixed stator (standard for stroke < 1000 mm)
- MD02 = Carriage with flexible stator (standard for stroke > 1000 mm)

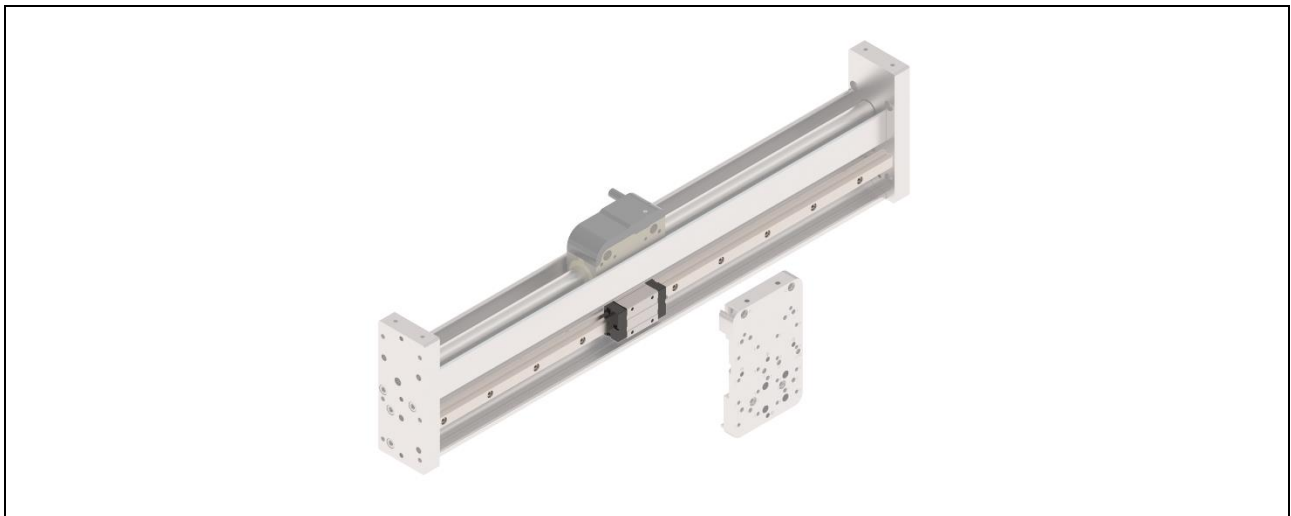

Variant "BE01": The carriage of the linear module is equipped with 1 bearing on the profile rail.



Variant "BE02": The carriage of the linear module is equipped with 2 bearings on the profile rail.

3.5 Arrangement for multi carriage guidance

Please note that for multiple carriage operation the carriage numbering is ascending from left to right. Each carriage has its own label showing the carriage position number (Axis 1, Axis 2, Axis 1+n). Important: The counting direction as well as the direction indications "right", "left" and "centre" are always to be understood from the front of the module (see illustration).

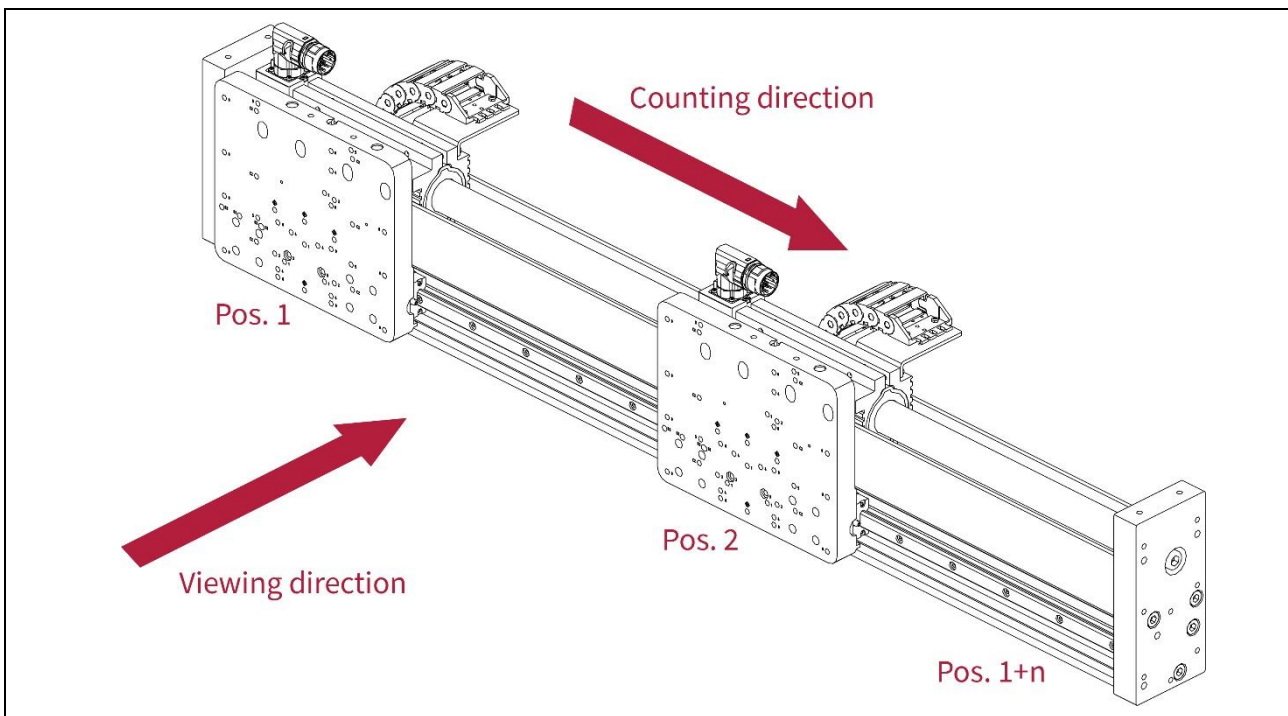

3.6 Option external sensor

Next to the LinMot linear stator's own integrated position sensors, both incremental and absolute external encoders are available as an option for the FM01 moduls. Together with a magnetic band, the external sensors provide a high-resolution linear measurement system.

3.7 Technical data carriage kits

The values for mass and friction are important for the configuration assistant of the LinMot-Talk software.

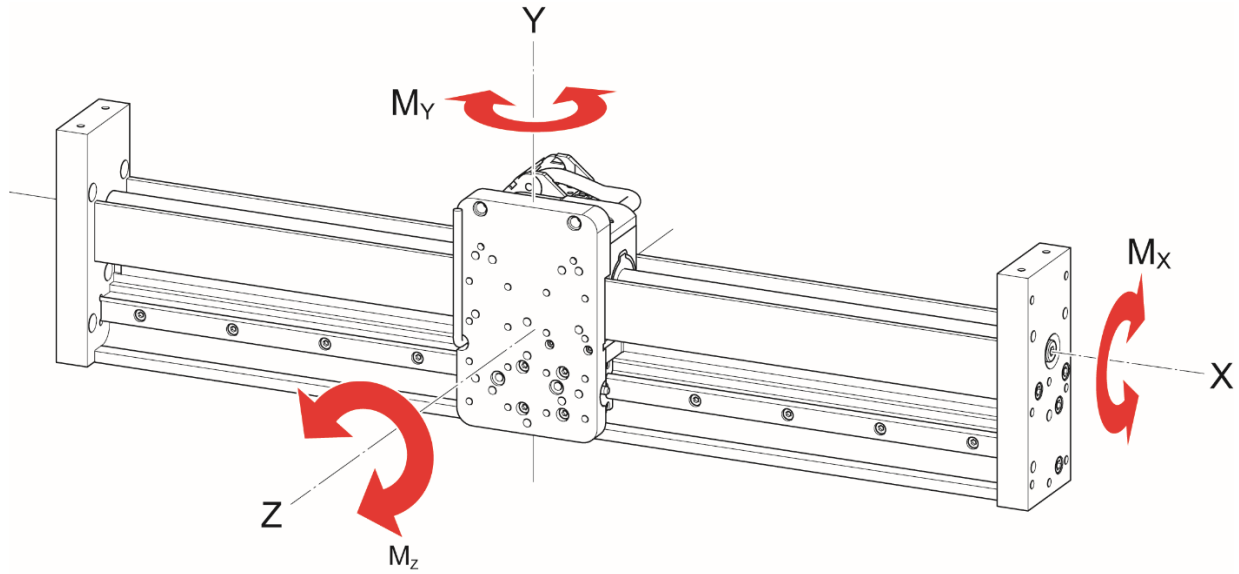

FM01-...	...37Sx60...		...37Sx120...	
Static Load Rating (per bearing)	15400 N	(3462.1 lbs)	15400 N	(3462.1 lbs)
Dynamic Load Rating (per bearing)	8400 N	(1888.4 lbs)	8400 N	(1888.4 lbs)
Static Moment Load M_{x0} (per bearing)	103 Nm	(911.6 lbfin)	103 Nm	(911.6 lbfin)
Static Moment Load $M_{y0/z0}$ (per bearing)	90 Nm	(796.6 lbfin)	cannot occur ¹	
Dynamic Moment Loads M_x (per bearing)	56 Nm	(495.6 lbfin)	56 Nm	(495.6 lbfin)
Dynamic Moment Loads $M_{y/z}$ (per bearing)	49 Nm	(433.7 lbfin)	cannot occur ¹	
Friction (estimated)	10 N	(2.25 lbs)	10 N	(2.25 lbs)
Moving mass	591 g	(1.30 lb)	1579 g	(3.48 lb)
Number of Carriages	1		2	
Distance between Bearings on the same Profile Rail	-		79 mm	(3.11 in)
Distance between profile rail and mounting surface	32 mm	(1.26 in)	32 mm	(1.26 in)

¹ Due to the arrangement of the bearings, the moment can no longer occur. It is converted by the bearings into a force acting vertically on the bearings (see static and dynamic load capacity). The following applies:
 Option BE02: Two bearings on one profile rail - a total of 1 profile rail guide: M_y and M_z are converted into forces.

4 Installation Instructions

4.1 Installation options

There are several options available for mounting the FM01 linear modules.

The module basis as well as the end plates are equipped with fits for parallel pins, bores and counterbores. Parallel pins may only be used to align the guide and are not intended for mounting. Mounting is done by using bores or counterbores. Additional brackets or adapters shown in examples may be required. These must be provided by the customer.

The following sketches show examples of different installation options. The detailed dimensions can be found in chapter 11 "Dimensions".

4.1.1 Installation examples

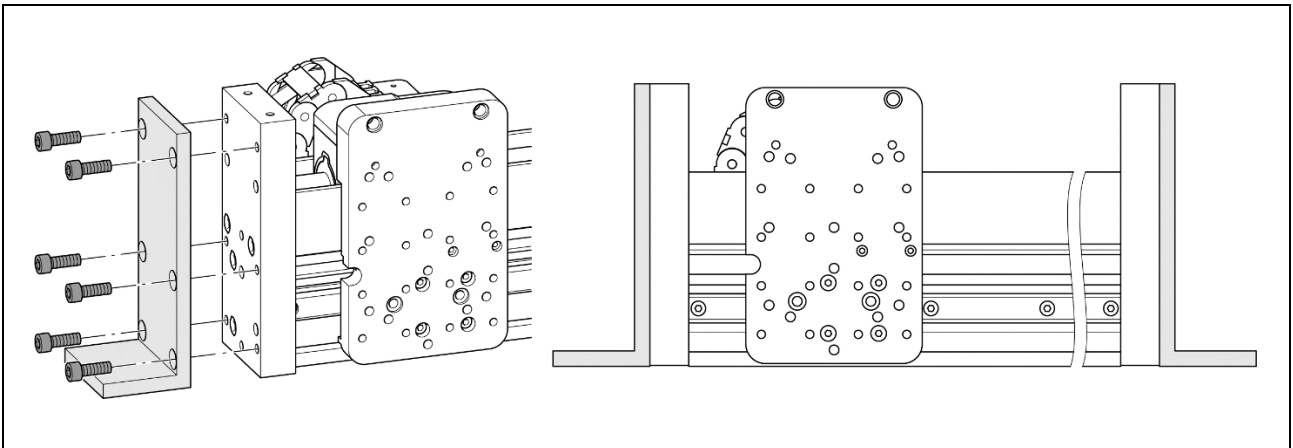

Example 1: Upright fixing using end plates and brackets.

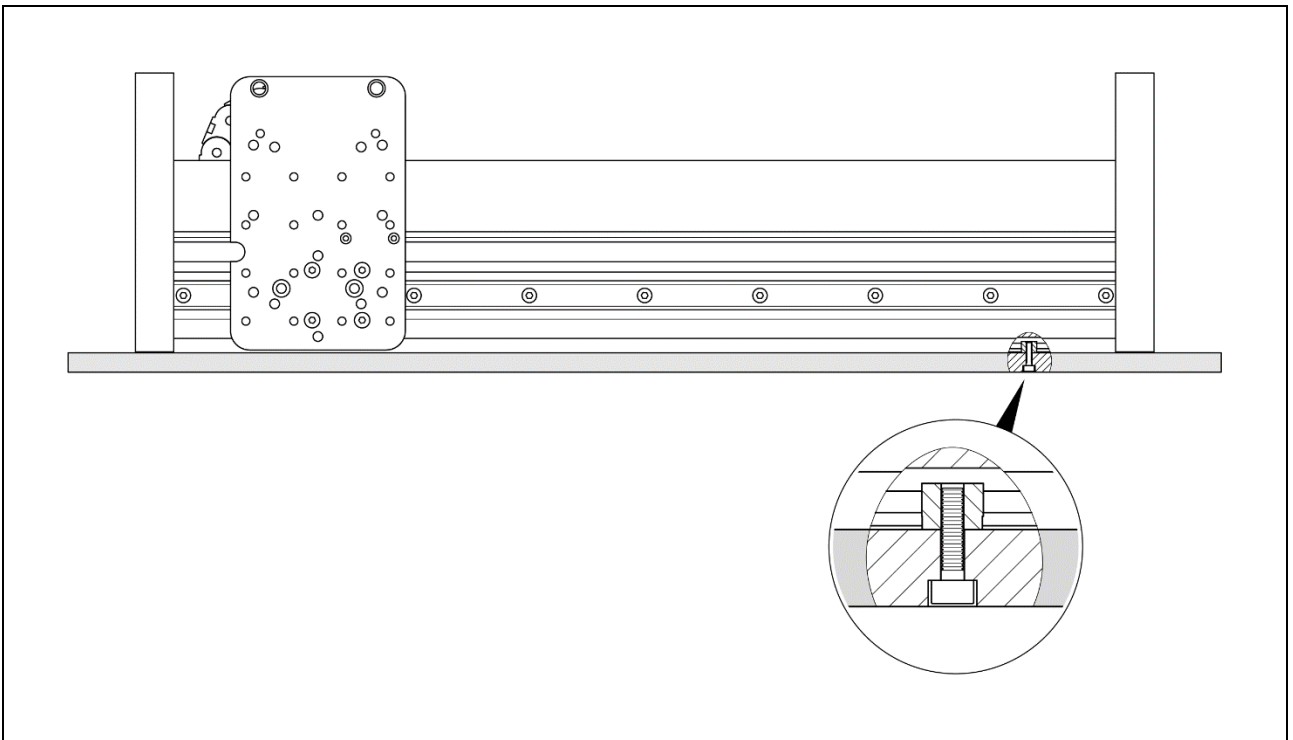

Example 2: Vertical fixing using T-nuts on the underside of the module basis.

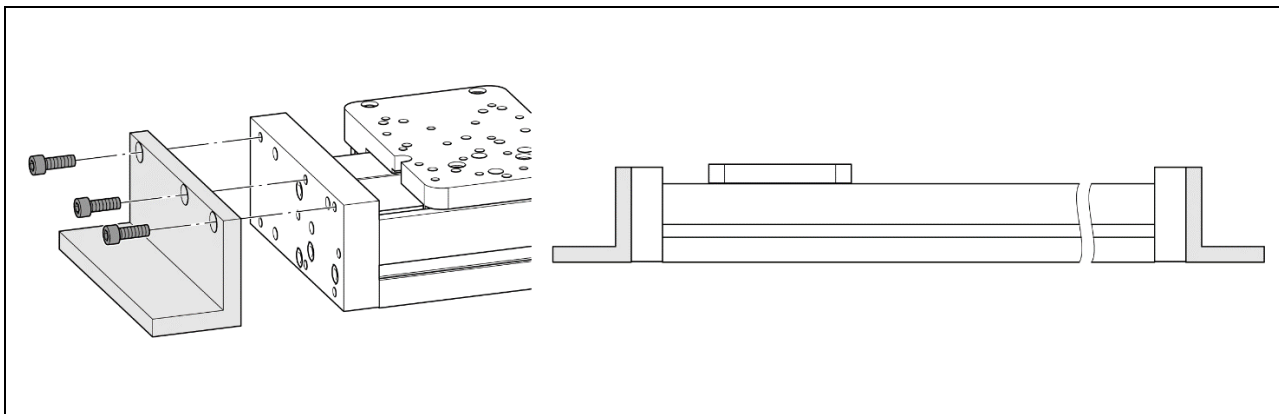

Example 3: Lying attachment with end plates (lengths up to 1200 mm, only with cross table trailing chains).

Ordering information

Item	Description	Item-No.
Nut N8/M4	Nut for 8 mm T-slots with M4 thread	0150-2189
Nut N8/M6	Nut for 8 mm T-slots with M6 thread	0150-2558

4.2 Installation of the load

The carriages of the FM01 linear module have an integrated mounting plate, which is used to attach the load. The mounting plate is equipped with several bores and fittings for parallel pins. The centre of gravity of the load mass should be in the middle and as close as possible to the mounting plate to ensure even distribution of the mass on the carriage.

For example, 16 x M6 through bores are indexed with '0', which can be used for mounting the load. The complete dimensions can be found in chapter 11 "Dimensions and weights".



Before performing installation of the load, all necessary precautions must be taken to prevent operation of this device, e. g. the device must be disconnected from the power supply.

4.2.1 Mounting plate FM01-37S...37Sx60...

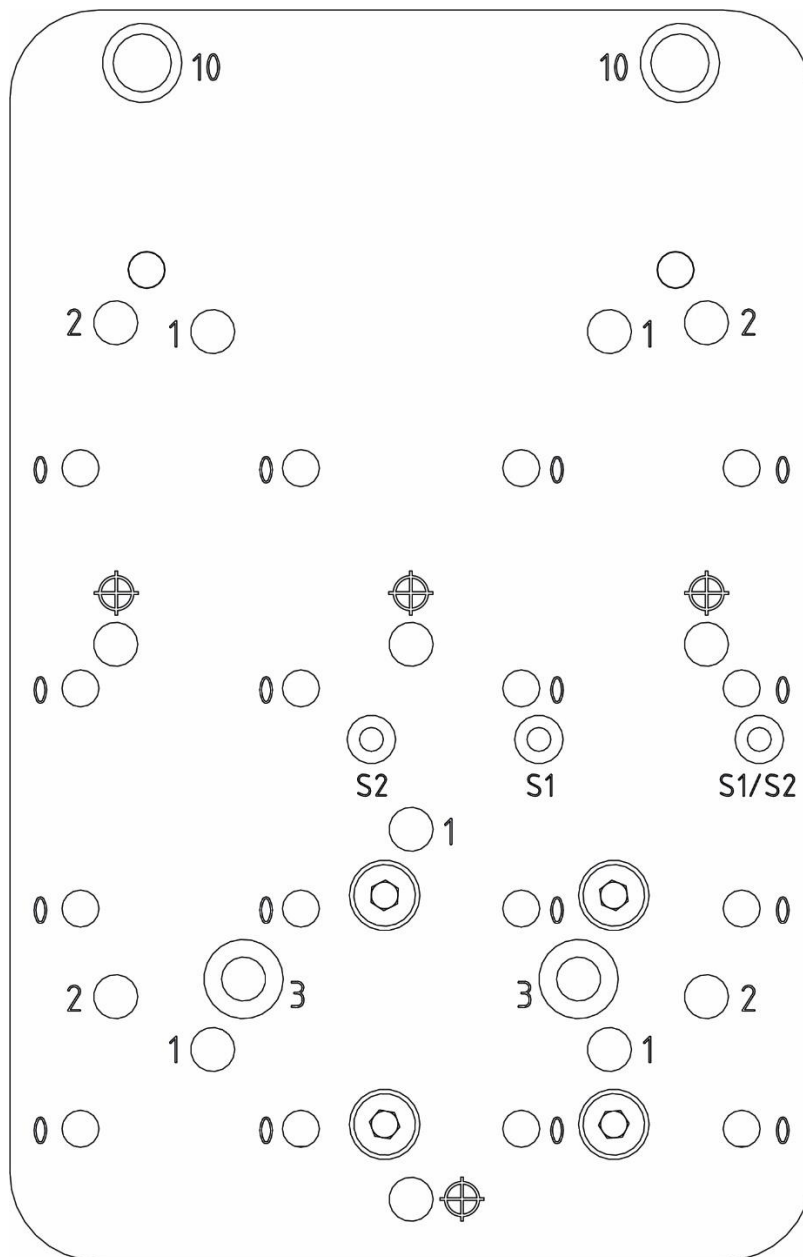

4.2.2 Mounting plate FM01-37S...37Sx120...

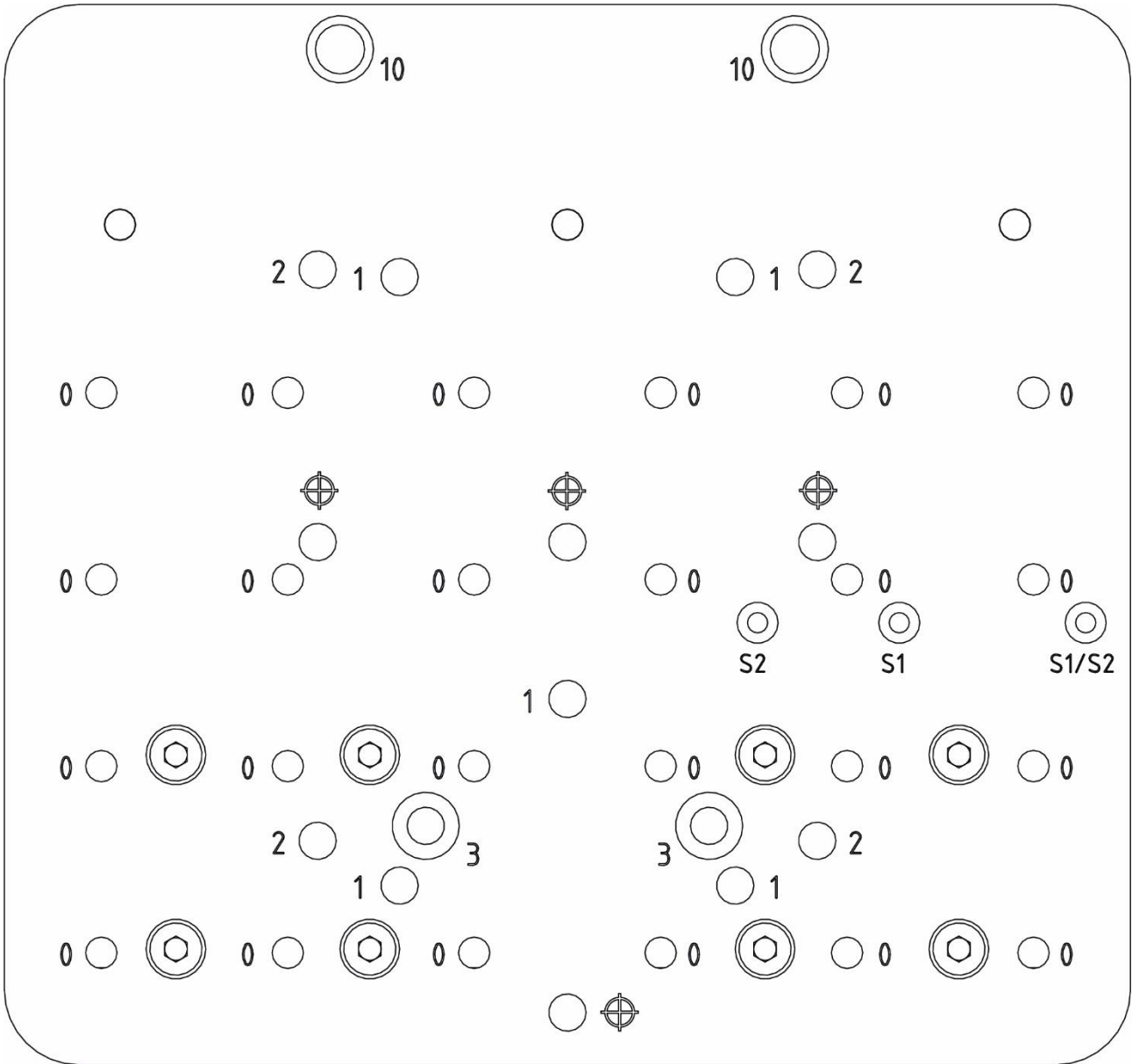

4.3 Cantilever linear modules

Use as a cantilever linear module is made possible by the high rigidity of the profile. The limiting factor for cantilever linear modules is deflection. The allowable deflection depends on, among other things, the load, the dynamics, the mounting position and the support.

4.3.1 Cantilever linear modules with mounting on one side

The installation position influences the deflection. With the same load, the "upright" installation position exhibits less deflection than the "lying" installation position. For this reason, the "upright" installation position is considered below.

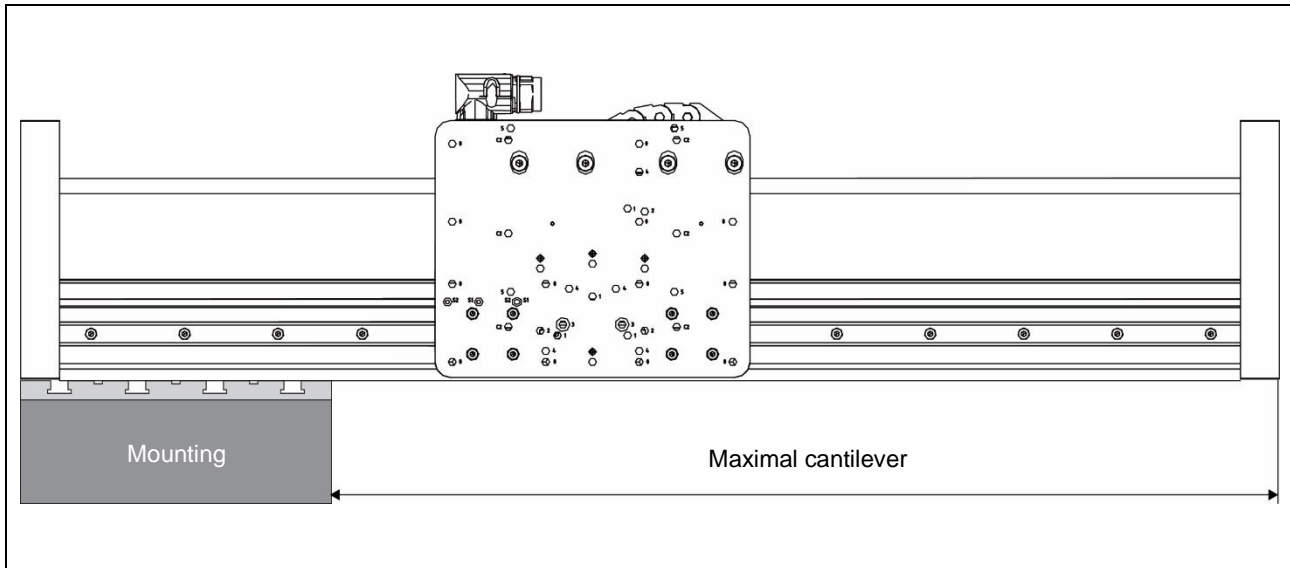

- It is not sufficient to use only the end plate of the linear module for mounting. The mounting must be designed to provide the widest possible support for the linear module.
- As a guide, a cantilever of 500 mm with a load of 15 kg in the centre of the mounting plate is possible without consultation. Cantilevers greater than 500 mm or larger loads are possible but must be checked on a case-by-case basis (support@linmot.com).
- The dynamic design of the module must be checked using the LinMot Designer programme.

4.3.2 Cantilever linear modules with double-sided or multiple mountings

The installation position influences the deflection. With the same load, the "upright" installation position exhibits less deflection than the "lying" installation position. For this reason, the "upright" installation position is considered below.

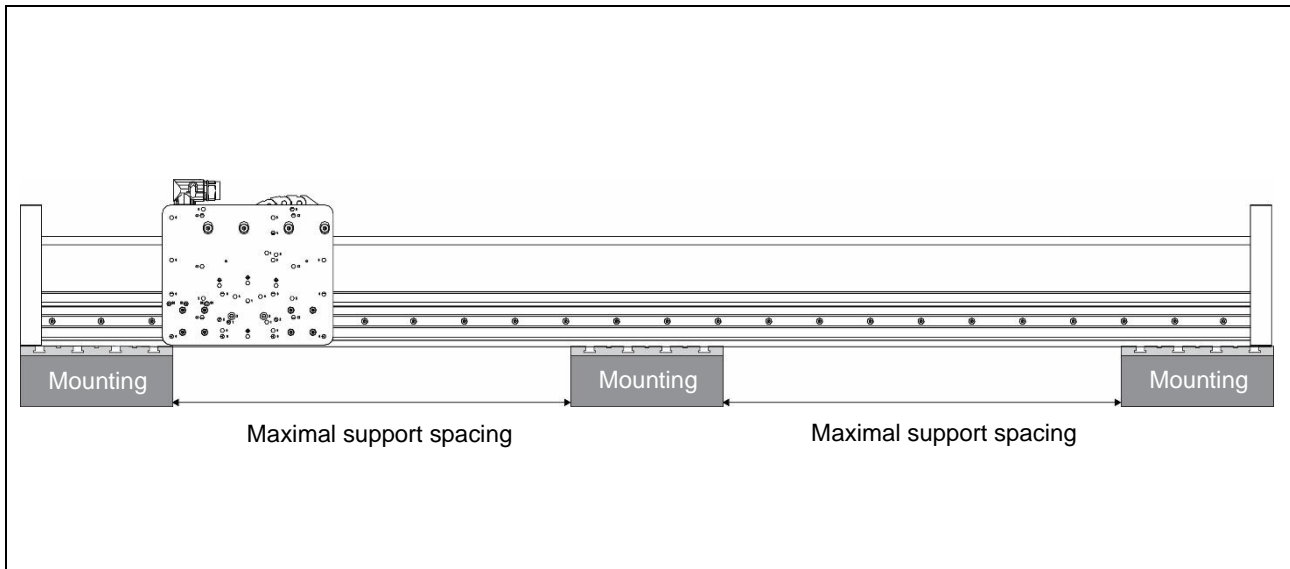

- The mounting must be designed to provide the widest possible support for the linear module.
- As a guideline, cantilever linear modules with a support spacing of 1000 mm and a load mass of 20 kg in the centre of the mounting plate are possible without consultation. Support distances greater than 1000 mm or larger loads are possible but must be checked on a case-by-case basis (support@linmot.com).
- The dynamic design of the module must be checked using the LinMot Designer programme.

5 Electrical Connection



Only connect or disconnect the motor connector and sensor cable if no voltage is applied to the servo drive! Only original LinMot cables may be used for wiring the motor and sensor! Even assembled cables may only be manufactured from the original LinMot accessories and must be checked carefully before commissioning!
 Incorrect motor wiring can damage the motor and/or the servo drive!

5.1 Motor cable

Two types of cables are available for the FM-Modules. For the moving part of the FM-Module, only trailing chain cables are available. The standard motor cable is used as a stationary extension between high-flex cable and drive.

	Standard cable	Trailing chain cable
Cable type	K05	KS05
Min. bending radius stationary	25 mm (1 in)	25 mm (1 in)
Min. bending radius moving	Not suitable for applications with moving motor cable	55 mm (2 in) No torsion
Approval	UL / CSA 300V	UL / CSA 300V
Material wire insulation	TPE-U	TPE-E
Material cable sheath	PUR	PUR
Oil resistance	very good	very good
Chemical resistance (to acids, alkalis, solvents, hydraulic fluid)	good	good
Outdoor durability	very good	very good
Flammability	flame retardant	flame retardant

5.2 N-connector wiring

Connector Type	N-connector	
	PIN	Wire
Phase1+	4	Red
Phase1-	3	Pink
Phase2+	2	Blue
Phase2-	1	Grey
+5V	A	White
GROUND*	B	Inner shield
Sensor Sin	C	Yellow
Sensor Cos	D	Green
Temp sensor	E	Black
SHIELD* of stator and stator cable	Case	
Connector on the stator (-cables)		



Extension cables are double shielded. The two shields of the extension cables must not be connected together: the inner shield of the extension cables is used as GROUND and must be connected to GROUND*; only the outer shield must be connected to SHIELD* of the connector.

6 Start-up



It is recommended to use the newest version of LinMot-Talk software.

You can find more detailed information about LinMot-Talk software in LinMot Talk User Manual that can be downloaded on www.linmot.com.

6.1 LinMot drive setup

The various parameters for the linear motor are set on the drive side using the corresponding motor wizard in the LinMot Talk configuration software. Each stator is electrically independent unit and if multiple stators are used on the same guide a specific commissioning order is not required.

6.2 Standard values of the coordinate system / standard installation stator

The positive direction of motion of the carriage is defined from left to right by default. This can be changed with the LinMot-Talk (Motor Wizard) software. Please note that the direction specifications "right", "left" and "centre" are always to be understood from the front of the module (see illustration).

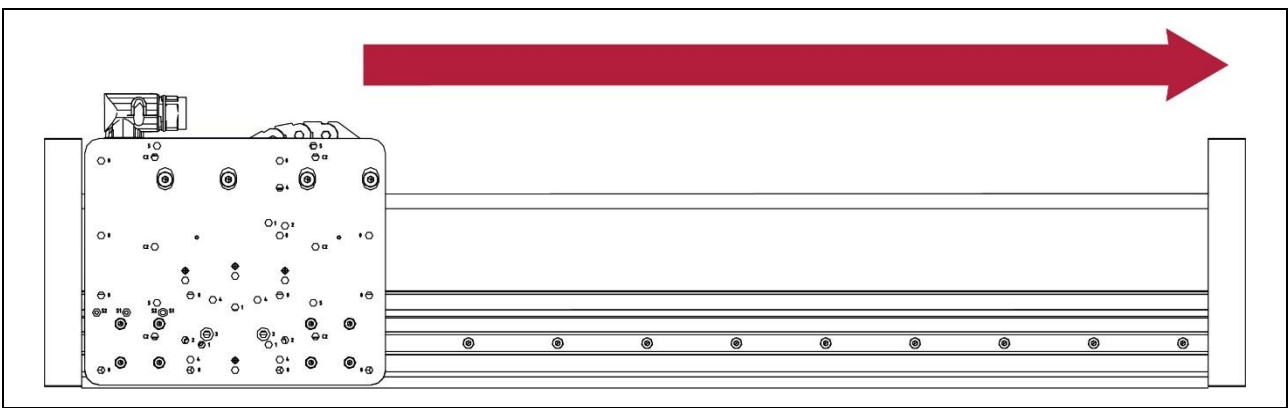

- The carriage (and the stator installed in it) always points in the same direction. Under no circumstances may it be installed rotated by 180°.
- The position (angle of rotation) of the rotor is marked by a notch in the front plate. It must not be installed twisted under any circumstances.

6.3 Setting the Parameters

Logged into the drive, you will find all the parameters to be set in the LinMot-Talk's software motor wizard. You can find the necessary information such as moving mass and friction of the carriage kits in the chapter "Technical data carriage kits".

Proceed through wizard step-by-step following more detailed instructions in LinMot-Talk user manual, which can be downloaded from www.linmot.com.

6.3.1 Defining Payload

Together with the moving masses, the mass of the load must be counted in. In some applications, the mass of the cables must be considered.

6.3.2 PID Controller

Recommended values are higher than default values in the LinMot talk wizard. By heavier payload, increase the values if needed.

6.3.3 Achieving Full Stroke Length

To use the full mechanical stroke, it is necessary to change "Minimal Position" and "Maximal Position" values in Position Limits tab. These can be found under Motion Control SW. Alternatively, you can disable the "Maximal Position" detection in the Error Detection Mask.

6.4 Master-slave configuration

In gantry designs, the master-slave configuration is recommended on motors with parallel axes, that are moving the middle-axis. Refer to MasterSlave Application user manual for detailed instructions and supported drives.

7 Accessories

7.1 Trailing chain kits



Item	Description	Item-No.
F01-TC300-37	Trailing chain kit for FM01-37 (Art-Nr. 0150-4980, 0150-4990)	0150-5457
F01-TC400-37	Trailing chain kit for FM01-37 (Art-Nr. 0150-4988, 0150-4947)	0150-5456
F01-TC500-37	Trailing chain kit for FM01-37 (Art-Nr. 0150-4989, 0150-4948)	0150-5455
F01-TC600-37	Trailing chain kit for FM01-37 (Art-Nr. 0150-4991, 0150-4949)	0150-5439
F01-TC800-37	Trailing chain kit for FM01-37 (Art-Nr. 0150-4992, 0150-4981)	0150-5440
F01-TC1000-37	Trailing chain kit for FM01-37 (Art-Nr. 0150-4993, 0150-4982)	0150-5441
F01-TC1200-37	Trailing chain kit for FM01-37 (Art-Nr. 0150-4994, 0150-4983)	0150-5442
F01-TC1400-37	Trailing chain kit for FM01-37 (Art-Nr. 0150-4995, 0150-4984)	0150-5443
F01-TC1600-37	Trailing chain kit for FM01-37 (Art-Nr. 0150-4996, 0150-4985)	0150-5444
F01-TC2000-37	Trailing chain kit for FM01-37 (Art-Nr. 0150-4997, 0150-4986)	0150-5445

7.1.1 Dimensions

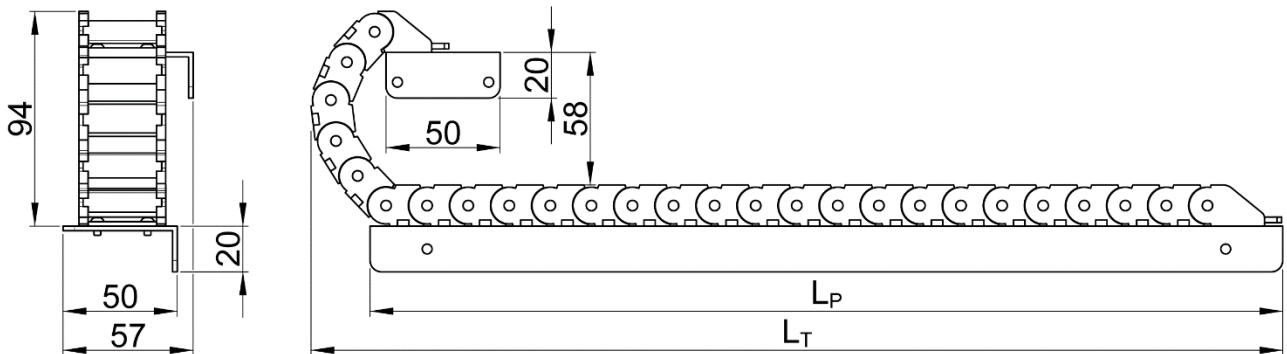

Item	Item-No.	Assumed trailing chain radius R [mm (inch)]	Lower angled-plate length L_P [mm (inch)]	Trailing chain kit total length L_T [mm (inch)]
F01-TC300-37	0150-5457	55 (2.17)	250 (9.84)	300 (11.81)
F01-TC400-37	0150-5456	55 (2.17)	250 (9.84)	400 (15.75)
F01-TC500-37	0150-5455	55 (2.17)	250 (9.84)	500 (19.69)
F01-TC600-37	0150-5439	55 (2.17)	300 (11.81)	600 (23.62)
F01-TC800-37	0150-5440	55 (2.17)	400 (15.75)	800 (31.50)
F01-TC1000-37	0150-5441	55 (2.17)	500 (19.69)	1000 (39.37)
F01-TC1200-37	0150-5442	55 (2.17)	500 (19.69)	1200 (47.24)
F01-TC1400-37	0150-5443	55 (2.17)	700 (27.56)	1400 (55.12)
F01-TC1600-37	0150-5444	55 (2.17)	800 (31.50)	1600 (63.00)
F01-TC2000-37	0150-5445	55 (2.17)	1000 (39.37)	2000 (78.74)

7.1.2 Overview trailing chain kit

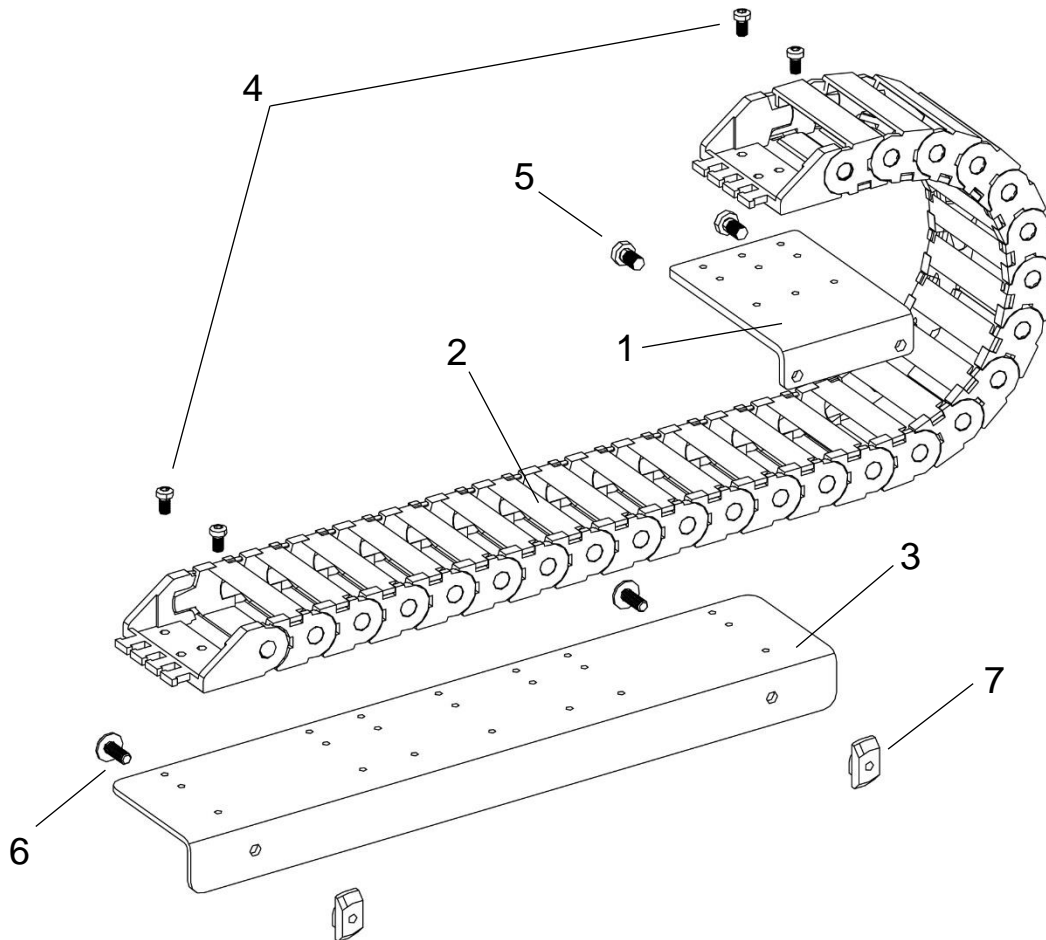

Pos.	Item
1	Trailing chain angle plate
2	Trailing chain
3	Trailing chain L-Profile
4	Socket pan head screws ISO14583 M3x6
5	Socket pan head screws ISO14583 M4x10
6	Socket pan head screws ISO14583 M4x10
7	Nut N8/M4

7.2 Assembly of the trailing chains

There are various possibilities for mounting the trailing chains, depending on the type of installation of the module and the number of carriages.



- Please note that the installation must always be carried out according to the ordered installation variant (e.g.: 0140-0051 cable connector bottom right).
- Please note that the directions "right", "left" and "centre" are always to be understood from the front of the module.

Mounting variants for one carriage:

Standard: 0140-0050 option (default): Cable connector bottom left

The cable is routed towards the left-hand end plate.

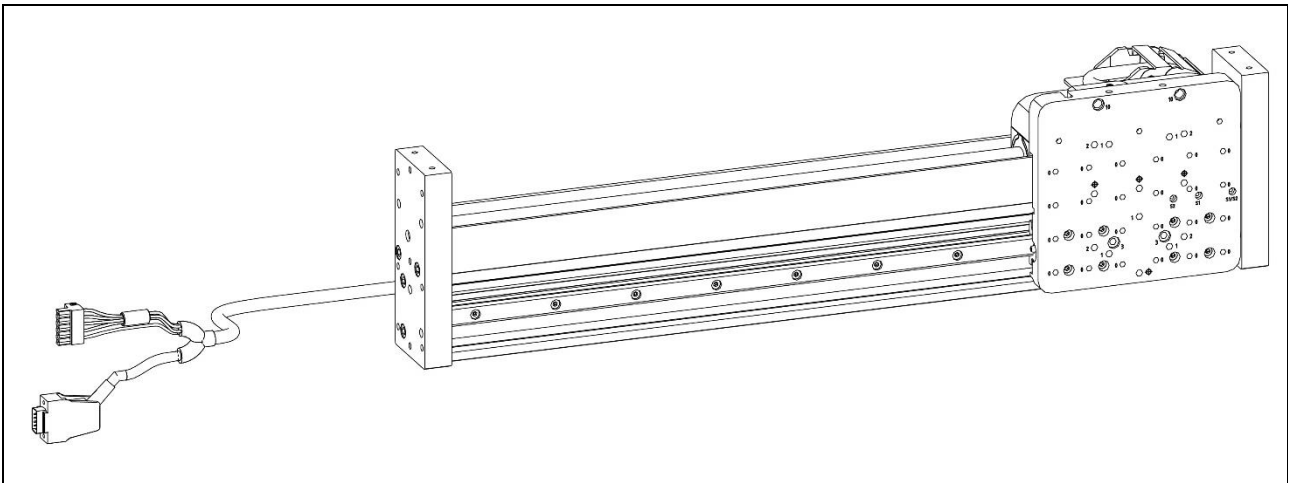

Inverted: 0140-0051 option: Cable connector bottom right

The cable is routed towards the right-hand end plate.

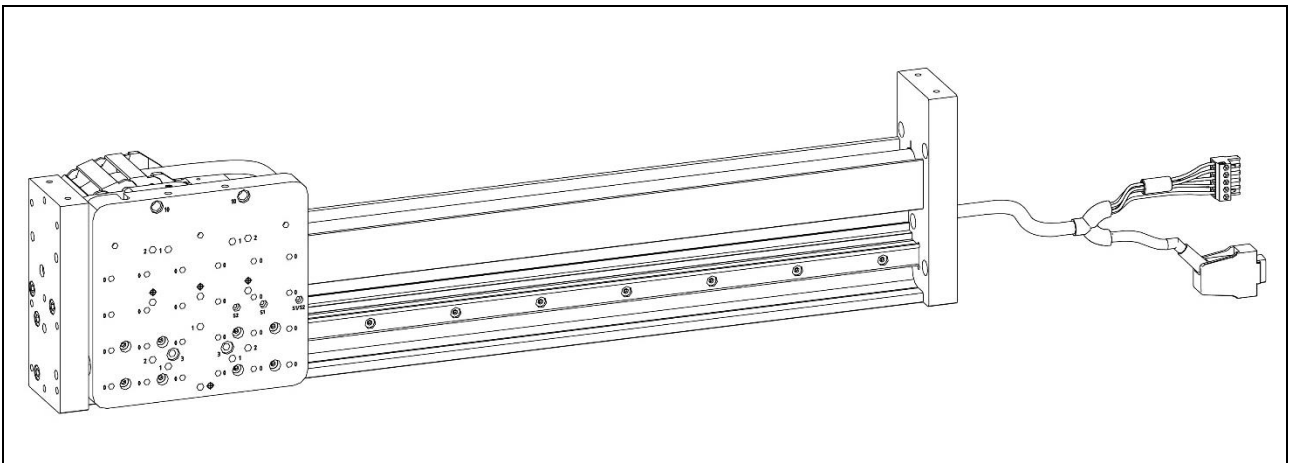

Mounting variants for two carriages

Cable exit on the centre: 0140-0052 option (default): Cable connector bottom centre

The cables are routed to the centre of the module.

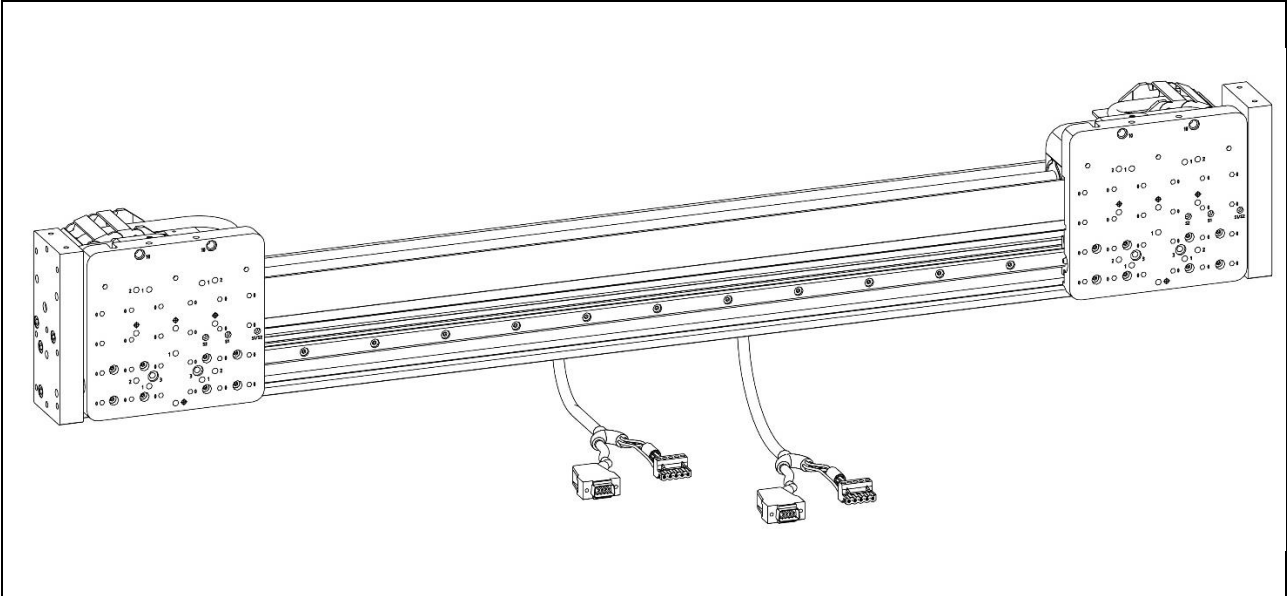

Cable exit on the sides: 0140-0053 option: Cable connector bottom left/right

The cable of the left carriage is routed towards the left end plate, the cable of the right carriage towards the right end plate.

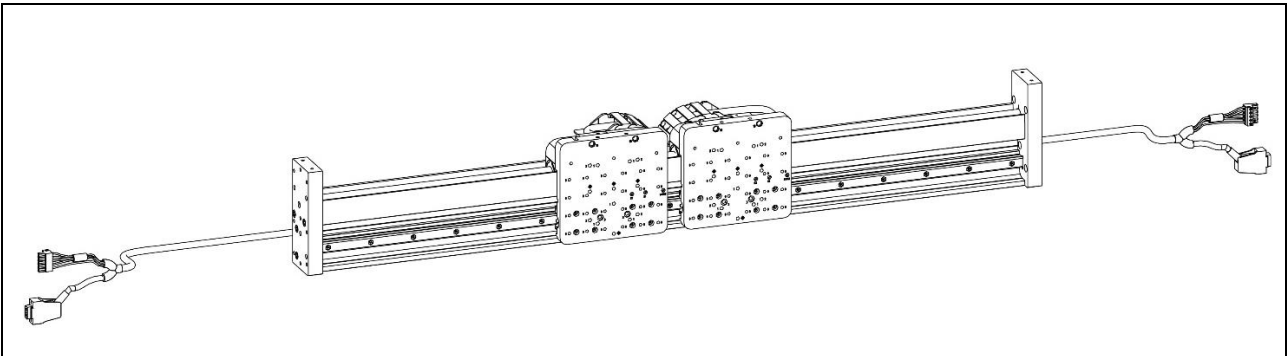

Cable exit left/centre: 0140-0054 option: Cable connector bottom left/centre.

The cable of the left carriage is routed towards the left end plate, the cable of the right carriage towards the centre of the module.

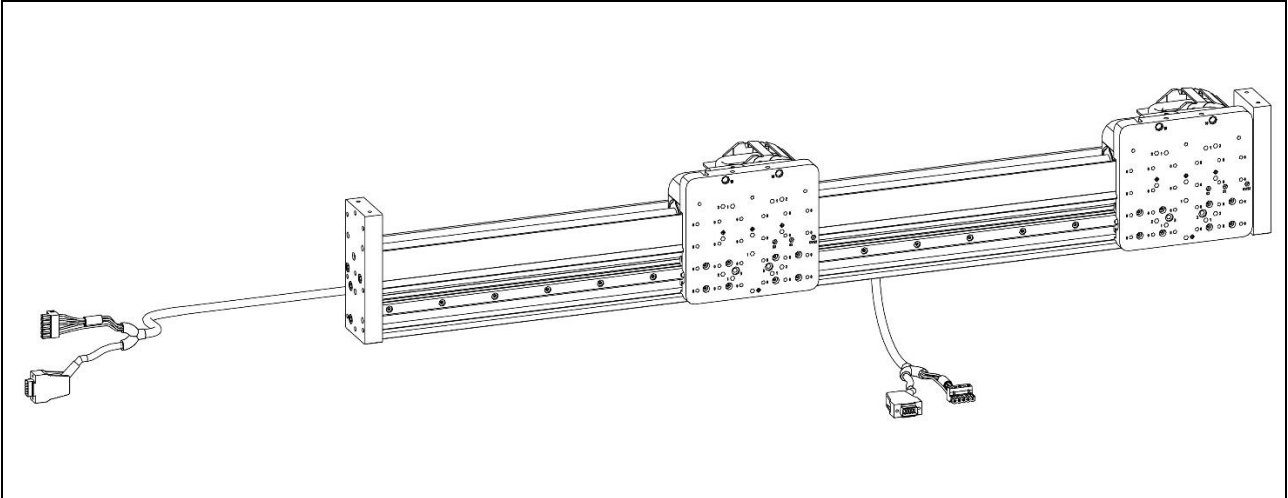

Cable exit centre/right: 0140-0055 option: Cable connector bottom centre/right.

The cable of the left carriage is routed towards the centre of the module, the cable of the right carriage towards the right end plate.

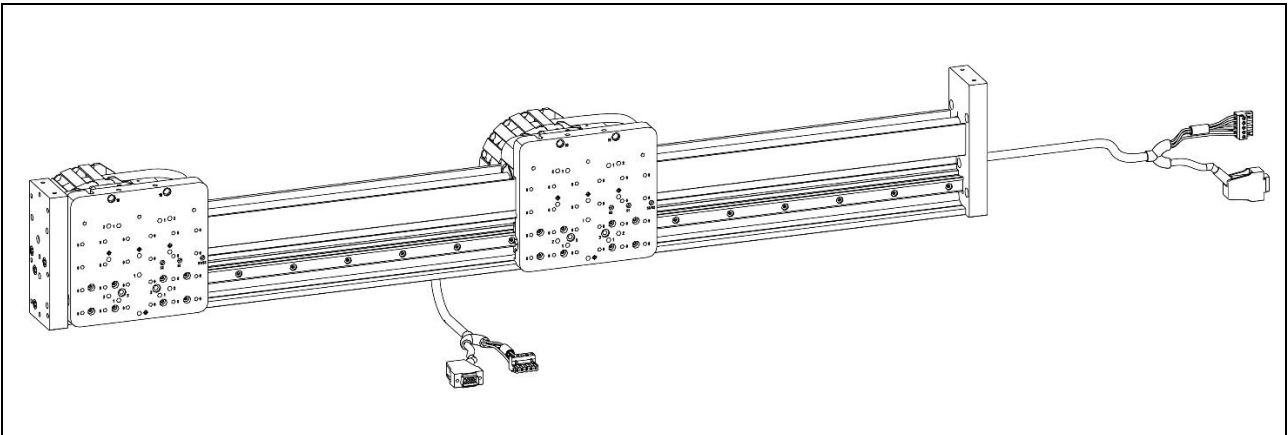

7.2.1 Standard installation of the trailing chain on one carriage (0140-0050 option (default): Cable connector bottom left)

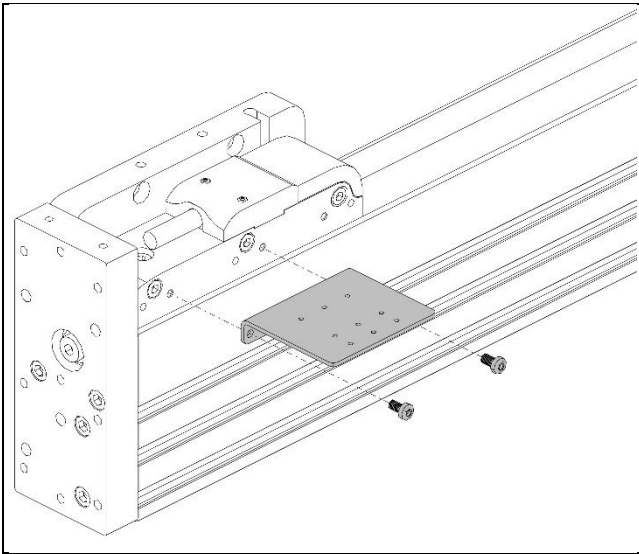

1. Mount the angle plate on the carriage. Use screw locking compound.

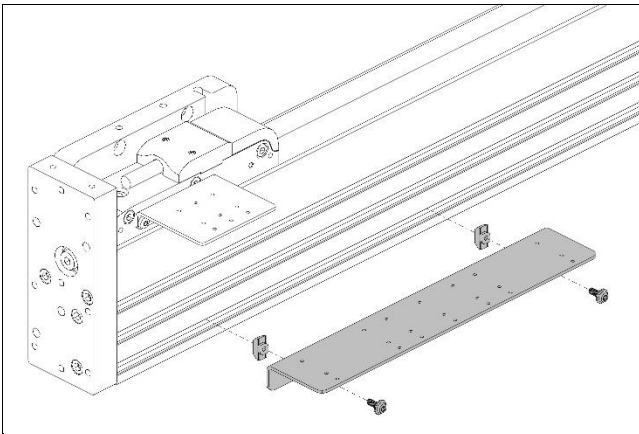

2. Mount the lower angle plate with T-nuts in the lower part of the module base. Longer lower angle plates have an additional fixing point in the centre.

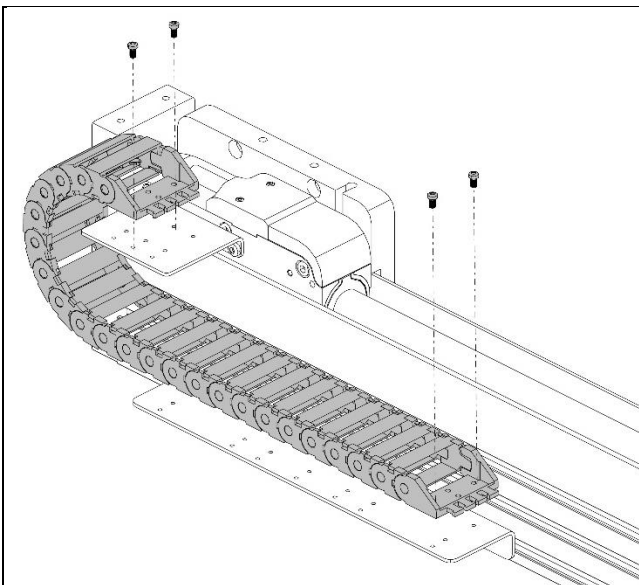

3. Insert the cable into the trailing chain and fit the trailing chain to the plates. Use screw locking compound.

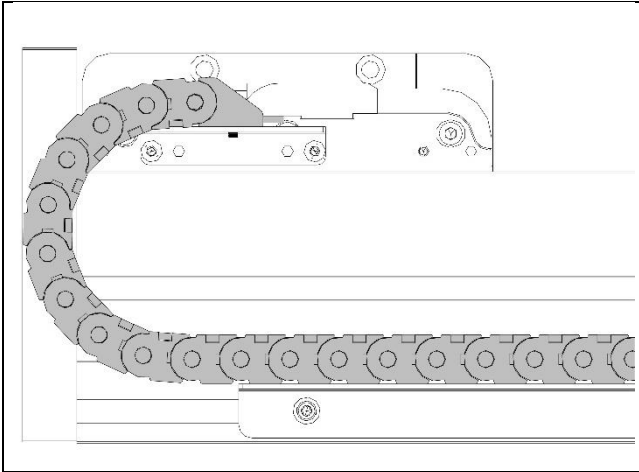

4. Align the lower angle plate so that the trailing chain with cable does not protrude from the module and the permissible cable bending radius is maintained. The carriage must be able to achieve the full required mechanical stroke.

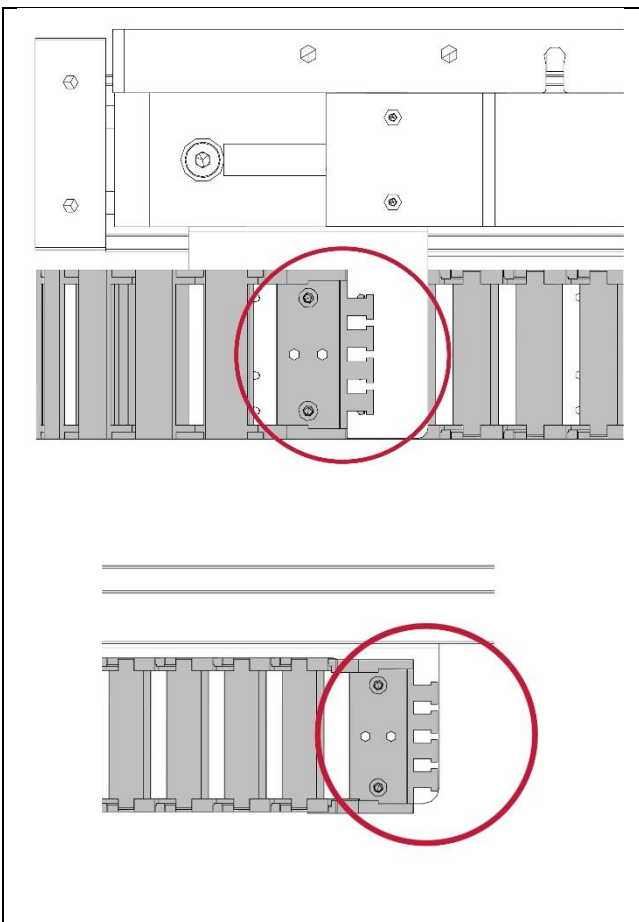

5. Fix the cable to the trailing chain on both sides with cable ties.

7.2.2 Inverted installation of the trailing chain on one carriage (0140-0051 option: Cable connector bottom right)

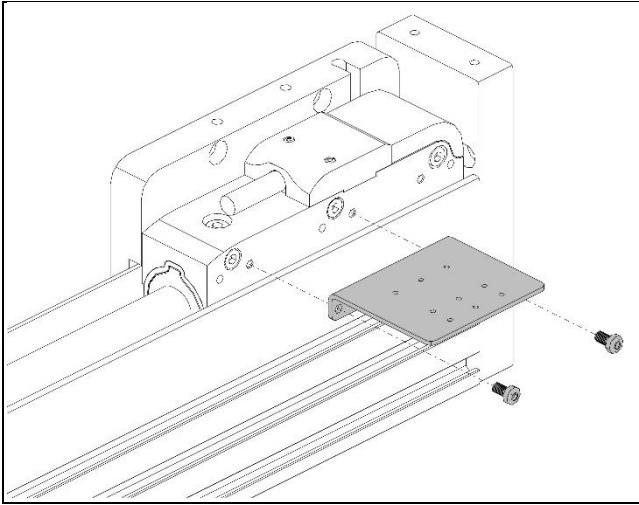

1. Mount the angle plate on the carriage. Use screw locking compound.

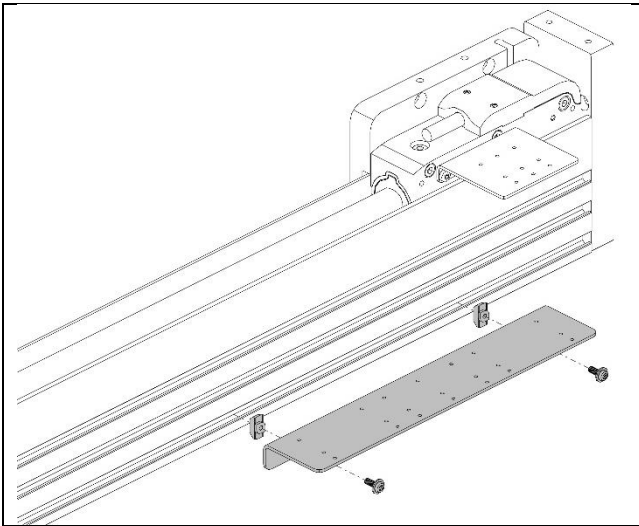

2. Mount the lower angle plate with T-nuts in the lower part of the module base. Longer lower angle plates have an additional fixing point in the centre.

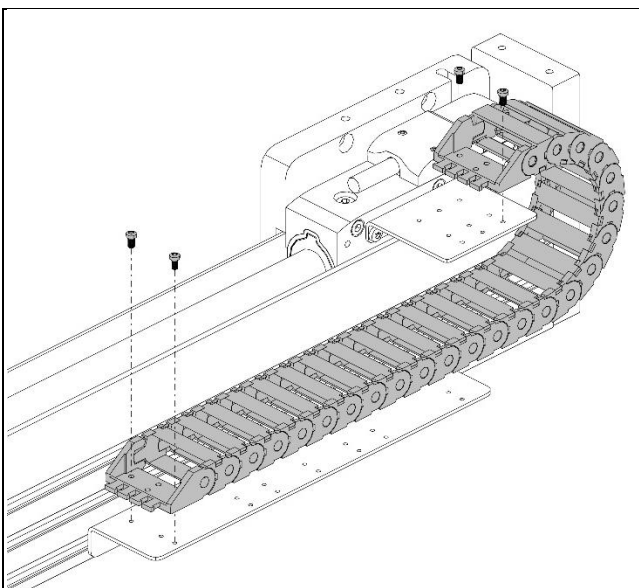

3. Insert the cable into the trailing chain and fit the trailing chain to the plates. Use screw locking compound.

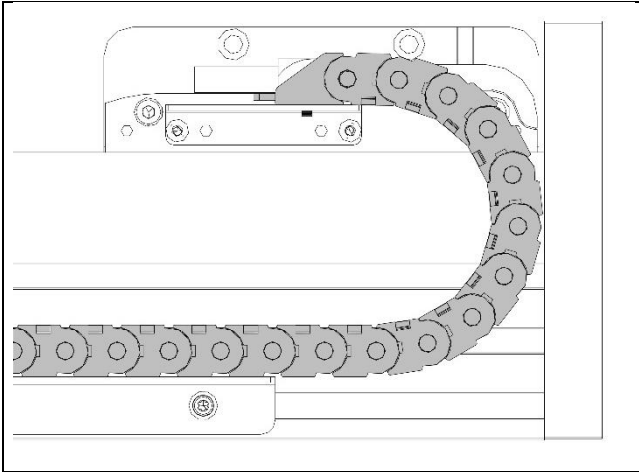

4. Align the lower angle plate so that the trailing chain with cable does not protrude from the module and the permissible cable bending radius is maintained. The carriage must be able to achieve the full required mechanical stroke.

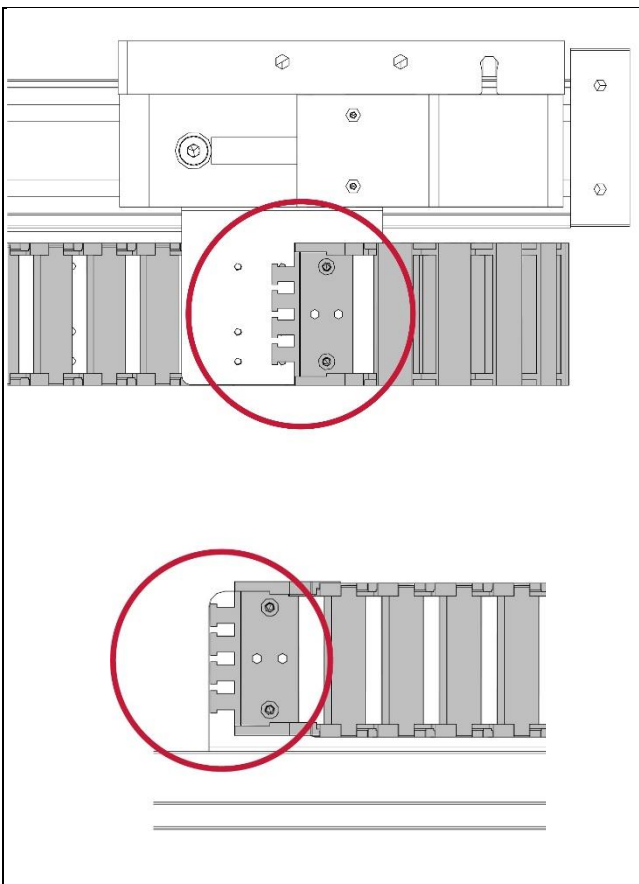

5. Fix the cable to the trailing chain on both sides with cable ties.

7.2.3 Cable exit on the centre with two carriages (0140-0052 option (default): Cable connector bottom center)

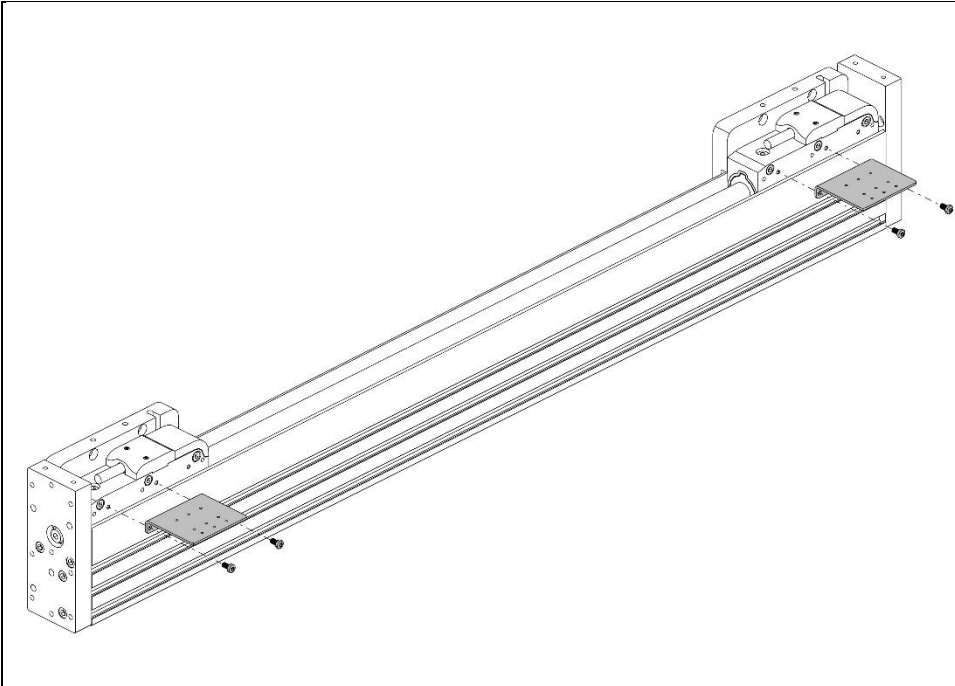

1. Mount the angle plates on the carriages. Use screw locking compound.

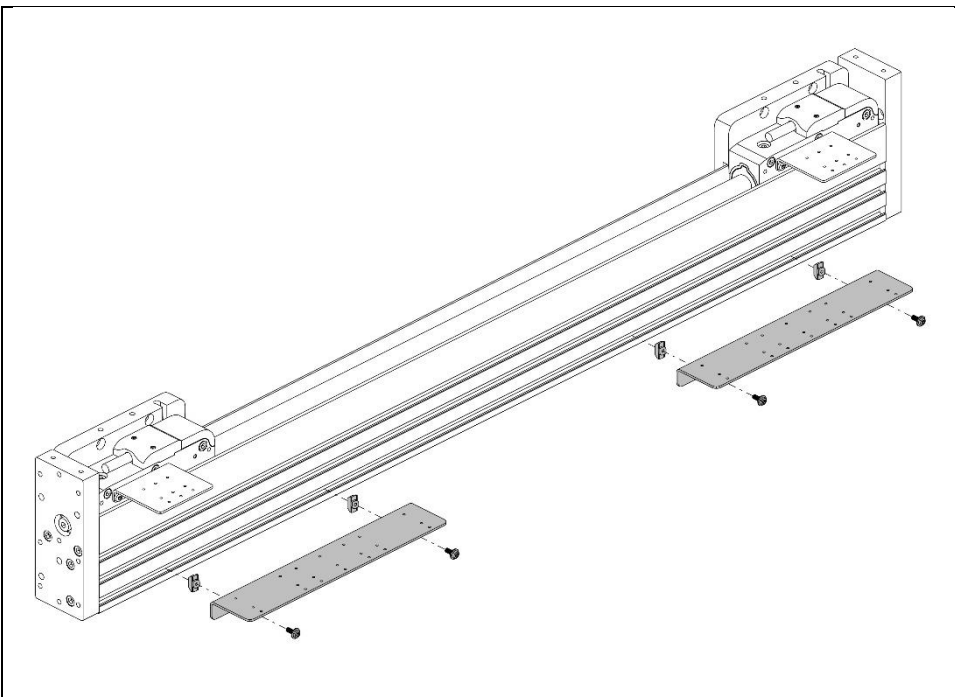

2. Mount the lower angle plates with T-nuts in the lower part of the module base. Longer lower angle plates have an additional fixing point in the centre.

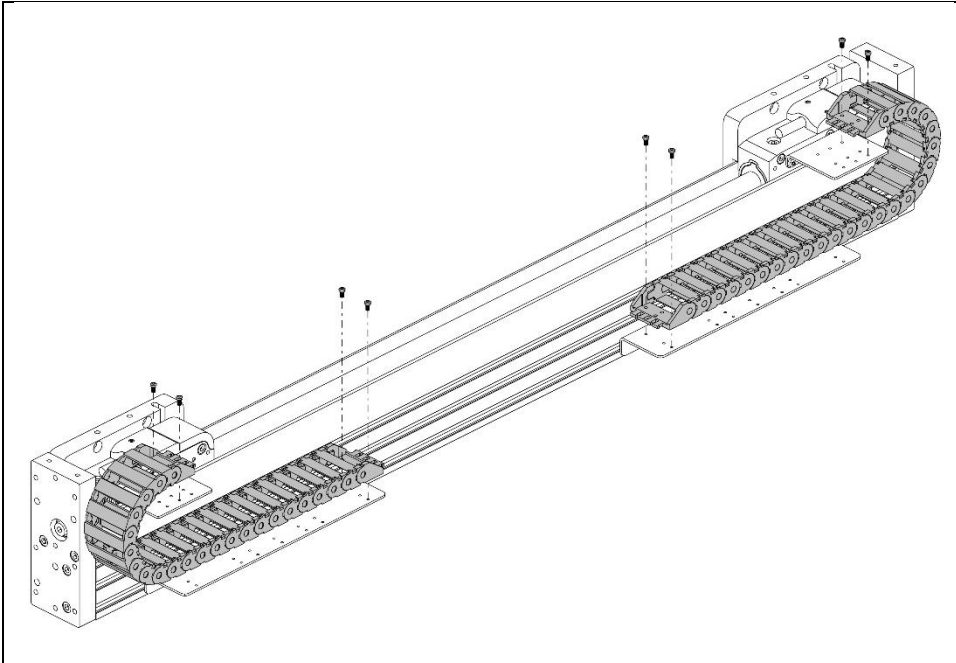

3. Insert the cables into the trailing chains and fit the trailing chains to the plates. Use screw locking compound.

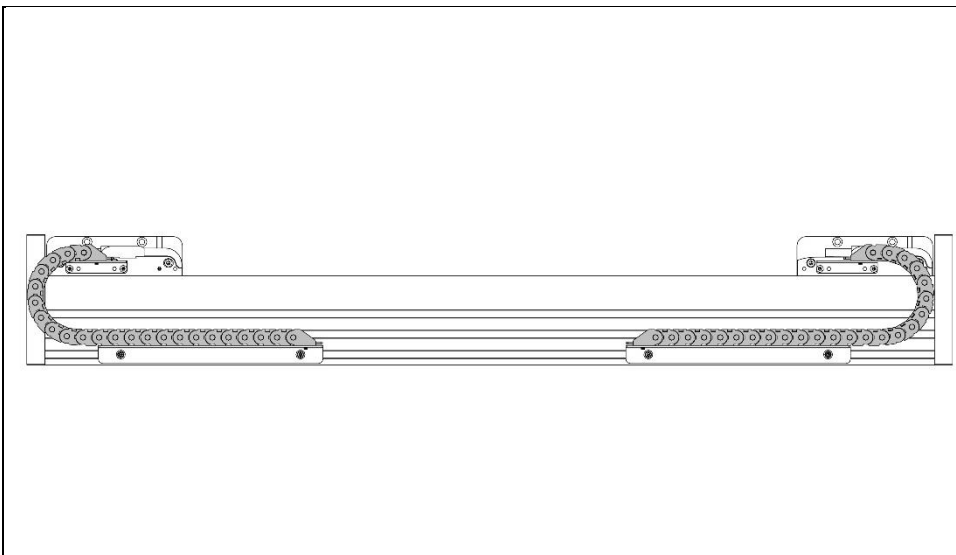

4. Align the lower angle plates so that the trailing chains with cable does not protrude from the module and the permissible cable bending radius is maintained. The carriages must be able to achieve the full required mechanical stroke.

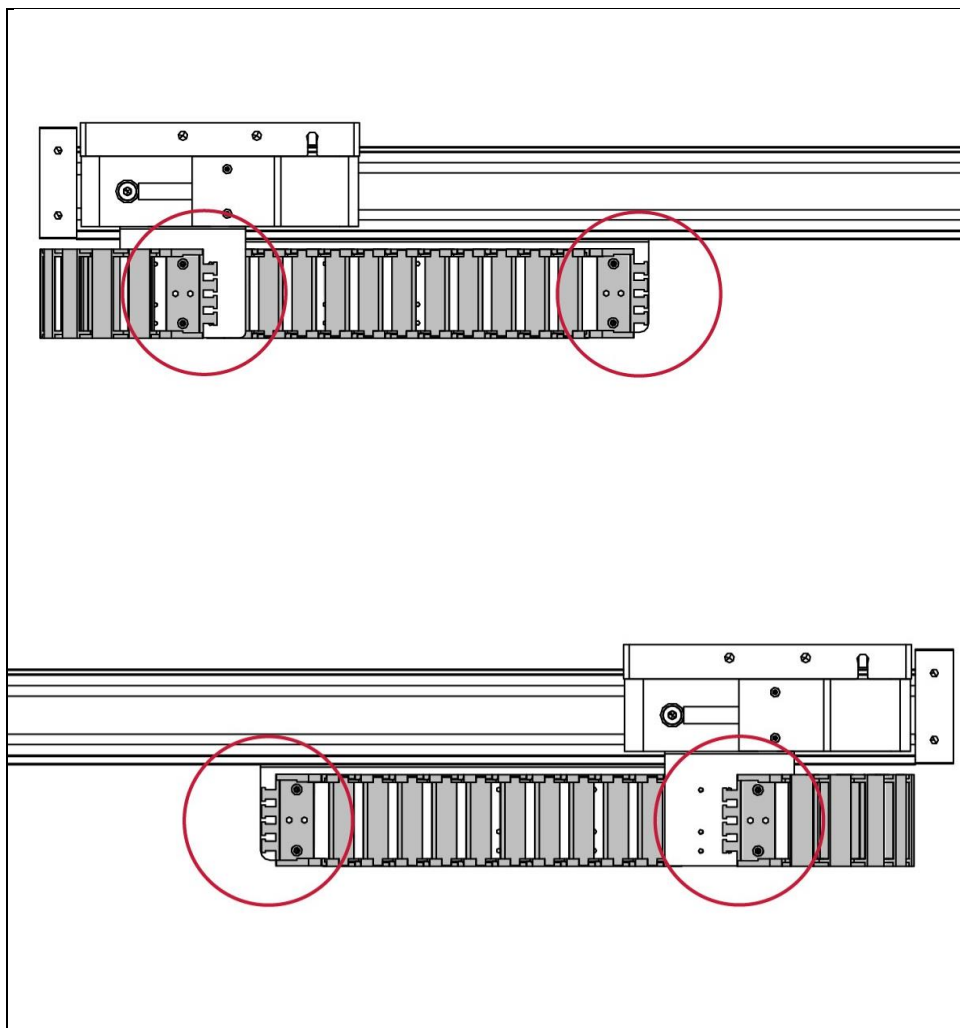

5. Fix the cables to the trailing chains on both sides with cable ties.

7.2.4 Cable exit on the sides with two carriages (0140-0053 option: Cable connector left/right)

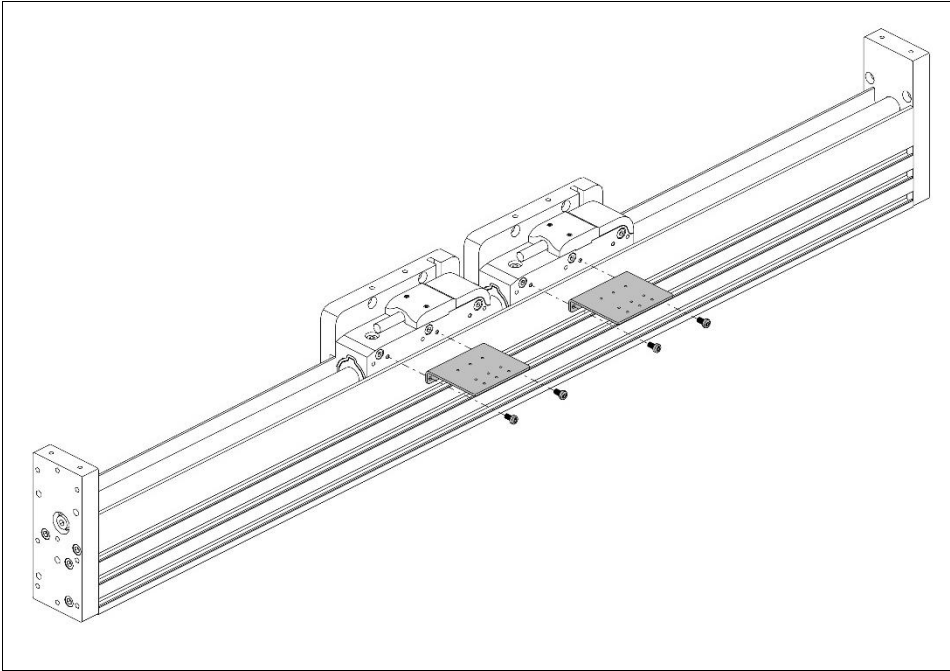

1. Mount the angle plates on the carriages. Use screw locking compound.

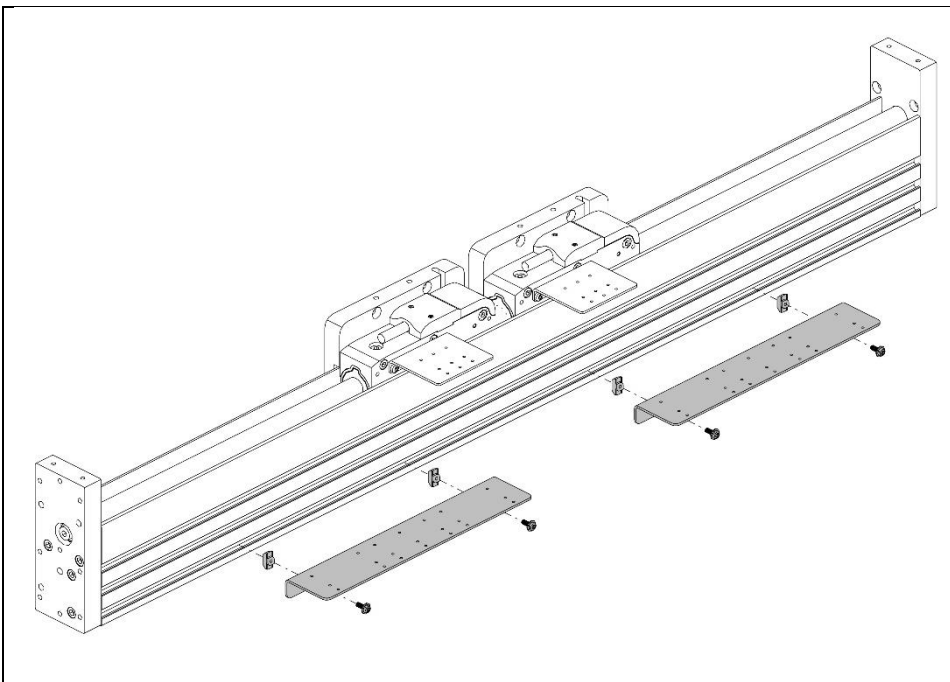

2. Mount the lower angle plates with T-nuts in the lower part of the module base. Longer lower angle plates have an additional fixing point in the centre.

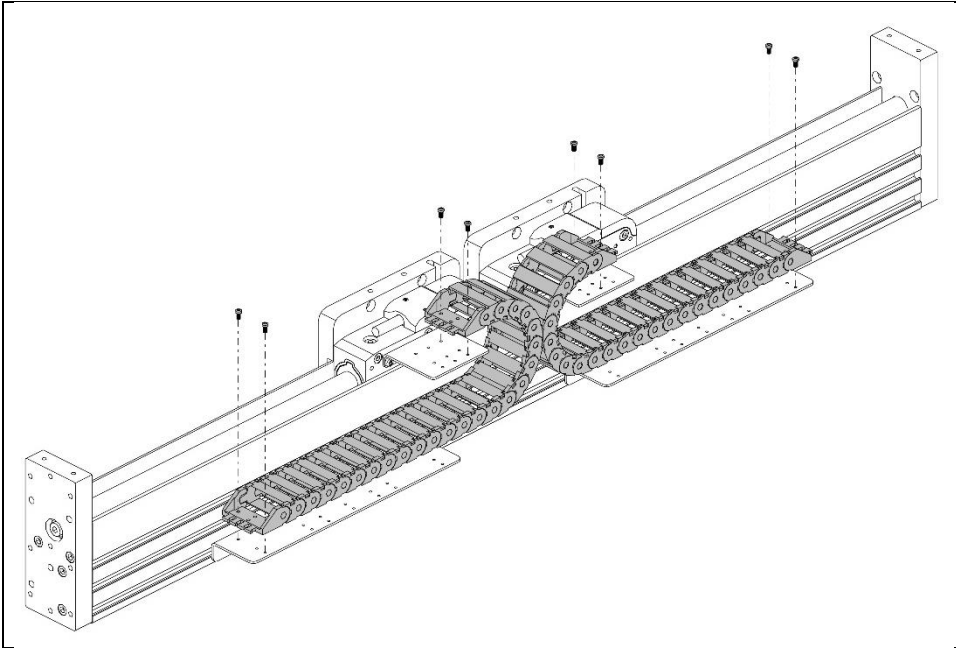

3. Insert the cables into the trailing chains and fit the trailing chains to the plates. Use screw locking compound.

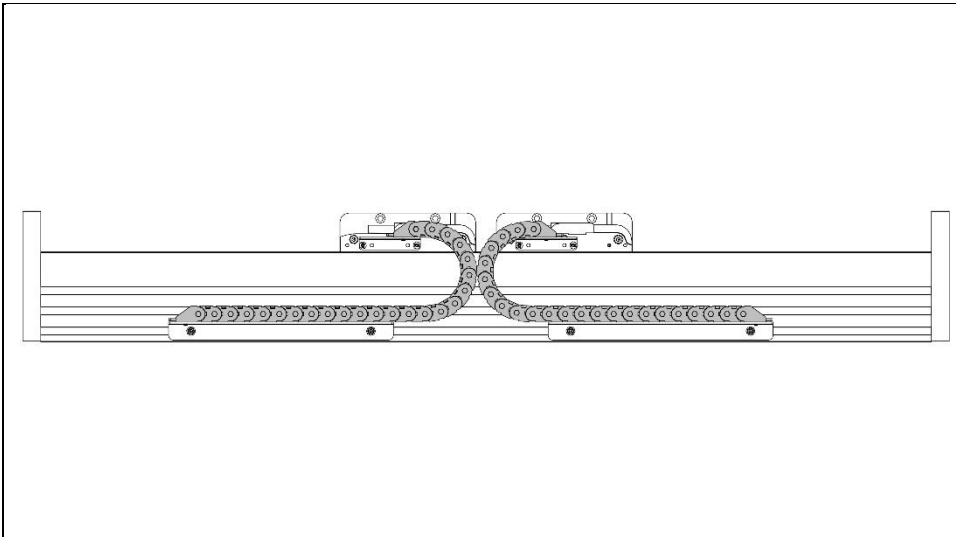

4. Align the lower angle plates so that the trailing chains with cable do not collide and the permissible cable bending radius is maintained. The carriages must be able to achieve the full required mechanical stroke.

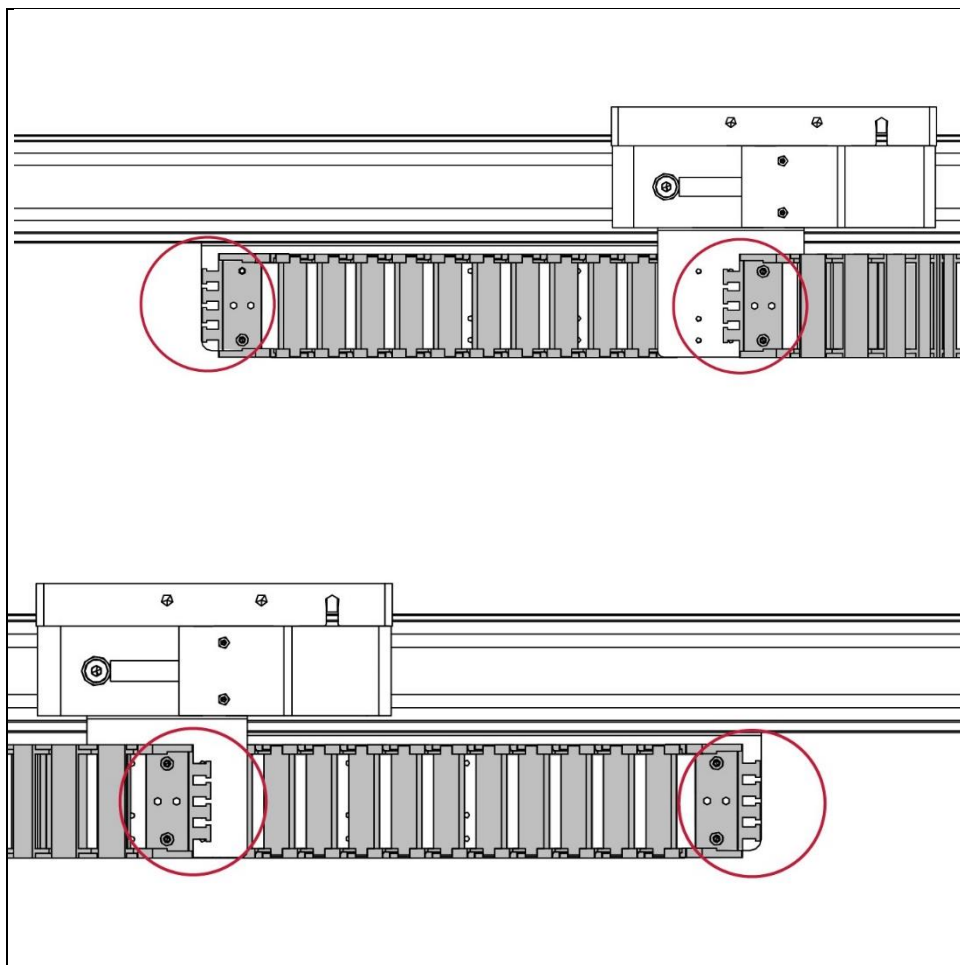

5. Fix the cables to the trailing chains on both sides with cable ties.

7.2.5 Cable exit left/centre with two carriages (0140-0054 option: Cable connector bottom left/centre)

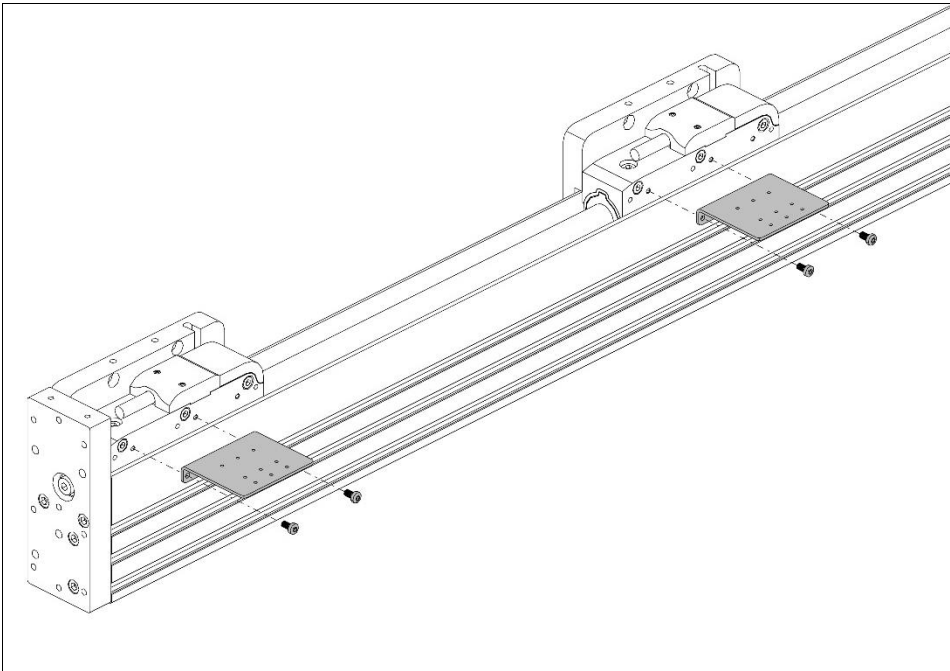

1. Mount the angle plates on the carriages. Use screw locking compound.

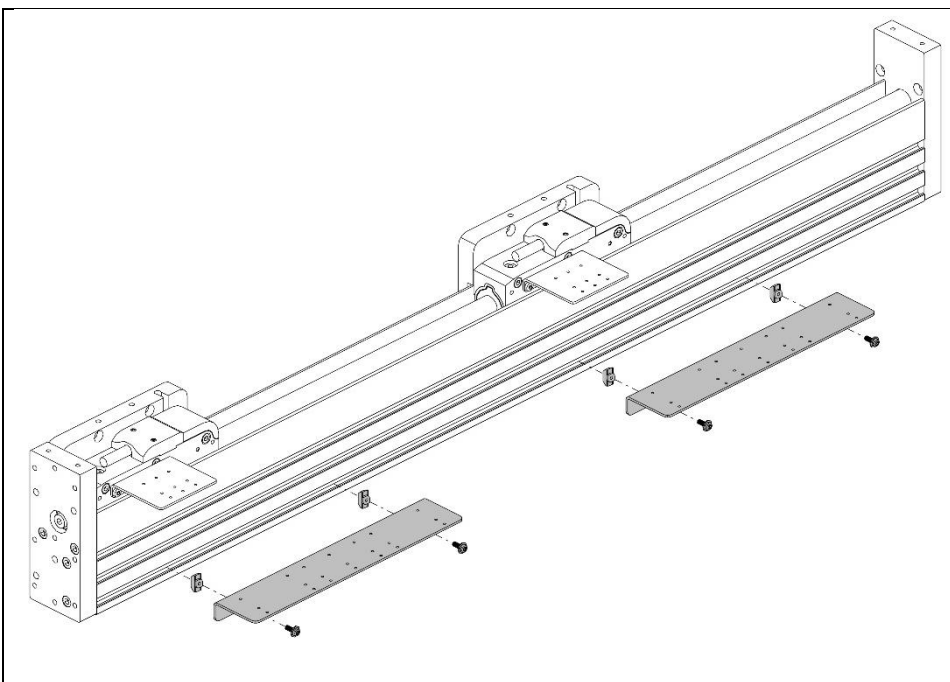

2. Mount the lower angle plates with T-nuts in the lower part of the module base. Longer lower angle plates have an additional fixing point in the centre.

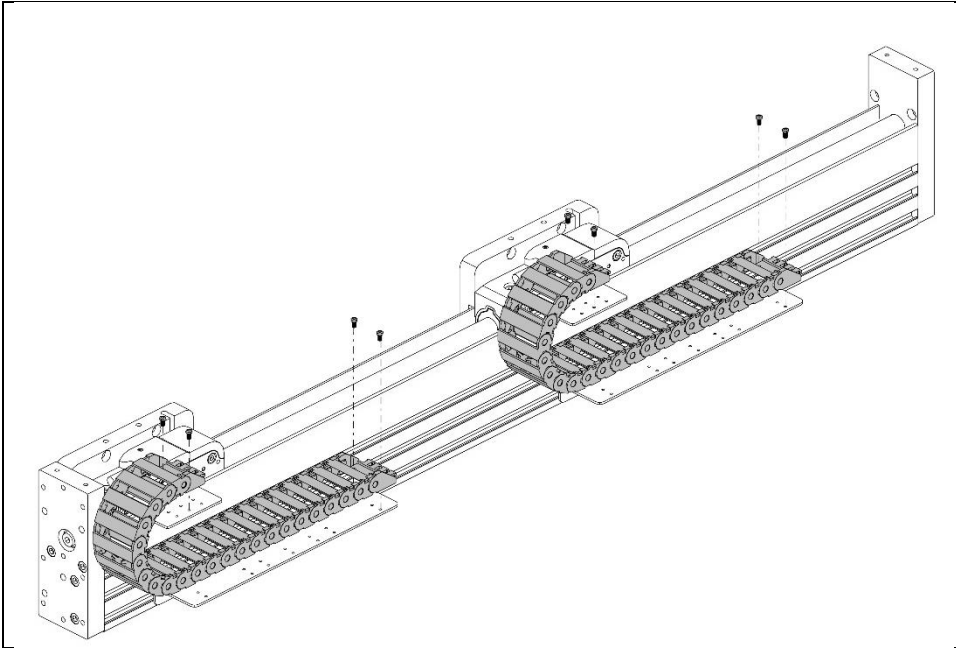

3. Insert the cables into the trailing chains and fit the trailing chains to the plates. Use screw locking compound.

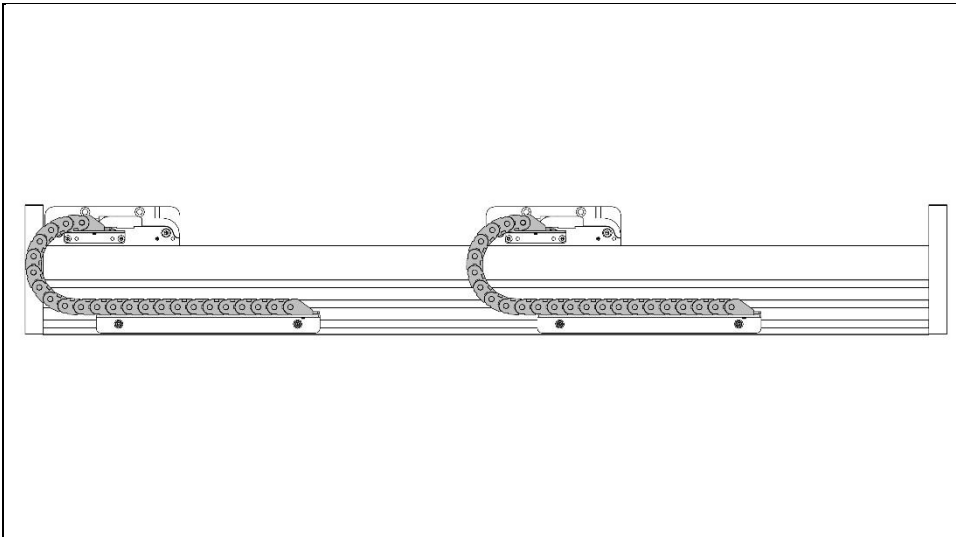

4. Align the lower angle plates so that the trailing chain (here on the left) with cable does not protrude from the module and the permissible cable bending radius is maintained. The carriages must be able to achieve the full required mechanical stroke.

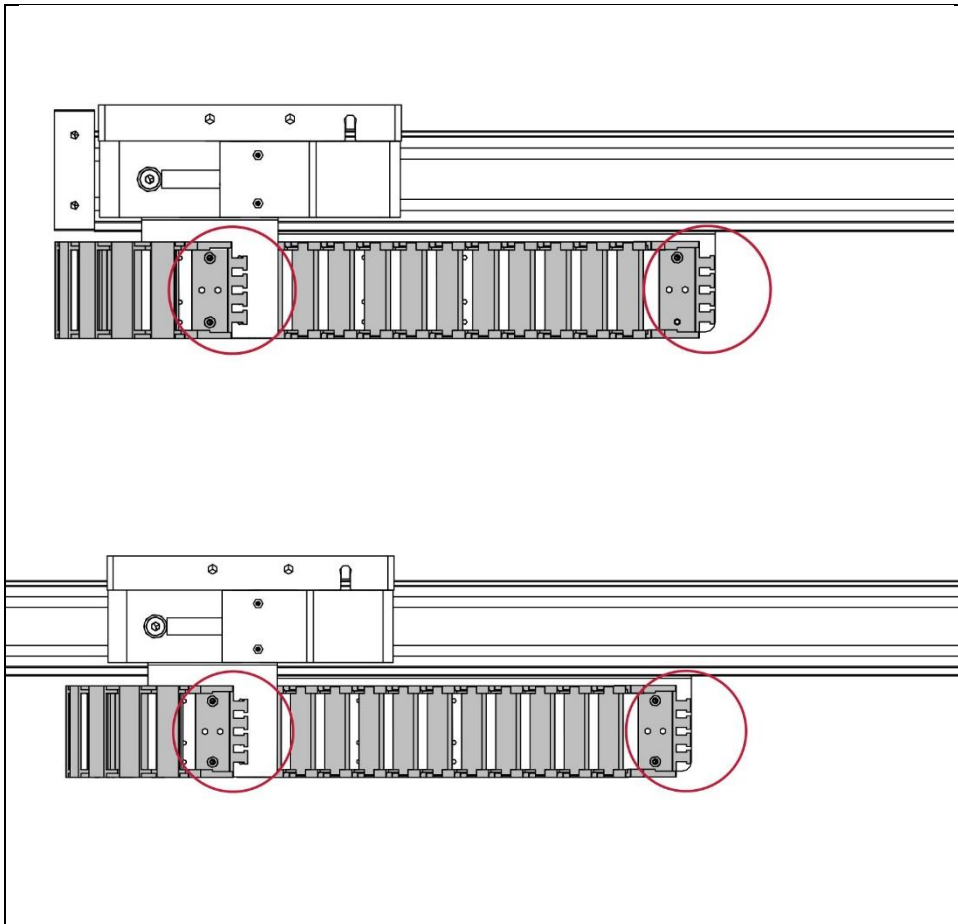

5. Fix the cables to the trailing chains on both sides with cable ties.

7.2.6 Cable exit centre/right with two carriages (0140-0055 option: Cable connector bottom centre/right)

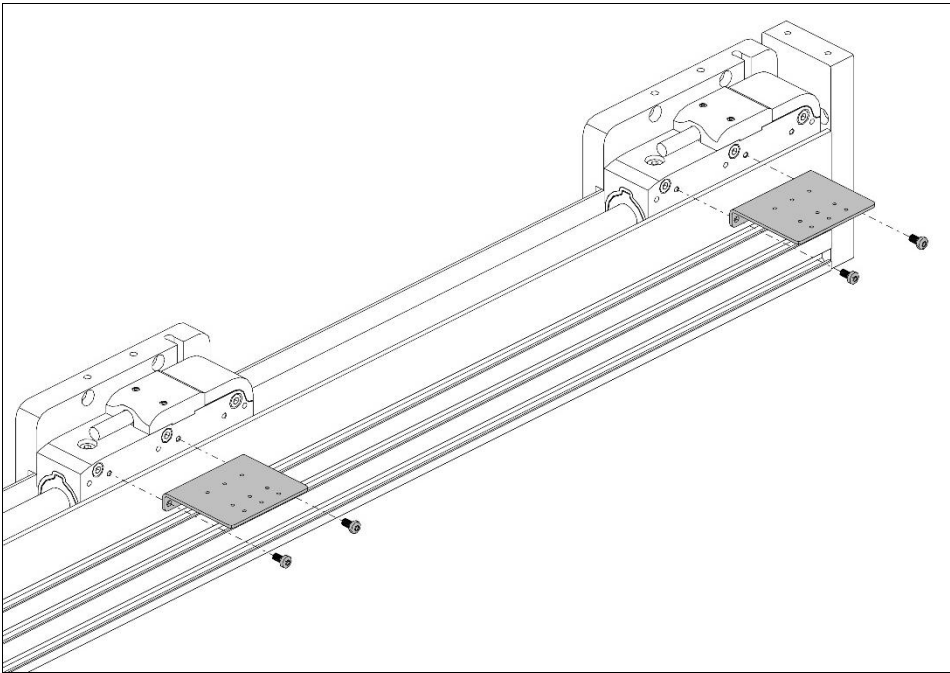

1. Mount the angle plates on the carriages. Use screw locking compound.

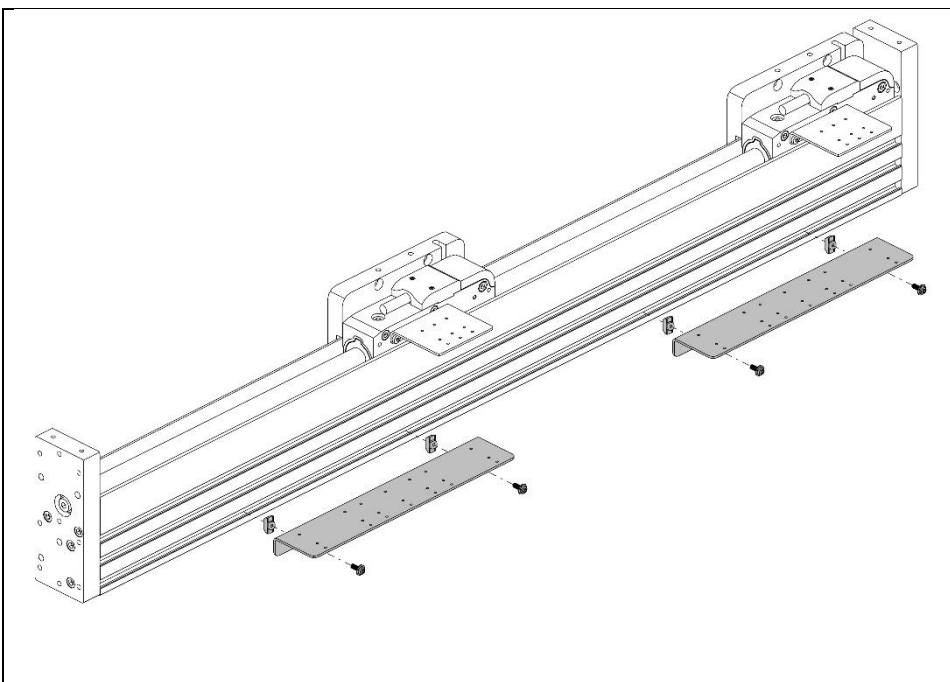

2. Mount the lower angle plates with T-nuts in the lower part of the module base. Longer lower angle plates have an additional fixing point in the centre.

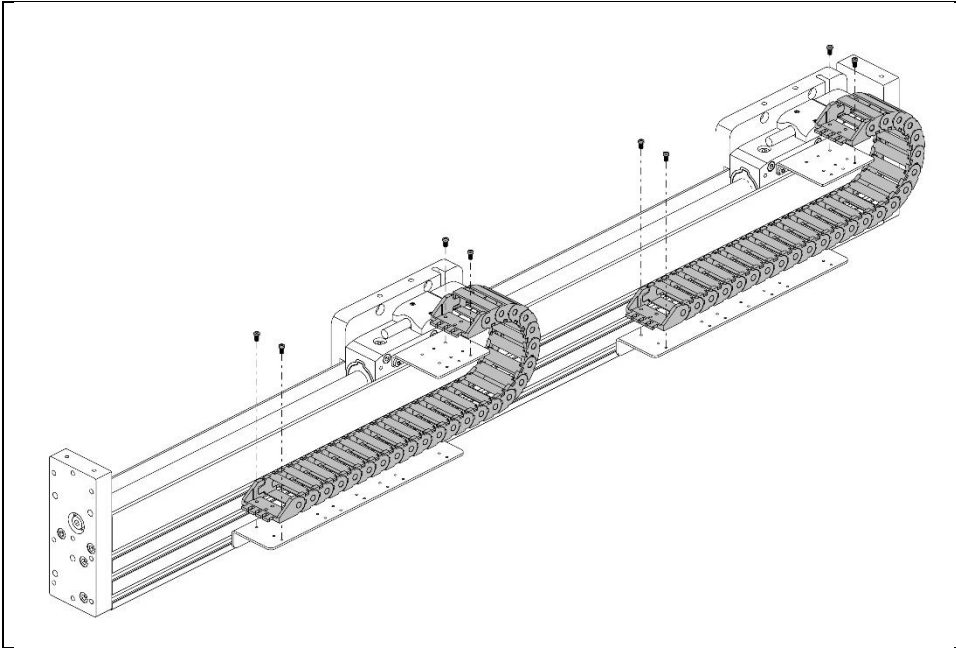

3. Insert the cables into the trailing chains and fit the trailing chains to the plates. Use screw locking compound.

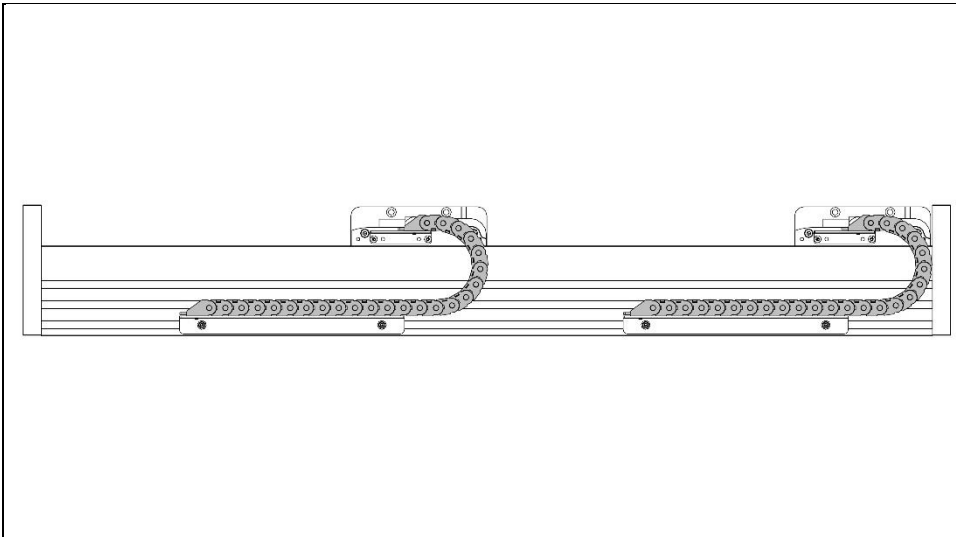

4. Align the lower angle plates so that the trailing chain (here on the right) with cable does not protrude from the module and the permissible cable bending radius is maintained. The carriages must be able to achieve the full required mechanical stroke.

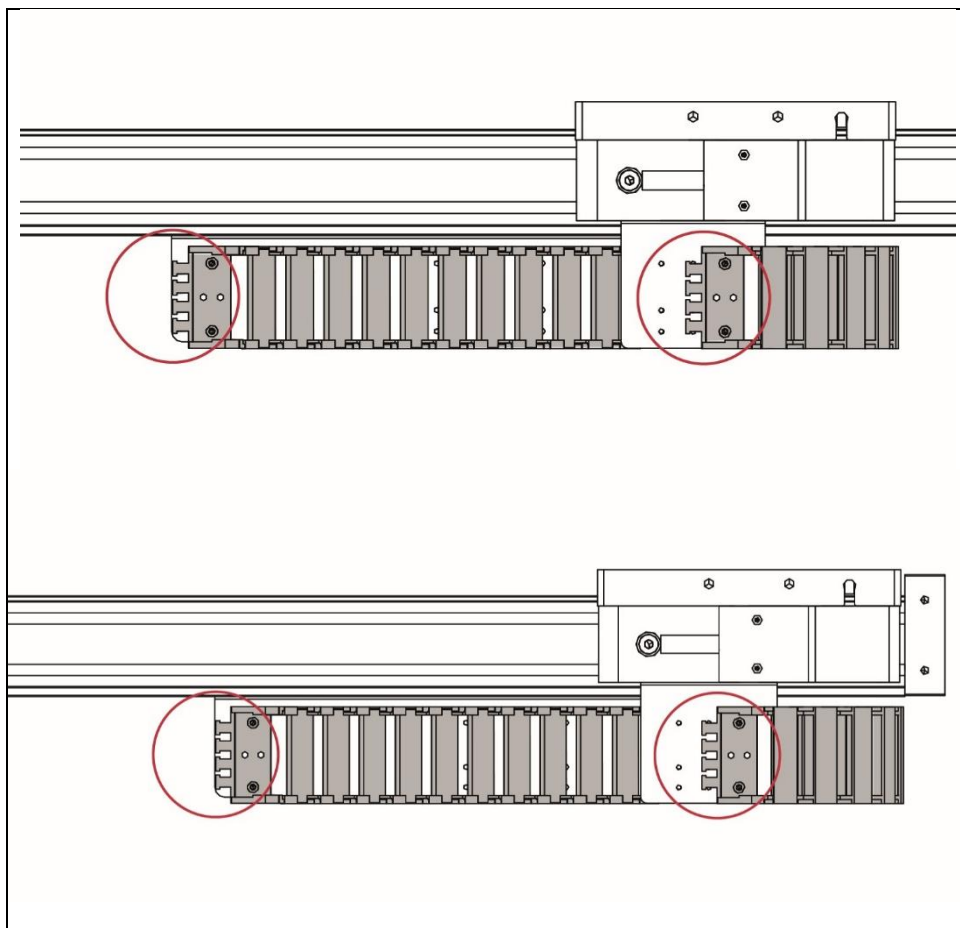

5. Fix the cables to the trailing chains on both sides with cable ties.

7.3 Motor cables

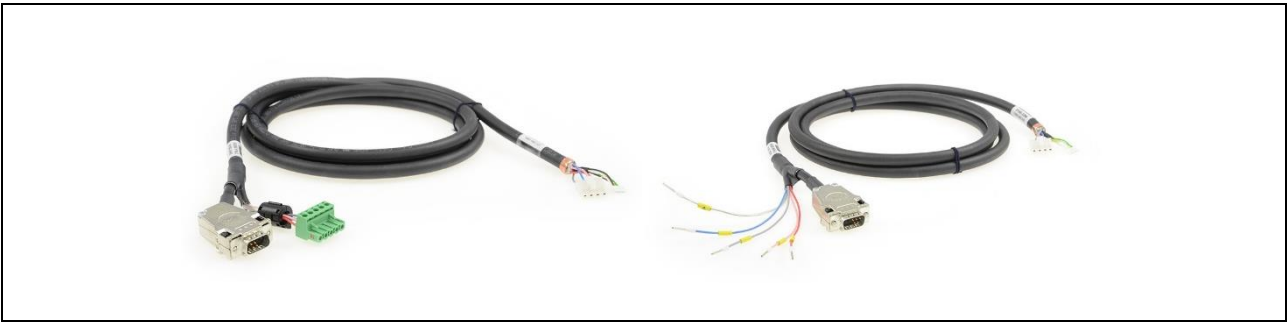

7.3.1 Motor cables for direct wiring

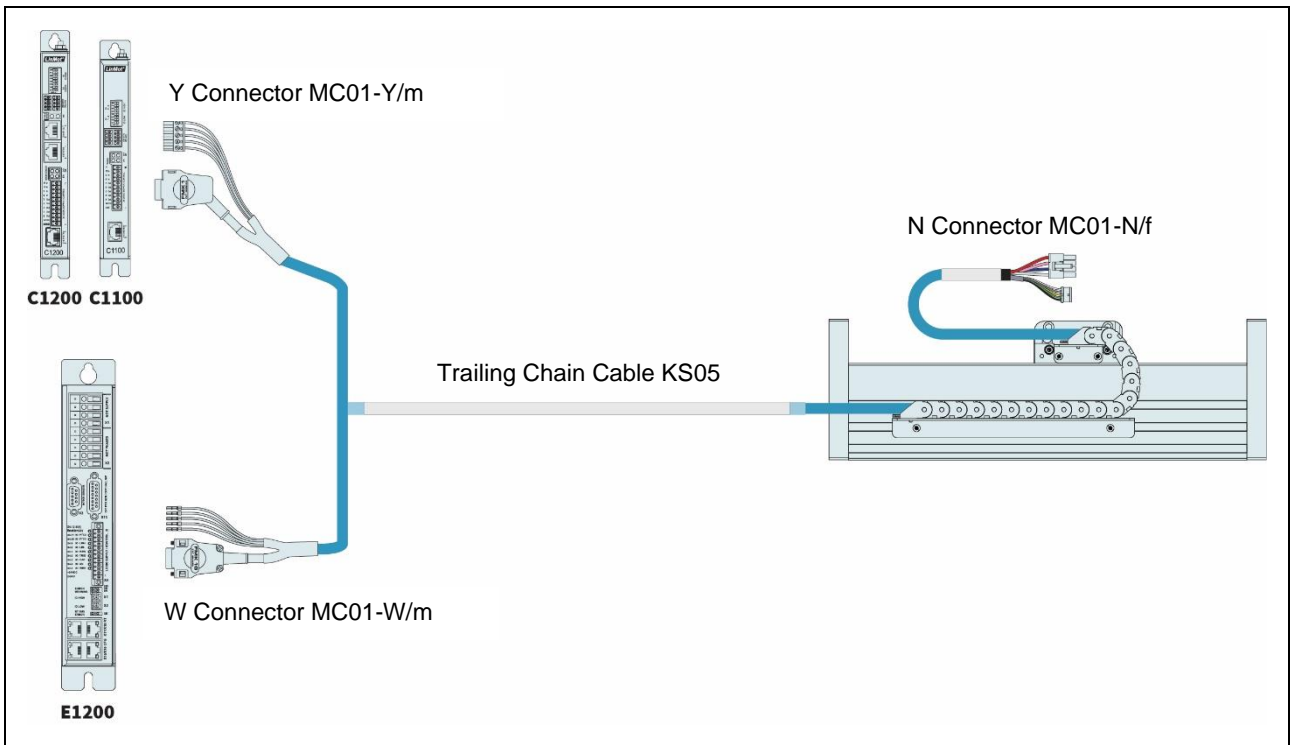

Item	Description	Item-No.
KS05-W/N-2	Trailing chain cable W/N, 2 m	0150-2296
KS05-W/N-4	Trailing chain cable W/N, 4 m	0150-2297
KS05-W/N-6	Trailing chain cable W/N, 6 m	0150-2298
KS05-W/N-8	Trailing chain cable W/N, 8 m	0150-2299
KS05-W/N-	Trailing chain cable W/N, custom length	0150-3412

Item	Description	Item-No.
KS05-Y/N-2	Trailing chain cable Y/N, 2 m	0150-2442
KS05-Y/N-4	Trailing chain cable Y/N, 4 m	0150-2443
KS05-Y/N-6	Trailing chain cable Y/N, 6 m	0150-2444
KS05-Y/N-8	Trailing chain cable Y/N, 8 m	0150-2445
KS05-Y/N-	Trailing chain cable Y/N, custom length	0150-3509

7.3.2 Motor cables for indirect wiring with fixed extension cable

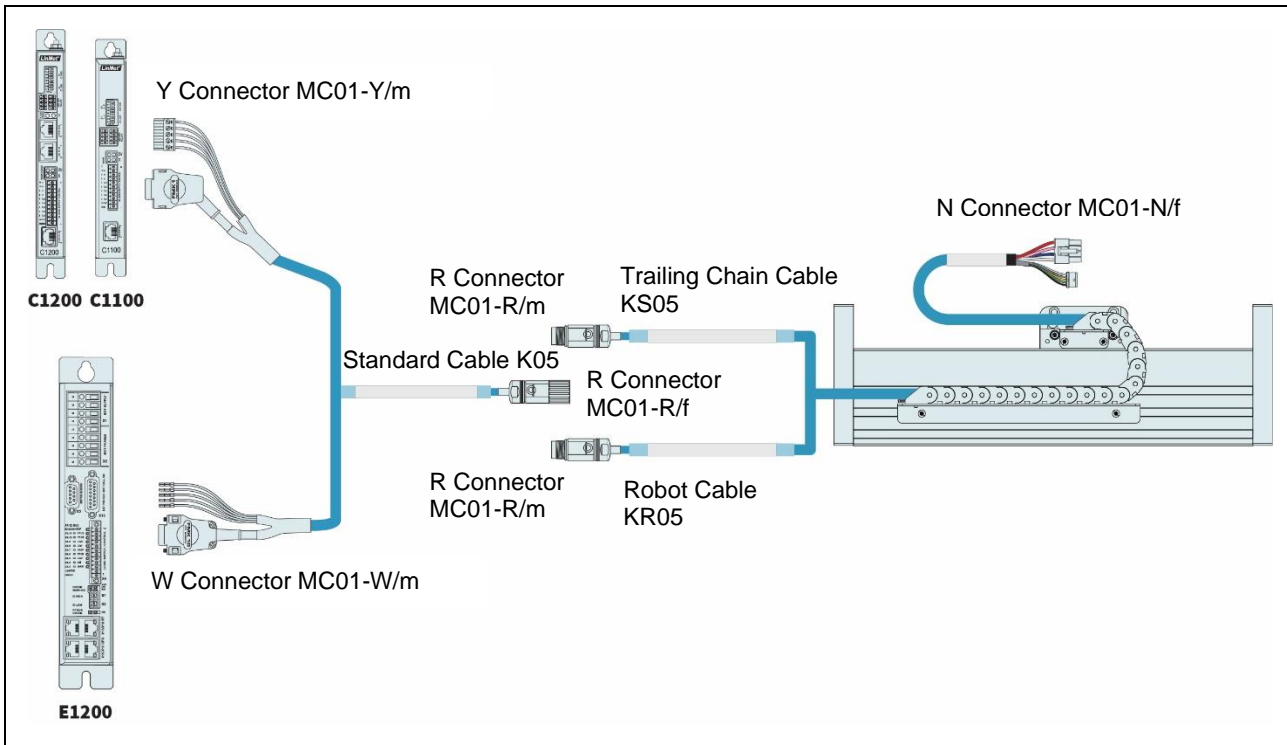

1st cable section: Intermediate -R connector to C1100/C1200 series drives (fixed installation)

Item	Description	Item-No.
K05-Y/R-2	Motor cable Y/R, 2 m	0150-2421
K05-Y/R-3	Motor cable Y/R, 3 m	0150-4854
K05-Y/R-4	Motor cable Y/R, 4 m	0150-2422
K05-Y/R-6	Motor cable Y/R, 6 m	0150-2423
K05-Y/R-8	Motor cable Y/R, 8 m	0150-2424
K05-Y/-Fe/R-	Motor cable Y/R, custom length	0150-3501

1st cable section: Intermediate -R connector to E1200 series drives (fixed installation)

Item	Description	Item-No.
K05-W/R-2	Motor cable W/R, 2 m	0150-2119
K05-W/R-3	Motor cable W/R, 3 m	0150-2459
K05-W/R-3.5	Motor cable W/R, 3.5 m	0150-2481
K05-W/R-4	Motor cable W/R, 4 m	0150-2120
K05-W/R-6	Motor cable W/R, 6 m	0150-2121
K05-W/R-8	Motor cable W/R, 8 m	0150-2122
K05-W/R-10	Motor cable W/R, 10 m	0150-2132
K05-W/R-	Motor cable W/R, custom length	0150-3262

2nd cable section: Motor to intermediate -R connector (in trailing chain)

Item	Description	Item-No.
KS05-09-R/N-1.5	Trailing chain cable R/N, 1.5 m (for guides)	0150-3880
KS05-09-R/N-2	Trailing chain cable R/N, 2 m (for guides)	0150-3881
KS05-09-R/N-3	Trailing chain cable R/N, 3 m (for guides)	0150-3882
KS05-R/N-	Trailing chain cable R/N, custom length	0150-3486
KR05-R/N-	Special cable R/N, custom length	0150-3757

8 External Sensors

For applications requiring maximum precision or absolute position measurement, LinMot offers direct integration of high quality position sensors.

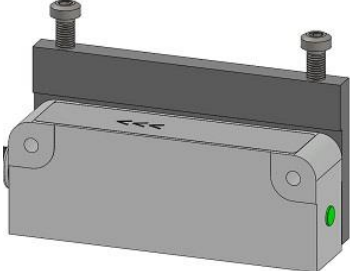
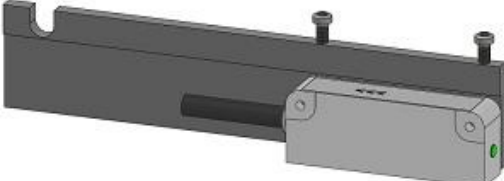
Sensor	Compatibility	Magnetic strip	Compatible drives
 <p>0150-5625</p> <p>FM01-37S/48-SK-D external sensor kit for FM01, incremental</p>	<p>This sensor can be used with the following linear modules:</p> <p>FM01-37x60 FM01-37x120 FM01-48x150 FM01-48x240 FM01-48x360</p>	<p>0150-1963</p> <p>MB01-1000 incremental magnetic strip for MS01-1/D (per cm)</p>	<p>C11x0 C12x0 C1250-MI C1251-MI C1252-MI E12x0</p>
 <p>0150-5635</p> <p>FM01-37/48-SK/02-D-BiSS external sensor kit for FM01, absolute</p>	<p>This sensor can be used with the following linear modules:</p> <p>FM01-37x60 FM01-48x150 FM01-48x240 FM01-48x360</p>	<p>0150-4730</p> <p>MB01-1000-ABS/BiSS absolute magnetic strip for E01-1/D-SSI (per cm)</p>	<p>C11x0 C12x0 C1250-MI C1251-MI C1252-MI</p>
 <p>0150-6115</p> <p>E01-SK02/D-BiSS external sensor kit for FM01, absolute</p>	<p>This sensor can be used with the following linear modules:</p> <p>FM01-37x120</p>	<p>0150-4730</p> <p>MB01-1000-ABS/BiSS absolute magnetic strip for E01-1/D-SSI (per cm)</p>	<p>C11x0 C12x0 C1250-MI C1251-MI C1252-MI</p>

8.1 Incremental sensor



Incremental sensor kit consists of external sensor, mounting brackets and screws. Magnetic strip and additional cables must be ordered separately.

Item	Description	Item-No.
FM01-37S/48-SK-D	External Sensor kit for FM-Module, 2 m (incremental)	0150-5625



You can find more detailed information about external sensor such as detailed mechanical dimensions, counting directions, installation alignment and connector wiring in the external sensor data sheet.

Due to installation and alignment difficulty, it is highly recommended to order the external sensor kit together with the guide.

8.1.1 Overview sensor kit (incremental)

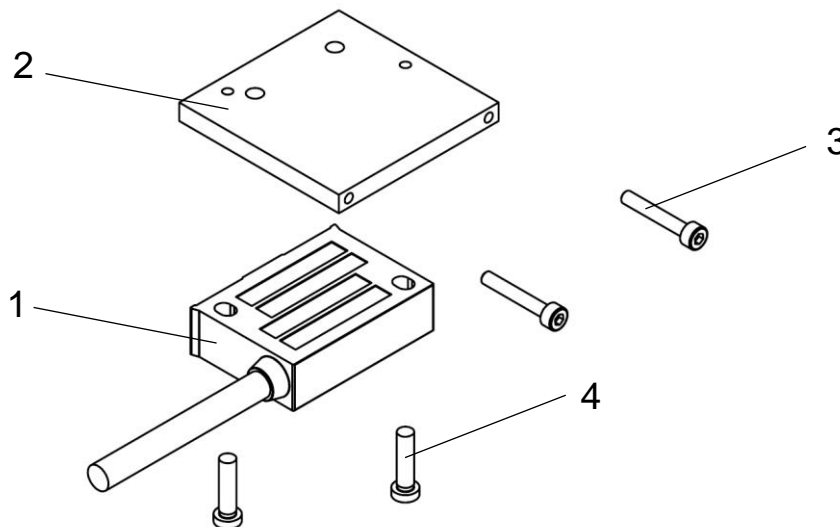

Pos.	Item
1	Magnet sensor MS01-1/D
2	Sensor adapter
3	M2.5x16 / ISO 7046-2
4	M2.5x10 / ISO 14583
-	Cable clamp (not pictured)
-	M2.5x6 / ISO 7046-2 (not pictured)

8.1.2 Dimensions

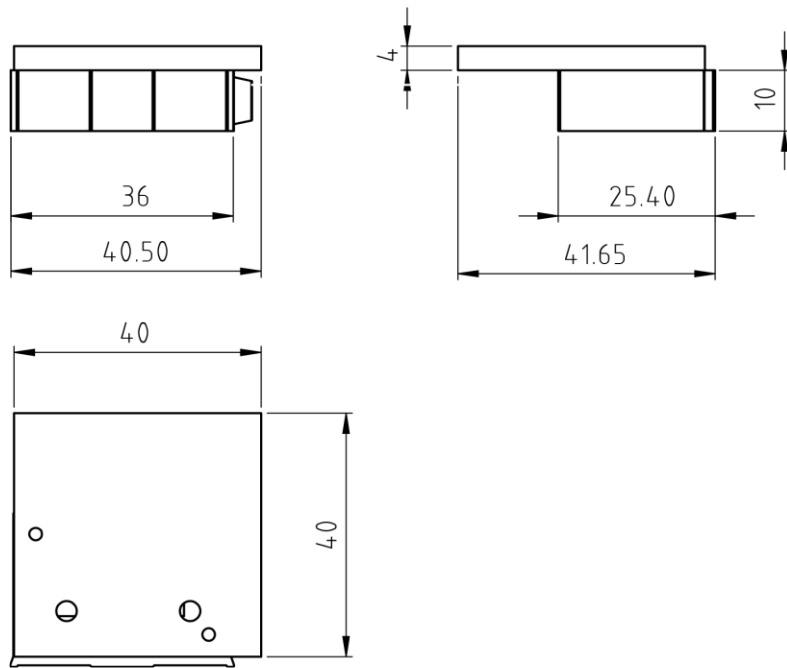

8.1.3 Magnetic strips for incremental sensor

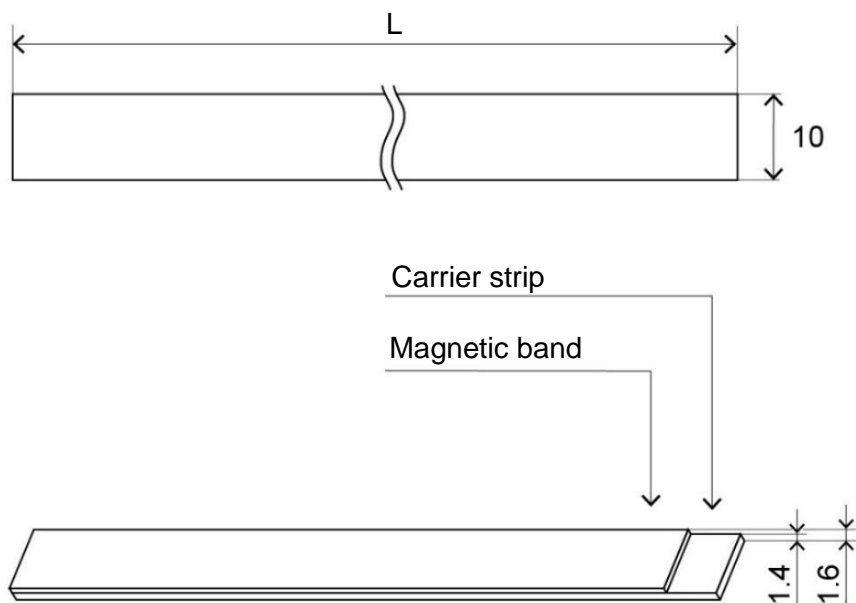

Item	Description	Strip length L [mm (inch)]	Item-No.
F01-MB300	Magnetic strip for E/F-Guide (incremental)	280 (11.02)	0150-5454
F01-MB400	Magnetic strip for E/F-Guide (incremental)	380 (14.96)	0150-5451
F01-MB500	Magnetic strip for E/F-Guide (incremental)	480 (18.9)	0150-5452
F01-MB600	Magnetic strip for E/F-Guide (incremental)	580 (22.83)	0150-5431
F01-MB800	Magnetic strip for E/F-Guide (incremental)	780 (30.71)	0150-5432
F01-MB1000	Magnetic strip for E/F-Guide (incremental)	980 (38.58)	0150-5433
F01-MB1200	Magnetic strip for E/F-Guide (incremental)	1180 (46.46)	0150-5434
F01-MB1400	Magnetic strip for E/F-Guide (incremental)	1380 (54.33)	0150-5435
F01-MB1600	Magnetic strip for E/F-Guide (incremental)	1580 (62.2)	0150-5436
F01-MB2000	Magnetic strip for E/F-Guide (incremental)	1980 (77.95)	0150-5437

8.1.4 Extender incremental sensor cable



Item	Description	Item-No.
KS025-D15/D-Encoder	Encoder Cable, High Flex, Custom length	0150-3168

8.2 Absolute sensor BiSS



BiSS absolute sensor kit consists of external sensor, mounting brackets and screws. Magnetic strip and additional cables must be ordered separately.

Item	Description	Item-No.
FM01-37/48-SK02/D-BiSS	External Sensor kit for FM-Module, 2m (absolute)	0150-5635



You can find more detailed information about external sensor such as detailed mechanical dimensions, counting directions, installation alignment and connector wiring in the external sensor data sheet.

Due to installation and alignment difficulty, it is highly recommended to order the external sensor kit together with the guide.

8.2.1 Magnetic strips for absolute sensor BiSS

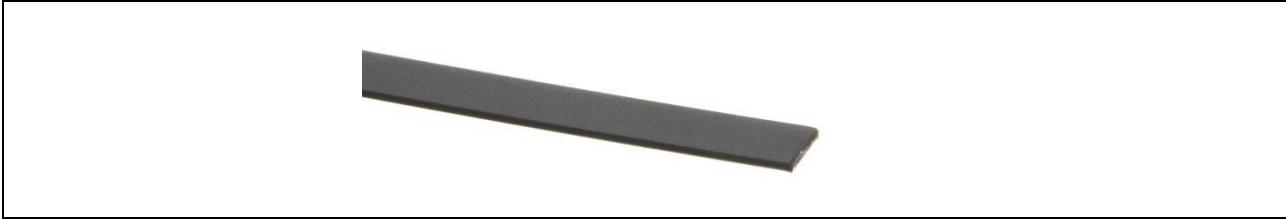

Item	Description	Strip length L [mm (inch)]	Item-No.
MB01-ABS/BiSS-28	Magnetic strip for E/F-Guide (absolute)	280 (11.02)	0150-4910
MB01-ABS/BiSS-38	Magnetic strip for E/F-Guide (absolute)	380 (14.96)	0150-4911
MB01-ABS/BiSS-48	Magnetic strip for E/F-Guide (absolute)	480 (18.90)	0150-4912
MB01-ABS/BiSS-58	Magnetic strip for E/F-Guide (absolute)	580 (22.83)	0150-4913
MB01-ABS/BiSS-78	Magnetic strip for E/F-Guide (absolute)	780 (30.71)	0150-4914
MB01-ABS/BiSS-98	Magnetic strip for E/F-Guide (absolute)	980 (38.58)	0150-4915
MB01-ABS/BiSS-118	Magnetic strip for E/F-Guide (absolute)	1180 (46.46)	0150-4917
MB01-ABS/BiSS-138	Magnetic strip for E/F-Guide (absolute)	1380 (54.33)	0150-4919
MB01-ABS/BiSS-158	Magnetic strip for E/F-Guide (absolute)	1580 (62.20)	0150-4920
MB01-ABS/BiSS-198	Magnetic strip for E/F-Guide (absolute)	1980 (77.95)	0150-4923

8.2.2 Absolute sensor BiSS cables



Item	Description	Item-No.
KSS01-12-D15/ABS-ENC-	For MS01-1/D-SSI/BiSS, Custom length	0150-3652

8.3 Absolute sensor BiSS for FM01-37x120 modules

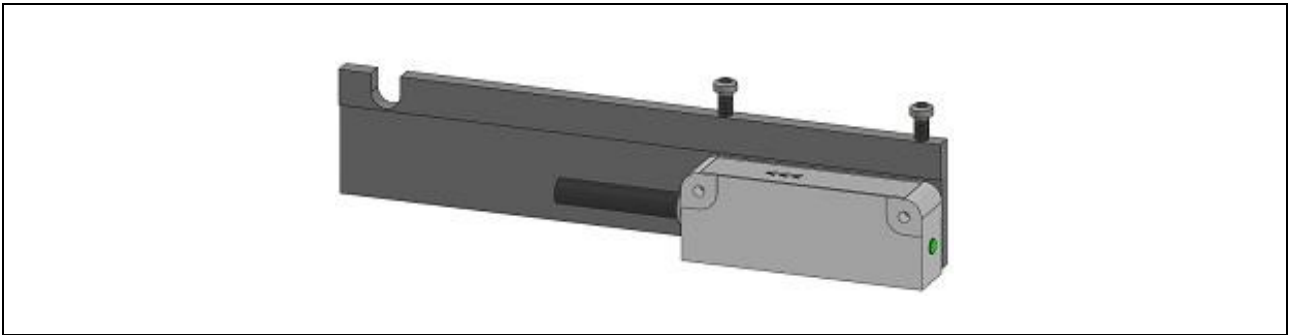

BiSS absolute sensor kit consists of external sensor, cable, mounting brackets and screws. Magnetic strip and additional cables must be ordered separately.

Item	Description	Item-No.
E01-SK02/D-BiSS	External Sensor kit for EM-Module, 2m (absolute)	0150-4721



You can find more detailed information about external sensor such as detailed mechanical dimensions, counting directions, installation alignment and connector wiring in the external sensor data sheet.

Due to installation and alignment difficulty, it is highly recommended to order the external sensor kit together with the guide.

8.3.1 Magnetic strips for absolute sensor BiSS



Item	Description	Strip length L [mm (inch)]	Item-No.
MB01-ABS/BiSS-28	Magnetic strip for E/F-Guide (absolute)	280 (11.02)	0150-4910
MB01-ABS/BiSS-38	Magnetic strip for E/F-Guide (absolute)	380 (14.96)	0150-4911
MB01-ABS/BiSS-48	Magnetic strip for E/F-Guide (absolute)	480 (18.90)	0150-4912
MB01-ABS/BiSS-58	Magnetic strip for E/F-Guide (absolute)	580 (22.83)	0150-4913
MB01-ABS/BiSS-78	Magnetic strip for E/F-Guide (absolute)	780 (30.71)	0150-4914
MB01-ABS/BiSS-98	Magnetic strip for E/F-Guide (absolute)	980 (38.58)	0150-4915
MB01-ABS/BiSS-118	Magnetic strip for E/F-Guide (absolute)	1180 (46.46)	0150-4917
MB01-ABS/BiSS-138	Magnetic strip for E/F-Guide (absolute)	1380 (54.33)	0150-4919
MB01-ABS/BiSS-158	Magnetic strip for E/F-Guide (absolute)	1580 (62.20)	0150-4920
MB01-ABS/BiSS-198	Magnetic strip for E/F-Guide (absolute)	1980 (77.95)	0150-4923

8.3.2 Absolute sensor BiSS cables



Item	Description	Item-No.
KSS01-12-D15/ABS-ENC-	Special Cable for MS01-1/D-SSI/BiSS, Custom length, (max. 10 metres, can be extended with 0150-3717)	0150-3652

9 Maintenance

9.1 Maintenance cycles

9.1.1 Profile rail guide maintenance cycles

To avoid dirt from adhering to and embedding into the profile rail guides, the rails should be cleaned regularly with a “cleaning stroke”. SKF recommends a cleaning stroke over the entire length of the rails twice a day or at least every eight hours. Perform a cleaning stroke each time when switching the machine on or off. It is sufficient to clean the heavy soiled carriage rails only with a soft disposable paper.

The lubrication intervals for profile rail guides depend primarily on the average running speed, operating temperature and grease quality. Lubrication interval under normal operating condition ($v < 1\text{m/s}$) with travel under load $F_m \leq 0.15\text{ C}$ is 5000 km and with travel under load $F_m \leq 0.3\text{ C}$ is 1200 km.

Where contamination, use of coolants, vibration, shock loads etc. form part of the environmental conditions, it is advisable to reduce relubrication intervals accordingly.

F_m determination and more information regarding maintenance can be found in SKF manual “Profile rail guides LLT 12942”.

9.1.2 Linear motor (stator and slider) maintenance cycles

The stators are initially lubricated at the factory. Lubrication is only necessary if the linear motor run dry or is heavily soiled. Under normal industrial, central European conditions (5-day week with 8 hours of operation per day), a quarterly inspection is sufficient. It is advisable to check the stator together with the carriages.

The inspection cycle must be shortened if there are heavy loads or deviating conditions. These are e.g.

- Permanent soiling
- Direct sunlight
- Low humidity
- Outdoor operation
- Increased operating temperature
- Strong shocks or vibrations
- Other special environmental conditions

9.2 Inspection

When inspecting, the following points must be checked:

- a) Visual inspection of lubrication grease level (clean and re-lubricate if necessary)
- b) Visual inspection of all wearing parts (replace if necessary)

9.3 Cleaning and lubrication



Carriages and stator use different greases. Make sure that they are not exchanged or mixed!

9.3.1 Profile rail guides and carriages cleaning and lubrication

1. Remove the accommodated soiling. Move the carriage to side to access all soiled parts. It is important that no paper residue is left anywhere on the guide.
2. Each carriage is equipped with a side grease nipple. Access the grease nipple with filler and grease each carriage with 0.4 cm³ SKF LGEP 2. **Do not overlubricate!**
3. Move the carriage three times over the entire stroke. Remove any excessive grease and soil while moving the carriage.
4. If no lubricating film is visible on the rail, repeat step 2 and 3.

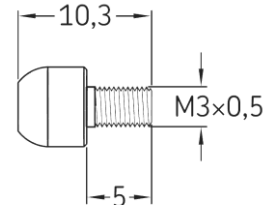

9.3.2 Linear motor (stator and slider) cleaning and lubrication

1. Clean slider with disposable paper and LU06 cleaning spray. Move the stator to side to access all soiled parts.
2. By moving the stator over cleaned parts of the slider, a residual soil from the stator bore will be smeared out soiling the slider again. Repeat step 1 and 2 until entire remaining residual soil from stator and slider is removed.
3. Grease the slider with grease LU02 so, that the lubricating film of grease is visible. Move the stator through entire stroke on the slider. If no lubricating film is visible on the slider, repeat. **Do not overlubricate!** Remove any excessive grease while moving the stator.



The FM modules can be cleaned and lubricated without disassembly. However, if disassembly and/or assembly is required, it is recommended that the following trained companies be commissioned:

- LinMot
- Companies qualified by LinMot



However, assembly, disassembly and inspection can be carried out by the customer (see steps 1 to 6 below). The following points must be observed:

- Ensure that the radial alignment of the slider is the same before and after assembly.
- Only loosen enough screws so that no realignment of the carriage/bearing/rail etc. is required. Incorrect alignment can lead to premature wear and increased friction.
- Care must be taken to ensure that the balls do not fall out of the bearings, both when dismantling and when mounting the carriages on the profile rail.
- In modules with several carriages, the order of the carriages must not be changed.
- Incorrect inspection, assembly or disassembly may result in premature wear of wear parts and/or damage to the linear module and/or its components and may invalidate the warranty.

1. Remove the right end plate and slide off the carriage with stator.
2. Clean slider and the stator bore with disposable paper and LU06 cleaning spray. It is important that no paper residue is left anywhere on the guide.
3. Grease the slider with grease LU02 so that the lubricating film of grease is visible.
4. Slide the carriage with stator cautiously back onto the module basis. **Warning:** If the carriage is pushed on at an angle, there is a risk that the ball bearings will be damaged. If this is the case, the linear module must be returned and a repair case will occur.
5. Screw back removed end plate, use thread locking compound.
6. Move the stator through entire stroke on the slider. If no lubricating film is visible on the slider, lubricate the slider. Repeat until small film of grease is visible. **Warning:** Overgreasing can lead to gumming of the grease, especially at higher operating temperatures. Remove any excessive grease while moving the stator.

Ordering Information

Item	Description	Item-No.
LU06-250	Maintenance spray for linear motors (250ml)	0150-2394
LU02-50	Lubricant for linear motors (50ml)	0150-1954
LU02-1000	Lubricant for linear motors (1000ml)	0150-1955

10 Storage and Transport

- LinMot linear guides may only be transported and stored in their original packaging.
- The linear guides may only be removed from the packaging when they are installed.
- The storage room must be dry, dust-free, frost-free and vibration-free.
- The relative humidity should be below 60%.
- Recommended storage temperature: -15 °C...70 °C
- The linear guide must be protected from extreme weather conditions.
- The ambient air must not contain aggressive gases.

11 Dimensions & Weights

11.1 FM01-37-xxx_xxx_1CF37Sx60-HP

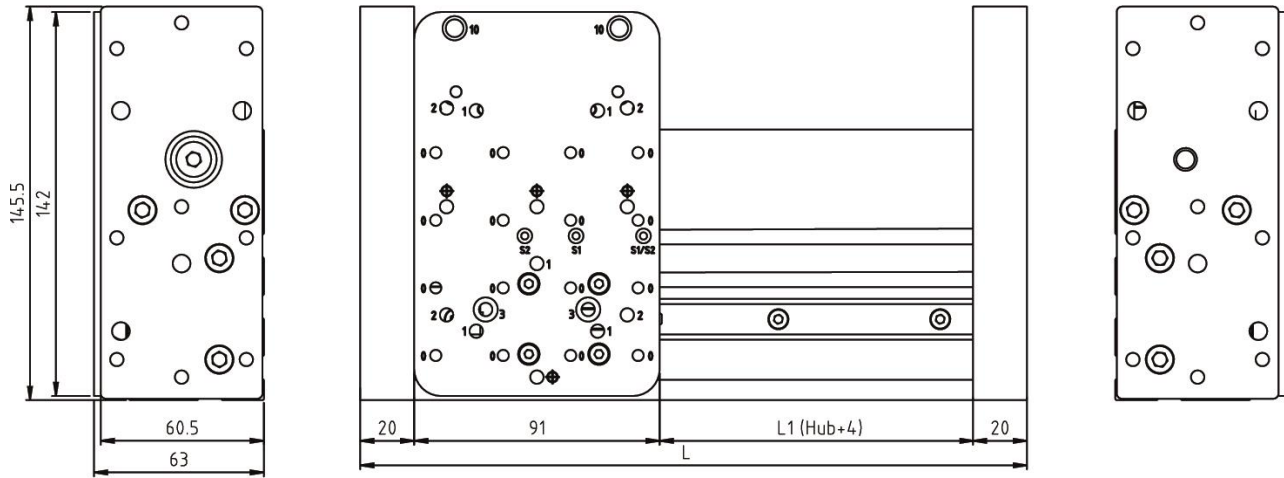

Linear Module FM01-37...	Stroke H ¹ [mm (inch)]	Length L [mm (inch)]	Moving mass ¹ [g (lb)]	Total weight ¹ [g (lb)]
...-330_195_1CF37Sx60-HP-BE01-MD01-N	195 (7.68)	330 (13.0)	591 (1.30)	6815 (15.02)
...-430_295_1CF37Sx60-HP-BE01-MD01-N	295 (11.61)	430 (16.93)	591 (1.30)	7743 (17.07)
...-530_395_1CF37Sx60-HP-BE01-MD01-N	395 (15.55)	530 (20.87)	591 (1.30)	8815 (19.43)
...-630_495_1CF37Sx60-HP-BE01-MD01-N	495 (19.49)	630 (24.80)	591 (1.30)	9767 (21.53)
...-830_695_1CF37Sx60-HP-BE01-MD01-N	695 (27.36)	830 (32.68)	591 (1.30)	11685 (25.76)
...-1030_895_1CF37Sx60-HP-BE01-MD01-N	895 (35.24)	1030 (40.55)	591 (1.30)	13592 (29.97)
...-1230_1095_1CF37Sx60-HP-BE01-MD02-N	1095 (43.11)	1230 (48.43)	591 (1.30)	15653 (34.51)
...-1430_1295_1CF37Sx60-HP-BE01-MD02-N	1295 (50.98)	1430 (56.30)	591 (1.30)	17582 (38.76)
...-1630_1495_1CF37Sx60-HP-BE01-MD02-N	1495 (58.86)	1630 (64.17)	591 (1.30)	19564 (43.13)
...-2030_1895_1CF37Sx60-HP-BE01-MD02-N	1895 (74.61)	2030 (79.92)	591 (1.30)	23528 (51.87)

¹Stroke, moving mass and total weight differ in the configuration with several carriages.

11.2 FM01-37-xxx_xxx_1CF37x120F-HP

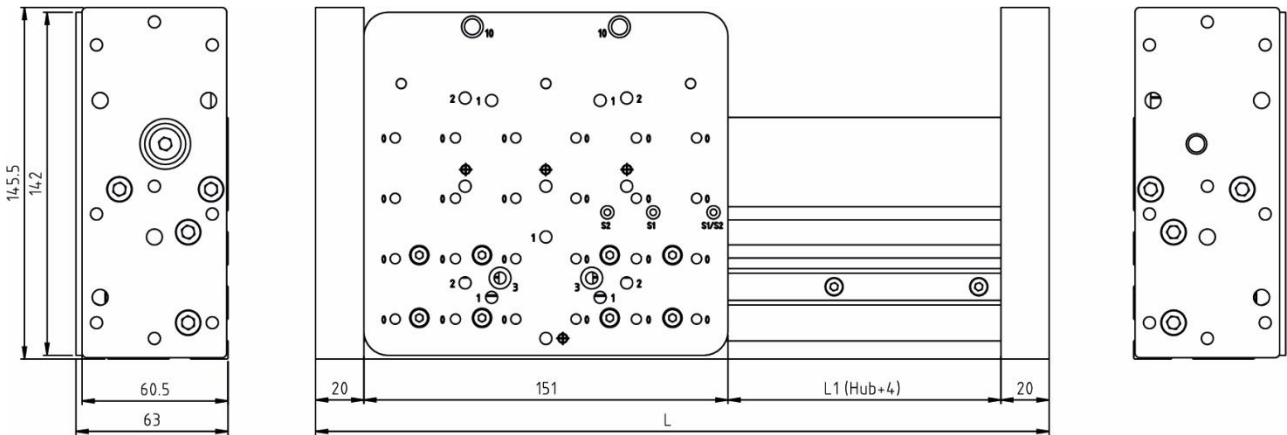

Linear Module FM01-37...	Stroke H ¹ [mm (inch)]	Length L [mm (inch)]	Moving mass ¹ [g (lb)]	Total weight ¹ [g (lb)]
...-330_135_1CF37Sx120F-HP-BE02-MD01-N	135 (5.31)	330 (13.0)	1579 (3.48)	6985 (15.40)
...-430_235_1CF37Sx120F-HP-BE02-MD01-N	235 (9.25)	430 (16.93)	1579 (3.48)	7913 (17.45)
...-530_335_1CF37Sx120F-HP-BE02-MD01-N	335 (13.19)	530 (20.87)	1579 (3.48)	8985 (19.81)
...-630_435_1CF37Sx120F-HP-BE02-MD01-N	435 (17.13)	630 (24.80)	1579 (3.48)	9937 (21.91)
...-830_635_1CF37Sx120F-HP-BE02-MD01-N	635 (25.0)	830 (32.68)	1579 (3.48)	11855 (26.14)
...-1030_835_1CF37Sx120F-HP-BE02-MD01-N	835 (32.87)	1030 (40.55)	1579 (3.48)	13761 (30.38)
...-1230_1035_1CF37Sx120F-HP-BE02-MD02-N	1035 (40.75)	1230 (48.43)	1579 (3.48)	15671 (34.55)
...-1430_1235_1CF37Sx120F-HP-BE02-MD02-N	1235 (48.62)	1430 (56.30)	1579 (3.48)	17600 (38.80)
...-1630_1435_1CF37Sx120F-HP-BE02-MD02-N	1435 (56.50)	1630 (64.17)	1579 (3.48)	19581 (43.17)
...-2030_1835_1CF37Sx120F-HP-BE02-MD02-N	1835 (72.24)	2030 (79.92)	1579 (3.48)	23546 (51.91)

¹Stroke, moving mass and total weight differ in the configuration with several carriages.

11.3 End plates

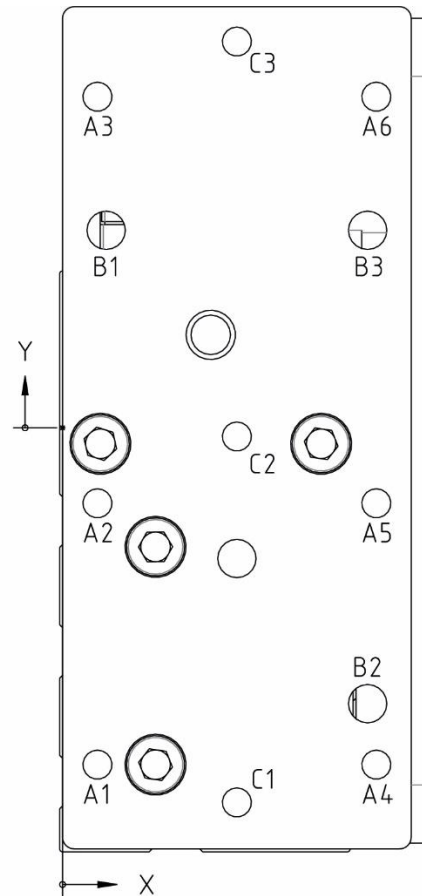
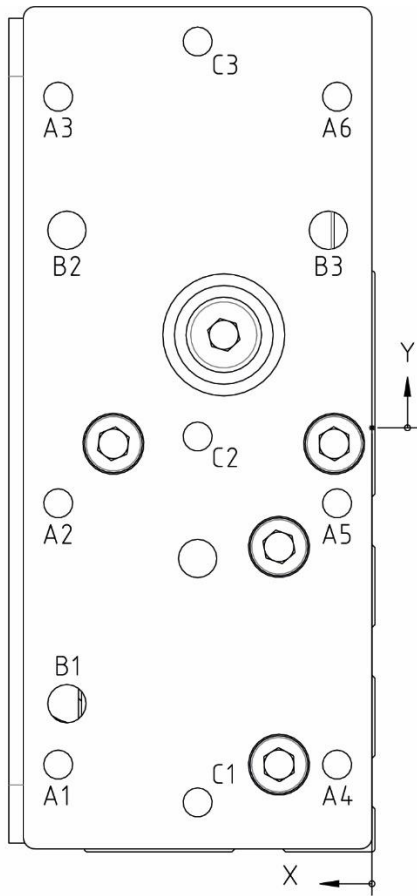

	X-POS.	Y-POS.	
A1	54	-58	$\varnothing 5 \begin{smallmatrix} \nabla \\ \nabla \end{smallmatrix} 17$ $M6 - 6H \begin{smallmatrix} \nabla \\ \nabla \end{smallmatrix} 12$
A2	54	-13	
A3	54	57	
A4	6	-58	
A5	6	-13	
A6	6	57	
B1	52.50	-47.50	$\varnothing 6.6$ $\sqcup \varnothing 10.5 \begin{smallmatrix} \nabla \\ \nabla \end{smallmatrix} 6.4$
B2	52.50	34	
B3	7.50	34	
C1	30	-64.50	$\varnothing 5 H7 \begin{smallmatrix} +0.012 \\ 0 \end{smallmatrix} \begin{smallmatrix} \nabla \\ \nabla \end{smallmatrix} 12$
C2	30	-1.50	
C3	30	66.50	

	X-POS.	Y-POS.	
A1	6	-58	$\varnothing 5 \begin{smallmatrix} \nabla \\ \nabla \end{smallmatrix} 17$ $M6 - 6H \begin{smallmatrix} \nabla \\ \nabla \end{smallmatrix} 12$
A2	6	-13	
A3	6	57	
A4	54	-58	
A5	54	-13	
A6	54	57	
B1	7.50	34	$\varnothing 6.6$ $\sqcup \varnothing 11 \begin{smallmatrix} \nabla \\ \nabla \end{smallmatrix} 6.4$
B2	52.50	-47.50	
B3	52.50	34	
C1	30	-64.50	$\varnothing 5 H7 \begin{smallmatrix} +0.012 \\ 0 \end{smallmatrix} \begin{smallmatrix} \nabla \\ \nabla \end{smallmatrix} 12$
C2	30	-1.50	
C3	30	66.50	

11.4 Mounting plate FM01-37-xxx_xxx_1CF37Sx60-HP

	X-POS.	Y-POS.	
A1	-37.50	15	∅ 4.2 M5 - 6H
A2	-37.50	40	
A3	-37.50	65	
A4	-37.50	90	
A5	-12.50	15	
A6	-12.50	40	
A7	-12.50	65	
A8	-12.50	90	
A9	12.50	15	
A10	12.50	40	
A11	12.50	65	
A12	12.50	90	
A13	37.50	15	
A14	37.50	40	
A15	37.50	65	
A16	37.50	90	
B1	-33.50	30	∅ 5 M6 - 6H
B2	-33.50	106.50	
B3	-22.50	24	
B4	-22.50	105.50	
B5	0	49	
B6	22.50	24	
B7	22.50	105.50	
B8	33.50	30	
B9	33.50	106.50	
C1	-33.50	70	∅ 5 H7 0 ^{+0.012} ∇ 10
C2	0	7	
C3	0	70	
C4	33.50	70	
D1	30.50	136	└─ ∅ 11 ∇ 6.4 └─ ∅ 9 H7 0 ^{+0.015} ∇ 2 ∅ 6.6
D2	-30.50	136	

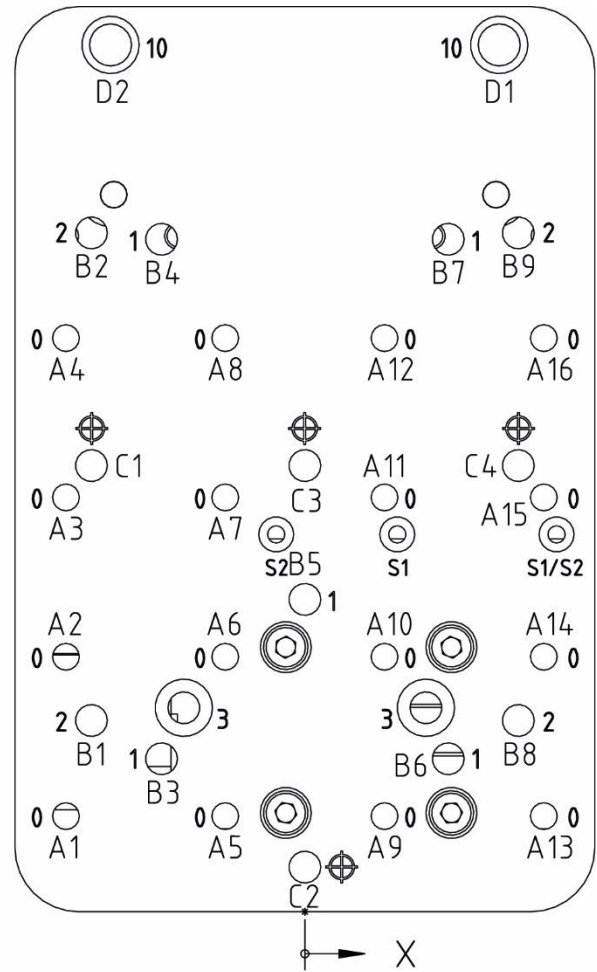

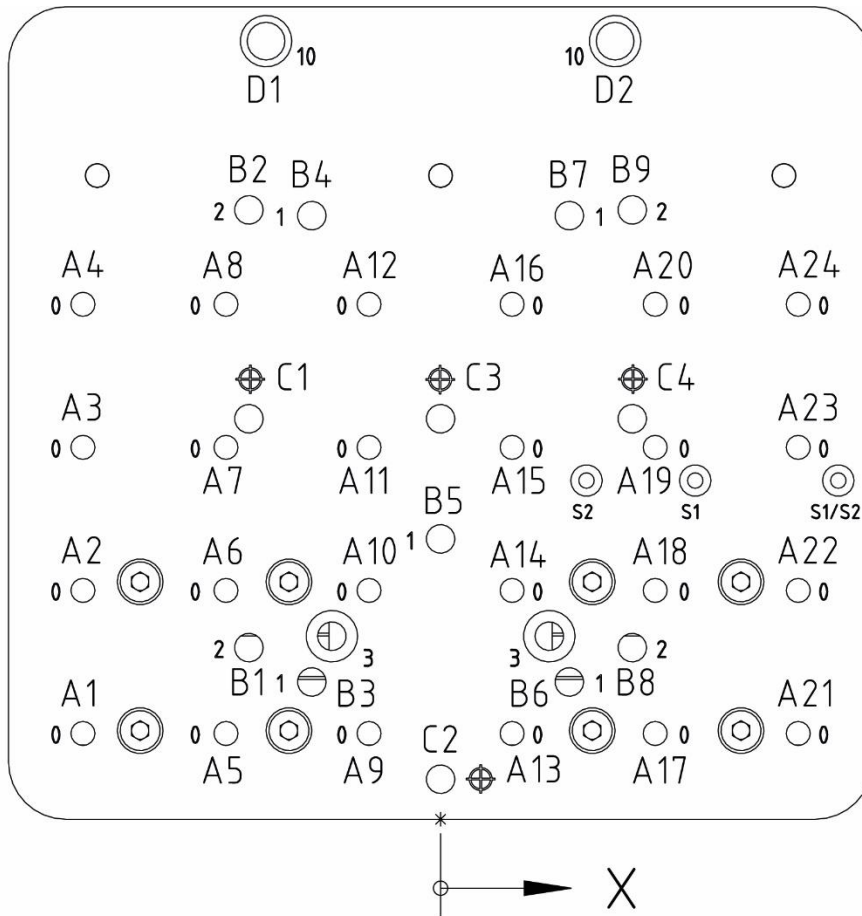

11.5 Mounting plate FM01-37-xxx_xxx_1CF37Sx120F-HP



	X-POS.	Y-POS.	
A1	-62.50	15	ϕ 4.2 M5 - 6H
A2	-62.50	40	
A3	-62.50	65	
A4	-62.50	90	
A5	-37.50	15	
A6	-37.50	40	
A7	-37.50	65	
A8	-37.50	90	
A9	-12.50	15	
A10	-12.50	40	
A11	-12.50	65	
A12	-12.50	90	
A13	12.50	15	
A14	12.50	40	
A15	12.50	65	
A16	12.50	90	
A17	37.50	15	
A18	37.50	40	
A19	37.50	65	
A20	37.50	90	
A21	62.50	15	
A22	62.50	40	
A23	62.50	65	
A24	62.50	90	

	X-POS.	Y-POS.	
B1	-33.50	30	ϕ 5 M6 - 6H
B2	-33.50	106.50	
B3	-22.50	24	
B4	-22.50	105.50	
B5	0	49	
B6	22.50	24	
B7	22.50	105.50	
B8	33.50	30	
B9	33.50	106.50	
C1	-33.50	70	ϕ 5 H7 0 \downarrow 10 +0.012
C2	0	7	
C3	0	70	
C4	33.50	70	
D1	-30.50	136	\sqsubset ϕ 11 \downarrow 6.4 +0.015 \sqsubset ϕ 9 H7 0 \downarrow 2 ϕ 6.6
D2	30.50	136	

12 International Certificates

<p>Europe</p> 	<p>See chapter “EU Declaration of Conformity CE-Marking”</p>
<p>UK</p> 	<p>See chapter “UK Declaration of Conformity UKCA-Marking”</p>
<p>IECEE CB SCHEME</p>	<p>Ref. Certif. Nr. CH-8521</p>

	Ref. Certif. No.
	CH-8521



IEC SYSTEM FOR MUTUAL RECOGNITION OF TEST CERTIFICATES FOR ELECTRICAL EQUIPMENT (IECEE) CB SCHEME

CB TEST CERTIFICATE

Product	Linear motor	
Name and address of the applicant	NTI AG	Bodenackerstrasse 2 SWITZERLAND 8957 Spreitenbach
Name and address of the manufacturer	NTI AG	Bodenackerstrasse 2 SWITZERLAND 8957 Spreitenbach
Name and address of the factory	NTI AG	Bodenackerstrasse 2 SWITZERLAND 8957 Spreitenbach
<i>Note: When more than one factory, please report on page 2</i>	<input type="checkbox"/> Additional Information on page 2	
Ratings and principal characteristics	supplied via servo drive, see TR 17-EL-0006.E02 for details	
Trade mark (if any)	LinMot	
Customers's Testing Facility (CTF) Stage used	---	
Model / Type Ref.	PR series PS series P04 series P05 series	
Additional information (if necessary may also be reported on page 2)	---	
A sample of product was tested and found to be in conformity with IEC	<input type="checkbox"/> Additional Information on page 2	
National differences	IEC 61000-6-2:2016 IEC 61000-6-4:2006, IEC 61000-6-4:2006/AMD1:2010 IEC 61000-6-7:2014	
As shown in the Test Report Ref. No. which forms part of this Certificate	EU Group Differences; EU Special National Conditions; EU A-Deviations	
	17-EL-0006.E01 + .E02 + .Z01	



This CB Test Certificate is issued by the National Certification Body

Electrosuisse Luppenstrasse 1 8320 Fehraltorf SWITZERLAND Signed by: Martin Plüss Date: 2017-03-13		 page 1 of 1
---	---	--

13 EU Declaration of Conformity CE-Marking

NTI AG / LinMot®
Bodenaeckerstrasse 2
8957 Spreitenbach

Switzerland

Tel.: +41 (0)56 419 91 91
Fax: +41 (0)56 419 91 92

declares under sole responsibility the compliance of the products:

- Linear modules with carriage series **CF37Sx60-HP-BE01-MD01-N**
- Linear modules with carriage series **CF37Sx60-HP-BE01-MD02-N**
- Linear modules with carriage series **CF37Sx120F-HP-BE01-MD01-N**
- Linear modules with carriage series **CF37Sx120F-HP-BE01-MD02-N**

with the EMC Directive 2014/30/EU.

Applied harmonized standards:

- **EN 61000-6-2: 2005 (Immunity for industrial environments)**
- **EN 61000-6-4: 2007 (Emission for industrial environments)**

According to the EMC directive, the listed devices are not independently operable products.

Compliance of the directive requires the correct installation of the product, the observance of specific installation guides and product documentation. This was tested on specific system configurations.

The safety instructions of the manuals are to be considered.

The product must be mounted and used in strict accordance with the installation instructions contained within the installation guide, a copy of which may be obtained from NTI AG.

Company: NTI AG
Spreitenbach, 29.05.2024



Dr.-Ing. Ronald Rohner
CEO NTI AG

14 UK Declaration of Conformity UKCA-Marking

NTI AG / LinMot®
Bodenaeckerstrasse 2
8957 Spreitenbach

Switzerland

Tel.: +41 (0)56 419 91 91
Fax: +41 (0)56 419 91 92

declares under sole responsibility the compliance of the products:

- Linear modules with carriage series **CF37Sx60-HP-BE01-MD01-N**
- Linear modules with carriage series **CF37Sx60-HP-BE01-MD02-N**
- Linear modules with carriage series **CF37Sx120F-HP-BE01-MD01-N**
- Linear modules with carriage series **CF37Sx120F-HP-BE01-MD02-N**

with the EMC Regulation S.I. 2016 No. 1091.

Applied designated standards:

- **EN 61000-6-2: 2005 (Immunity for industrial environments)**
- **EN 61000-6-4: 2007 (Emission for industrial environments)**

According to the EMC regulation, the listed devices are not independently operable products.

Compliance of the regulation requires the correct installation of the product, the observance of specific installation guides and product documentation. This was tested on specific system configurations.

The safety instructions of the manuals are to be considered.

The product must be mounted and used in strict accordance with the installation instructions contained within the installation guide, a copy of which may be obtained from NTI AG.

Company: NTI AG
Spreitenbach, 29.05.2024



Dr.-Ing. Ronald Rohner
CEO NTI AG

ALL LINEAR MOTION FROM A SINGLE SOURCE

Europe / Asia Headquarters

NTI AG - LinMot & MagSpring

Bodenaeckerstrasse 2
CH-8957 Spreitenbach
Switzerland

Sales / Administration: +41 56 419 91 91
office@linmot.com

Tech. Support: +41 56 544 71 00
support@linmot.com

Web: <https://www.linmot.com/>

Visit <https://linmot.com/contact/> to find a distributor near you.

North / South America Headquarters

LinMot USA Inc.

N1922 State Road 120, Unit 1
Lake Geneva, WI 53147
USA

Sales / Administration: 262.743.2555
usasales@linmot.com

Tech. Support: 262.743.2555
usasupport@linmot.com

Web: <https://www.linmot.com/>