

# LINEAR MOTORS P10-70X160U



- ✓ 3 x 400VAC technology
- ✓ Peak forces up to 1120 N
- ✓ LinMot encoder or 3rd party drive encoder  
BiSS-C, SinCos, AB incremental / Pt 1000, KTY, PTC
- ✓ Extremely high dynamic
- ✓ Separate connector for sensor and power cable
- ✓ Can also be controlled by standard third-party servo drives

## LINEAR MOTORS P10-70X160U

|                                       |            |
|---------------------------------------|------------|
| <b>/ TECHNICAL DATA /</b> .....       | <b>534</b> |
| <b>/ MOTOR SPECIFICATIONS /</b> ..... | <b>548</b> |
| P10-70x160U/90-BL-QJ.....             | 548        |
| P10-70x160U/190-BL-QJ.....            | 549        |
| P10-70x160U/290-BL-QJ.....            | 550        |
| P10-70x160U/390-BL-QJ.....            | 551        |
| P10-70x160U/490-BL-QJ.....            | 552        |
| P10-70x160U/590-BL-QJ.....            | 553        |
| P10-70x160U/690-BL-QJ.....            | 554        |
| P10-70x160U/890-BL-QJ.....            | 555        |
| P10-70x160U/1090-BL-QJ .....          | 556        |
| P10-70x160U/1290-BL-QJ .....          | 557        |
| P10-70x160U/1490-BL-QJ .....          | 558        |
| P10-70x160U/1690-BL-QJ .....          | 559        |
| <b>/ LINEAR GUIDES /</b> .....        | <b>560</b> |
| <b>/ ACCESSORIES /</b> .....          | <b>562</b> |



## MOTOR FAMILY P10-70x160U

### Technical Data

| Stroke  |  |  |                                |
|---|--|--|--------------------------------|
| Max. Stroke (ES)                                      | mm (in)  |  | 1690 (66.49)                   |
| Force   |  |  |                                |
| Max. Force <sup>1</sup> @ 1x230VAC                    | N (lbf)  |  | 1120 (252)                     |
| Max. Force <sup>1</sup> @ 3x400VAC                    | N (lbf)  |  | 1120 (252)                     |
| Max. Cont. Force [Passive cooling / Fan / Fluid]      | N (lbf)  |  | 130 / 200 / 350 (29 / 45 / 79) |
| Max. Border Force relative                            | %  |  | 100                            |
| Force Constant 1                                      | N/A <sub>pk</sub> (lbf/A <sub>pk</sub> )           |  | 56 (12.6)                      |
| Force Constant 2                                      | N/A <sub>rms</sub> (lbf/A <sub>rms</sub> )         |  | 79.2 (17.8)                    |
| Velocity  |  |  |                                |
| Max. Velocity @ 1x230VAC                              | m/s (in/s)   |  | 3.2 (129.9)                    |
| Max. Velocity @ 3x400VAC                              | m/s (in/s)   |  | 5.6 (219.9)                    |
| Position Detection                                    |  |  |                                |
| Position Resolution                                   | mm (in)  |  | 0.005 (0.0002)                 |
| Repeatability   | mm (in)  |  | ±0.05 (±0.002)                 |
| Position Resolution with ES                           | mm (in)  |  | 0.001 (0.00004)                |
| Repeatability with ES                                 | mm (in)  |  | ±0.01 (±0.0004)                |
| Linearity with ES                                     | mm (in)  |  | ±0.01 (±0.0004)                |
| Electrical Data                                       |  |  |                                |
| Max. Current <sup>1</sup> @ 1x230VAC                  | A <sub>pk</sub> / A <sub>rms</sub>                 |  | 19.9 / 14                      |
| Max. Current <sup>1</sup> @ 3x400VAC                  | A <sub>pk</sub> / A <sub>rms</sub>                 |  | 19.9 / 14                      |
| Max. Cont. Current 1 [Passive cooling / Fan / Fluid]  | A <sub>pk</sub>                                    |  | 2.3 / 3.6 / 6.3                |
| Max. Cont. Current 2 [Passive cooling / Fan / Fluid]  | A <sub>rms</sub>                                   |  | 1.7 / 2.5 / 4.4                |
| Back EMF Constant                                     | V <sub>pk</sub> / (m/s)   V <sub>pk</sub> / (in/s) |  | 64.7 (1.64)                    |
| Terminal Resistance 25 °C / 120 °C                    | Ohm  |  | 8.3 / 11                       |
| Terminal Inductivity                                  | mH   |  | 16                             |
| Magnetic Period                                       | mm (in)  |  | 40 (1.57)                      |
| Thermal Data  |  |  |                                |
| Max. Winding Temperature (Sensor)                     | °C   |  | 90                             |
| Thermal Resistance [Passive cooling / Fan / Fluid]    | °K/W   |  | 1.3 / 0.56 / 0.18              |
| Thermal Time Constant [Passive cooling / Fan / Fluid] | s  |  | 2100 / 500 / 110               |
| Mechanical Data                                       |  |  |                                |
| Stator Diameter                                       | mm (in)  |  | 70 (2.8)                       |
| Stator Length   | mm (in)  |  | 260 (10)                       |
| Stator Mass   | g (lb)   |  | 4200 (9.24)                    |
| Slider Diameter                                       | mm (in)  |  | 28 (1.1)                       |
| Slider Length   | mm (in)  |  | 390 - 1990 (15 - 78)           |
| Slider Mass   | g (lb)   |  | 1830 - 9350 (4.03 - 20.57)     |
| IP Code   |  |  | IP 65                          |
| Certification   |  |  |                                |
| UL  | File-No.   |  | E354430                        |

<sup>1</sup> Real time calculation of motor winding temperature is required (including monitoring).

If temperature monitoring is only based on temperature sensor signal (missing thermal model calculation), 60 % of the peak value has to be taken instead.

**STATOR**

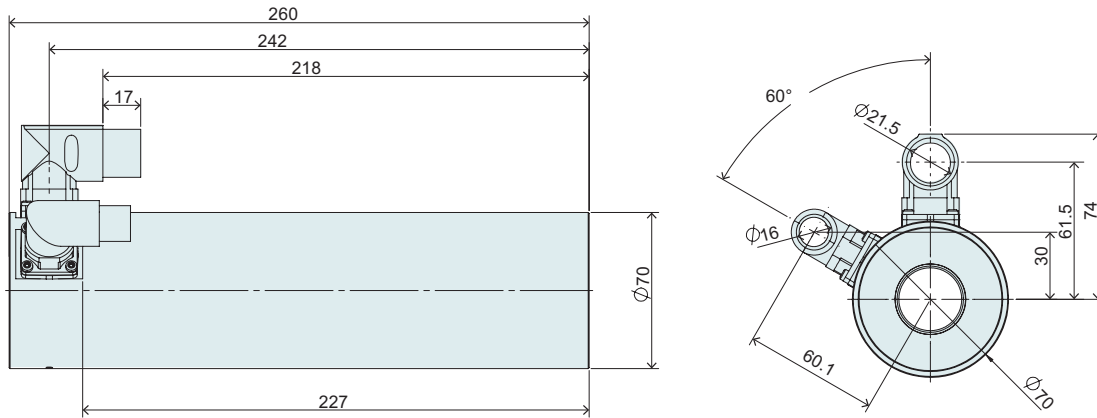

| Item                           | Description  | Item-No.                  | Comment                       |
|--------------------------------|--|---------------------------|-------------------------------|
| <b>PS10-70x160U-BL-QJ</b>      | Stator 3x400VAC, LinMot Encoder                    | <a href="#">0150-1292</a> | For use with LinMot Drives    |
| <b>PS10-70x160U-BL-QJ-D04</b>  | Stator 3x400VAC, Sin/Cos Encoder 1Vpp, Pt1000 dual | <a href="#">0150-4261</a> | For use with 3rd Party Drives |
| <b>PS10-70x160U-BL-QJ-D05</b>  | Stator 3x400VAC, Sin/Cos Encoder 1Vpp, PTC dual    | <a href="#">0150-4606</a> | For use with 3rd Party Drives |
| <b>PS10-70x160U-BL-QJ-D08</b>  | Stator 3x400VAC, Sin/Cos Encoder 1Vpp, KTY dual    | <a href="#">0150-4511</a> | For use with 3rd Party Drives |
| <b>PS10-70x160U-BL-QJ-D24</b>  | Stator 3x400VAC, A/B Encoder 1µm, Pt1000 dual      | <a href="#">0150-4131</a> | For use with 3rd Party Drives |
| <b>PS10-70x160U-BL-QJ-D24S</b> | Stator 3x400VAC, A/B Encoder 5µm, Pt1000 dual      | <a href="#">0150-4596</a> | For use with 3rd Party Drives |
| <b>PS10-70x160U-BL-QJ-D25</b>  | Stator 3x400VAC, A/B Encoder 1µm, PTC dual         | <a href="#">0150-5761</a> | For use with 3rd Party Drives |
| <b>PS10-70x160U-BL-QJ-D25S</b> | Stator 3x400VAC, A/B Encoder 5µm, PTC dual         | <a href="#">0150-4601</a> | For use with 3rd Party Drives |
| <b>PS10-70x160U-BL-QJ-D26</b>  | Stator 3x400VAC, A/B Encoder 1µm, PTC single ended | <a href="#">0150-4515</a> | For use with 3rd Party Drives |
| <b>PS10-70x160U-BL-QJ-D34</b>  | Stator 3x400VAC, BiSS-C, Pt1000 dual               | <a href="#">0150-4871</a> | For use with 3rd Party Drives |

**AVAILABLE INTERFACES FOR 3RD PARTY DRIVES**

| TEMPERATURE FEEDBACK |     | POSITION FEEDBACK |            |             |            |
|----------------------|-----|-------------------|------------|-------------|------------|
|                      |     | SinCos, 1Vpp      | A/B 1µm    | A/B 5µm     | BiSS-C     |
|                      |     | D0x               | D2x        | D2xS        | D3x        |
| Pt1000, dual*        | Dx4 | <b>D04</b>        | <b>D24</b> | <b>D24S</b> | <b>D34</b> |
| PTC, dual*           | Dx5 | <b>D05</b>        | <b>D25</b> | <b>D25S</b> |            |
| PTC single ended     | Dx6 |                   | <b>D26</b> |             |            |
| KTY, dual*           | Dx8 | <b>D08</b>        |            |             |            |

\* Feedback available on encoder and power connectors.

**CONNECTOR PS10-70x160U-BL-QJ (INTERFACE FOR LINMOT DRIVES)**

4

| Motor Connector Wiring |               | Connector Encoder J | Wire Color Cable KSS05-02/08 |
|------------------------|---------------|---------------------|------------------------------|
| +5VDC*                 | Supply        | 1                   | red                          |
| GND                    | Supply        | 2                   | black                        |
| Sense +5V*             | Supply Sense  | 3                   | white                        |
| Sense GND*             | Supply Sense  | 4                   | brown                        |
| Mot. Link C+           | Communication | 5                   | pink                         |
| Mot. Link C-           | Communication | 6                   | grey                         |
| Sin+                   | Encoder       | 7                   | yellow                       |
| Sin-                   | Encoder       | 8                   | orange                       |
| Cos+                   | Encoder       | 9                   | green                        |
| Cos-                   | Encoder       | 10                  | blue                         |
| n. c.                  | n. c.         | 11                  | n. c.                        |
| n. c.                  | n. c.         | 12                  | n. c.                        |
| n. c.                  | n. c.         | 13                  | n. c.                        |
| n. c.                  | n. c.         | 14                  | n. c.                        |
| n. c.                  | n. c.         | 15                  | n. c.                        |
| n. c.                  | n. c.         | 16                  | n. c.                        |
| n. c.                  | n. c.         | 17                  | n. c.                        |

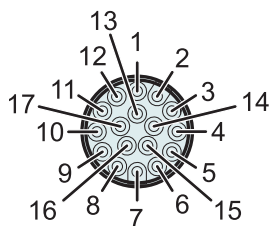

**Connector Encoder J**

View: Motor connector, plug side

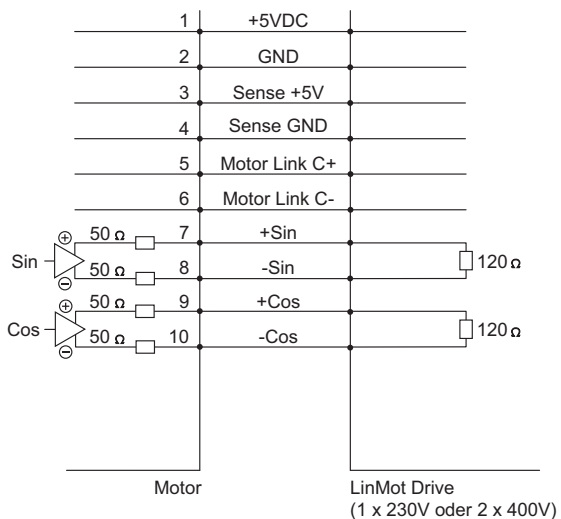

\* The supply voltage at 5V sense supply is approx. 6V. Newer motors are provided with a modified power supply, that does not require sense lines any more. In that case, a supply voltage of 6...9V is permitted.

| Motor Connector Wiring | Connector Power Q | Wire Color Cable KPS15-04 |
|------------------------|-------------------|---------------------------|
| Phase U                | 1                 | red                       |
| PE                     | 2                 | yellow-green              |
| Phase W                | 3                 | black (previously: green) |
| Phase V                | 4                 | blue                      |
| n. c.                  | A                 | n. c.                     |
| n. c.                  | B                 | n. c.                     |
| n. c.                  | C                 | n. c.                     |
| n. c.                  | D                 | n. c.                     |

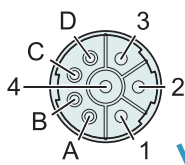

**Connector Power Q**

View: Motor connector, plug side

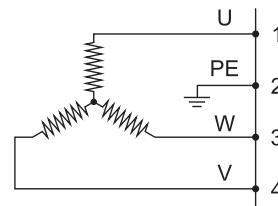

**SIN/COS-POSITIONS-FEEDBACK (D0X-INTERFACE FOR 3RD PARTY DRIVES)**

The linear motors of the P10-70 series have a contactless, integrated position feedback, which means that an external encoder is not required. The integrated position sensor technology of the motors with D0x interface provides a differential standard 1Vpp sin/cos signal with a 40mm period. The phase position of the sensor signals and the phase currents (with constant force in positive direction) is shown on the right side of the diagram. (The SIN encoder signal is in phase with the current characteristic of phase U).

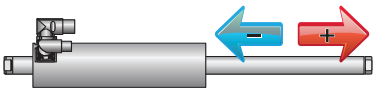

The arrows show the direction of movement of the slider. The stator remains in its position.

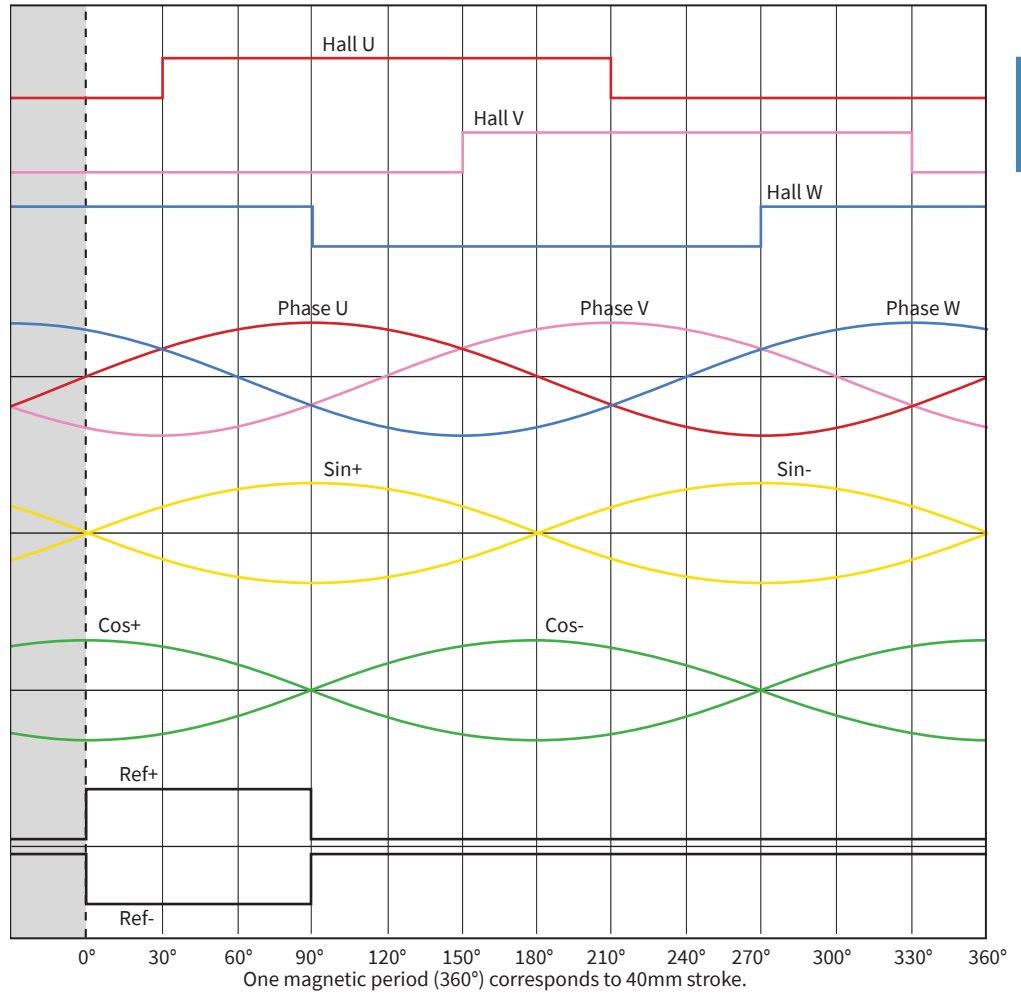

| Sin / Cos                     |                 | P10-70x...-D0x                                     |
|-------------------------------|-----------------|--|
| Output signal period          | mm              | 40   |
| Signal amplitude <sup>1</sup> | V <sub>pp</sub> | 1  |
| Termination <sup>1</sup>      | Ohm             | 120  |
| Supply voltage                | Vdc             | 3...13 (w or w/o sense)                            |
| Power consumption             | mW              | < 1000   |
|                               |                 | (I < 150mA @ 5VDC, I < 80mA @ 12 VDC) <sup>2</sup> |

1) Applicable for Sin+/Sin-, Cos+/Cos- and Ref+/Ref- signals. Hall U/V/W are open collector signals.  
 2) Power efficiency of the motor electronics varies with supply voltage

**CONNECTOR PS10-70X160U-BL-QJ-D04/05/08 (SIN/COS-INTERFACE FOR 3RD PARTY DRIVES)**

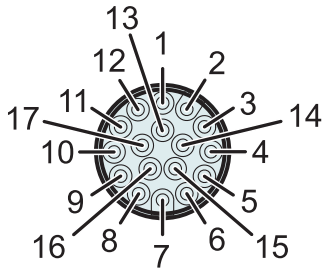

3 ... 13VDC  
 (I<sub>max</sub> < 150mA @ 5VDC)  
 (I<sub>max</sub> < 80mA @ 12VDC)

**Connector Encoder J**

View: Motor connector, plug side

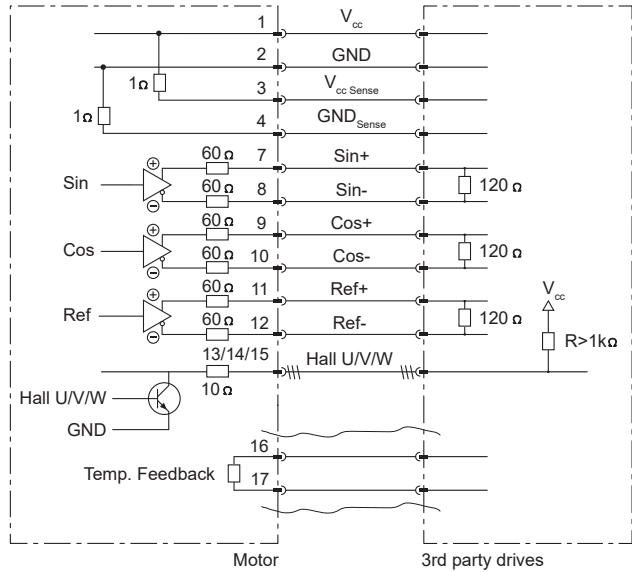

**PS10-70X160U-BL-QJ-D04**

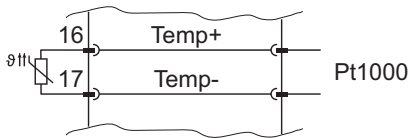

**PS10-70X160U-BL-QJ-D05**

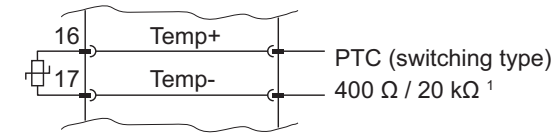

1) ≤ 400 Ω = no error, ≥ 20 kΩ = error

**PS10-70X160U-BL-QJ-D08**

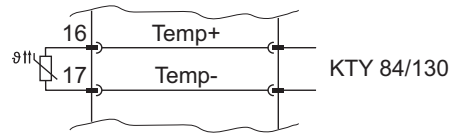

| Sin/Cos-Interface: Encoder Connector Wiring |   |                                       |                     |                                    |                                    |
|---|---|---------------------------------------|---------------------|------------------------------------|------------------------------------|
| PS10-70x160U-BL-QJ-D04                      | PS10-70x160U-BL-QJ-D05                  | PS10-70x160U-BL-QJ-D08                | Connector Encoder J | Wire Color Motor Cable KSS05-02/06 | Wire Color Motor Cable KSS05-02/13 |
|   | 3 ... 13VDC                             |                                       | 1                   | red                                | white                              |
|   | GND                                     |                                       | 2                   | black                              | brown                              |
|   | V <sub>cc</sub> Sense (optional)        |                                       | 3                   | white                              | green                              |
|   | GND Sense (optional)                    |                                       | 4                   | brown                              | yellow                             |
|   | Do not connect                          |                                       | 5                   | -                                  | -                                  |
|   | Do not connect                          |                                       | 6                   | -                                  | -                                  |
|   | Sin+                                    |                                       | 7                   | yellow                             | grey                               |
|   | Sin-                                    |                                       | 8                   | orange                             | pink                               |
|   | Cos+                                    |                                       | 9                   | green                              | blue                               |
|   | Cos-                                    |                                       | 10                  | blue                               | red                                |
|   | Ref+                                    |                                       | 11                  | -                                  | black                              |
|   | Ref-                                    |                                       | 12                  | -                                  | purple                             |
|   | Hall U                                  |                                       | 13                  | -                                  | grey-red                           |
|   | Hall V                                  |                                       | 14                  | -                                  | red-blue                           |
|   | Hall W                                  |                                       | 15                  | -                                  | white-green                        |
| Temp+ (Pt1000 Char.) <sup>2)</sup>          | Temp+ (PTC 400/20k Char.) <sup>2)</sup> | Temp+ (KTY84/130 Char.) <sup>2)</sup> | 16                  | -                                  | yellow-brown                       |
| Temp- (Pt1000 Char.) <sup>2)</sup>          | Temp- (PTC 400/20k Char.) <sup>2)</sup> | Temp- (KTY84/130 Char.) <sup>2)</sup> | 17                  | -                                  | white-yellow                       |

2) The temperature evaluation circuit must have the same galvanic reference potential as the encoder circuit (supply). It should therefore be connected to the supply GND. For correct evaluation, the connection potentials of the emulated temperature sensor must be in the range of the supply potentials. Valid temperature values can only be measured 50ms after the encoder supply is applied. In the currentless state, a resistance of 200kOhm is measured between pin 16 and 17 is measured. The maximum voltage between pin 16 and 17 must not exceed 16VDC. The maximum current is 15mA.

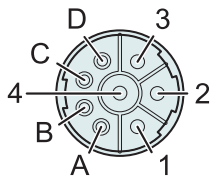

**Connector Power Q**  
View: Motor connector, plug side

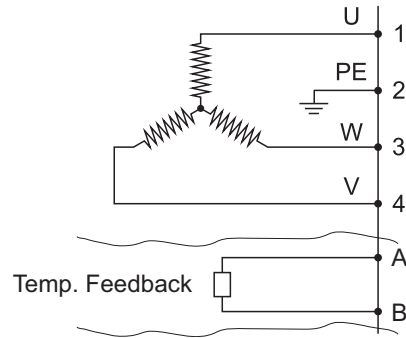

**PS10-70X160U-BL-QJ-D04**

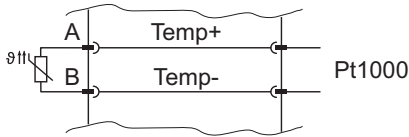

**PS10-70X160U-BL-QJ-D05**

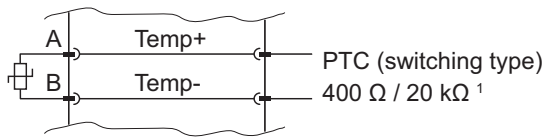

**PS10-70X160U-BL-QJ-D08**

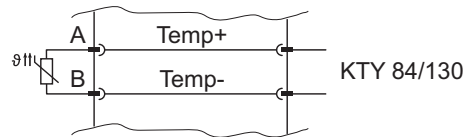

1)  $\leq 400 \Omega$  = no error,  $\geq 20 \text{ k}\Omega$  = error

| Sin/Cos-Interface: Power Connector Wiring |                           |                                       |                   |                                 |                                    |
|---|---------------------------|---------------------------------------|-------------------|---------------------------------|------------------------------------|
| PS10-70x160U-BL-QJ-D04                    | PS10-70x160U-BL-QJ-D05    | PS10-70x160U-BL-QJ-D08                | Connector Power Q | Wire Color Motor Cable KPS15-04 | Wire Color Motor Cable KPS15-04/04 |
| Phase U                                   |                           |                                       | 1                 | red                             | red                                |
| PE  |                           |                                       | 2                 | yellow-green                    | yellow-green                       |
| Phase W                                   |                           |                                       | 3                 | black                           | black                              |
| Phase V                                   |                           |                                       | 4                 | blue                            | blue                               |
| Temp+ (Pt1000) <sup>2)</sup>              | Temp+ (PTC) <sup>2)</sup> | Temp+ (KTY84/130 Char.) <sup>2)</sup> | A                 | n. c.                           | purple                             |
| Temp- (Pt1000) <sup>2)</sup>              | Temp- (PTC) <sup>2)</sup> | Temp- (KTY84/130 Char.) <sup>2)</sup> | B                 | n. c.                           | grey                               |
| n. c.                                     | n. c.                     | n. c.                                 | C                 | n. c.                           | yellow                             |
| n. c.                                     | n. c.                     | n. c.                                 | D                 | n. c.                           | brown                              |

2) The temperature evaluation circuit must have the same galvanic reference potential as the encoder circuit (supply). It should therefore be connected to the supply GND. For correct evaluation, the connection potentials of the emulated temperature sensor must be in the range of the supply potentials. Valid temperature values can only be measured 50ms after the encoder supply is applied. In currentless state a resistance of 200kOhm is measured between pin A and B. The maximum voltage between pin A and B must not exceed 16VDC. The maximum current is 15mA.

**TEMPERATURE FEEDBACK D04 / D05 / D08**

Overheating protection is provided by three internal thermistors embedded in the motor windings. These thermistors are monitored by the motor electronics. A single thermistor is simulated based on the maximum temperature readings. This is done in order to accurately monitor the temperature over the entire length of the stator and to respond as quickly as possible to dynamic changes in a single motor phase. When the temperature of the motor winding reaches its absolute maximum value, the drive amplifier/servo controller must switch off the motor to protect it from overheating damage. Various temperature interfaces – Dx4, Dx5 or Dx8 – are available to support

the temperature evaluation provided by the drive amplifier/servo controller. Depending on the interface and signals used, there are suitable motor cables (see overview table in the Accessories/Motor Cables section).

**D04 (Pt1000 dual)**

Both the **signal** and **power connectors** feature an emulated **Pt1000 thermistor** for evaluating the maximum motor temperature.

**D05 (PTC dual)**

Both the **signal** and **power connectors** are fitted with an emulated **PTC thermistor** that switches to high-impedance mode when the maximum motor temperature is exceeded.

**D08 (KTY 84/130 dual)**

Both the **signal** and **power connectors** feature an emulated **KTY thermistor**, which is used to evaluate the maximum motor temperature.

**A/B INCREMENTAL POSITION FEEDBACK (D2X- INTERFACE FOR 3RD PARTY DRIVES)**

4

The linear motors of the P10-70 series have a contactless, integrated position feedback, which means that an external encoder is not required.

The position output of the motors with D2x interface is an industry-standard A/B incremental signal with supplementary reference signal (RS422). Hall switch signals are available for commutation. The relationship between the phase current and the position sensor output is shown on the right.

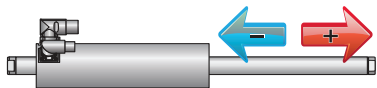

The arrows show the direction of movement of the slider. The stator remains in its position.

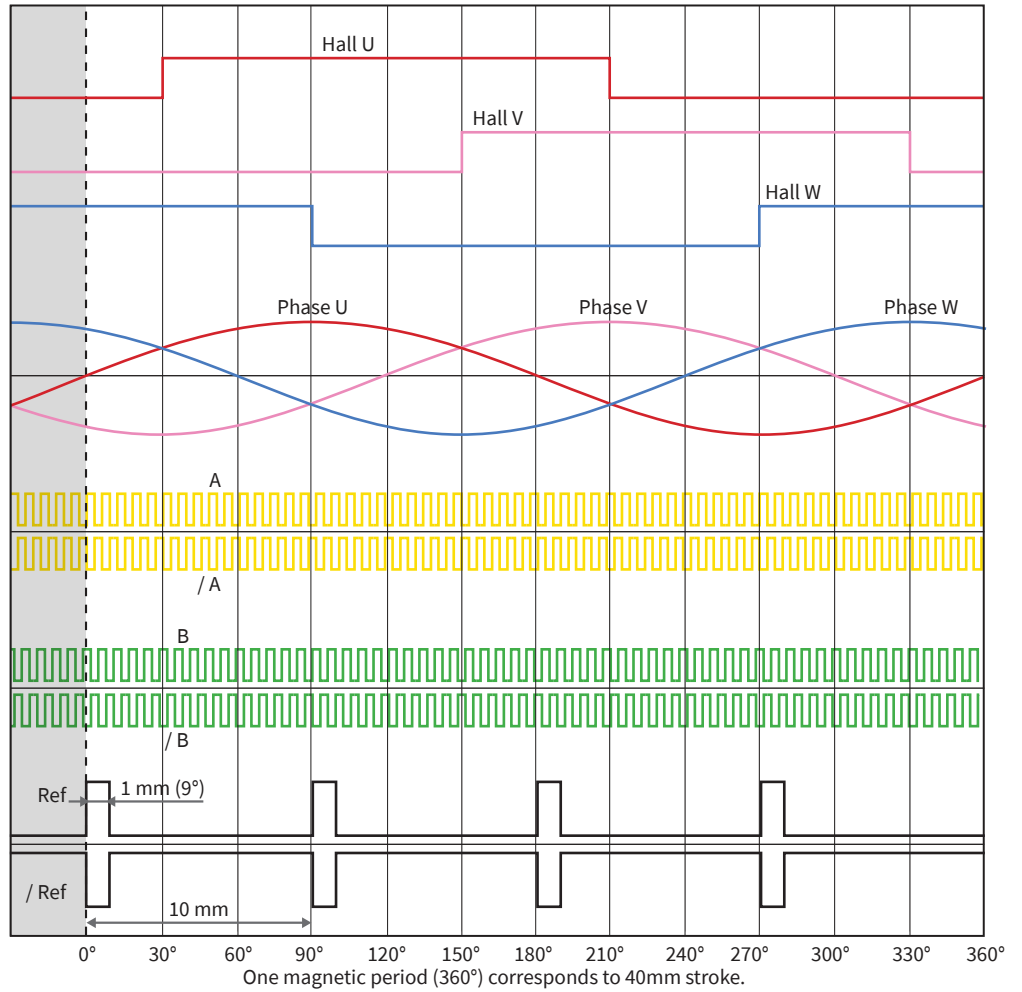

Example:  
 Min. pulse interval  $t = 500 \text{ ns}$   
 For downstream evaluation, at least the following counter frequency is required:  
 $f_{\text{counter}} = 1 / \text{pulse interval}$   
 $= 1 / 500 \text{ ns} = 2 \text{ MHz}$



The logical state of signals A and B is not defined in relation to the reference signal Ref. The signal shape may differ from the illustration.

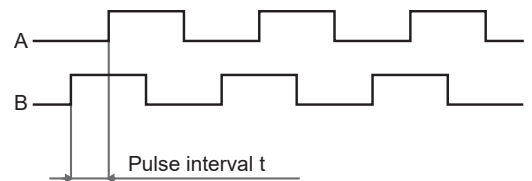

| A / B                           |     | P10-70x...-D2x | P10-70x...-D2xS |
|---------------------------------|-----|----------------|-----------------|
| Position Resolution             | μm  | 1              | 5               |
| Output Type                     |     | RS422          |                 |
| Min. Edge Distance t            | ns  | 100            | 500             |
| Min. required counter frequency | MHz | 10             | 2               |
| Supply Voltage                  | Vdc | 5-12           |                 |
| Max. Supply Current             | mA  | 300            | 300             |

**CONNECTOR PS10-70X160U-BL-QJ-D24 / D24S / 25 / 25S / 26 (A/B-INTERFACE FOR 3RD PARTY DRIVES)**

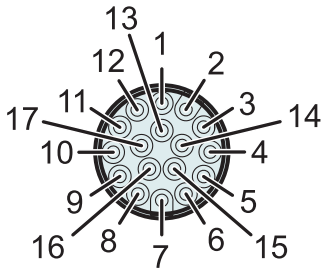

3 ... 13VDC  
 (Imax < 150mA @ 5VDC)  
 (Imax < 80mA @ 12VDC)

**Connector Encoder J**

View: Motor connector, plug side

**PS10-70X160U-BL-QJ-D24 / D24S**

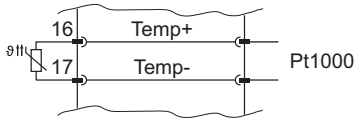

**PS10-70X160U-BL-QJ-D25 / D25S**

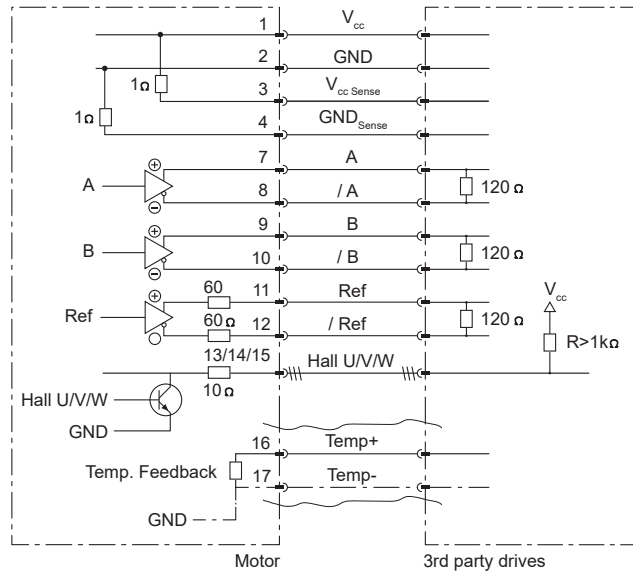
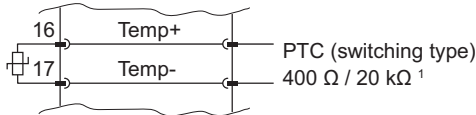

**PS10-70X160U-BL-QJ-D26**

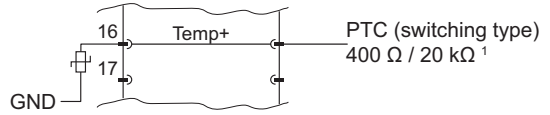

1) ≤ 400 Ω = no error, ≥ 20 kΩ = error

| A/B-Interface: Encoder Connector Wiring           |   |   |                        |                                       |                                       |  |
|---|---|---|------------------------|---------------------------------------|---------------------------------------|--|
| PS10-70x160U-BL-QJ-D24<br>PS10-70x160U-BL-QJ-D24S | PS10-70x160U-BL-QJ-D25<br>PS10-70x160U-BL-QJ-D25S | PS10-70x160U-BL-QJ-D26                  | Connector<br>Encoder J | Wire Color Motor Cable<br>KSS05-02/06 | Wire Color Motor Cable<br>KSS05-02/13 |  |
|   | 3 ... 13VDC                                       |   | 1                      | red                                   | white                                 |  |
|   | GND   |   | 2                      | black                                 | brown                                 |  |
|   | Vcc Sense (optional)                              |   | 3                      | white                                 | green                                 |  |
|   | GND Sense (optional)                              |   | 4                      | brown                                 | yellow                                |  |
|   | Do not connect                                    |   | 5                      | -                                     | -                                     |  |
|   | Do not connect                                    |   | 6                      | -                                     | -                                     |  |
|   | A   |   | 7                      | yellow                                | grey                                  |  |
|   | /A  |   | 8                      | orange                                | pink                                  |  |
|   | B   |   | 9                      | green                                 | blue                                  |  |
|   | /B  |   | 10                     | blue                                  | red                                   |  |
|   | Ref   |   | 11                     | -                                     | black                                 |  |
|   | /Ref  |   | 12                     | -                                     | purple                                |  |
|   | Hall U  |   | 13                     | -                                     | grey-red                              |  |
|   | Hall V  |   | 14                     | -                                     | red-blue                              |  |
|   | Hall W  |   | 15                     | -                                     | white-green                           |  |
| Temp+ (Pt1000 Char.) <sup>2)</sup>                | Temp+ (PTC 400/20k Char.) <sup>2)</sup>           | Temp+ (PTC 400/20k Char.) <sup>2)</sup> | 16                     | -                                     | yellow-brown                          |  |
| Temp- (Pt1000 Char.) <sup>2)</sup>                | Temp- (PTC 400/20k Char.) <sup>2)</sup>           | Do not connect                          | 17                     | -                                     | white-yellow                          |  |

2) The temperature evaluation circuit must have the same galvanic reference potential as the encoder circuit (supply). It should therefore be connected to the supply GND. For correct evaluation, the connection potentials of the emulated temperature sensor must be in the range of the supply potentials. Valid temperature values can only be measured 50ms after the encoder supply is applied. In the currentless state, a resistance of 200kOhm is measured between pin 16 and 17 is measured. The maximum voltage between pin 16 and 17 must not exceed 16VDC. The maximum current is 15mA.

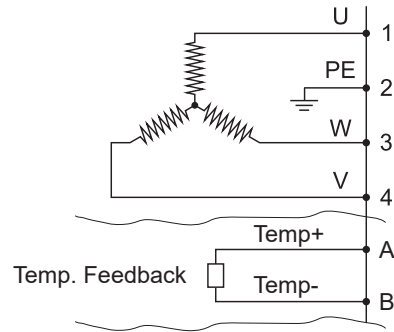
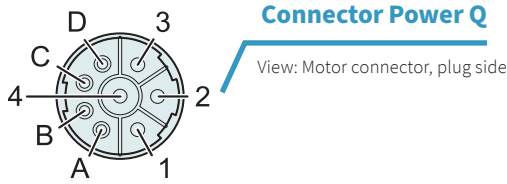

**PS10-70X160U-BL-QJ-D24 / D24S**

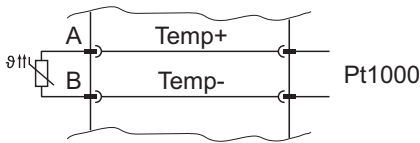

**PS10-70X160U-BL-QJ-D25 / D25S**

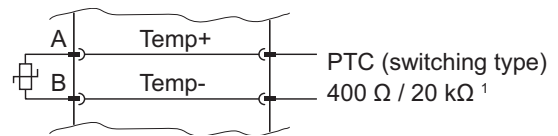

1) unter 400 Ω = no error, über 20 kΩ = error

| A/B-Interface: Power Connector Wiring             |   |                        |                   |                                    |                                       |
|---|---|------------------------|-------------------|------------------------------------|---------------------------------------|
| PS10-70x160U-BL-QJ-D24<br>PS10-70x160U-BL-QJ-D24S | PS10-70x160U-BL-QJ-D25<br>PS10-70x160U-BL-QJ-D25S | PS10-70x160U-BL-QJ-D26 | Connector Power Q | Wire Color Motor Cable<br>KPS15-04 | Wire Color Motor Cable<br>KPS15-04/04 |
| Phase U   |   |                        | 1                 | red                                | red                                   |
| PE  |   |                        | 2                 | yellow-green                       | yellow-green                          |
| Phase W   |   |                        | 3                 | black                              | black                                 |
| Phase V   |   |                        | 4                 | blue                               | blue                                  |
| Temp+ (Pt1000) <sup>2)</sup>                      | Temp+ (PTC) <sup>2)</sup>                         | n. c.                  | A                 | n. c.                              | purple                                |
| Temp- (Pt1000) <sup>2)</sup>                      | Temp- (PTC) <sup>2)</sup>                         | n. c.                  | B                 | n. c.                              | grey                                  |
| n. c.   | n. c.   | n. c.                  | C                 | n. c.                              | yellow                                |
| n. c.   | n. c.   | n. c.                  | D                 | n. c.                              | brown                                 |

2) The temperature evaluation circuit must have the same galvanic reference potential as the encoder circuit (supply). It should therefore be connected to the supply GND. For correct evaluation, the connection potentials of the emulated temperature sensor must be in the range of the supply potentials. Valid temperature values can only be measured 50ms after the encoder supply is applied. In currentless state a resistance of 200kOhm is measured between pin A and B. The maximum voltage between pin A and B must not exceed 16VDC. The maximum current is 15mA.

**TEMPERATURE FEEDBACK D24 / D24S / D25 / D25S / D26**

Overheating protection is provided by three internal thermistors embedded in the motor windings. These thermistors are monitored by the motor electronics. A single thermistor is simulated based on the maximum temperature readings. This is done in order to accurately monitor the temperature over the entire length of the stator and to respond as quickly as possible to dynamic changes in a single motor phase. If the temperature of the motor winding reaches its absolute maximum value, the drive amplifier/servo controller must switch off the motor to protect it from overheating damage. Various temperature interfaces – DX4, DX5 or DX6 – are available to support the temperature evaluation provided by the

drive amplifier/servo controller. Depending on the interface and signals used, there are suitable motor cables (see overview table in the Accessories/Motor Cables section).

**D24 / D24S (Pt1000 dual)**

An emulated **Pt1000 thermistor** is available on both the **signal** and **power connectors** for evaluating the maximum motor temperature.

**D25 / D25S (PTC dual)**

An emulated **PTC thermistor** is available on both the **signal** and **power connectors**, which switches to a high-impedance state when the maximum motor temperature is exceeded.

**D26 (PTC)**

An emulated PTC thermistor is available on the **signal connector**, which switches to a high-impedance state when the maximum motor temperature is exceeded. The emulated **PTC** is internally **connected to GND on one side**, which is why only an additional signal line is connected to the servo controller for evaluation in addition to the power supply.

**BISS-C POSITION FEEDBACK (D3X- INTERFACE FOR 3RD PARTY DRIVES)**

The linear motors of the P10-70 series have contactless, integrated position feedback, which means that there is no need for an external encoder.

The position feedback of the motors with D3x interface is based on RS422 and the industry-standard BiSS-C protocol. Either the transmitted position or the hall switch signals can be used for commutation. The relationship between the phase current and the encoder signals is shown on the right.

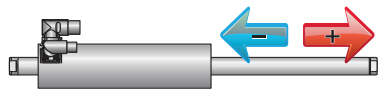

The arrows show the direction of movement of the slider. The stator remains in its position.

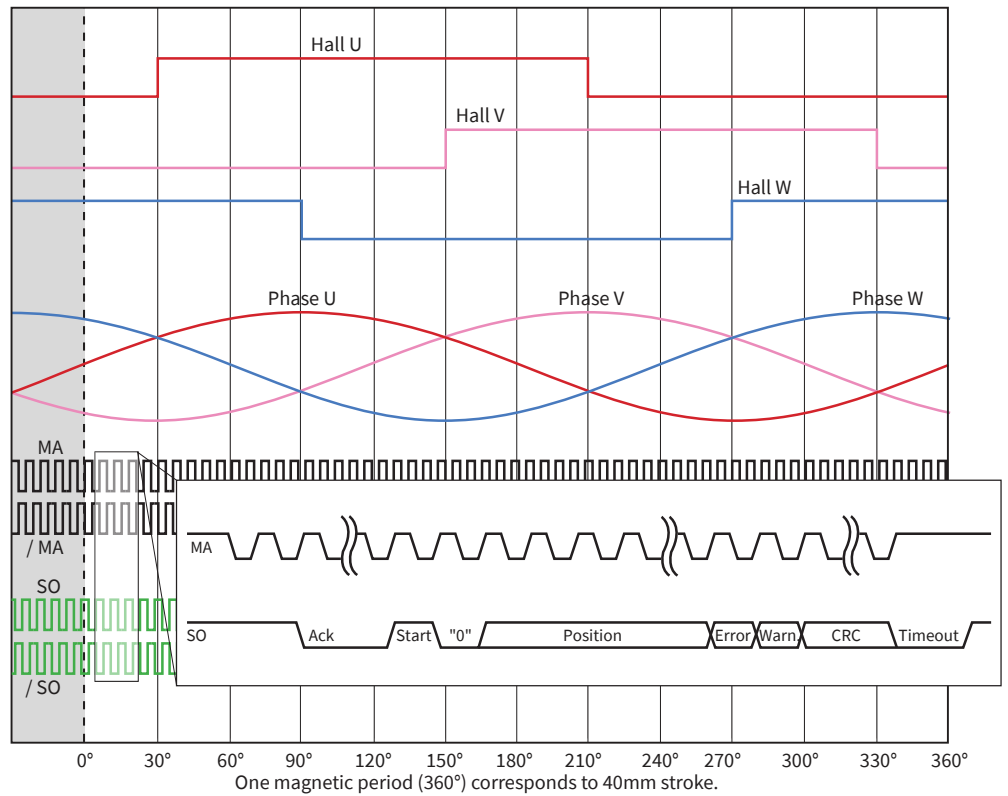

| BiSS-C <sup>1)</sup>                  | P10-70x...-D3x |   |     |     |
|---------------------------------------|----------------|---|-----|-----|
| Singleturn Position Resolution        | µm             | 1   |     |     |
| Output Type                           |                | RS422   |     |     |
| MA Clock frequency                    | MHz            | 1...3.3   |     |     |
| Max. request cycle rate <sup>2)</sup> | kHz            | 16  |     |     |
| Supply Voltage                        | Vdc            | 5 -12   |     |     |
| Max. Supply Current                   | mA             | 300   |     |     |
| Data Type                             |                | SCDS (Single Cycle Data Sensor)   |     |     |
| Data (Bits)                           |                | Position  | nER | nWA |
|                                       |                | Singleturn  | 1   | 1   |
|                                       |                | 34  |     |     |
| Data Format and Alignment             |                | Binary coded, MSB first, right aligned  |     |     |
| CRC polynomial                        |                | 0x43 (X <sup>6</sup> + X <sup>1</sup> + X <sup>0</sup> ) – CRC bit length 6 bits, CRC is inverted |     |     |
| CRC Starting Value                    |                | 0x00  |     |     |
| BiSS Timeout (tm)                     | µs             | ~20   |     |     |
| Switch-on Delay                       | ms             | 100   |     |     |

1) Compatible with bidirectional interfaces supporting EDS register access and unidirectional interfaces  
 2) Achievable only if the data transmission time is shorter than one request cycle. Recommended MA Clock frequency 2MHz.

**Commutation Angle**

$$\text{Commutation Angle} = (\text{Position mod magnetic Period}) \cdot \frac{360^\circ}{\text{Magnetic Period}}$$

First, the position data is reduced to the range within a magnetic period using modulo.

This relative position value is then converted into an electrical angle.

**BISS-C-FRAME DESCRIPTION**

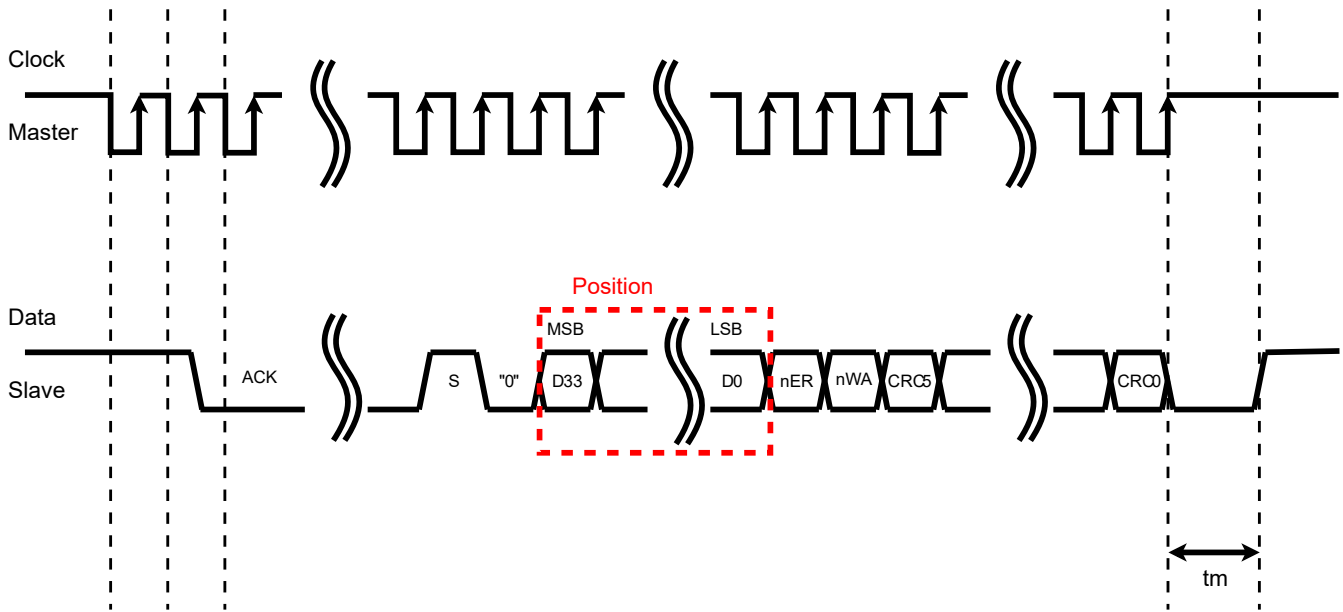

**Singleturn Position 34 Bit: D33-D0**

Binary coded, MSB first  
 Resolution per bit = 1  $\mu$ m  
 After switching on the encoder, the position starts with an offset of 3 m. In addition to the offset, the current position angle of the slider within a pole pair (magnetic period) of the motor is added to this. This position can be used for commutation.

**Errorbit: nER**

0: error; 1: no error (active low).  
 Indicates an encoder error. If this bit indicates an error, the position must be treated as invalid.

**Warnbit: nWA**

0: warning; 1: no warning (active low).  
 Displays encoder warnings. The position is still valid if only a warning is displayed.

**CRC 6 Bit: CRC5-0**

Polynomial : 0x43  
 Initial value : 0x00  
 The CRC is calculated via position, error and warning bits.  
 It is transmitted with MSB first and inverted. The start bit and the "0" bit are omitted from the CRC calculation.

**Register and Memory Definitions**

A description of how a BiSS-C master can access registers can be found at [www.biss-interface.com](http://www.biss-interface.com).

**BiSS-C - XML**

The encoder is compatible with the "Standard Encoder Profile (BP3)".  
 The function of the XML file is to automatically assign device properties in the master using the BiSS identifier.  
 The XML file can be used by masters to facilitate the configuration of slave devices. It can be downloaded from [www.linmot.com](http://www.linmot.com).

**CONNECTOR PS10-70X160U-BL-QJ-D34 (BISS-C INTERFACE FOR 3RD PARTY DRIVES)**

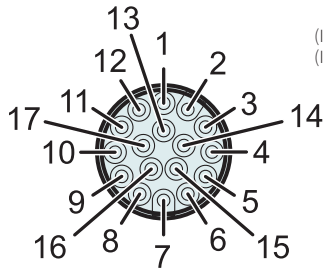

3 ... 13VDC  
 (I<sub>max</sub> < 150mA @ 5VDC)  
 (I<sub>max</sub> < 80mA @ 12VDC)

**Connector Encoder J**

View: Motor connector, plug side

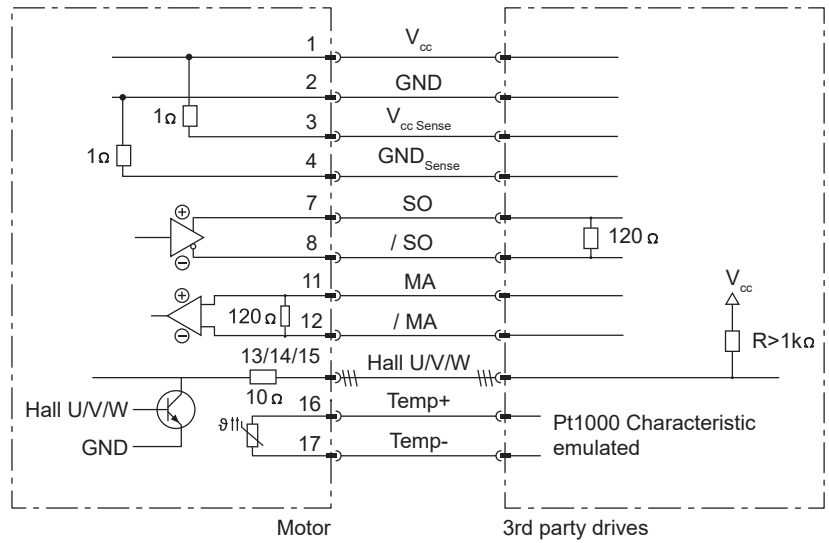

| BiSS-C-Interface: Encoder Connector Wiring |                          |                     |                                    |
|--|--------------------------|---------------------|------------------------------------|
| PS10-70x160U-BL-QJ-D34                     | Function                 | Connector Encoder J | Wire Color Motor Cable KSS05-02/13 |
| 3 ... 13VDC                                | Supply                   | 1                   | white                              |
| GND  | Supply                   | 2                   | brown                              |
| Vcc Sense (optional)                       | Supply Sense             | 3                   | green                              |
| GND Sense (optional)                       | Supply Sense             | 4                   | yellow                             |
| Do not connect                             | -                        | 5                   | -                                  |
| Do not connect                             | -                        | 6                   | -                                  |
| SO (Slave out)                             | Encoder RS422            | 7                   | grey                               |
| / SO (Slave out)                           | Encoder RS422            | 8                   | pink                               |
| Do not connect                             | -                        | 9                   | blue                               |
| Do not connect                             | -                        | 10                  | red                                |
| MA (Master clock)                          | Encoder RS422            | 11                  | black                              |
| / MA (Master clock)                        | Encoder RS422            | 12                  | purple                             |
| Hall U                                     | Encoder (open collector) | 13                  | grey-red                           |
| Hall V                                     | Encoder (open collector) | 14                  | red-blue                           |
| Hall W                                     | Encoder (open collector) | 15                  | white-green                        |
| Temp+ (Pt1000)                             | Temperature <sup>1</sup> | 16                  | yellow-brown                       |
| Temp- (Pt1000)                             | Temperature <sup>1</sup> | 17                  | white-yellow                       |

1) The temperature evaluation circuit must have the same galvanic reference potential as the encoder circuit (supply). It should therefore be connected to the supply GND. For correct evaluation, the connection potentials of the emulated temperature sensor must be in the range of the supply potentials. Valid temperature values can only be measured 50ms after the encoder supply is applied. In the currentless state, a resistance of 200kOhm is measured between pin 16 and 17 is measured. The maximum voltage between pin 16 and 17 must not exceed 16VDC. The maximum current is 15mA.

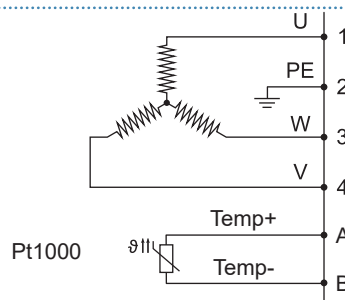
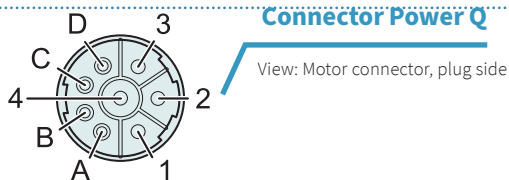

| BiSS-C-Interface: Power Connector Wiring |                   |                                 |                                    |
|--|-------------------|---------------------------------|------------------------------------|
| PS10-70x160U-BL-QJ-D34                   | Connector Power Q | Wire Color Motor Cable KPS15-04 | Wire Color Motor Cable KPS15-04/04 |
| Phase U                                  | 1                 | red                             | red                                |
| PE                                       | 2                 | yellow-green                    | yellow-green                       |
| Phase W                                  | 3                 | black                           | black                              |
| Phase V                                  | 4                 | blue                            | blue                               |
| Pt1000+ <sup>1)</sup>                    | A                 | n. c.                           | purple                             |
| Pt1000- <sup>1)</sup>                    | B                 | n. c.                           | grey                               |
| n. c.                                    | C                 | n. c.                           | yellow                             |
| n. c.                                    | D                 | n. c.                           | brown                              |

1) The temperature evaluation circuit must have the same galvanic reference potential as the encoder circuit (supply). It should therefore be connected to the supply GND. For correct evaluation, the connection potentials of the emulated temperature sensor must be in the range of the supply potentials. Valid temperature values can only be measured 50ms after the encoder supply is applied. In currentless state a resistance of 200kOhm is measured between pin A and B. The maximum voltage between pin A and B must not exceed 16VDC. The maximum current is 15mA.

**TEMPERATURE FEEDBACK DX4**

Overheating protection is provided by three internal thermistors embedded in the motor windings. These thermistors are monitored by the motor electronics. A single thermistor is simulated based on the maximum temperature readings. This is done in order to accurately monitor the temperature over the entire length of the stator and to react as quickly as possible to dynamic changes in a single motor phase. If the temperature

of the motor winding reaches its absolute maximum value, the drive amplifier/servo controller must switch off the motor to protect it from damage due to overheating. A DX4 temperature interface is available to support the temperature evaluation provided by the drive amplifier/servo controller. LinMot offers the appropriate motor cables for this purpose (see overview table in the Accessories/Motor Cables section).

**D34 (Pt1000 dual)**

Both the **signal** and **power connectors** feature an emulated **Pt1000 thermistor** for evaluating the maximum motor temperature.

**SLIDER**

**Slider Standard**

The groove marks the front slider end.

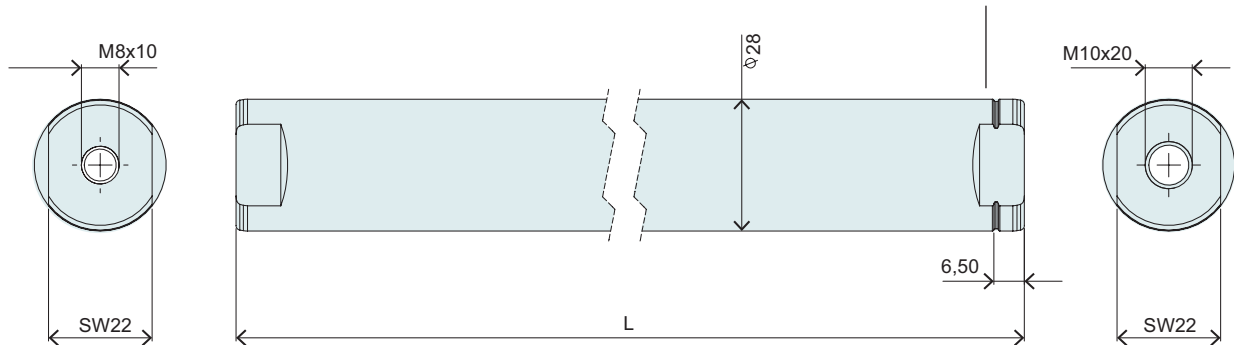

| Slider Standard   |                              |                  |                           |
|-------------------|------------------------------|------------------|---------------------------|
| Item              | Description                  | Max. Stroke [mm] | Item-No.                  |
| PL10-28x390/340   | Slider for P10-70 'standard' | 90               | <a href="#">0150-2194</a> |
| PL10-28x490/440   | Slider for P10-70 'standard' | 190              | <a href="#">0150-2195</a> |
| PL10-28x590/540   | Slider for P10-70 'standard' | 290              | <a href="#">0150-2196</a> |
| PL10-28x690/640   | Slider for P10-70 'standard' | 390              | <a href="#">0150-2197</a> |
| PL10-28x790/740   | Slider for P10-70 'standard' | 490              | <a href="#">0150-2198</a> |
| PL10-28x890/840   | Slider for P10-70 'standard' | 590              | <a href="#">0150-2199</a> |
| PL10-28x990/940   | Slider for P10-70 'standard' | 690              | <a href="#">0150-2203</a> |
| PL10-28x1190/1140 | Slider for P10-70 'standard' | 890              | <a href="#">0150-2204</a> |
| PL10-28x1390/1340 | Slider for P10-70 'standard' | 1090             | <a href="#">0150-2205</a> |
| PL10-28x1590/1540 | Slider for P10-70 'standard' | 1290             | <a href="#">0150-2206</a> |
| PL10-28x1790/1740 | Slider for P10-70 'standard' | 1490             | <a href="#">0150-2207</a> |
| PL10-28x1990/1940 | Läufer für P10-70 'standard' | 1690             | <a href="#">0150-2208</a> |

**P10-70x160U/90-BL-QJ**

**Max. Stroke:** 90 mm  
**Peak Force:** 1120 N

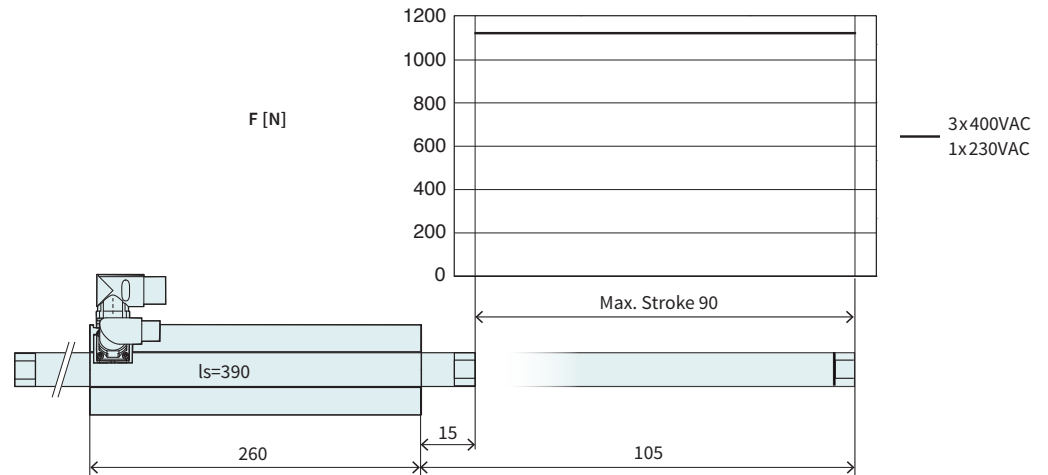

Dimensions in mm

| Stroke  |  |                                |  |
|---|--|--------------------------------|--|
| Max. Stroke   | mm (in)                                    | 90 (3.53)                      |  |
| Force   |  |                                |  |
| Max. Force <sup>1</sup> @ 1x230VAC                    | N (lbf)                                    | 1120 (252)                     |  |
| Max. Force <sup>1</sup> @ 3x400VAC                    | N (lbf)                                    | 1120 (252)                     |  |
| Max. Cont. Force [Passive cooling/ Fan / Fluid]       | N (lbf)                                    | 130 / 200 / 350 (29 / 45 / 79) |  |
| Max. Border Force relative                            | %  | 100                            |  |
| Force Constant 1                                      | N/A <sub>pk</sub> (lbf/A <sub>pk</sub> )   | 56 (12.6)                      |  |
| Force Constant 2                                      | N/A <sub>rms</sub> (lbf/A <sub>rms</sub> ) | 79.2 (17.8)                    |  |
| Velocity  |  |                                |  |
| Max. Velocity @ 1x230VAC                              | m/s (in/s)                                 | 3.2 (129.9)                    |  |
| Max. Velocity @ 3x400VAC                              | m/s (in/s)                                 | 5.6 (5.6)                      |  |
| Position Detection                                    |  |                                |  |
| Repeatability   | mm (in)                                    | ±0.05 (±0.002)                 |  |
| Linearity   | %  | ± 0.65                         |  |
| Electrical Data                                       |  |                                |  |
| Max. Current <sup>1</sup> @ 1x230VAC                  | A <sub>pk</sub> / A <sub>rms</sub>         | 19.9 / 14                      |  |
| Max. Current <sup>1</sup> @ 3x400VAC                  | A <sub>pk</sub> / A <sub>rms</sub>         | 19.9 / 14                      |  |
| Max. Cont. Current 1 [Passive cooling / Fan / Fluid]  | A <sub>pk</sub>                            | 2.3 / 3.6 / 6.3                |  |
| Max. Cont. Current 2 [Passive cooling / Fan / Fluid]  | A <sub>rms</sub>                           | 1.7 / 2.5 / 4.4                |  |
| Thermal Data  |  |                                |  |
| Max. Winding Temperature (Sensor)                     | °C   | 90                             |  |
| Thermal Resistance [Passive cooling / Fan / Fluid]    | °K/W                                       | 1.3 / 0.56 / 0.18              |  |
| Thermal Time Constant [Passive cooling / Fan / Fluid] | s  | 2100 / 500 / 110               |  |
| Mechanical Data                                       |  |                                |  |
| Slider Length   | mm (in)                                    | 390 (15)                       |  |
| Slider Mass   | g (lb)                                     | 1830 (4.03)                    |  |

1) Real time calculation of motor winding temperature is required (including monitoring).  
 If temperature monitoring is only based on temperature sensor signal (missing thermal model calculation), 60 % of the peak value has to be taken instead.

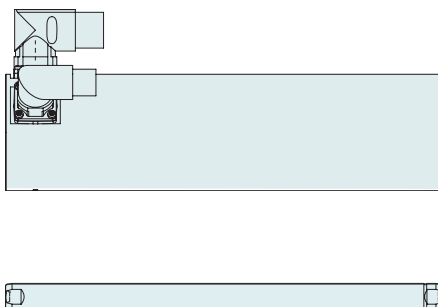

| Item                           | Description  | Item-No.                  |
|--------------------------------|--|---------------------------|
| <b>PS10-70x160U-BL-QJ</b>      | Stator 3x400VAC, LinMot Encoder                    | <a href="#">0150-1292</a> |
| <b>PS10-70x160U-BL-QJ-D04</b>  | Stator 3x400VAC, Sin/Cos Encoder 1Vpp, Pt1000 dual | <a href="#">0150-4261</a> |
| <b>PS10-70x160U-BL-QJ-D05</b>  | Stator 3x400VAC, Sin/Cos Encoder 1Vpp, PTC dual    | <a href="#">0150-4606</a> |
| <b>PS10-70x160U-BL-QJ-D08</b>  | Stator 3x400VAC, Sin/Cos Encoder 1Vpp, KTY dual    | <a href="#">0150-4511</a> |
| <b>PS10-70x160U-BL-QJ-D24</b>  | Stator 3x400VAC, A/B Encoder 1µm, Pt1000 dual      | <a href="#">0150-4131</a> |
| <b>PS10-70x160U-BL-QJ-D24S</b> | Stator 3x400VAC, A/B Encoder 5µm, Pt1000 dual      | <a href="#">0150-4596</a> |
| <b>PS10-70x160U-BL-QJ-D25</b>  | Stator 3x400VAC, A/B Encoder 1µm, PTC dual         | <a href="#">0150-5761</a> |
| <b>PS10-70x160U-BL-QJ-D25S</b> | Stator 3x400VAC, A/B Encoder 5µm, PTC dual         | <a href="#">0150-4601</a> |
| <b>PS10-70x160U-BL-QJ-D26</b>  | Stator 3x400VAC, A/B Encoder 1µm, PTC single ended | <a href="#">0150-4515</a> |
| <b>PS10-70x160U-BL-QJ-D34</b>  | Stator 3x400VAC, BiSS-C, Pt1000 dual               | <a href="#">0150-4871</a> |
| <b>PL10-28x390/340</b>         | Slider for P10-70 'standard'                       | <a href="#">0150-2194</a> |

**P10-70x160U/190-BL-QJ**

**Max. Stroke:** 190 mm  
**Peak Force:** 1120 N

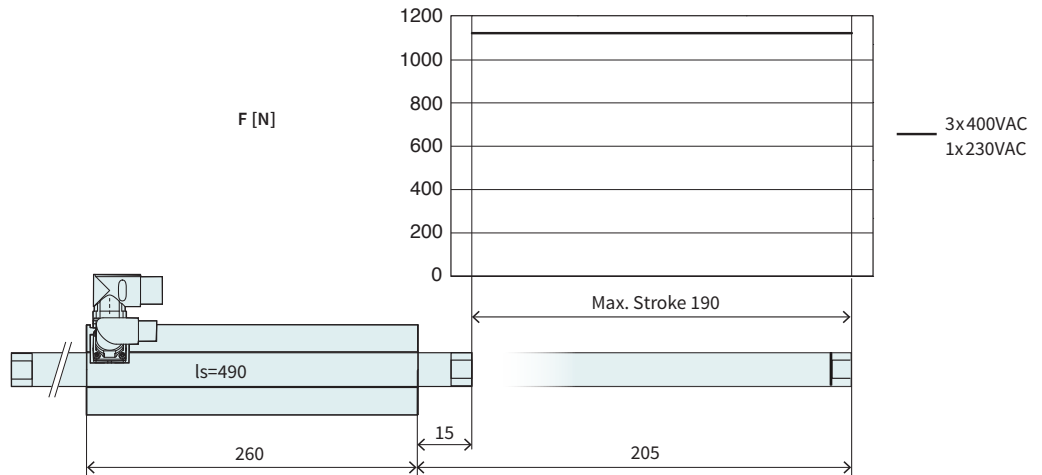

Dimensions in mm

| Stroke  |  |  |                                |
|---|--|--|--------------------------------|
| Max. Stroke   | mm (in)                                    |  | 190 (7.48)                     |
| Force   |  |  |                                |
| Max. Force <sup>1</sup> @ 1x230VAC                    | N (lbf)                                    |  | 1120 (252)                     |
| Max. Force <sup>1</sup> @ 3x400VAC                    | N (lbf)                                    |  | 1120 (252)                     |
| Max. Cont. Force [Passive cooling / Fan / Fluid]      | N (lbf)                                    |  | 130 / 200 / 350 (29 / 45 / 79) |
| Max. Border Force relative                            | %  |  | 100                            |
| Force Constant 1                                      | N/A <sub>pk</sub> (lbf/A <sub>pk</sub> )   |  | 56 (12.6)                      |
| Force Constant 2                                      | N/A <sub>rms</sub> (lbf/A <sub>rms</sub> ) |  | 79.2 (17.8)                    |
| Velocity  |  |  |                                |
| Max. Velocity @ 1x230VAC                              | m/s (in/s)                                 |  | 3.2 (129.9)                    |
| Max. Velocity @ 3x400VAC                              | m/s (in/s)                                 |  | 5.6 (5.6)                      |
| Position Detection                                    |  |  |                                |
| Repeatability   | mm (in)                                    |  | ±0.05 (±0.002)                 |
| Linearity   | %  |  | ± 0.35                         |
| Electrical Data                                       |  |  |                                |
| Max. Current <sup>1</sup> @ 1x230VAC                  | A <sub>pk</sub> / A <sub>rms</sub>         |  | 19.9 / 14                      |
| Max. Current <sup>1</sup> @ 3x400VAC                  | A <sub>pk</sub> / A <sub>rms</sub>         |  | 19.9 / 14                      |
| Max. Cont. Current 1 [Passive cooling / Fan / Fluid]  | A <sub>pk</sub>                            |  | 2.3 / 3.6 / 6.3                |
| Max. Cont. Current 2 [Passive cooling / Fan / Fluid]  | A <sub>rms</sub>                           |  | 1.7 / 2.5 / 4.4                |
| Thermal Data  |  |  |                                |
| Max. Winding Temperature (Sensor)                     | °C   |  | 90                             |
| Thermal Resistance [Passive cooling / Fan / Fluid]    | °K/W                                       |  | 1.3 / 0.56 / 0.18              |
| Thermal Time Constant [Passive cooling / Fan / Fluid] | s  |  | 2100 / 500 / 110               |
| Mechanical Data                                       |  |  |                                |
| Slider Length   | mm (in)                                    |  | 490 (19)                       |
| Slider Mass   | g (lb)                                     |  | 2300 (5.06)                    |

1) Real time calculation of motor winding temperature is required (including monitoring).  
 If temperature monitoring is only based on temperature sensor signal (missing thermal model calculation), 60 % of the peak value has to be taken instead.



| Item                           | Description  | Item-No.                  |
|--------------------------------|--|---------------------------|
| <b>PS10-70x160U-BL-QJ</b>      | Stator 3x400VAC, LinMot Encoder                    | <a href="#">0150-1292</a> |
| <b>PS10-70x160U-BL-QJ-D04</b>  | Stator 3x400VAC, Sin/Cos Encoder 1Vpp, Pt1000 dual | <a href="#">0150-4261</a> |
| <b>PS10-70x160U-BL-QJ-D05</b>  | Stator 3x400VAC, Sin/Cos Encoder 1Vpp, PTC dual    | <a href="#">0150-4606</a> |
| <b>PS10-70x160U-BL-QJ-D08</b>  | Stator 3x400VAC, Sin/Cos Encoder 1Vpp, KTY dual    | <a href="#">0150-4511</a> |
| <b>PS10-70x160U-BL-QJ-D24</b>  | Stator 3x400VAC, A/B Encoder 1µm, Pt1000 dual      | <a href="#">0150-4131</a> |
| <b>PS10-70x160U-BL-QJ-D24S</b> | Stator 3x400VAC, A/B Encoder 5µm, Pt1000 dual      | <a href="#">0150-4596</a> |
| <b>PS10-70x160U-BL-QJ-D25</b>  | Stator 3x400VAC, A/B Encoder 1µm, PTC dual         | <a href="#">0150-5761</a> |
| <b>PS10-70x160U-BL-QJ-D25S</b> | Stator 3x400VAC, A/B Encoder 5µm, PTC dual         | <a href="#">0150-4601</a> |
| <b>PS10-70x160U-BL-QJ-D26</b>  | Stator 3x400VAC, A/B Encoder 1µm, PTC single ended | <a href="#">0150-4515</a> |
| <b>PS10-70x160U-BL-QJ-D34</b>  | Stator 3x400VAC, BiSS-C, Pt1000 dual               | <a href="#">0150-4871</a> |
| <b>PL10-28x490/440</b>         | Slider for P10-70 'standard'                       | <a href="#">0150-2195</a> |

**P10-70x160U/290-BL-QJ**

**Max. Stroke:** 290 mm  
**Peak Force:** 1120 N

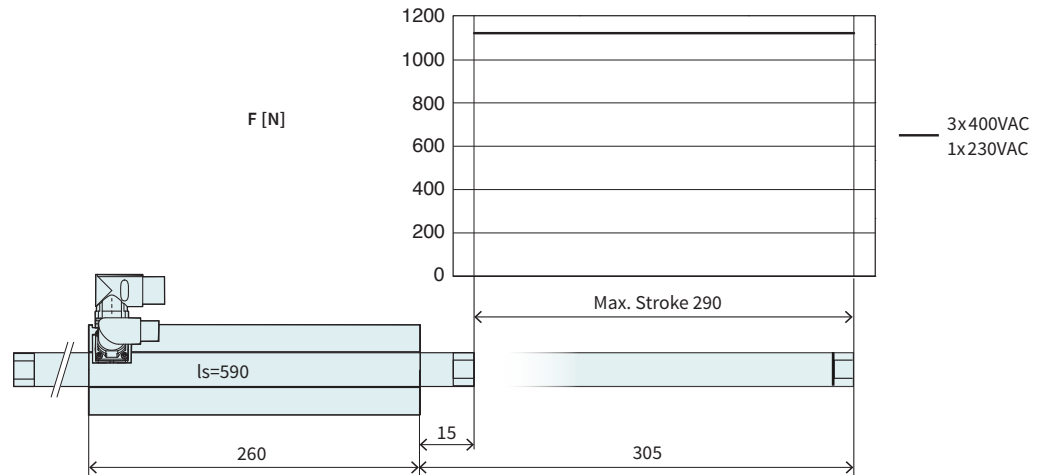

Dimensions in mm

| Stroke  |  |  |                                |
|---|--|--|--------------------------------|
| Max. Stroke   | mm (in)                                    |  | 290 (11.4)                     |
| Force   |  |  |                                |
| Max. Force <sup>1</sup> @ 1x230VAC                    | N (lbf)                                    |  | 1120 (252)                     |
| Max. Force <sup>1</sup> @ 3x400VAC                    | N (lbf)                                    |  | 1120 (252)                     |
| Max. Cont. Force [Passive cooling/ Fan / Fluid]       | N (lbf)                                    |  | 130 / 200 / 350 (29 / 45 / 79) |
| Max. Border Force relative                            | %  |  | 100                            |
| Force Constant 1                                      | N/A <sub>pk</sub> (lbf/A <sub>pk</sub> )   |  | 56 (12.6)                      |
| Force Constant 2                                      | N/A <sub>rms</sub> (lbf/A <sub>rms</sub> ) |  | 79.2 (17.8)                    |
| Velocity  |  |  |                                |
| Max. Velocity @ 1x230VAC                              | m/s (in/s)                                 |  | 3.2 (129.9)                    |
| Max. Velocity @ 3x400VAC                              | m/s (in/s)                                 |  | 5.6 (5.6)                      |
| Position Detection                                    |  |  |                                |
| Repeatability   | mm (in)                                    |  | ±0.05 (±0.002)                 |
| Linearity   | %  |  | ± 0.25                         |
| Electrical Data                                       |  |  |                                |
| Max. Current <sup>1</sup> @ 1x230VAC                  | A <sub>pk</sub> / A <sub>rms</sub>         |  | 19.9 / 14                      |
| Max. Current <sup>1</sup> @ 3x400VAC                  | A <sub>pk</sub> / A <sub>rms</sub>         |  | 19.9 / 14                      |
| Max. Cont. Current 1 [Passive cooling / Fan / Fluid]  | A <sub>pk</sub>                            |  | 2.3 / 3.6 / 6.3                |
| Max. Cont. Current 2 [Passive cooling / Fan / Fluid]  | A <sub>rms</sub>                           |  | 1.7 / 2.5 / 4.4                |
| Thermal Data  |  |  |                                |
| Max. Winding Temperature (Sensor)                     | °C   |  | 90                             |
| Thermal Resistance [Passive cooling / Fan / Fluid]    | °K/W                                       |  | 1.3 / 0.56 / 0.18              |
| Thermal Time Constant [Passive cooling / Fan / Fluid] | s  |  | 2100 / 500 / 110               |
| Mechanical Data                                       |  |  |                                |
| Slider Length   | mm (in)                                    |  | 590 (23)                       |
| Slider Mass   | g (lb)                                     |  | 2770 (6.09)                    |

1) Real time calculation of motor winding temperature is required (including monitoring).  
 If temperature monitoring is only based on temperature sensor signal (missing thermal model calculation), 60 % of the peak value has to be taken instead.

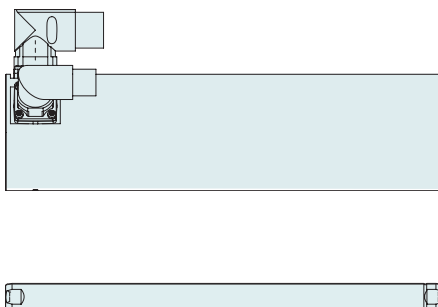

| Item                           | Description  | Item-No.                  |
|--------------------------------|--|---------------------------|
| <b>PS10-70x160U-BL-QJ</b>      | Stator 3x400VAC, LinMot Encoder                    | <a href="#">0150-1292</a> |
| <b>PS10-70x160U-BL-QJ-D04</b>  | Stator 3x400VAC, Sin/Cos Encoder 1Vpp, Pt1000 dual | <a href="#">0150-4261</a> |
| <b>PS10-70x160U-BL-QJ-D05</b>  | Stator 3x400VAC, Sin/Cos Encoder 1Vpp, PTC dual    | <a href="#">0150-4606</a> |
| <b>PS10-70x160U-BL-QJ-D08</b>  | Stator 3x400VAC, Sin/Cos Encoder 1Vpp, KTY dual    | <a href="#">0150-4511</a> |
| <b>PS10-70x160U-BL-QJ-D24</b>  | Stator 3x400VAC, A/B Encoder 1µm, Pt1000 dual      | <a href="#">0150-4131</a> |
| <b>PS10-70x160U-BL-QJ-D24S</b> | Stator 3x400VAC, A/B Encoder 5µm, Pt1000 dual      | <a href="#">0150-4596</a> |
| <b>PS10-70x160U-BL-QJ-D25</b>  | Stator 3x400VAC, A/B Encoder 1µm, PTC dual         | <a href="#">0150-5761</a> |
| <b>PS10-70x160U-BL-QJ-D25S</b> | Stator 3x400VAC, A/B Encoder 5µm, PTC dual         | <a href="#">0150-4601</a> |
| <b>PS10-70x160U-BL-QJ-D26</b>  | Stator 3x400VAC, A/B Encoder 1µm, PTC single ended | <a href="#">0150-4515</a> |
| <b>PS10-70x160U-BL-QJ-D34</b>  | Stator 3x400VAC, BiSS-C, Pt1000 dual               | <a href="#">0150-4871</a> |
| <b>PL10-28x590/540</b>         | Slider for P10-70 'standard'                       | <a href="#">0150-2196</a> |

**P10-70x160U/390-BL-QJ**

**Max. Stroke:** 390 mm  
**Peak Force:** 1120 N

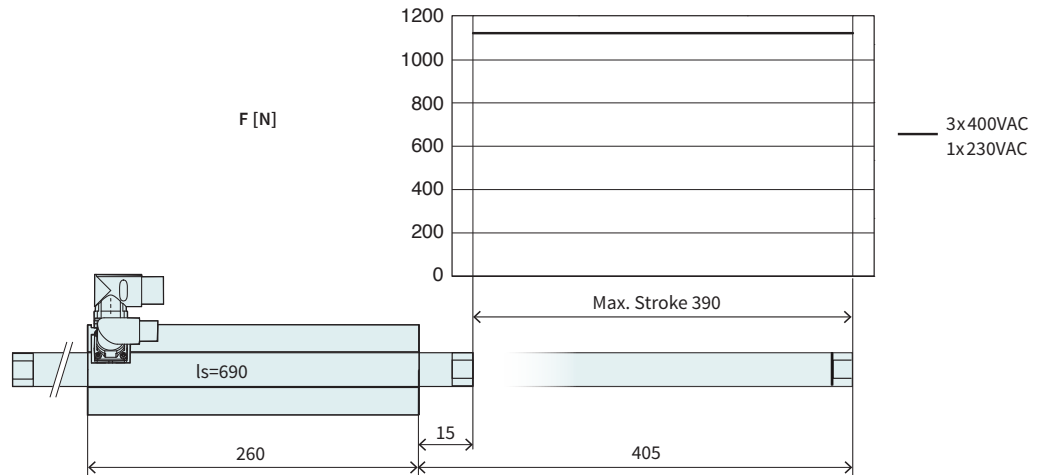

Dimensions in mm

| Stroke  |  |  |                                |
|---|--|--|--------------------------------|
| Max. Stroke   | mm (in)                                    |  | 390 (15.4)                     |
| Force   |  |  |                                |
| Max. Force <sup>1</sup> @ 1x230VAC                    | N (lbf)                                    |  | 1120 (252)                     |
| Max. Force <sup>1</sup> @ 3x400VAC                    | N (lbf)                                    |  | 1120 (252)                     |
| Max. Cont. Force [Passive cooling / Fan / Fluid]      | N (lbf)                                    |  | 130 / 200 / 350 (29 / 45 / 79) |
| Max. Border Force relative                            | %  |  | 100                            |
| Force Constant 1                                      | N/A <sub>pk</sub> (lbf/A <sub>pk</sub> )   |  | 56 (12.6)                      |
| Force Constant 2                                      | N/A <sub>rms</sub> (lbf/A <sub>rms</sub> ) |  | 79.2 (17.8)                    |
| Velocity  |  |  |                                |
| Max. Velocity @ 1x230VAC                              | m/s (in/s)                                 |  | 3.2 (129.9)                    |
| Max. Velocity @ 3x400VAC                              | m/s (in/s)                                 |  | 5.6 (5.6)                      |
| Position Detection                                    |  |  |                                |
| Repeatability   | mm (in)                                    |  | ±0.05 (±0.002)                 |
| Linearity   | %  |  | ± 0.25                         |
| Electrical Data                                       |  |  |                                |
| Max. Current <sup>1</sup> @ 1x230VAC                  | A <sub>pk</sub> / A <sub>rms</sub>         |  | 19.9 / 14                      |
| Max. Current <sup>1</sup> @ 3x400VAC                  | A <sub>pk</sub> / A <sub>rms</sub>         |  | 19.9 / 14                      |
| Max. Cont. Current 1 [Passive cooling / Fan / Fluid]  | A <sub>pk</sub>                            |  | 2.3 / 3.6 / 6.3                |
| Max. Cont. Current 2 [Passive cooling / Fan / Fluid]  | A <sub>rms</sub>                           |  | 1.7 / 2.5 / 4.4                |
| Thermal Data  |  |  |                                |
| Max. Winding Temperature (Sensor)                     | °C   |  | 90                             |
| Thermal Resistance [Passive cooling / Fan / Fluid]    | °K/W                                       |  | 1.3 / 0.56 / 0.18              |
| Thermal Time Constant [Passive cooling / Fan / Fluid] | s  |  | 2100 / 500 / 110               |
| Mechanical Data                                       |  |  |                                |
| Slider Length   | mm (in)                                    |  | 690 (27)                       |
| Slider Mass   | g (lb)                                     |  | 3240 (7.13)                    |

<sup>1</sup> Real time calculation of motor winding temperature is required (including monitoring).  
 If temperature monitoring is only based on temperature sensor signal (missing thermal model calculation), 60 % of the peak value has to be taken instead.



| Item                           | Description  | Item-No.                  |
|--------------------------------|--|---------------------------|
| <b>PS10-70x160U-BL-QJ</b>      | Stator 3x400VAC, LinMot Encoder                    | <a href="#">0150-1292</a> |
| <b>PS10-70x160U-BL-QJ-D04</b>  | Stator 3x400VAC, Sin/Cos Encoder 1Vpp, Pt1000 dual | <a href="#">0150-4261</a> |
| <b>PS10-70x160U-BL-QJ-D05</b>  | Stator 3x400VAC, Sin/Cos Encoder 1Vpp, PTC dual    | <a href="#">0150-4606</a> |
| <b>PS10-70x160U-BL-QJ-D08</b>  | Stator 3x400VAC, Sin/Cos Encoder 1Vpp, KTY dual    | <a href="#">0150-4511</a> |
| <b>PS10-70x160U-BL-QJ-D24</b>  | Stator 3x400VAC, A/B Encoder 1µm, Pt1000 dual      | <a href="#">0150-4131</a> |
| <b>PS10-70x160U-BL-QJ-D24S</b> | Stator 3x400VAC, A/B Encoder 5µm, Pt1000 dual      | <a href="#">0150-4596</a> |
| <b>PS10-70x160U-BL-QJ-D25</b>  | Stator 3x400VAC, A/B Encoder 1µm, PTC dual         | <a href="#">0150-5761</a> |
| <b>PS10-70x160U-BL-QJ-D25S</b> | Stator 3x400VAC, A/B Encoder 5µm, PTC dual         | <a href="#">0150-4601</a> |
| <b>PS10-70x160U-BL-QJ-D26</b>  | Stator 3x400VAC, A/B Encoder 1µm, PTC single ended | <a href="#">0150-4515</a> |
| <b>PS10-70x160U-BL-QJ-D34</b>  | Stator 3x400VAC, BiSS-C, Pt1000 dual               | <a href="#">0150-4871</a> |
| <b>PL10-28x690/640</b>         | Slider for P10-70 'standard'                       | <a href="#">0150-2197</a> |

**P10-70x160U/490-BL-QJ**

**Max. Stroke:** 490 mm  
**Peak Force:** 1120 N

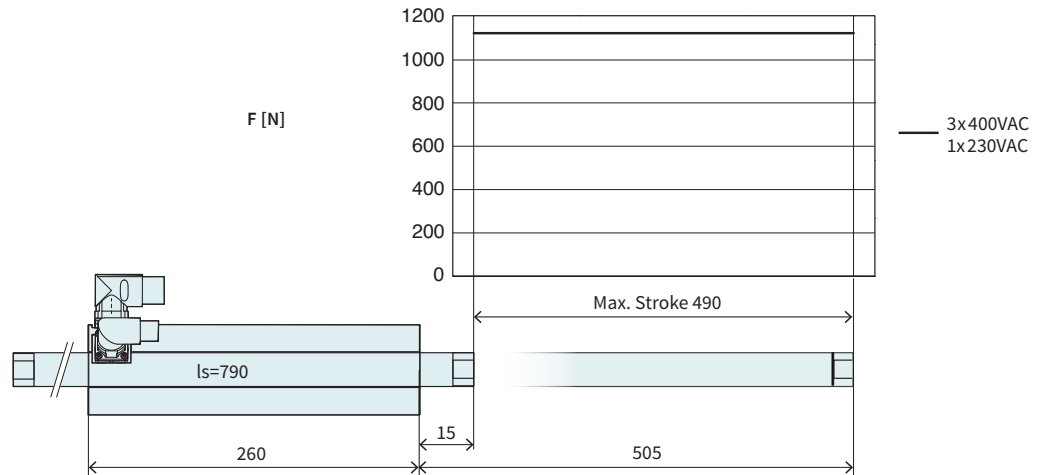

Dimensions in mm

| Stroke  |  |  |                                |
|---|--|--|--------------------------------|
| Max. Stroke   | mm (in)                                    |  | 490 (19.3)                     |
| Force   |  |  |                                |
| Max. Force <sup>1</sup> @ 1x230VAC                    | N (lbf)                                    |  | 1120 (252)                     |
| Max. Force <sup>1</sup> @ 3x400VAC                    | N (lbf)                                    |  | 1120 (252)                     |
| Max. Cont. Force [Passive cooling/ Fan / Fluid]       | N (lbf)                                    |  | 130 / 200 / 350 (29 / 45 / 79) |
| Max. Border Force relative                            | %  |  | 100                            |
| Force Constant 1                                      | N/A <sub>pk</sub> (lbf/A <sub>pk</sub> )   |  | 56 (12.6)                      |
| Force Constant 2                                      | N/A <sub>rms</sub> (lbf/A <sub>rms</sub> ) |  | 79.2 (17.8)                    |
| Velocity  |  |  |                                |
| Max. Velocity @ 1x230VAC                              | m/s (in/s)                                 |  | 3.2 (129.9)                    |
| Max. Velocity @ 3x400VAC                              | m/s (in/s)                                 |  | 5.6 (5.6)                      |
| Position Detection                                    |  |  |                                |
| Repeatability   | mm (in)                                    |  | ±0.05 (±0.002)                 |
| Linearity   | %  |  | ± 0.2                          |
| Electrical Data                                       |  |  |                                |
| Max. Current <sup>1</sup> @ 1x230VAC                  | A <sub>pk</sub> / A <sub>rms</sub>         |  | 19.9 / 14                      |
| Max. Current <sup>1</sup> @ 3x400VAC                  | A <sub>pk</sub> / A <sub>rms</sub>         |  | 19.9 / 14                      |
| Max. Cont. Current 1 [Passive cooling / Fan / Fluid]  | A <sub>pk</sub>                            |  | 2.3 / 3.6 / 6.3                |
| Max. Cont. Current 2 [Passive cooling / Fan / Fluid]  | A <sub>rms</sub>                           |  | 1.7 / 2.5 / 4.4                |
| Thermal Data  |  |  |                                |
| Max. Winding Temperature (Sensor)                     | °C   |  | 90                             |
| Thermal Resistance [Passive cooling / Fan / Fluid]    | °K/W                                       |  | 1.3 / 0.56 / 0.18              |
| Thermal Time Constant [Passive cooling / Fan / Fluid] | s  |  | 2100 / 500 / 110               |
| Mechanical Data                                       |  |  |                                |
| Slider Length   | mm (in)                                    |  | 790 (31)                       |
| Slider Mass   | g (lb)                                     |  | 3710 (8.16)                    |

1) Real time calculation of motor winding temperature is required (including monitoring).  
 If temperature monitoring is only based on temperature sensor signal (missing thermal model calculation), 60 % of the peak value has to be taken instead.

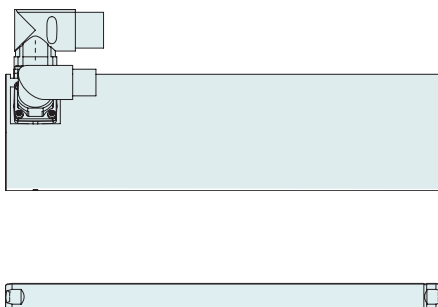

| Item                           | Description  | Item-No.                  |
|--------------------------------|--|---------------------------|
| <b>PS10-70x160U-BL-QJ</b>      | Stator 3x400VAC, LinMot Encoder                    | <a href="#">0150-1292</a> |
| <b>PS10-70x160U-BL-QJ-D04</b>  | Stator 3x400VAC, Sin/Cos Encoder 1Vpp, Pt1000 dual | <a href="#">0150-4261</a> |
| <b>PS10-70x160U-BL-QJ-D05</b>  | Stator 3x400VAC, Sin/Cos Encoder 1Vpp, PTC dual    | <a href="#">0150-4606</a> |
| <b>PS10-70x160U-BL-QJ-D08</b>  | Stator 3x400VAC, Sin/Cos Encoder 1Vpp, KTY dual    | <a href="#">0150-4511</a> |
| <b>PS10-70x160U-BL-QJ-D24</b>  | Stator 3x400VAC, A/B Encoder 1µm, Pt1000 dual      | <a href="#">0150-4131</a> |
| <b>PS10-70x160U-BL-QJ-D24S</b> | Stator 3x400VAC, A/B Encoder 5µm, Pt1000 dual      | <a href="#">0150-4596</a> |
| <b>PS10-70x160U-BL-QJ-D25</b>  | Stator 3x400VAC, A/B Encoder 1µm, PTC dual         | <a href="#">0150-5761</a> |
| <b>PS10-70x160U-BL-QJ-D25S</b> | Stator 3x400VAC, A/B Encoder 5µm, PTC dual         | <a href="#">0150-4601</a> |
| <b>PS10-70x160U-BL-QJ-D26</b>  | Stator 3x400VAC, A/B Encoder 1µm, PTC single ended | <a href="#">0150-4515</a> |
| <b>PS10-70x160U-BL-QJ-D34</b>  | Stator 3x400VAC, BiSS-C, Pt1000 dual               | <a href="#">0150-4871</a> |
| <b>PL10-28x790/740</b>         | Slider for P10-70 'standard'                       | <a href="#">0150-2198</a> |

**P10-70x160U/590-BL-QJ**

**Max. Stroke:** 590 mm  
**Peak Force:** 1120 N

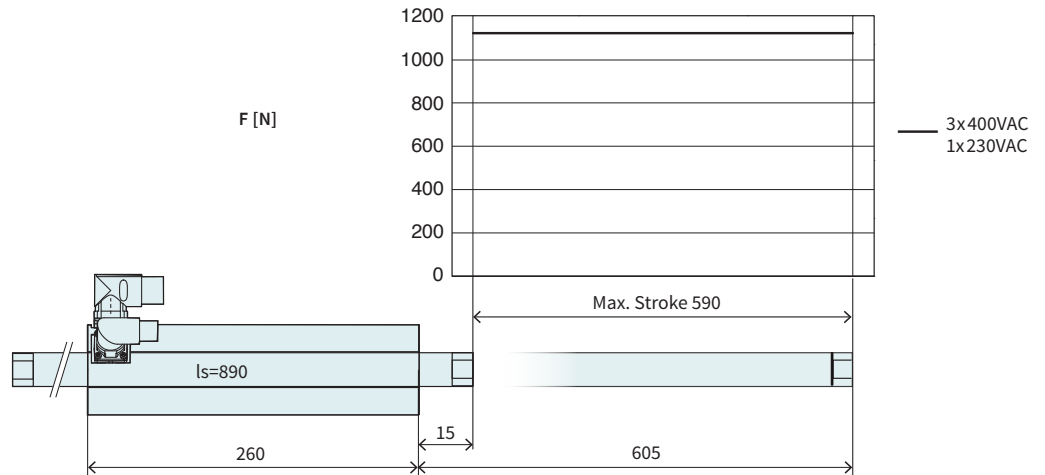

Dimensions in mm

| Stroke  |  |                                |  |
|---|--|--------------------------------|--|
| Max. Stroke   | mm (in)                                    | 590 (23.19)                    |  |
| Force   |  |                                |  |
| Max. Force <sup>1</sup> @ 1x230VAC                    | N (lbf)                                    | 1120 (252)                     |  |
| Max. Force <sup>1</sup> @ 3x400VAC                    | N (lbf)                                    | 1120 (252)                     |  |
| Max. Cont. Force [Passive cooling / Fan / Fluid]      | N (lbf)                                    | 130 / 200 / 350 (29 / 45 / 79) |  |
| Max. Border Force relative                            | %  | 100                            |  |
| Force Constant 1                                      | N/A <sub>pk</sub> (lbf/A <sub>pk</sub> )   | 56 (12.6)                      |  |
| Force Constant 2                                      | N/A <sub>rms</sub> (lbf/A <sub>rms</sub> ) | 79.2 (17.8)                    |  |
| Velocity  |  |                                |  |
| Max. Velocity @ 1x230VAC                              | m/s (in/s)                                 | 3.2 (129.9)                    |  |
| Max. Velocity @ 3x400VAC                              | m/s (in/s)                                 | 5.6 (5.6)                      |  |
| Position Detection                                    |  |                                |  |
| Repeatability   | mm (in)                                    | ±0.05 (±0.002)                 |  |
| Linearity   | %  | ± 0.2                          |  |
| Electrical Data                                       |  |                                |  |
| Max. Current <sup>1</sup> @ 1x230VAC                  | A <sub>pk</sub> / A <sub>rms</sub>         | 19.9 / 14                      |  |
| Max. Current <sup>1</sup> @ 3x400VAC                  | A <sub>pk</sub> / A <sub>rms</sub>         | 19.9 / 14                      |  |
| Max. Cont. Current 1 [Passive cooling / Fan / Fluid]  | A <sub>pk</sub>                            | 2.3 / 3.6 / 6.3                |  |
| Max. Cont. Current 2 [Passive cooling / Fan / Fluid]  | A <sub>rms</sub>                           | 1.7 / 2.5 / 4.4                |  |
| Thermal Data  |  |                                |  |
| Max. Winding Temperature (Sensor)                     | °C   | 90                             |  |
| Thermal Resistance [Passive cooling / Fan / Fluid]    | °K/W                                       | 1.3 / 0.56 / 0.18              |  |
| Thermal Time Constant [Passive cooling / Fan / Fluid] | s  | 2100 / 500 / 110               |  |
| Mechanical Data                                       |  |                                |  |
| Slider Length   | mm (in)                                    | 890 (35)                       |  |
| Slider Mass   | g (lb)                                     | 4180 (9.2)                     |  |

1) Real time calculation of motor winding temperature is required (including monitoring).  
 If temperature monitoring is only based on temperature sensor signal (missing thermal model calculation), 60 % of the peak value has to be taken instead.



| Item                           | Description  | Item-No.                  |
|--------------------------------|--|---------------------------|
| <b>PS10-70x160U-BL-QJ</b>      | Stator 3x400VAC, LinMot Encoder                    | <a href="#">0150-1292</a> |
| <b>PS10-70x160U-BL-QJ-D04</b>  | Stator 3x400VAC, Sin/Cos Encoder 1Vpp, Pt1000 dual | <a href="#">0150-4261</a> |
| <b>PS10-70x160U-BL-QJ-D05</b>  | Stator 3x400VAC, Sin/Cos Encoder 1Vpp, PTC dual    | <a href="#">0150-4606</a> |
| <b>PS10-70x160U-BL-QJ-D08</b>  | Stator 3x400VAC, Sin/Cos Encoder 1Vpp, KTY dual    | <a href="#">0150-4511</a> |
| <b>PS10-70x160U-BL-QJ-D24</b>  | Stator 3x400VAC, A/B Encoder 1µm, Pt1000 dual      | <a href="#">0150-4131</a> |
| <b>PS10-70x160U-BL-QJ-D24S</b> | Stator 3x400VAC, A/B Encoder 5µm, Pt1000 dual      | <a href="#">0150-4596</a> |
| <b>PS10-70x160U-BL-QJ-D25</b>  | Stator 3x400VAC, A/B Encoder 1µm, PTC dual         | <a href="#">0150-5761</a> |
| <b>PS10-70x160U-BL-QJ-D25S</b> | Stator 3x400VAC, A/B Encoder 5µm, PTC dual         | <a href="#">0150-4601</a> |
| <b>PS10-70x160U-BL-QJ-D26</b>  | Stator 3x400VAC, A/B Encoder 1µm, PTC single ended | <a href="#">0150-4515</a> |
| <b>PS10-70x160U-BL-QJ-D34</b>  | Stator 3x400VAC, BiSS-C, Pt1000 dual               | <a href="#">0150-4871</a> |
| <b>PL10-28x890/840</b>         | Slider for P10-70 'standard'                       | <a href="#">0150-2199</a> |

**P10-70x160U/690-BL-QJ**

**Max. Stroke:** 690 mm  
**Peak Force:** 1120 N

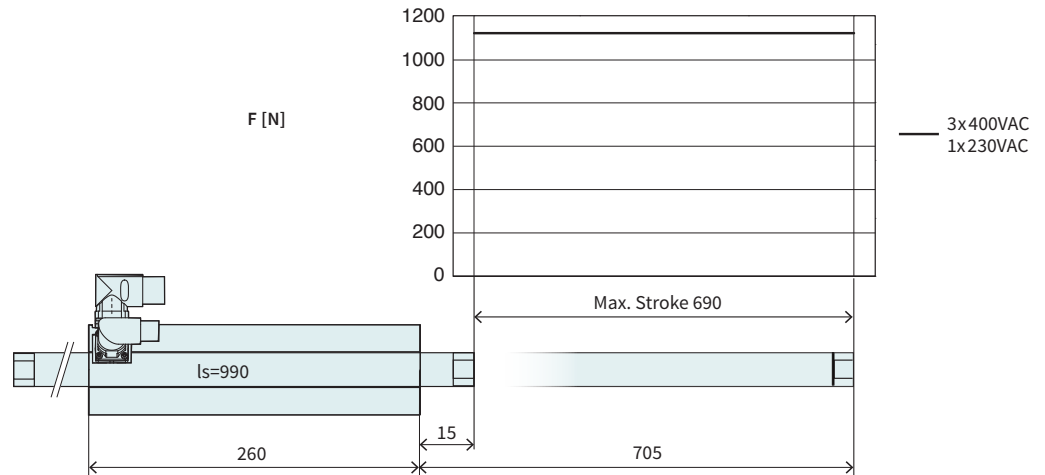

Dimensions in mm

| Stroke  |  |                                |  |
|---|--|--------------------------------|--|
| Max. Stroke   | mm (in)                                    | 690 (27.19)                    |  |
| Force   |  |                                |  |
| Max. Force <sup>1</sup> @ 1x230VAC                    | N (lbf)                                    | 1120 (252)                     |  |
| Max. Force <sup>1</sup> @ 3x400VAC                    | N (lbf)                                    | 1120 (252)                     |  |
| Max. Cont. Force [Passive cooling/ Fan / Fluid]       | N (lbf)                                    | 130 / 200 / 350 (29 / 45 / 79) |  |
| Max. Border Force relative                            | %  | 100                            |  |
| Force Constant 1                                      | N/A <sub>pk</sub> (lbf/A <sub>pk</sub> )   | 56 (12.6)                      |  |
| Force Constant 2                                      | N/A <sub>rms</sub> (lbf/A <sub>rms</sub> ) | 79.2 (17.8)                    |  |
| Velocity  |  |                                |  |
| Max. Velocity @ 1x230VAC                              | m/s (in/s)                                 | 3.2 (129.9)                    |  |
| Max. Velocity @ 3x400VAC                              | m/s (in/s)                                 | 5.6 (5.6)                      |  |
| Position Detection                                    |  |                                |  |
| Repeatability   | mm (in)                                    | ±0.05 (±0.002)                 |  |
| Linearity   | %  | ± 0.15                         |  |
| Electrical Data                                       |  |                                |  |
| Max. Current <sup>1</sup> @ 1x230VAC                  | A <sub>pk</sub> / A <sub>rms</sub>         | 19.9 / 14                      |  |
| Max. Current <sup>1</sup> @ 3x400VAC                  | A <sub>pk</sub> / A <sub>rms</sub>         | 19.9 / 14                      |  |
| Max. Cont. Current 1 [Passive cooling / Fan / Fluid]  | A <sub>pk</sub>                            | 2.3 / 3.6 / 6.3                |  |
| Max. Cont. Current 2 [Passive cooling / Fan / Fluid]  | A <sub>rms</sub>                           | 1.7 / 2.5 / 4.4                |  |
| Thermal Data  |  |                                |  |
| Max. Winding Temperature (Sensor)                     | °C   | 90                             |  |
| Thermal Resistance [Passive cooling / Fan / Fluid]    | °K/W                                       | 1.3 / 0.56 / 0.18              |  |
| Thermal Time Constant [Passive cooling / Fan / Fluid] | s  | 2100 / 500 / 110               |  |
| Mechanical Data                                       |  |                                |  |
| Slider Length   | mm (in)                                    | 990 (39)                       |  |
| Slider Mass   | g (lb)                                     | 4650 (10.23)                   |  |

1) Real time calculation of motor winding temperature is required (including monitoring).  
 If temperature monitoring is only based on temperature sensor signal (missing thermal model calculation), 60 % of the peak value has to be taken instead.

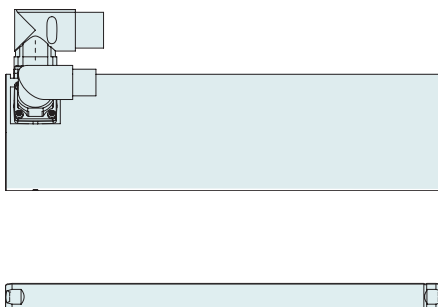

| Item                           | Description  | Item-No.                  |
|--------------------------------|--|---------------------------|
| <b>PS10-70x160U-BL-QJ</b>      | Stator 3x400VAC, LinMot Encoder                    | <a href="#">0150-1292</a> |
| <b>PS10-70x160U-BL-QJ-D04</b>  | Stator 3x400VAC, Sin/Cos Encoder 1Vpp, Pt1000 dual | <a href="#">0150-4261</a> |
| <b>PS10-70x160U-BL-QJ-D05</b>  | Stator 3x400VAC, Sin/Cos Encoder 1Vpp, PTC dual    | <a href="#">0150-4606</a> |
| <b>PS10-70x160U-BL-QJ-D08</b>  | Stator 3x400VAC, Sin/Cos Encoder 1Vpp, KTY dual    | <a href="#">0150-4511</a> |
| <b>PS10-70x160U-BL-QJ-D24</b>  | Stator 3x400VAC, A/B Encoder 1µm, Pt1000 dual      | <a href="#">0150-4131</a> |
| <b>PS10-70x160U-BL-QJ-D24S</b> | Stator 3x400VAC, A/B Encoder 5µm, Pt1000 dual      | <a href="#">0150-4596</a> |
| <b>PS10-70x160U-BL-QJ-D25</b>  | Stator 3x400VAC, A/B Encoder 1µm, PTC dual         | <a href="#">0150-5761</a> |
| <b>PS10-70x160U-BL-QJ-D25S</b> | Stator 3x400VAC, A/B Encoder 5µm, PTC dual         | <a href="#">0150-4601</a> |
| <b>PS10-70x160U-BL-QJ-D26</b>  | Stator 3x400VAC, A/B Encoder 1µm, PTC single ended | <a href="#">0150-4515</a> |
| <b>PS10-70x160U-BL-QJ-D34</b>  | Stator 3x400VAC, BiSS-C, Pt1000 dual               | <a href="#">0150-4871</a> |
| <b>PL10-28x990/940</b>         | Slider for P10-70 'standard'                       | <a href="#">0150-2203</a> |

**P10-70x160U/890-BL-QJ**

**Max. Stroke:** 890 mm  
**Peak Force:** 1120 N

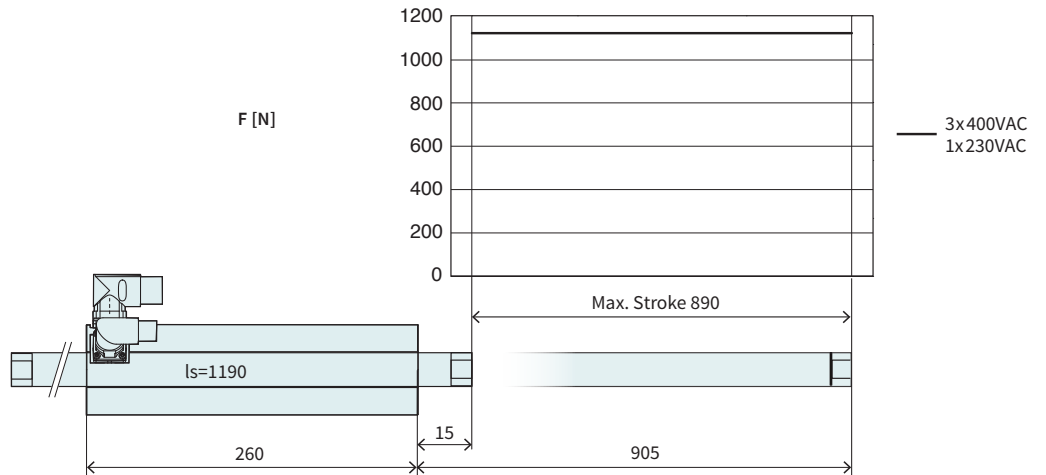

Dimensions in mm

| Stroke  |  |  |                                |
|---|--|--|--------------------------------|
| Max. Stroke   | mm (in)                                    |  | 890 (34.99)                    |
| Force   |  |  |                                |
| Max. Force <sup>1</sup> @ 1x230VAC                    | N (lbf)                                    |  | 1120 (252)                     |
| Max. Force <sup>1</sup> @ 3x400VAC                    | N (lbf)                                    |  | 1120 (252)                     |
| Max. Cont. Force [Passive cooling / Fan / Fluid]      | N (lbf)                                    |  | 130 / 200 / 350 (29 / 45 / 79) |
| Max. Border Force relative                            | %  |  | 100                            |
| Force Constant 1                                      | N/A <sub>pk</sub> (lbf/A <sub>pk</sub> )   |  | 56 (12.6)                      |
| Force Constant 2                                      | N/A <sub>rms</sub> (lbf/A <sub>rms</sub> ) |  | 79.2 (17.8)                    |
| Velocity  |  |  |                                |
| Max. Velocity @ 1x230VAC                              | m/s (in/s)                                 |  | 3.2 (129.9)                    |
| Max. Velocity @ 3x400VAC                              | m/s (in/s)                                 |  | 5.6 (5.6)                      |
| Position Detection                                    |  |  |                                |
| Repeatability   | mm (in)                                    |  | ±0.05 (±0.002)                 |
| Linearity   | %  |  | ± 0.15                         |
| Electrical Data                                       |  |  |                                |
| Max. Current <sup>1</sup> @ 1x230VAC                  | A <sub>pk</sub> / A <sub>rms</sub>         |  | 19.9 / 14                      |
| Max. Current <sup>1</sup> @ 3x400VAC                  | A <sub>pk</sub> / A <sub>rms</sub>         |  | 19.9 / 14                      |
| Max. Cont. Current 1 [Passive cooling / Fan / Fluid]  | A <sub>pk</sub>                            |  | 2.3 / 3.6 / 6.3                |
| Max. Cont. Current 2 [Passive cooling / Fan / Fluid]  | A <sub>rms</sub>                           |  | 1.7 / 2.5 / 4.4                |
| Thermal Data  |  |  |                                |
| Max. Winding Temperature (Sensor)                     | °C   |  | 90                             |
| Thermal Resistance [Passive cooling / Fan / Fluid]    | °K/W                                       |  | 1.3 / 0.56 / 0.18              |
| Thermal Time Constant [Passive cooling / Fan / Fluid] | s  |  | 2100 / 500 / 110               |
| Mechanical Data                                       |  |  |                                |
| Slider Length   | mm (in)                                    |  | 1190 (47)                      |
| Slider Mass   | g (lb)                                     |  | 5590 (12.3)                    |

<sup>1</sup> Real time calculation of motor winding temperature is required (including monitoring).  
 If temperature monitoring is only based on temperature sensor signal (missing thermal model calculation), 60 % of the peak value has to be taken instead.



| Item                           | Description  | Item-No.                  |
|--------------------------------|--|---------------------------|
| <b>PS10-70x160U-BL-QJ</b>      | Stator 3x400VAC, LinMot Encoder                    | <a href="#">0150-1292</a> |
| <b>PS10-70x160U-BL-QJ-D04</b>  | Stator 3x400VAC, Sin/Cos Encoder 1Vpp, Pt1000 dual | <a href="#">0150-4261</a> |
| <b>PS10-70x160U-BL-QJ-D05</b>  | Stator 3x400VAC, Sin/Cos Encoder 1Vpp, PTC dual    | <a href="#">0150-4606</a> |
| <b>PS10-70x160U-BL-QJ-D08</b>  | Stator 3x400VAC, Sin/Cos Encoder 1Vpp, KTY dual    | <a href="#">0150-4511</a> |
| <b>PS10-70x160U-BL-QJ-D24</b>  | Stator 3x400VAC, A/B Encoder 1µm, Pt1000 dual      | <a href="#">0150-4131</a> |
| <b>PS10-70x160U-BL-QJ-D24S</b> | Stator 3x400VAC, A/B Encoder 5µm, Pt1000 dual      | <a href="#">0150-4596</a> |
| <b>PS10-70x160U-BL-QJ-D25</b>  | Stator 3x400VAC, A/B Encoder 1µm, PTC dual         | <a href="#">0150-5761</a> |
| <b>PS10-70x160U-BL-QJ-D25S</b> | Stator 3x400VAC, A/B Encoder 5µm, PTC dual         | <a href="#">0150-4601</a> |
| <b>PS10-70x160U-BL-QJ-D26</b>  | Stator 3x400VAC, A/B Encoder 1µm, PTC single ended | <a href="#">0150-4515</a> |
| <b>PS10-70x160U-BL-QJ-D34</b>  | Stator 3x400VAC, BiSS-C, Pt1000 dual               | <a href="#">0150-4871</a> |
| <b>PL10-28x1190/1140</b>       | Slider for P10-70 'standard'                       | <a href="#">0150-2204</a> |

**P10-70x160U/1090-BL-QJ**

**Max. Stroke:** 1090 mm  
**Peak Force:** 1120 N

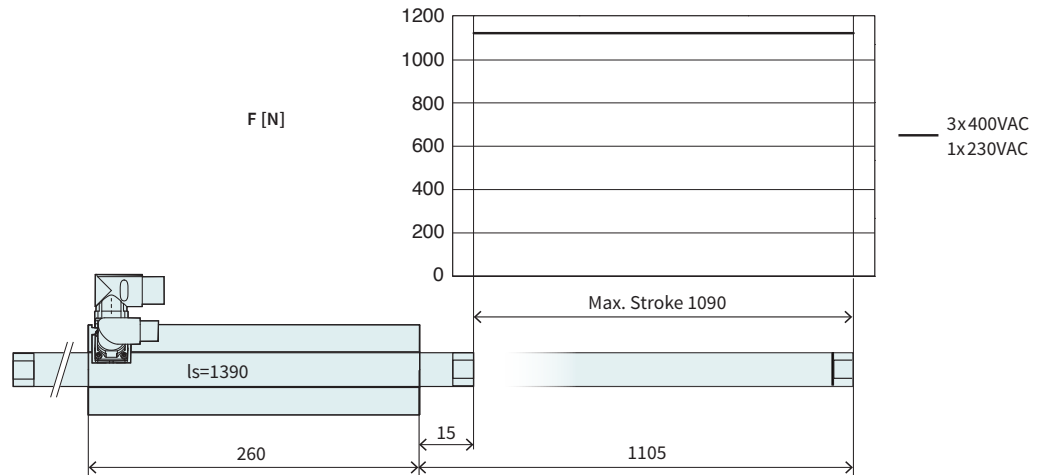

Dimensions in mm

| Stroke  |  |  |                                |
|---|--|--|--------------------------------|
| Max. Stroke   | mm (in)                                    |  | 1090 (42.89)                   |
| Force   |  |  |                                |
| Max. Force <sup>1</sup> @ 1x230VAC                    | N (lbf)                                    |  | 1120 (252)                     |
| Max. Force <sup>1</sup> @ 3x400VAC                    | N (lbf)                                    |  | 1120 (252)                     |
| Max. Cont. Force [Passive cooling / Fan / Fluid]      | N (lbf)                                    |  | 130 / 200 / 350 (29 / 45 / 79) |
| Max. Border Force relative                            | %  |  | 100                            |
| Force Constant 1                                      | N/A <sub>pk</sub> (lbf/A <sub>pk</sub> )   |  | 56 (12.6)                      |
| Force Constant 2                                      | N/A <sub>rms</sub> (lbf/A <sub>rms</sub> ) |  | 79.2 (17.8)                    |
| Velocity  |  |  |                                |
| Max. Velocity @ 1x230VAC                              | m/s (in/s)                                 |  | 3.2 (129.9)                    |
| Max. Velocity @ 3x400VAC                              | m/s (in/s)                                 |  | 5.6 (5.6)                      |
| Position Detection                                    |  |  |                                |
| Repeatability   | mm (in)                                    |  | ±0.05 (±0.002)                 |
| Linearity   | %  |  | ± 0.15                         |
| Electrical Data                                       |  |  |                                |
| Max. Current <sup>1</sup> @ 1x230VAC                  | A <sub>pk</sub> / A <sub>rms</sub>         |  | 19.9 / 14                      |
| Max. Current <sup>1</sup> @ 3x400VAC                  | A <sub>pk</sub> / A <sub>rms</sub>         |  | 19.9 / 14                      |
| Max. Cont. Current 1 [Passive cooling / Fan / Fluid]  | A <sub>pk</sub>                            |  | 2.3 / 3.6 / 6.3                |
| Max. Cont. Current 2 [Passive cooling / Fan / Fluid]  | A <sub>rms</sub>                           |  | 1.7 / 2.5 / 4.4                |
| Thermal Data  |  |  |                                |
| Max. Winding Temperature (Sensor)                     | °C   |  | 90                             |
| Thermal Resistance [Passive cooling / Fan / Fluid]    | °K/W                                       |  | 1.3 / 0.56 / 0.18              |
| Thermal Time Constant [Passive cooling / Fan / Fluid] | s  |  | 2100 / 500 / 110               |
| Mechanical Data                                       |  |  |                                |
| Slider Length   | mm (in)                                    |  | 1390 (55)                      |
| Slider Mass   | g (lb)                                     |  | 6530 (14.37)                   |

1) Real time calculation of motor winding temperature is required (including monitoring).  
 If temperature monitoring is only based on temperature sensor signal (missing thermal model calculation), 60 % of the peak value has to be taken instead.

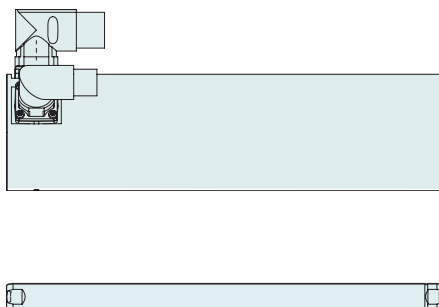

| Item                           | Description  | Item-No.                  |
|--------------------------------|--|---------------------------|
| <b>PS10-70x160U-BL-QJ</b>      | Stator 3x400VAC, LinMot Encoder                    | <a href="#">0150-1292</a> |
| <b>PS10-70x160U-BL-QJ-D04</b>  | Stator 3x400VAC, Sin/Cos Encoder 1Vpp, Pt1000 dual | <a href="#">0150-4261</a> |
| <b>PS10-70x160U-BL-QJ-D05</b>  | Stator 3x400VAC, Sin/Cos Encoder 1Vpp, PTC dual    | <a href="#">0150-4606</a> |
| <b>PS10-70x160U-BL-QJ-D08</b>  | Stator 3x400VAC, Sin/Cos Encoder 1Vpp, KTY dual    | <a href="#">0150-4511</a> |
| <b>PS10-70x160U-BL-QJ-D24</b>  | Stator 3x400VAC, A/B Encoder 1µm, Pt1000 dual      | <a href="#">0150-4131</a> |
| <b>PS10-70x160U-BL-QJ-D24S</b> | Stator 3x400VAC, A/B Encoder 5µm, Pt1000 dual      | <a href="#">0150-4596</a> |
| <b>PS10-70x160U-BL-QJ-D25</b>  | Stator 3x400VAC, A/B Encoder 1µm, PTC dual         | <a href="#">0150-5761</a> |
| <b>PS10-70x160U-BL-QJ-D25S</b> | Stator 3x400VAC, A/B Encoder 5µm, PTC dual         | <a href="#">0150-4601</a> |
| <b>PS10-70x160U-BL-QJ-D26</b>  | Stator 3x400VAC, A/B Encoder 1µm, PTC single ended | <a href="#">0150-4515</a> |
| <b>PS10-70x160U-BL-QJ-D34</b>  | Stator 3x400VAC, BiSS-C, Pt1000 dual               | <a href="#">0150-4871</a> |
| <b>PL10-28x1390/1340</b>       | Slider for P10-70 'standard'                       | <a href="#">0150-2205</a> |

**P10-70x160U/1290-BL-QJ**

**Max. Stroke:** 1290 mm  
**Peak Force:** 1120 N

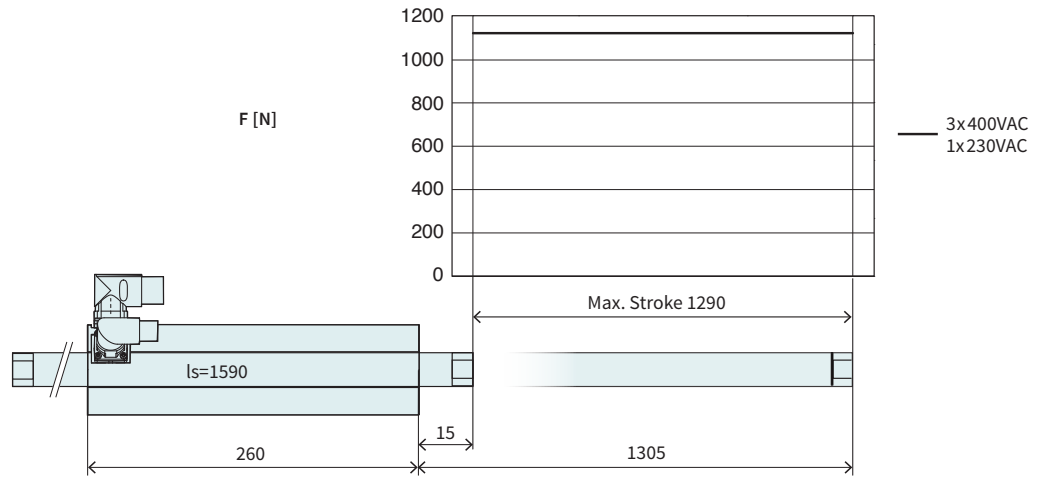

Dimensions in mm

| Stroke  |  |  |                                |
|---|--|--|--------------------------------|
| Max. Stroke   | mm (in)                                    |  | 1290 (50.79)                   |
| Force   |  |  |                                |
| Max. Force <sup>1</sup> @ 1x230VAC                    | N (lbf)                                    |  | 1120 (252)                     |
| Max. Force <sup>1</sup> @ 3x400VAC                    | N (lbf)                                    |  | 1120 (252)                     |
| Max. Cont. Force [Passive cooling / Fan / Fluid]      | N (lbf)                                    |  | 130 / 200 / 350 (29 / 45 / 79) |
| Max. Border Force relative                            | %  |  | 100                            |
| Force Constant 1                                      | N/A <sub>pk</sub> (lbf/A <sub>pk</sub> )   |  | 56 (12.6)                      |
| Force Constant 2                                      | N/A <sub>rms</sub> (lbf/A <sub>rms</sub> ) |  | 79.2 (17.8)                    |
| Velocity  |  |  |                                |
| Max. Velocity @ 1x230VAC                              | m/s (in/s)                                 |  | 3.2 (129.9)                    |
| Max. Velocity @ 3x400VAC                              | m/s (in/s)                                 |  | 5.6 (5.6)                      |
| Position Detection                                    |  |  |                                |
| Repeatability   | mm (in)                                    |  | ±0.05 (±0.002)                 |
| Linearity   | %  |  | ±0.15                          |
| Electrical Data                                       |  |  |                                |
| Max. Current <sup>1</sup> @ 1x230VAC                  | A <sub>pk</sub> / A <sub>rms</sub>         |  | 19.9 / 14                      |
| Max. Current <sup>1</sup> @ 3x400VAC                  | A <sub>pk</sub> / A <sub>rms</sub>         |  | 19.9 / 14                      |
| Max. Cont. Current 1 [Passive cooling / Fan / Fluid]  | A <sub>pk</sub>                            |  | 2.3 / 3.6 / 6.3                |
| Max. Cont. Current 2 [Passive cooling / Fan / Fluid]  | A <sub>rms</sub>                           |  | 1.7 / 2.5 / 4.4                |
| Thermal Data  |  |  |                                |
| Max. Winding Temperature (Sensor)                     | °C   |  | 90                             |
| Thermal Resistance [Passive cooling / Fan / Fluid]    | °K/W                                       |  | 1.3 / 0.56 / 0.18              |
| Thermal Time Constant [Passive cooling / Fan / Fluid] | s  |  | 2100 / 500 / 110               |
| Mechanical Data                                       |  |  |                                |
| Slider Length   | mm (in)                                    |  | 1590 (63)                      |
| Slider Mass   | g (lb)                                     |  | 7470 (16.43)                   |

<sup>1</sup> Real time calculation of motor winding temperature is required (including monitoring).  
 If temperature monitoring is only based on temperature sensor signal (missing thermal model calculation), 60 % of the peak value has to be taken instead.



| Item                           | Description  | Item-No.                  |
|--------------------------------|--|---------------------------|
| <b>PS10-70x160U-BL-QJ</b>      | Stator 3x400VAC, LinMot Encoder                    | <a href="#">0150-1292</a> |
| <b>PS10-70x160U-BL-QJ-D04</b>  | Stator 3x400VAC, Sin/Cos Encoder 1Vpp, Pt1000 dual | <a href="#">0150-4261</a> |
| <b>PS10-70x160U-BL-QJ-D05</b>  | Stator 3x400VAC, Sin/Cos Encoder 1Vpp, PTC dual    | <a href="#">0150-4606</a> |
| <b>PS10-70x160U-BL-QJ-D08</b>  | Stator 3x400VAC, Sin/Cos Encoder 1Vpp, KTY dual    | <a href="#">0150-4511</a> |
| <b>PS10-70x160U-BL-QJ-D24</b>  | Stator 3x400VAC, A/B Encoder 1µm, Pt1000 dual      | <a href="#">0150-4131</a> |
| <b>PS10-70x160U-BL-QJ-D24S</b> | Stator 3x400VAC, A/B Encoder 5µm, Pt1000 dual      | <a href="#">0150-4596</a> |
| <b>PS10-70x160U-BL-QJ-D25</b>  | Stator 3x400VAC, A/B Encoder 1µm, PTC dual         | <a href="#">0150-5761</a> |
| <b>PS10-70x160U-BL-QJ-D25S</b> | Stator 3x400VAC, A/B Encoder 5µm, PTC dual         | <a href="#">0150-4601</a> |
| <b>PS10-70x160U-BL-QJ-D26</b>  | Stator 3x400VAC, A/B Encoder 1µm, PTC single ended | <a href="#">0150-4515</a> |
| <b>PS10-70x160U-BL-QJ-D34</b>  | Stator 3x400VAC, BiSS-C, Pt1000 dual               | <a href="#">0150-4871</a> |
| <b>PL10-28x1590/1540</b>       | Slider for P10-70 'standard'                       | <a href="#">0150-2206</a> |

**P10-70x160U/1490-BL-QJ**

**Max. Stroke:** 1490 mm  
**Peak Force:** 1120 N

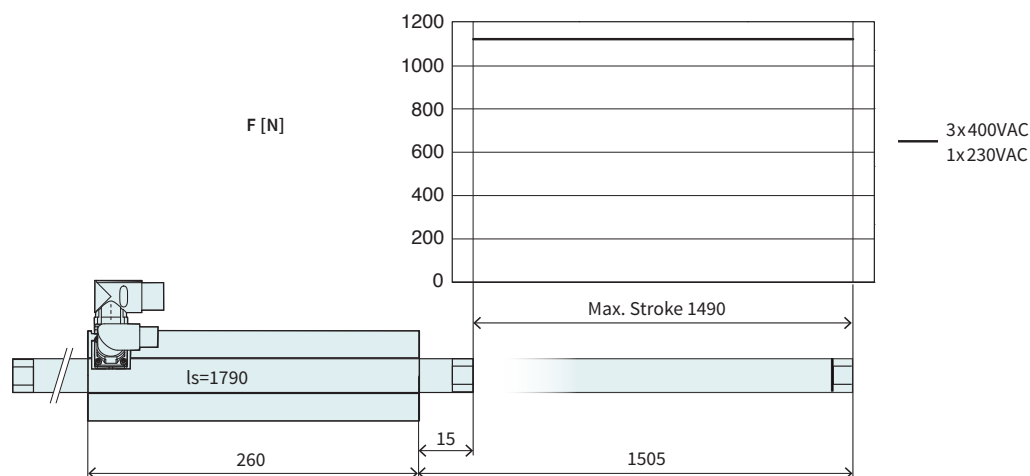

Dimensions in mm

| Stroke  |  |  |                                |
|---|--|--|--------------------------------|
| Max. Stroke   | mm (in)                                    |  | 1490 (58.7)                    |
| Force   |  |  |                                |
| Max. Force <sup>1</sup> @ 1x230VAC                    | N (lbf)                                    |  | 1120 (252)                     |
| Max. Force <sup>1</sup> @ 3x400VAC                    | N (lbf)                                    |  | 1120 (252)                     |
| Max. Cont. Force [Passive cooling / Fan / Fluid]      | N (lbf)                                    |  | 130 / 200 / 350 (29 / 45 / 79) |
| Max. Border Force relative                            | %  |  | 100                            |
| Force Constant 1                                      | N/A <sub>pk</sub> (lbf/A <sub>pk</sub> )   |  | 56 (12.6)                      |
| Force Constant 2                                      | N/A <sub>rms</sub> (lbf/A <sub>rms</sub> ) |  | 79.2 (17.8)                    |
| Velocity  |  |  |                                |
| Max. Velocity @ 1x230VAC                              | m/s (in/s)                                 |  | 3.2 (129.9)                    |
| Max. Velocity @ 3x400VAC                              | m/s (in/s)                                 |  | 5.6 (5.6)                      |
| Position Detection                                    |  |  |                                |
| Repeatability   | mm (in)                                    |  | ±0.05 (±0.002)                 |
| Linearity   | %  |  | ± 0.15                         |
| Electrical Data                                       |  |  |                                |
| Max. Current <sup>1</sup> @ 1x230VAC                  | A <sub>pk</sub> / A <sub>rms</sub>         |  | 19.9 / 14                      |
| Max. Current <sup>1</sup> @ 3x400VAC                  | A <sub>pk</sub> / A <sub>rms</sub>         |  | 19.9 / 14                      |
| Max. Cont. Current 1 [Passive cooling / Fan / Fluid]  | A <sub>pk</sub>                            |  | 2.3 / 3.6 / 6.3                |
| Max. Cont. Current 2 [Passive cooling / Fan / Fluid]  | A <sub>rms</sub>                           |  | 1.7 / 2.5 / 4.4                |
| Thermal Data  |  |  |                                |
| Max. Winding Temperature (Sensor)                     | °C   |  | 90                             |
| Thermal Resistance [Passive cooling / Fan / Fluid]    | °K/W                                       |  | 1.3 / 0.56 / 0.18              |
| Thermal Time Constant [Passive cooling / Fan / Fluid] | s  |  | 2100 / 500 / 110               |
| Mechanical Data                                       |  |  |                                |
| Slider Length   | mm (in)                                    |  | 1790 (70)                      |
| Slider Mass   | g (lb)                                     |  | 8413 (18.51)                   |

1) Real time calculation of motor winding temperature is required (including monitoring).  
 If temperature monitoring is only based on temperature sensor signal (missing thermal model calculation), 60 % of the peak value has to be taken instead.



| Item                           | Description  | Item-No.                  |
|--------------------------------|--|---------------------------|
| <b>PS10-70x160U-BL-QJ</b>      | Stator 3x400VAC, LinMot Encoder                    | <a href="#">0150-1292</a> |
| <b>PS10-70x160U-BL-QJ-D04</b>  | Stator 3x400VAC, Sin/Cos Encoder 1Vpp, Pt1000 dual | <a href="#">0150-4261</a> |
| <b>PS10-70x160U-BL-QJ-D05</b>  | Stator 3x400VAC, Sin/Cos Encoder 1Vpp, PTC dual    | <a href="#">0150-4606</a> |
| <b>PS10-70x160U-BL-QJ-D08</b>  | Stator 3x400VAC, Sin/Cos Encoder 1Vpp, KTY dual    | <a href="#">0150-4511</a> |
| <b>PS10-70x160U-BL-QJ-D24</b>  | Stator 3x400VAC, A/B Encoder 1µm, Pt1000 dual      | <a href="#">0150-4131</a> |
| <b>PS10-70x160U-BL-QJ-D24S</b> | Stator 3x400VAC, A/B Encoder 5µm, Pt1000 dual      | <a href="#">0150-4596</a> |
| <b>PS10-70x160U-BL-QJ-D25</b>  | Stator 3x400VAC, A/B Encoder 1µm, PTC dual         | <a href="#">0150-5761</a> |
| <b>PS10-70x160U-BL-QJ-D25S</b> | Stator 3x400VAC, A/B Encoder 5µm, PTC dual         | <a href="#">0150-4601</a> |
| <b>PS10-70x160U-BL-QJ-D26</b>  | Stator 3x400VAC, A/B Encoder 1µm, PTC single ended | <a href="#">0150-4515</a> |
| <b>PS10-70x160U-BL-QJ-D34</b>  | Stator 3x400VAC, BiSS-C, Pt1000 dual               | <a href="#">0150-4871</a> |
| <b>PL10-28x1790/1740</b>       | Slider for P10-70 'standard'                       | <a href="#">0150-2207</a> |

**P10-70x160U/1690-BL-QJ**

**Max. Stroke:** 1690 mm  
**Peak Force:** 1120 N

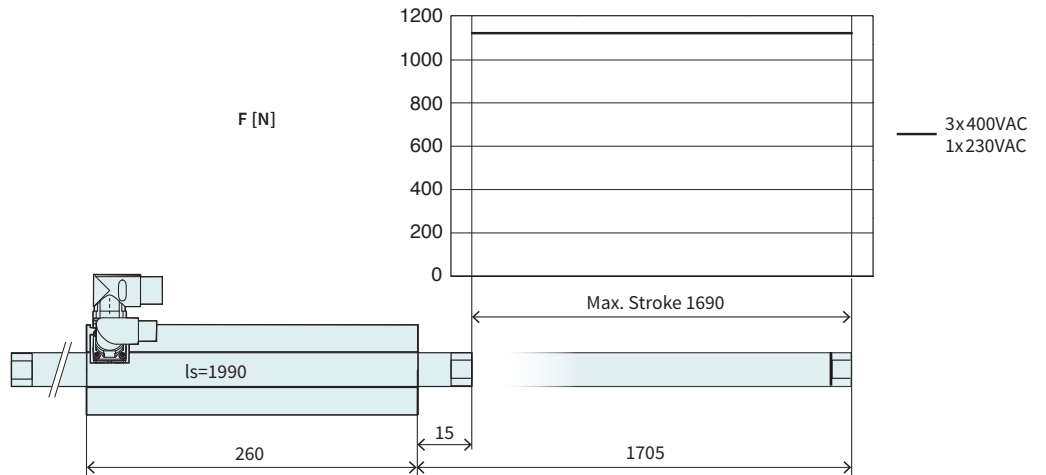

Dimensions in mm

| Stroke  |  |                   |                |
|---|--|-------------------|----------------|
| Max. Stroke   | mm (in)                                    | 1690              | (66.49)        |
| Force   |  |                   |                |
| Max. Force <sup>1</sup> @ 1x230VAC                    | N (lbf)                                    | 1120              | (252)          |
| Max. Force <sup>1</sup> @ 3x400VAC                    | N (lbf)                                    | 1120              | (252)          |
| Max. Cont. Force [Passive cooling / Fan / Fluid]      | N (lbf)                                    | 130 / 200 / 350   | (29 / 45 / 79) |
| Max. Border Force relative                            | %  | 100               |                |
| Force Constant 1                                      | N/A <sub>pk</sub> (lbf/A <sub>pk</sub> )   | 56                | (12.6)         |
| Force Constant 2                                      | N/A <sub>rms</sub> (lbf/A <sub>rms</sub> ) | 79.2              | (17.8)         |
| Velocity  |  |                   |                |
| Max. Velocity @ 1x230VAC                              | m/s (in/s)                                 | 3.2               | (129.9)        |
| Max. Velocity @ 3x400VAC                              | m/s (in/s)                                 | 5.6               | (5.6)          |
| Position Detection                                    |  |                   |                |
| Repeatability   | mm (in)                                    | ±0.05             | (±0.002)       |
| Linearity   | %  | ±0.15             |                |
| Electrical Data                                       |  |                   |                |
| Max. Current <sup>1</sup> @ 1x230VAC                  | A <sub>pk</sub> / A <sub>rms</sub>         | 19.9 / 14         |                |
| Max. Current <sup>1</sup> @ 3x400VAC                  | A <sub>pk</sub> / A <sub>rms</sub>         | 19.9 / 14         |                |
| Max. Cont. Current 1 [Passive cooling / Fan / Fluid]  | A <sub>pk</sub>                            | 2.3 / 3.6 / 6.3   |                |
| Max. Cont. Current 2 [Passive cooling / Fan / Fluid]  | A <sub>rms</sub>                           | 1.7 / 2.5 / 4.4   |                |
| Thermal Data  |  |                   |                |
| Max. Winding Temperature (Sensor)                     | °C   | 90                |                |
| Thermal Resistance [Passive cooling / Fan / Fluid]    | °K/W                                       | 1.3 / 0.56 / 0.18 |                |
| Thermal Time Constant [Passive cooling / Fan / Fluid] | s  | 2100 / 500 / 110  |                |
| Mechanical Data                                       |  |                   |                |
| Slider Length   | mm (in)                                    | 1990              | (78)           |
| Slider Mass   | g (lb)                                     | 9350              | (20.57)        |

<sup>1</sup> Real time calculation of motor winding temperature is required (including monitoring).  
 If temperature monitoring is only based on temperature sensor signal (missing thermal model calculation), 60 % of the peak value has to be taken instead.



| Item                           | Description  | Item-No.                  |
|--------------------------------|--|---------------------------|
| <b>PS10-70x160U-BL-QJ</b>      | Stator 3x400VAC, LinMot Encoder                    | <a href="#">0150-1292</a> |
| <b>PS10-70x160U-BL-QJ-D04</b>  | Stator 3x400VAC, Sin/Cos Encoder 1Vpp, Pt1000 dual | <a href="#">0150-4261</a> |
| <b>PS10-70x160U-BL-QJ-D05</b>  | Stator 3x400VAC, Sin/Cos Encoder 1Vpp, PTC dual    | <a href="#">0150-4606</a> |
| <b>PS10-70x160U-BL-QJ-D08</b>  | Stator 3x400VAC, Sin/Cos Encoder 1Vpp, KTY dual    | <a href="#">0150-4511</a> |
| <b>PS10-70x160U-BL-QJ-D24</b>  | Stator 3x400VAC, A/B Encoder 1µm, Pt1000 dual      | <a href="#">0150-4131</a> |
| <b>PS10-70x160U-BL-QJ-D24S</b> | Stator 3x400VAC, A/B Encoder 5µm, Pt1000 dual      | <a href="#">0150-4596</a> |
| <b>PS10-70x160U-BL-QJ-D25</b>  | Stator 3x400VAC, A/B Encoder 1µm, PTC dual         | <a href="#">0150-5761</a> |
| <b>PS10-70x160U-BL-QJ-D25S</b> | Stator 3x400VAC, A/B Encoder 5µm, PTC dual         | <a href="#">0150-4601</a> |
| <b>PS10-70x160U-BL-QJ-D26</b>  | Stator 3x400VAC, A/B Encoder 1µm, PTC single ended | <a href="#">0150-4515</a> |
| <b>PS10-70x160U-BL-QJ-D34</b>  | Stator 3x400VAC, BiSS-C, Pt1000 dual               | <a href="#">0150-4871</a> |
| <b>PL10-28x1990/1940</b>       | Slider for P10-70 'standard'                       | <a href="#">0150-2208</a> |

Linear Guides H10

4



HM10-70x160/90 | Linear Module 70x160 with 90 mm Stroke

|   |                        |                                      |   |  |                           |
|---|------------------------|--------------------------------------|---|--|---------------------------|
| → | H-Guide                | H10-70x160/90                        | H-Guide for P10-70x160, Stroke max. 90 mm | <a href="#">0150-5409</a>                          |                           |
|   | →                      | Stator                               | PS10-70x160U-BL-QJ                        | Stator 3x400VAC, LinMot Encoder                    | <a href="#">0150-1292</a> |
|   |                        |                                      | PS10-70x160U-BL-QJ-D04                    | Stator 3x400VAC, Sin/Cos Encoder 1Vpp, Pt1000 dual | <a href="#">0150-4261</a> |
|   |                        |                                      | PS10-70x160U-BL-QJ-D05                    | Stator 3x400VAC, Sin/Cos Encoder 1Vpp, PTC dual    | <a href="#">0150-4606</a> |
|   |                        |                                      | PS10-70x160U-BL-QJ-D08                    | Stator 3x400VAC, Sin/Cos Encoder 1Vpp, KTY dual    | <a href="#">0150-4511</a> |
|   |                        |                                      | PS10-70x160U-BL-QJ-D24                    | Stator 3x400VAC, A/B Encoder 1µm, Pt1000 dual      | <a href="#">0150-4131</a> |
|   |                        |                                      | PS10-70x160U-BL-QJ-D24S                   | Stator 3x400VAC, A/B Encoder 5µm, Pt1000 dual      | <a href="#">0150-4596</a> |
|   |                        |                                      | PS10-70x160U-BL-QJ-D25                    | Stator 3x400VAC, A/B Encoder 1µm, PTC dual         | <a href="#">0150-5761</a> |
|   |                        |                                      | PS10-70x160U-BL-QJ-D25S                   | Stator 3x400VAC, A/B Encoder 5µm, PTC dual         | <a href="#">0150-4601</a> |
|   |                        |                                      | PS10-70x160U-BL-QJ-D26                    | Stator 3x400VAC, A/B Encoder 1µm, PTC single ended | <a href="#">0150-4515</a> |
|   | PS10-70x160U-BL-QJ-D34 | Stator 3x400VAC, BiSS-C, Pt1000 dual | <a href="#">0150-4871</a>                 |  |                           |
| → | Slider                 | PL10-28x390/340                      | Slider for P10-70 'standard'              | <a href="#">0150-Y2194</a>                         |                           |

HM10-70x160/190 | Linear Module 70x160 with 190 mm Stroke

|   |                        |                                      |  |  |                           |
|---|------------------------|--------------------------------------|--|--|---------------------------|
| → | H-Guide                | H10-70x160/190                       | H-Guide for P10-70x160, Stroke max. 190 mm | <a href="#">0150-5410</a>                          |                           |
|   | →                      | Stator                               | PS10-70x160U-BL-QJ                         | Stator 3x400VAC, LinMot Encoder                    | <a href="#">0150-1292</a> |
|   |                        |                                      | PS10-70x160U-BL-QJ-D04                     | Stator 3x400VAC, Sin/Cos Encoder 1Vpp, Pt1000 dual | <a href="#">0150-4261</a> |
|   |                        |                                      | PS10-70x160U-BL-QJ-D05                     | Stator 3x400VAC, Sin/Cos Encoder 1Vpp, PTC dual    | <a href="#">0150-4606</a> |
|   |                        |                                      | PS10-70x160U-BL-QJ-D08                     | Stator 3x400VAC, Sin/Cos Encoder 1Vpp, KTY dual    | <a href="#">0150-4511</a> |
|   |                        |                                      | PS10-70x160U-BL-QJ-D24                     | Stator 3x400VAC, A/B Encoder 1µm, Pt1000 dual      | <a href="#">0150-4131</a> |
|   |                        |                                      | PS10-70x160U-BL-QJ-D24S                    | Stator 3x400VAC, A/B Encoder 5µm, Pt1000 dual      | <a href="#">0150-4596</a> |
|   |                        |                                      | PS10-70x160U-BL-QJ-D25                     | Stator 3x400VAC, A/B Encoder 1µm, PTC dual         | <a href="#">0150-5761</a> |
|   |                        |                                      | PS10-70x160U-BL-QJ-D25S                    | Stator 3x400VAC, A/B Encoder 5µm, PTC dual         | <a href="#">0150-4601</a> |
|   |                        |                                      | PS10-70x160U-BL-QJ-D26                     | Stator 3x400VAC, A/B Encoder 1µm, PTC single ended | <a href="#">0150-4515</a> |
|   | PS10-70x160U-BL-QJ-D34 | Stator 3x400VAC, BiSS-C, Pt1000 dual | <a href="#">0150-4871</a>                  |  |                           |
| → | Slider                 | PL10-28x490/440                      | Slider for P10-70 'standard'               | <a href="#">0150-2195</a>                          |                           |

| HM10-70x160/290 |         | Linear Module 70x160 with 290 mm Stroke |  |                           |
|-----------------|---------|---|--|---------------------------|
| →               | H-Guide | H10-70x160/290                          | H-Guide for P10-70x160, Stroke max. 290 mm         | <a href="#">0150-5411</a> |
| →               | Stator  | PS10-70x160U-BL-QJ                      | Stator 3x400VAC, LinMot Encoder                    | <a href="#">0150-1292</a> |
|                 |         | PS10-70x160U-BL-QJ-D04                  | Stator 3x400VAC, Sin/Cos Encoder 1Vpp, Pt1000 dual | <a href="#">0150-4261</a> |
|                 |         | PS10-70x160U-BL-QJ-D05                  | Stator 3x400VAC, Sin/Cos Encoder 1Vpp, PTC dual    | <a href="#">0150-4606</a> |
|                 |         | PS10-70x160U-BL-QJ-D08                  | Stator 3x400VAC, Sin/Cos Encoder 1Vpp, KTY dual    | <a href="#">0150-4511</a> |
|                 |         | PS10-70x160U-BL-QJ-D24                  | Stator 3x400VAC, A/B Encoder 1µm, Pt1000 dual      | <a href="#">0150-4131</a> |
|                 |         | PS10-70x160U-BL-QJ-D24S                 | Stator 3x400VAC, A/B Encoder 5µm, Pt1000 dual      | <a href="#">0150-4596</a> |
|                 |         | PS10-70x160U-BL-QJ-D25                  | Stator 3x400VAC, A/B Encoder 1µm, PTC dual         | <a href="#">0150-5761</a> |
|                 |         | PS10-70x160U-BL-QJ-D25S                 | Stator 3x400VAC, A/B Encoder 5µm, PTC dual         | <a href="#">0150-4601</a> |
|                 |         | PS10-70x160U-BL-QJ-D26                  | Stator 3x400VAC, A/B Encoder 1µm, PTC single ended | <a href="#">0150-4515</a> |
|                 |         | PS10-70x160U-BL-QJ-D34                  | Stator 3x400VAC, BiSS-C, Pt1000 dual               | <a href="#">0150-4871</a> |
| →               | Slider  | PL10-28x590/540                         | Slider für P10-70 'standard'                       | <a href="#">0150-2196</a> |

| HM10-70x160/390 |         | Linear Modul 70x160 with 390 mm Stroke |  |                           |
|-----------------|---------|--|--|---------------------------|
| →               | H-Guide | H10-70x160/390                         | H-Guide for P10-70x160, Stroke max. 390 mm         | <a href="#">0150-5412</a> |
| →               | Stator  | PS10-70x160U-BL-QJ                     | Stator 3x400VAC, LinMot Encoder                    | <a href="#">0150-1292</a> |
|                 |         | PS10-70x160U-BL-QJ-D04                 | Stator 3x400VAC, Sin/Cos Encoder 1Vpp, Pt1000 dual | <a href="#">0150-4261</a> |
|                 |         | PS10-70x160U-BL-QJ-D05                 | Stator 3x400VAC, Sin/Cos Encoder 1Vpp, PTC dual    | <a href="#">0150-4606</a> |
|                 |         | PS10-70x160U-BL-QJ-D08                 | Stator 3x400VAC, Sin/Cos Encoder 1Vpp, KTY dual    | <a href="#">0150-4511</a> |
|                 |         | PS10-70x160U-BL-QJ-D24                 | Stator 3x400VAC, A/B Encoder 1µm, Pt1000 dual      | <a href="#">0150-4131</a> |
|                 |         | PS10-70x160U-BL-QJ-D24S                | Stator 3x400VAC, A/B Encoder 5µm, Pt1000 dual      | <a href="#">0150-4596</a> |
|                 |         | PS10-70x160U-BL-QJ-D25                 | aStator 3x400VAC, A/B Encoder 1µm, PTC dual        | <a href="#">0150-5761</a> |
|                 |         | PS10-70x160U-BL-QJ-D25S                | Stator 3x400VAC, A/B Encoder 5µm, PTC dual         | <a href="#">0150-4601</a> |
|                 |         | PS10-70x160U-BL-QJ-D26                 | Stator 3x400VAC, A/B Encoder 1µm, PTC single ended | <a href="#">0150-4515</a> |
|                 |         | PS10-70x160U-BL-QJ-D34                 | Stator 3x400VAC, BiSS-C, Pt1000 dual               | <a href="#">0150-4871</a> |
| →               | Slider  | PL10-28x690/640                        | Slider for P10-70 'standard'                       | <a href="#">0150-2197</a> |

| HM10-70x160/490 |         | Linear Modul 70x160 with 490 mm Stroke |  |                           |
|-----------------|---------|--|--|---------------------------|
| →               | H-Guide | H10-70x160/490                         | H-Guide for P10-70x160, Stroke max. 490 mm         | <a href="#">0150-5413</a> |
| →               | Stator  | PS10-70x160U-BL-QJ                     | Stator 3x400VAC, LinMot Encoder                    | <a href="#">0150-1292</a> |
|                 |         | PS10-70x160U-BL-QJ-D04                 | Stator 3x400VAC, Sin/Cos Encoder 1Vpp, Pt1000 dual | <a href="#">0150-4261</a> |
|                 |         | PS10-70x160U-BL-QJ-D05                 | Stator 3x400VAC, Sin/Cos Encoder 1Vpp, PTC dual    | <a href="#">0150-4606</a> |
|                 |         | PS10-70x160U-BL-QJ-D08                 | Stator 3x400VAC, Sin/Cos Encoder 1Vpp, KTY dual    | <a href="#">0150-4511</a> |
|                 |         | PS10-70x160U-BL-QJ-D24                 | Stator 3x400VAC, A/B Encoder 1µm, Pt1000 dual      | <a href="#">0150-4131</a> |
|                 |         | PS10-70x160U-BL-QJ-D24S                | Stator 3x400VAC, A/B Encoder 5µm, Pt1000 dual      | <a href="#">0150-4596</a> |
|                 |         | PS10-70x160U-BL-QJ-D25                 | Stator 3x400VAC, A/B Encoder 1µm, PTC dual         | <a href="#">0150-5761</a> |
|                 |         | PS10-70x160U-BL-QJ-D25S                | Stator 3x400VAC, A/B Encoder 5µm, PTC dual         | <a href="#">0150-4601</a> |
|                 |         | PS10-70x160U-BL-QJ-D26                 | Stator 3x400VAC, A/B Encoder 1µm, PTC single ended | <a href="#">0150-4515</a> |
|                 |         | PS10-70x160U-BL-QJ-D34                 | Stator 3x400VAC, BiSS-C, Pt1000 dual               | <a href="#">0150-4871</a> |
| →               | Slider  | PL10-28x790/740                        | Slider for P10-70 'standard'                       | <a href="#">0150-2198</a> |

| Accessories |     |            |  |                           |
|-------------|-----|------------|--|---------------------------|
| →           | Fan | HV01-37/48 | Fan cooling for H01-37/48 & PF02-37/48 | <a href="#">0150-5051</a> |

**Motor Cable**

4



**C1400**

**B** Connector MC10-B/m

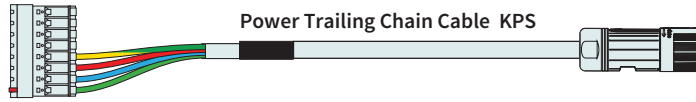

Power Trailing Chain Cable KPS

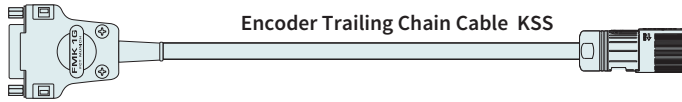

Encoder Trailing Chain Cable KSS

**Q** Connector MC10-Q/f

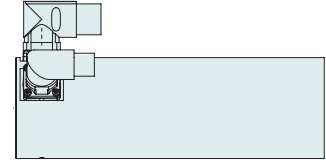

**P10-70x160U**

**D15** Connector MC01-D15/f

**J** Connector MC10-J/f



**E1400**

**L** Connector MC10-L/m

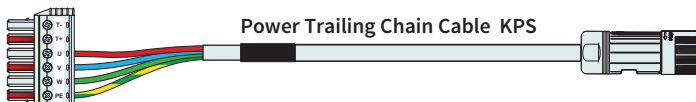

Power Trailing Chain Cable KPS

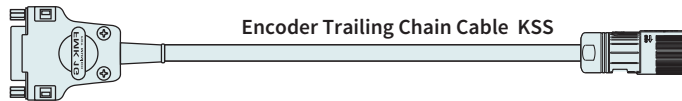

Encoder Trailing Chain Cable KSS

**Q** Connector MC10-Q/f

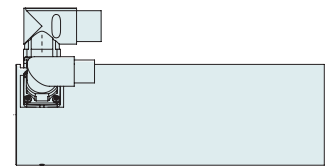

**P10-70x160U**

**D15** Connector MC01-D15/f

**J** Connector MC10-J/f

## ORDERING INFORMATION

| POWER CABLES                      |  |                           |
|-----------------------------------|--|---------------------------|
| Item                              | Description  | Item-No.                  |
| <b>KPS15-04-L/Q-3</b>             | Power Trailing Chain Cable E1400/P10-70, 3 m       | <a href="#">0150-2266</a> |
| <b>KPS15-04-L/Q-5</b>             | Power Trailing Chain Cable E1400/P10-70, 5 m       | <a href="#">0150-2261</a> |
| <b>KPS15-04-L/Q-8</b>             | Power Trailing Chain Cable E1400/P10-70, 8 m       | <a href="#">0150-2267</a> |
| <b>KPS15-04-L/Q-12</b>            | Power Trailing Chain Cable E1400/P10-70, 12 m      | <a href="#">0150-2268</a> |
| <b>KPS15-04-L/Q-</b>              | Power Trailing Chain Cable L/Q-, Custom length     | <a href="#">0150-3388</a> |
| <b>KPS15-04-B/Q-3</b>             | Power Trailing Chain Cable C1400/P10-70, 3 m       | <a href="#">0150-3660</a> |
| <b>KPS15-04-B/Q-5</b>             | Power Trailing Chain Cable C1400/P10-70, 5 m       | <a href="#">0150-3661</a> |
| <b>KPS15-04-B/Q-8</b>             | Power Trailing Chain Cable C1400/P10-70, 8 m       | <a href="#">0150-3662</a> |
| <b>KPS15-04-B/Q-12</b>            | Power Trailing Chain Cable C1400/P10-70, 12 m      | <a href="#">0150-3663</a> |
| <b>KPS15-04-B/Q-</b>              | Power Trailing Chain Cable B/Q-, Custom length     | <a href="#">0150-3608</a> |
| ENCODER CABLES                    |  |                           |
| Item                              | Description  | Item-No.                  |
| <b>KSS 05-02/08-D15/J-3</b>       | Encoder Trailing Chain Cable D15/J, 3 m            | <a href="#">0150-2263</a> |
| <b>KSS 05-02/08-D15/J-5</b>       | Encoder Trailing Chain Cable D15/J, 5 m            | <a href="#">0150-2262</a> |
| <b>KSS 05-02/08-D15/J-8</b>       | Encoder Trailing Chain Cable D15/J, 8 m            | <a href="#">0150-2264</a> |
| <b>KSS 05-02/08-D15/J-12</b>      | Encoder Trailing Chain Cable D15/J, 12 m           | <a href="#">0150-2265</a> |
| <b>KSS 05-02/08-D15(f)-45°/J-</b> | Encoder Trailing Chain Cable D15/J-, Custom length | <a href="#">0150-3389</a> |
| EXTENSION CABLES                  |  |                           |
| Item                              | Description  | Item-No.                  |
| <b>KPS15-04-Q/Q-</b>              | Power Trailing Chain Cable Q/Q-, Custom length     | <a href="#">0150-3414</a> |
| <b>KSS05-02/08-J/J-</b>           | Encoder Trailing Chain Cable J/J-, Custom length   | <a href="#">0150-3415</a> |
| CONNECTORS                        |  |                           |
| Item                              | Description  | Item-No.                  |
| <b>MC10-L/m</b>                   | Connector Power E1400/X2                           | <a href="#">0150-3382</a> |
| <b>MC01-D15/f</b>                 | Motor Connector D15 (f)                            | <a href="#">0150-3136</a> |
| <b>MC10-Q/f</b>                   | Connector Power PS10-70                            | <a href="#">0150-2268</a> |
| <b>MC10-J/f</b>                   | Connector Encoder PS10-70                          | <a href="#">0150-2269</a> |

**Motor Cables for 3rd Party Drives**

4

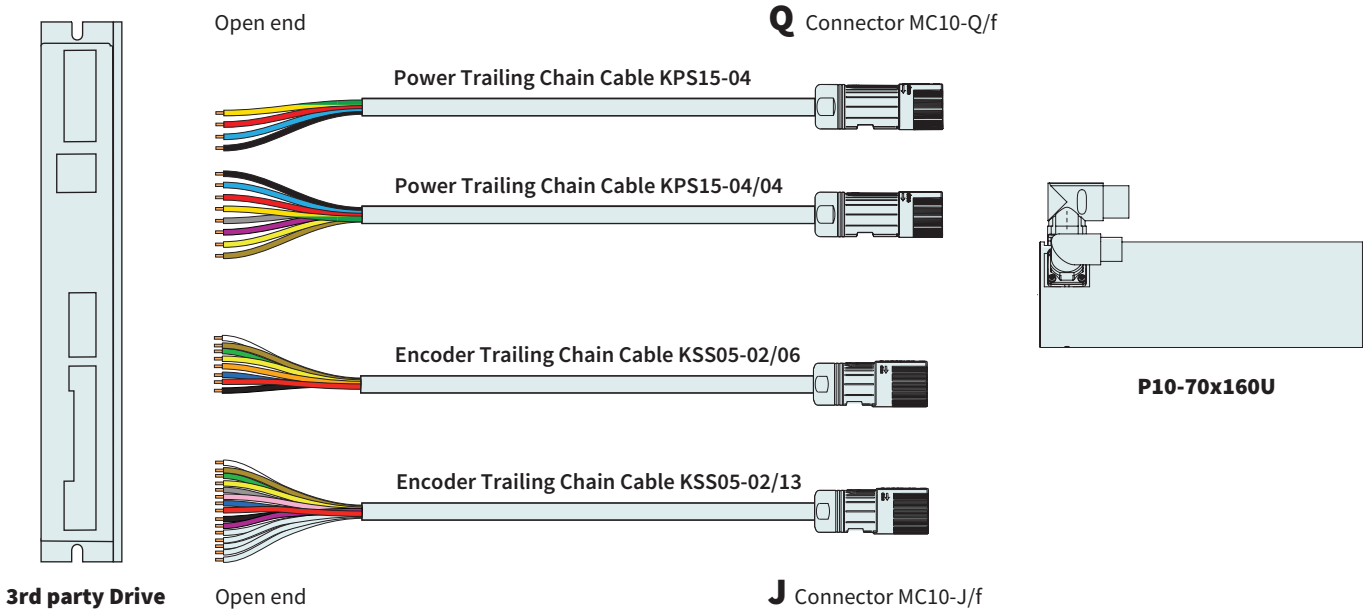

**ORDER OVERVIEW**

| Motor-Interface          | Power Cable         |                    | Encoder Cable       |                    |                    |                  |                |
|--------------------------|---------------------|--------------------|---------------------|--------------------|--------------------|------------------|----------------|
|                          |                     | TempFeedback       |                     | TempFeedback       | Hallswitch Signals | Reference Signal | PosFeedback    |
| D04 / D05 / D08          | KPS15-04-_/Q-...    | ---                | KSS05-02/13-_/J-... | Pt1000 / PTC / KTY | Hall U/V/W         | Ref              | Sin/Cos        |
|                          | KPS15-04/04-_/Q-... | Pt1000 / PTC / KTY | KSS05-02/06-_/J-... | ---                | ---                | ---              |                |
| D24(S) / D25(S)<br>/ D26 | KPS15-04-_/Q-...    | ---                | KSS05-02/13-_/J-... | Pt1000 / PTC       | Hall U/V/W         | Ref              | AB 1 µm (5 µm) |
|                          | KPS15-04/04-_/Q-... | Pt1000 / PTC       | KSS05-02/06-_/J-... | ---                | ---                | ---              |                |
| D34                      | KPS15-04-_/Q-...    | ---                | KSS05-02/13-_/J-... | Pt1000             | Hall U/V/W         | Ref              | BiSS-C         |
|                          | KPS15-04/04-_/Q-... | Pt1000             |                     |                    |                    |                  |                |

## ORDERING INFORMATION

| POWER CABLES               |  |                           |
|----------------------------|--|---------------------------|
| Item                       | Description  | Item-No.                  |
| <b>KPS15-04-.../Q-10</b>   | Power Trailing Chain Cable .../Q, 10 m for Dxx           | <a href="#">0150-2376</a> |
| <b>KPS15-04-./Q-</b>       | Power Trailing Chain Cable .../Q, für Dxx, Custom length | <a href="#">0150-3491</a> |
| <b>KPS15-04</b>            | Power Trailing Chain Cable P10-70 (per m)                | <a href="#">0150-2257</a> |
| <b>KPS15-04/04.../Q-10</b> | Power Trailing Chain Cable .../Q, 10 m for Dxx           | <a href="#">0150-3654</a> |
| <b>KPS15-04/04-./Q-</b>    | Power Trailing Chain Cable .../Q, für Dxx, Custom length | <a href="#">0150-3579</a> |
| <b>KPS15-04/04</b>         | Power Trailing Chain Cable P10-...-Dxx (per m)           | <a href="#">0150-2269</a> |

| ENCODER CABLES              |  |                           |
|-----------------------------|--|---------------------------|
| Item                        | Description  | Item-No.                  |
| <b>KSS05-02/13-.../J-10</b> | Encoder Trailing Chain Cable .../J, 10 m for Dxx         | <a href="#">0150-2377</a> |
| <b>KSS05-02/13-./J-</b>     | Encoder Trailing Chain Cable ./J, für Dxx, Custom length | <a href="#">0150-3492</a> |
| <b>KSS05-02/13</b>          | Encoder Trailing Chain Cable P10-...-Dxx (per m)         | <a href="#">0150-2259</a> |

| EXTENSION CABLES        |  |                           |
|-------------------------|--|---------------------------|
| Item                    | Description  | Item-No.                  |
| <b>KPS15-04-Q/Q-</b>    | Power Trailing Chain Cable Q/Q-, Custom length           | <a href="#">0150-3414</a> |
| <b>KPS15-04/04-Q/Q-</b> | Power Trailing Chain Cable Q/Q-, Custom length           | <a href="#">0150-4214</a> |
| <b>KSS05-02/13-J/J-</b> | Encoder Trailing Chain Cable J/J, für Dxx, Custom length | <a href="#">0150-3996</a> |

| CONNECTORS      |                           |                           |
|-----------------|---------------------------|---------------------------|
| Item            | Description               | Item-No.                  |
| <b>MC10-Q/f</b> | Connector Power PS10-70   | <a href="#">0150-2268</a> |
| <b>MC10-J/f</b> | Connector Encoder PS10-70 | <a href="#">0150-2269</a> |

**MOTOR FLANGES**

4



| Item        | Description            | Item-No.                  |
|-------------|------------------------|---------------------------|
| PF10-70x190 | Flange for PS10-70x160 | <a href="#">0150-2273</a> |



| Item           | Description                          | Item-No.                  |
|----------------|--------------------------------------|---------------------------|
| PF11-70x190-FC | Flange for PS10-70x160 fluid cooling | <a href="#">0150-2823</a> |

FIND MORE PRODUCT DETAILS IN THE CHAPTER "ACCESSORIES".

**FANS**



| Item       | Description                            | Item-No.                  |
|------------|--|---------------------------|
| HV01-37/48 | Fan cooling for H01-37/48 & PF02-37/48 | <a href="#">0150-5051</a> |

FIND MORE PRODUCT DETAILS IN THE CHAPTER "ACCESSORIES".

**SLIDER MOUNTING**



| Item               | Description   | Item-No.                  |
|--------------------|---|---------------------------|
| <b>PLF01-28</b>    | Fixed Bearing Set for 27/28 mm sliders                  | <a href="#">0150-3087</a> |
| <b>PLF01-28-SS</b> | Fixed Bearing Set for 27/28 mm sliders, stainless steel | <a href="#">0150-3297</a> |
| <b>PLL01-28</b>    | Floating Bearing for 28 mm sliders                      | <a href="#">0150-3094</a> |
| <b>PLM01-28-MK</b> | Mounting Kit for 28 mm sliders                          | <a href="#">0150-3095</a> |

FIND MORE PRODUCT DETAILS IN THE CHAPTER "ACCESSORIES".

**BEARING KIT**



| Item                 | Description                 | Item-No.                  |
|----------------------|-----------------------------|---------------------------|
| <b>PB10-70x160-L</b> | Bearing Kit for PS10-70x160 | <a href="#">0150-3432</a> |

FIND MORE PRODUCT DETAILS IN THE CHAPTER "ACCESSORIES".

**LUBRICANT RESERVOIR**



| Item              | Description   | Item-No.                  |
|-------------------|---|---------------------------|
| <b>PA10-70/28</b> | Lubricant reservoir for PS10-70 with lubricating nipple | <a href="#">0150-3543</a> |

FIND MORE PRODUCT DETAILS IN THE CHAPTER "ACCESSORIES".

**EXTERNAL POSITION SENSORS**

4

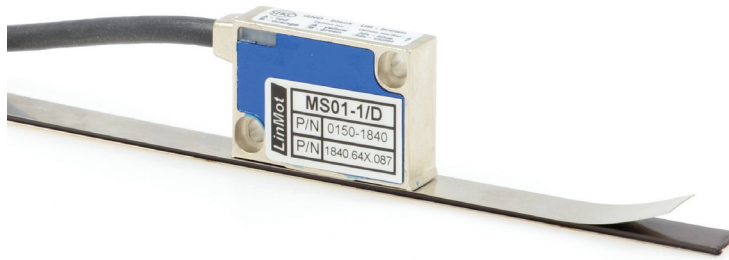

| Item                       | Description                                     | Item-No.                  |
|----------------------------|---|---------------------------|
| <b>MS01-1/D</b>            | Linear Encoder 1µm, A/B (for incremental strip) | <a href="#">0150-1840</a> |
| <b>MB01-1000</b>           | Magnetic incremental strip for MS01-1/D, per cm | <a href="#">0150-1963</a> |
| <b>KS025-D15/D-Encoder</b> | Encoder Cable (Length in m)                     | <a href="#">0150-3168</a> |

FIND MORE PRODUCT DETAILS IN THE CHAPTER "ACCESSORIES".



| Item                        | Description  | Item-No.                  |
|-----------------------------|--|---------------------------|
| <b>MS01-1/D-SSI</b>         | Linear Encoder 1µm, A/B (for absolute strip)                           | <a href="#">0150-2095</a> |
| <b>MB01-1000-ABS</b>        | Magnetic absolute strip for MS01-1/D-SSI (per cm)                      | <a href="#">0150-2096</a> |
| <b>EC01-ABS/ENC-12-S</b>    | MS01-1/D-SSI Encoder connector straight                                | <a href="#">0150-3616</a> |
| <b>KSS01-12-D15/ABS-ENC</b> | Special cable for MS01-1/D-SSI on C1100/C1200/C1400/E1200/E1400 Drives | <a href="#">0150-3652</a> |

FIND MORE PRODUCT DETAILS IN THE CHAPTER "ACCESSORIES".

Area with horizontal dotted lines for notes.