

Installation Guide Linear Motors

ENG

P10-70 / P10-70-Dxx



Content

1	General information	4
1.1	Introduction	4
1.2	Explanation of symbols	4
1.3	Qualified personnel	4
1.4	Liability	4
1.5	Copyright	4
2	Safety instructions	5
3	Installation instructions	7
3.1	Operating conditions	7
3.2	Instructions for installing the linear motor	7
3.3	Mounting the stator	8
3.4	Mounting the payload to the slider	8
3.5	"Moving slider" installation	10
3.6	"Moving stator" installation	10
3.6.1	Assembling instruction	11
3.7	Minimum distance from slider	12
3.7.1	Minimum distance from slider to slider	12
3.7.2	Minimum distance from slider to metallic parts	13
4	Stroke Range	13
5	Fluid cooling	14
5.1	Design of water cooling	14
5.1.1	Determination of the max. possible amount of cont. power dissipation P_{v_Max}	14
5.1.2	Determination of water flow Q	15
5.1.3	Determination of water pressure Δp	15
5.2	Corrosion Protection	16
6	Electrical Connection	16
6.1	Technical Data of Motor Cables	16
6.2	Stator connector assignment	17
6.2.1	Power Connector	17
6.2.2	Encoder Connector	18
6.3	Attaching the cable shielding	20
6.4	Rotatability of motor connectors	20
7	Accessories	22
7.1	Motor Cables for use with LinMot Drives	22
7.2	Motor Cables for use with third-party Drives	23
7.3	Wiper with exchangeable end pieces	25
7.4	Wiper with lubricant depot	26
7.5	Bearing kit with exchangeable end pieces	27
7.5.1	Overview	27
7.5.2	Mounting	28
7.6	Bearing kit with lubricant depot	29
7.6.1	Overview	29

7.6.2	Mounting	30
7.7	Mounting flanges	31
7.8	Fan kits for flanges	33
7.9	Fluid cooling flanges	34
7.10	Slider mounting kits	36
7.10.1	Fixed bearing	36
7.10.2	Floating bearing	37
7.10.3	Complete mounting kit	37
8	Maintenance and test instructions	38
8.1	Stator checking	38
8.2	Maintenance of linear motors	39
8.2.1	Mounting	39
8.2.2	Inspection	39
8.2.3	Cleaning	40
8.2.4	Cleaning agent / Lubricant	40
9	Storage, transport, installation altitude	40
10	Dimensions	41
10.1	Stator	41
10.1.1	PS10-70x80	41
10.1.2	PS10-70x160	41
10.1.3	PS10-70x240	41
10.1.4	PS10-70x320	41
10.1.5	PS10-70x400	42
10.2	Slider	42
11	International Certificates	43
12	UL Certificate	45
13	EU Declaration of Conformity CE-Marking	49
14	UK Declaration of Conformity UKCA-Marking	50

1 General information

1.1 Introduction

This manual includes instructions for the assembly, installation, maintenance, transport, and storage of linear motors. The document is intended for electricians, mechanics, service technicians, and warehouse staff. Be sure to observe the general safety instructions as well as those in each chapter at all times. Keep this manual accessible to the assigned staff.

1.2 Explanation of symbols



Triangular warning symbols warn against a danger.



Round command symbols tell what to do.

1.3 Qualified personnel

All work such as transport, installation, commissioning and service is only allowed to be carried out by qualified personnel. Qualified personnel in the sense of the safety instructions in this documentation are persons who are familiar with the transport, installation, assembly, commissioning and operation of the product and who have the appropriate qualifications.

This manual must be read carefully before transport, installation, commissioning, service and all safety-related information must be adhered to.

1.4 Liability

NTI AG (as manufacturer of LinMot linear motors and MagSpring products) excludes all liability for damages and expenses caused by incorrect use of the products. This also applies to false applications, which are caused by NTI AG's own data and notes, for example in the course of sales, support or application activities. It is the sole responsibility of the user to check the information and information provided by NTI AG regarding their safety-relevant correctness. In addition, the entire responsibility for safety-related product functionality lies exclusively with the user. Product warranties are void if products are used with stators, sliders, servo drives or cables not manufactured by NTI AG unless such use was specifically approved by NTI AG. NTI AG's warranty is limited to repair or replacement as stated in our standard warranty policy as described in our "terms and conditions" previously supplied to the purchaser of our equipment (please request copy of same if not otherwise available). Further reference is made to our general terms and conditions.

1.5 Copyright

This work is protected by copyright.

Under the copyright laws, this publication may not be reproduced or transmitted in any form, electronic or mechanical, including photocopying, recording, microfilm, storing in an information retrieval system, not even for training purposes, or translating, in whole or in part, without the prior written consent of NTI AG.

LinMot® is a registered trademark of NTI AG.

2 Safety instructions



Contusions

Sliders contain neodymium magnets and have a strong attractive force. Careless handling could cause fingers or skin to become pinched between two sliders. This may lead to contusions, bruises, and bone fractures. When handling sliders, wear thick protective gloves and keep a minimum distance between sliders. Refer to the "Minimum distance from slider" section for minimum distance.

To reduce the risk of injury, never more than one slider should be held or transported by the same person without packaging.



Pacemaker / Implanted heart defibrillator

Sliders could affect the functioning of pacemakers and implanted heart defibrillators. For the duration of a strong approach to a magnetic field, these devices switch into test mode and will not function properly.

- If you wear one of those devices keep the following minimum distances between the pacemaker / defibrillator and slider:
 - Min. 250 mm (10") for slider Ø 27 mm and 28 mm (PL01-27 / 28 / PL1028)
 - Min. 150 mm (6") for slider Ø 19 mm and 20 mm (PL01-19 / 20)
 - Min. 100 mm (4") for slider Ø 12 mm (PL01-12)
- Inform others who wear these devices to comply with these minimum distances!



Caution - Risk of Electric Shock !

Before working, make sure that there are no high voltages.



Fast-moving machine parts

The sliders of LinMot linear motors are fast-moving machine parts. All necessary precautions must be taken to prevent access during operation (provide covers, guards, etc.).



Automatic restart

The motors can start automatically under certain circumstances! If necessary, a corresponding warning symbol must be provided and protection against entering the hazardous area or a suitable safe electronic disconnection must be provided!



Risk of injury due to a defect or fault

For areas where a defect or fault can result in substantial property damage or even serious personal injury, additional external precautions must be taken or devices must be installed to ensure safe operation even if a defect or fault occurs (eg. suitable safe electronic disconnection, mechanical interlocks, barriers, etc.).



Magnetic field

Magnets integrated in the sliders produce a strong magnetic field. They could damage TVs, laptops, computer hard drives, credit and ATM cards, data storage media, mechanical watches, hearing aids, and speakers.

- Keep magnets away from devices and objects that could be damaged by strong magnetic fields.
- For the above mentioned objects, keep a minimum distance as described in the "Pacemaker / implanted defibrillator" section.
- For non-anti-magnetic watches, keep the double minimum distance.

**Combustibility**

When machining magnets, the drilling dust could easily ignite. Machining the sliders and the magnets they contain is not permitted.

**Burn hazard**

The sliders of LinMot motors can reach temperatures of 80 °C, which may cause burns upon contact.

**Grounding**

All metal parts that are exposed to contact during any user operation or servicing and likely to become energized shall be reliably connected to the means for grounding.

**Mechanical handling**

Neodymium magnets are brittle and heat-sensitive. Machining the sliders and the magnets they contain is not permitted.

- Colliding magnets could crack. Sharp splinters could be catapulted for several meters and cause eye injury.
- By machining the sliders, heat would result which demagnetises the magnets.

**Slider**

Linear motor sliders consist of a high-precision, thin-walled stainless steel tube in which the neodymium magnets are housed. The LinMot sliders should be handled with care. Avoid contact with other sliders or iron parts as this can damage the magnets and the slider surface. Do not grip the sliders with pliers, as this can also damage the surface. Do not use sliders which are already damaged on the surface (scratches, deformation, etc.). This can cause further damage to the stator.

**Effects on people**

According to the current level of knowledge, magnetic fields of permanent magnets do not have a measurable positive or negative effect on people. It is unlikely that permanent magnets constitute a health risk, but it cannot be ruled out entirely.

- For your own safety, avoid constant contact with magnets.
- Store large magnets at least one meter away from your body.

**Temperature resistance**

Keep slider away from unshielded flame or heat. Temperature above 120°C will cause demagnetization.

3 Installation instructions

3.1 Operating conditions



Maximum ambient temperature limits:

- 10 °C...80 °C

Internal temperature sensor error occurs at:

- 90 °C

3.2 Instructions for installing the linear motor



Please attend to the safety instructions in chapter 2 during the assembling!



For maintenance purposes, please observe the installation instructions in chapter 7.

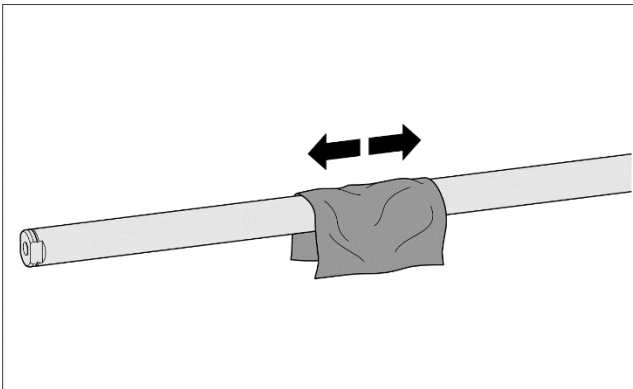

1. Clean the slider with a paper towel.

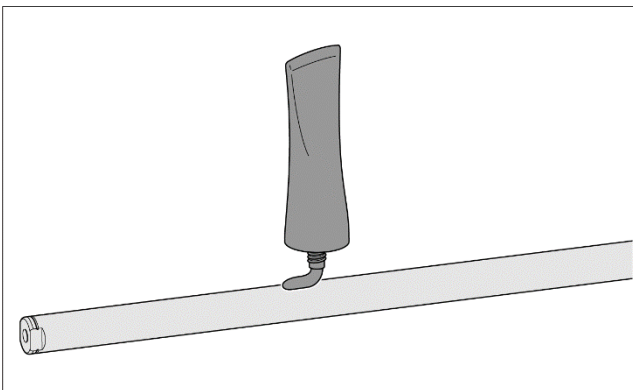

2. Lubrication of the slider

Sliders with a length ≤ 500 mm are inserted without lubrication.

Sliders with a length > 500 mm are lubricated with a grease amount of 4 g (0.14 oz) per meter, which is about $\frac{1}{2}$ of a hazel-nut.

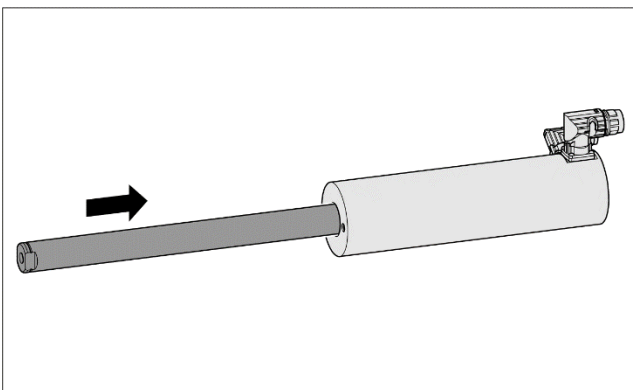

3. Insert the slider in the defined direction (see Assembly step 4.).

Attention! The slider is magnetically attracted.

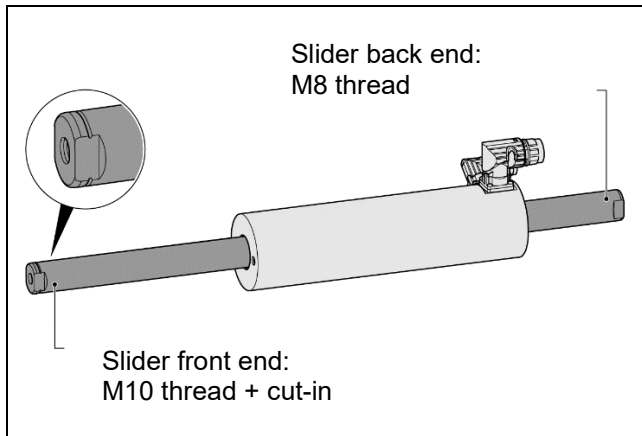

4. **Checking the installed direction of slider**
After the installation, the front end of the slider with M 10 thread and cut-in is located at the opposite side of the stator from the cable exit.

Attention! Slider back end should not be used for load mounting!

3.3 Mounting the stator

The stator is mounted by clamping. The LinMot flange (see the section 6 Accessories) or a similar flange can be used for this purpose. Most important is a broad clamping surface in order to provide good heat dissipation. Additionally, the cooling can be increased by a fan or liquid (water cooling), so that the continuous power is significantly improved.



The flange clamp must not deform the stator.
Do not exceed max. torque of **16 Nm**.



Incorrect mounting

Small contact area prevents cooling of the linear motor.

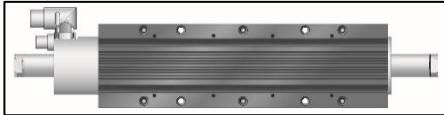

Correct mounting

Better heat dissipation with the LinMot flange.

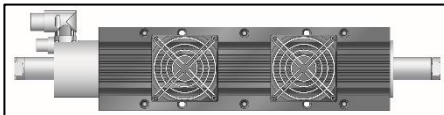

Correct mounting

Forced air cooling with LinMot fan to increase the continuous force.

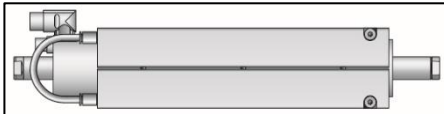

Correct mounting

Forced cooling with fluid cooling flange to increase the continuous force. More details in chapter 4 Fluid cooling.

3.4 Mounting the payload to the slider

The load is mounted as a fixed bearing using spherical washers and conical seats (see the section 6).



- To avoid shear force on slider and wear on stator, the payload has to be beared by a linear guide.
- Slider back end (M8 internal thread) should not be used for load mounting.

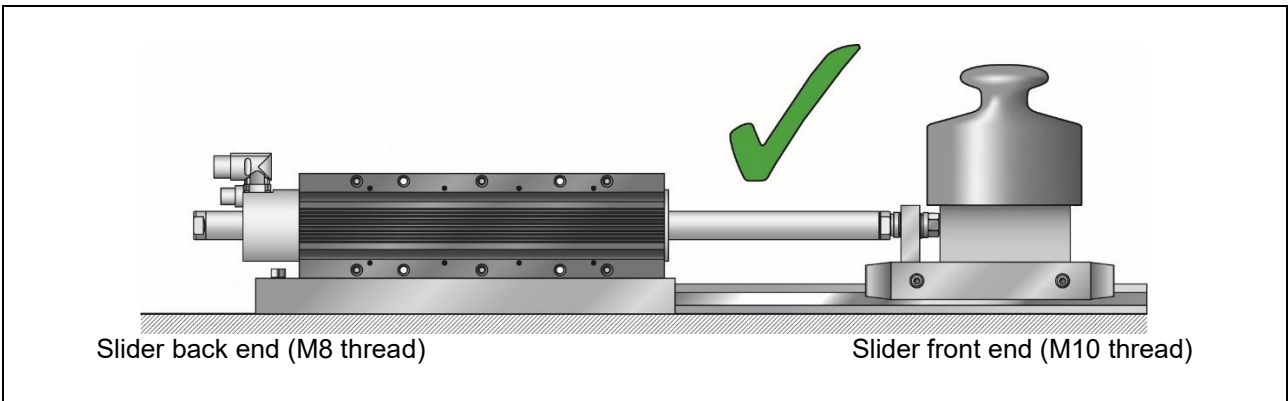
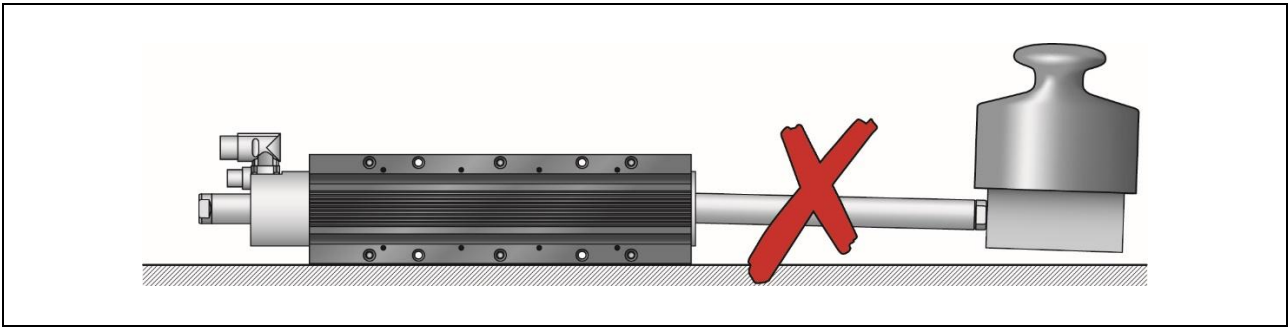

When attaching the load, the wrench for tightening the load must be used only on the load-facing side of the slider. Avoid torsional stress on slider (note the following figures).

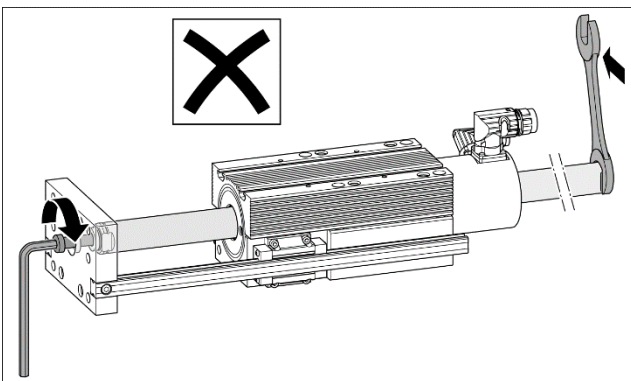

Incorrect mounting
Torsional stress on slider!

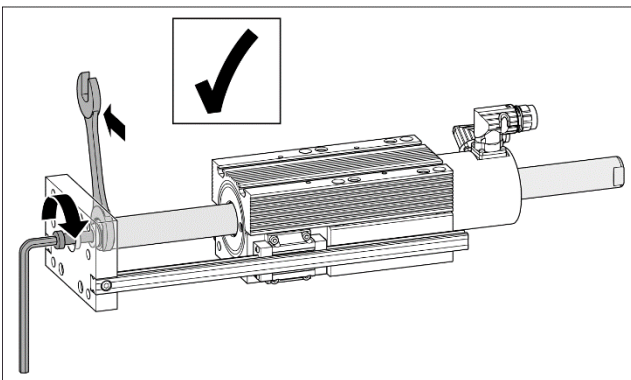

Correct mounting

Slider	Thread	Max. torque for screw (Dry)
28 mm	M 8 (Slider back end)	22.5 Nm
	M 10 (Slider front end)	42 Nm

3.5 "Moving slider" installation

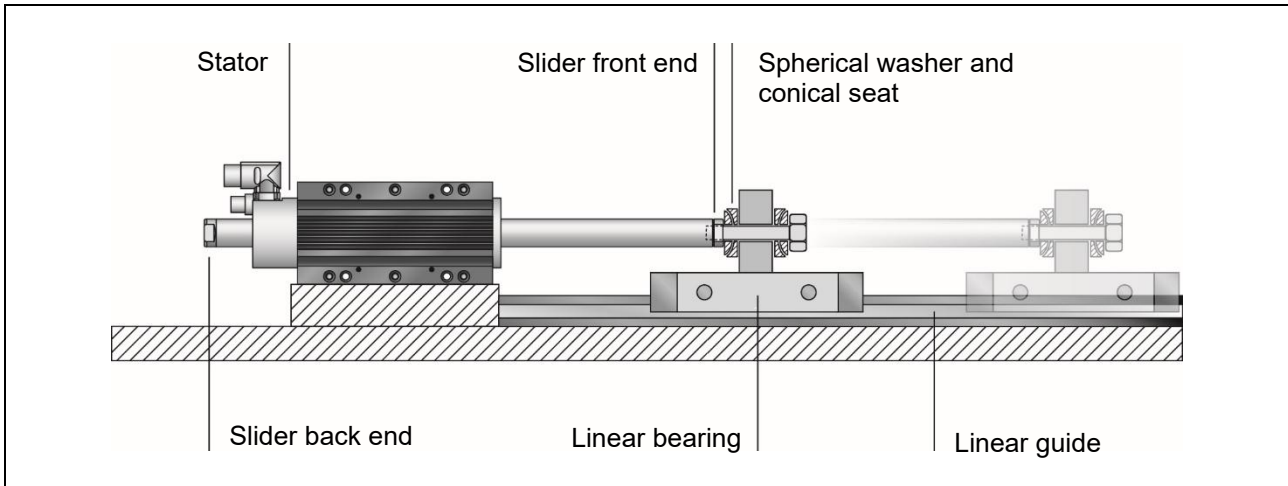

In a "moving slider" installation, the stator is fixed and the slider is the moving part. The load, borne by a linear guide, is attached directly to the end of the slider. In order to compensate for misalignment, spherical axial bearings consisting of spherical washers and conical seats (see the section Slider mounting kits) are used to connect to the load. The mounting kit of slider and an oversized hole for the screw make it possible to adjust a radial and angle offset.

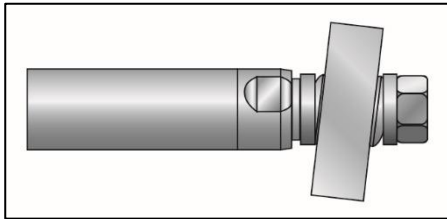

Mounted payload with radial and angle offset.

3.6 "Moving stator" installation

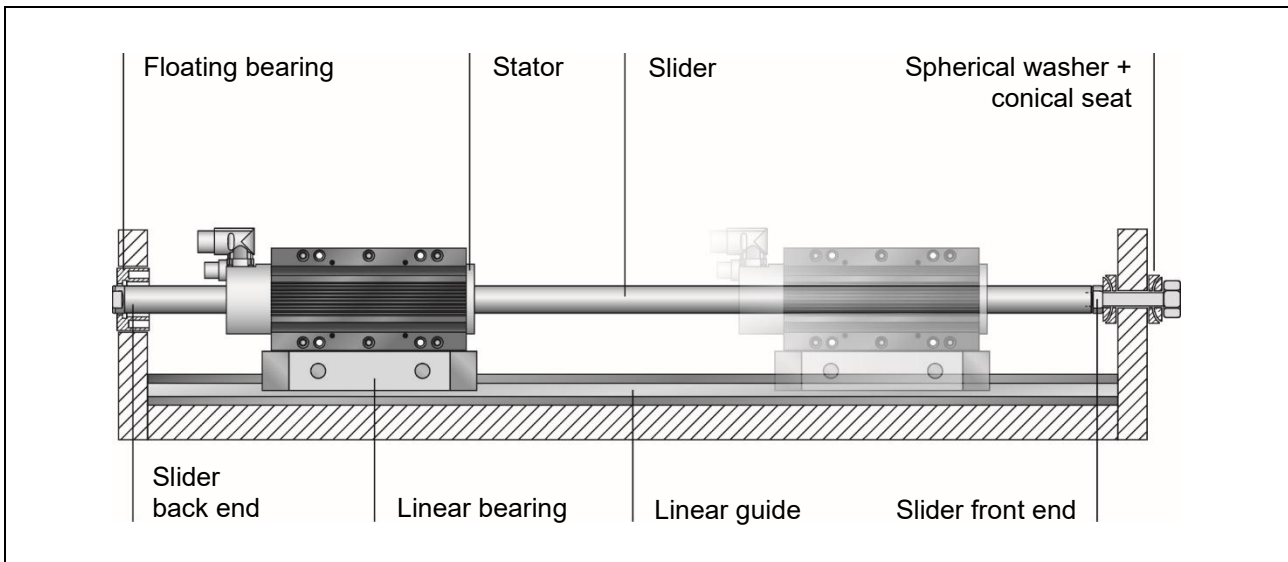

In "moving stator" applications, the slider is fixed and the stator is the moving part. The load is attached to the stator, which is mounted on a linear guide. In order to avoid an overconstrained bearing mount and compensate for alignment errors, the slider may be mounted on one end in a fixed bearing with a spherical axial bearing. On the opposite end, the slider is mounted in a floating bearing. Mounting kits are available for mounting the slider (see the section Slider mounting kits).

3.6.1 Assembling instruction



Please attend to the safety instructions in chapter 2 during the assembling!



If moving stator application is used, the minimum bending radius of the motor cable should be adhered to. See chapter Cable, section Technical Data.

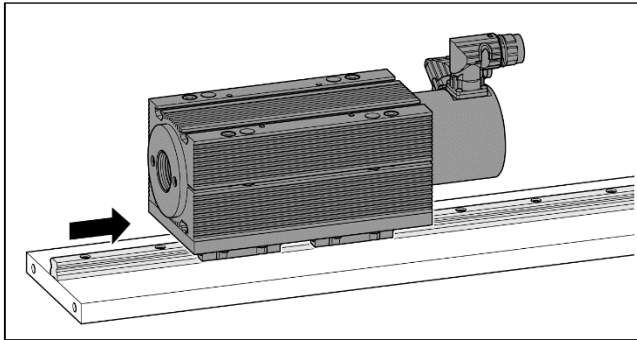

1. Mount stator to its support bearing.

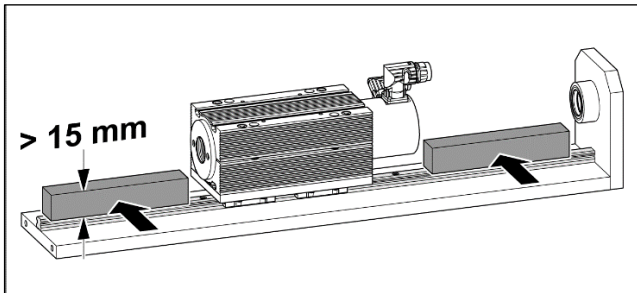

2. Placing a spacer

Put a spacer (wood, plastic, aluminium with thickness 15 mm) between slider and linear guide. The spacer prevents injuries to the hands and damage to the slider surface!

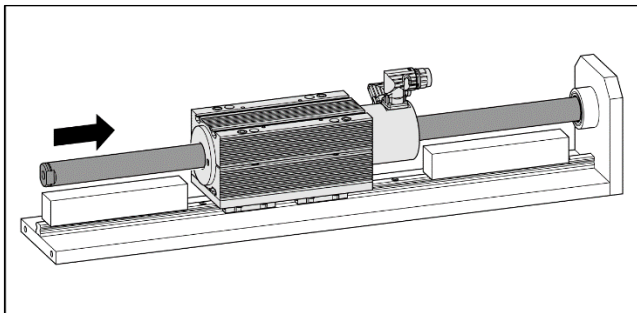

3. Insert slider into stator.

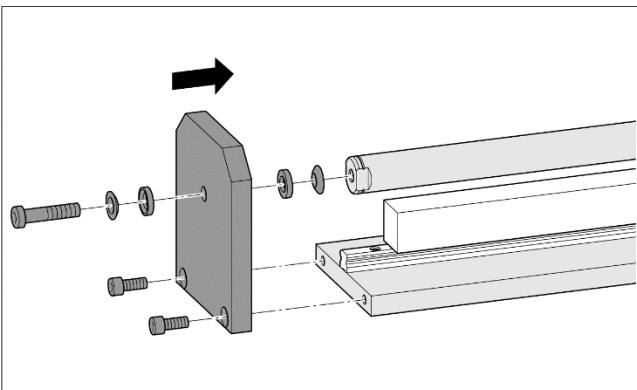

4. Installing the slider using the fixed bearing

The fixed bearing is screwed to the front end of the slider.

Important! Do not tighten the screw yet!

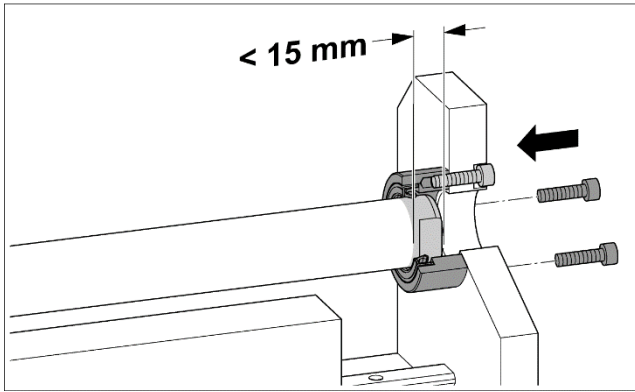

5. Mount floating bearing

Important!

Do not tighten the screw!
The slider is allowed to extend into the floating bearing no more than 15 mm!

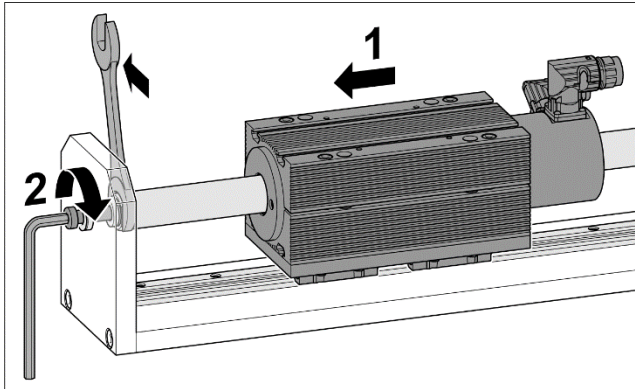

6. Move stator (back end) to the fixed end of slider, center slider in stator and tighten the screw.

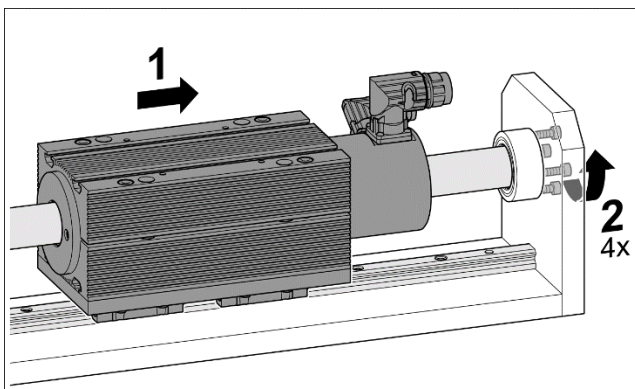

7. Move stator (front side) to the floating bearing and tighten screws.



After the installation of the slider a safety label must be placed close to the slider.

3.7 Minimum distance from slider

3.7.1 Minimum distance from slider to slider

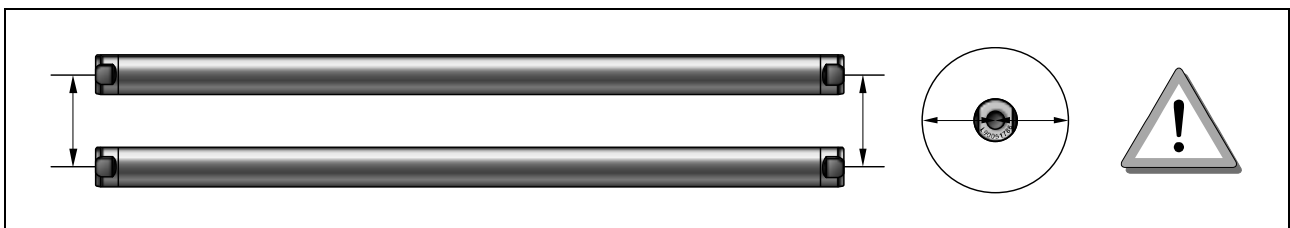

The sliders are made of neodymium magnets and have a strong magnetic attraction. It must be kept a minimum distance between the sliders. This minimized the risk of bruising and secondly, the sliders do not influence each other through their magnetic fields.

Type of slider	PL01	PL01-20 / PL01-19	PL01-28 / PL01-27	PL10-28
PL01-12	30 mm (1.18 in)			
PL01-20 / PL01-19		50 mm (1.97 in)		
PL01-28 / PL01-27			80 mm (3.15 in)	
PL10-28				70 mm (2.76 in)

The data are measured from slider center to slider center.

3.7.2 Minimum distance from slider to metallic parts

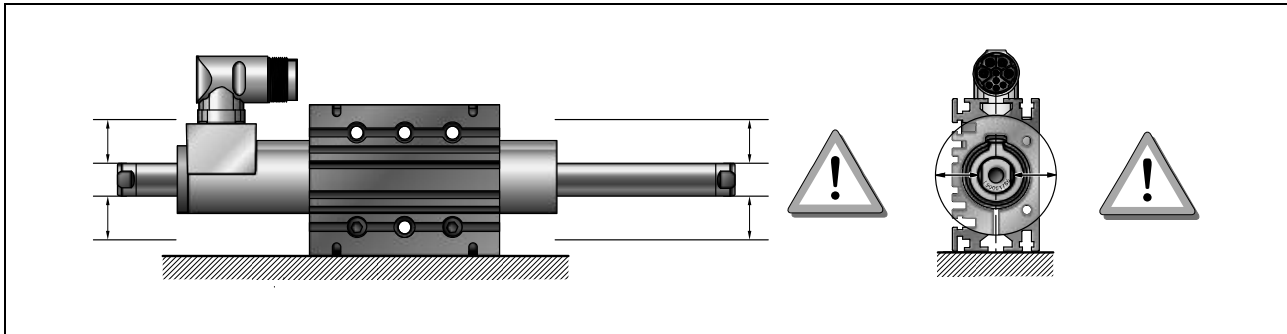

When installing linear motors in modules with metal parts near the slider, undesired forces can arise due to magnetic attraction or eddy currents. These generally manifest as erratic and jerky positioning, or reduced dynamics of the linear motor. In order to avoid this, minimum distances between the slider and any metal parts are to be observed whenever metal materials are used nearby.

Linear Motor	Minimum distance from slider surface to ferromagnetic parts (iron, steel, etc.)	Minimum distance from slider surface to non-ferromagnetic metallic parts (aluminum, bronze, stainless steel, etc.)
P10-70x...	20 mm	10 mm

4 Stroke Range

The stroke range where a constant maximum force is generated is the range where the active stator length is completely filled with drive magnets. According to the geometry, this results in a fixed start position (15 mm) and end position (25 mm) of the stroke. See the following figure.

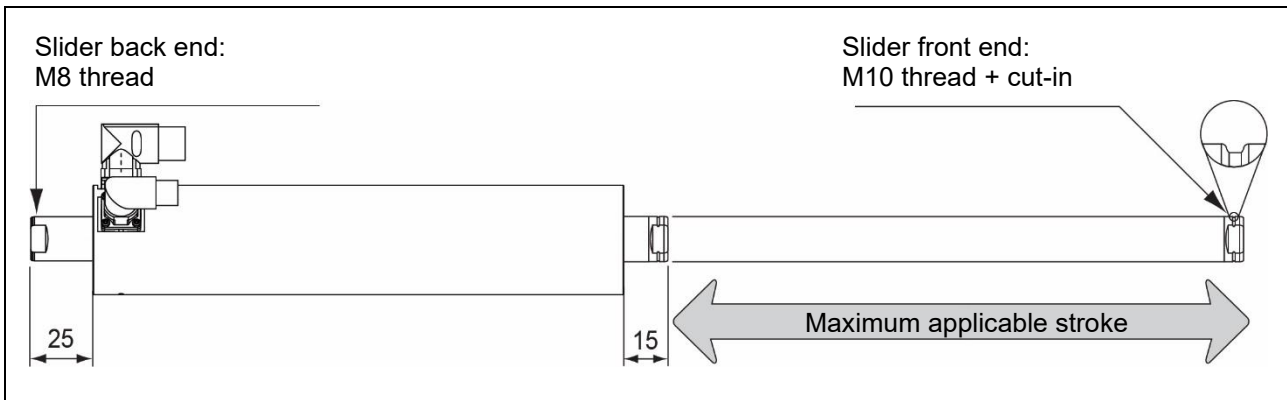

5 Fluid cooling

The heat produced by the motor is dissipated by the liquid cooling. If the motor is operated with a liquid-cooling, the continuous force value increases many times in comparison with the self-cooling.

5.1 Design of water cooling

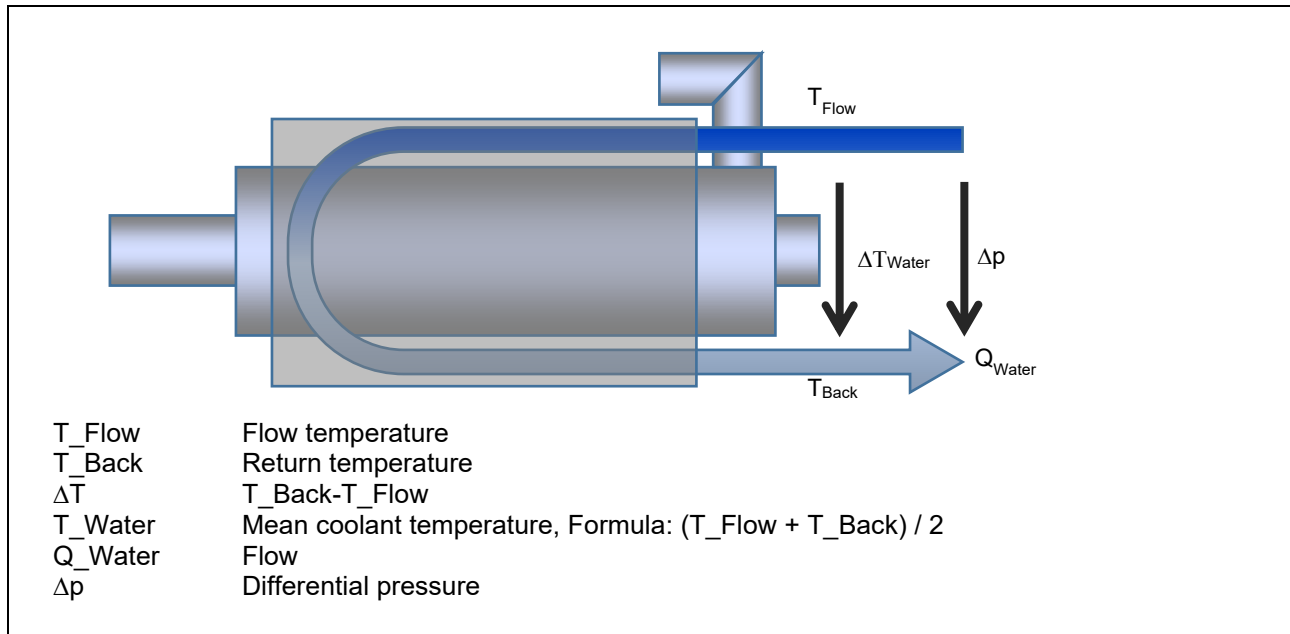

With the water cooling, the coolant is passed through the cooling circuit of the motor flange.

Starting from the adjusted mean coolant temperature T_{Water} all other parameters of the cooling circuit may be dimensioned based on the diagrams referred to:

- $T_{Water} \rightarrow P_{v_Max} \rightarrow Q_{Water} \rightarrow \Delta p$

The design is illustrated by an example in the following.

5.1.1 Determination of the max. possible amount of cont. power dissipation P_{v_Max}

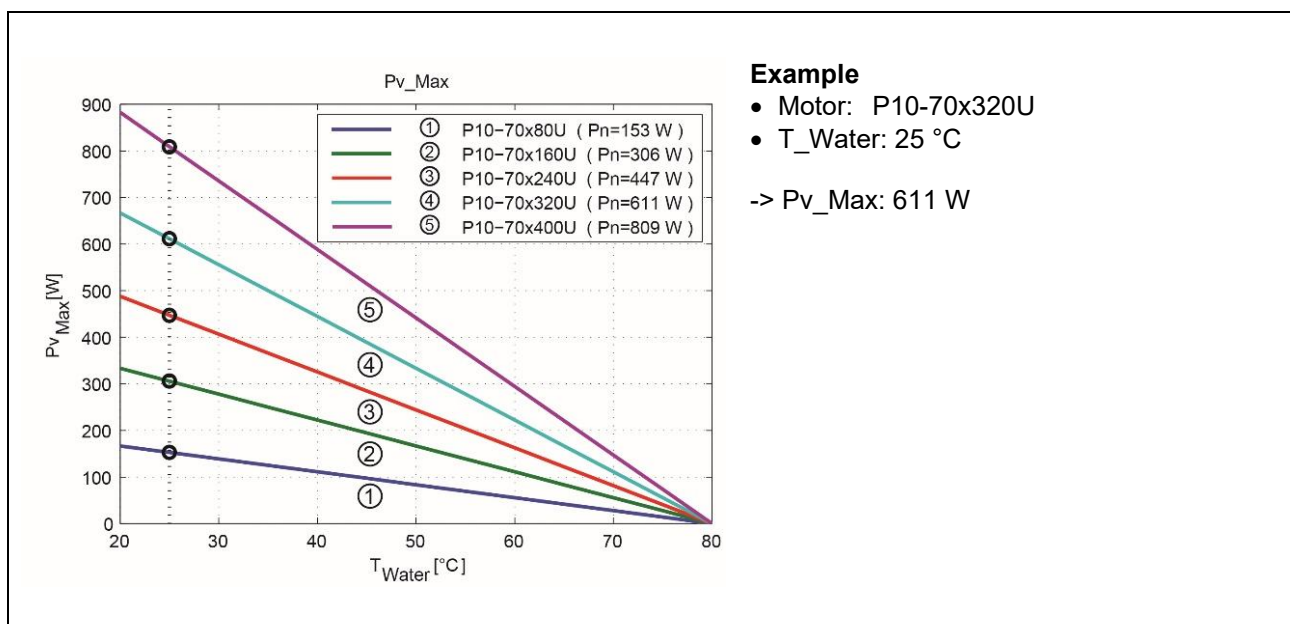



- If the temperature of the cooling liquid is chosen to be lower than the ambient temperature, there is a risk of condensation.
- When used and stored in a frost-prone area, corrosion protection (e.g. Clariant) has to be added.

5.1.2 Determination of water flow Q

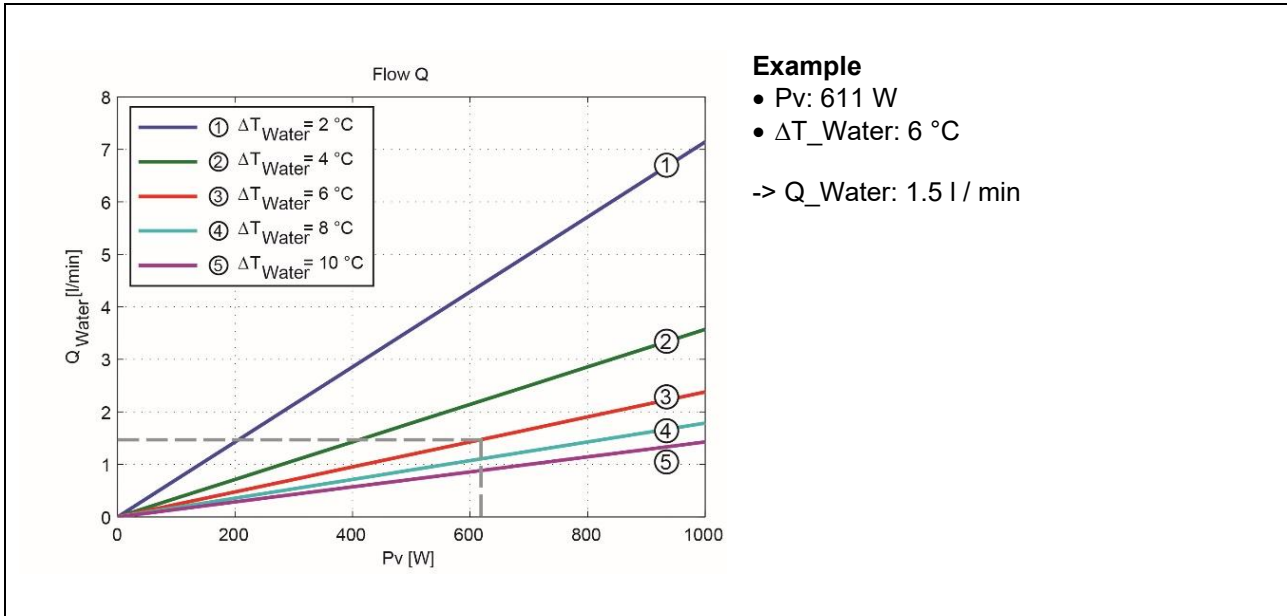

To achieve a very regular cooling of the motor, the max. difference between flow and return temperature should not exceed 10 °C.

5.1.3 Determination of water pressure Δp

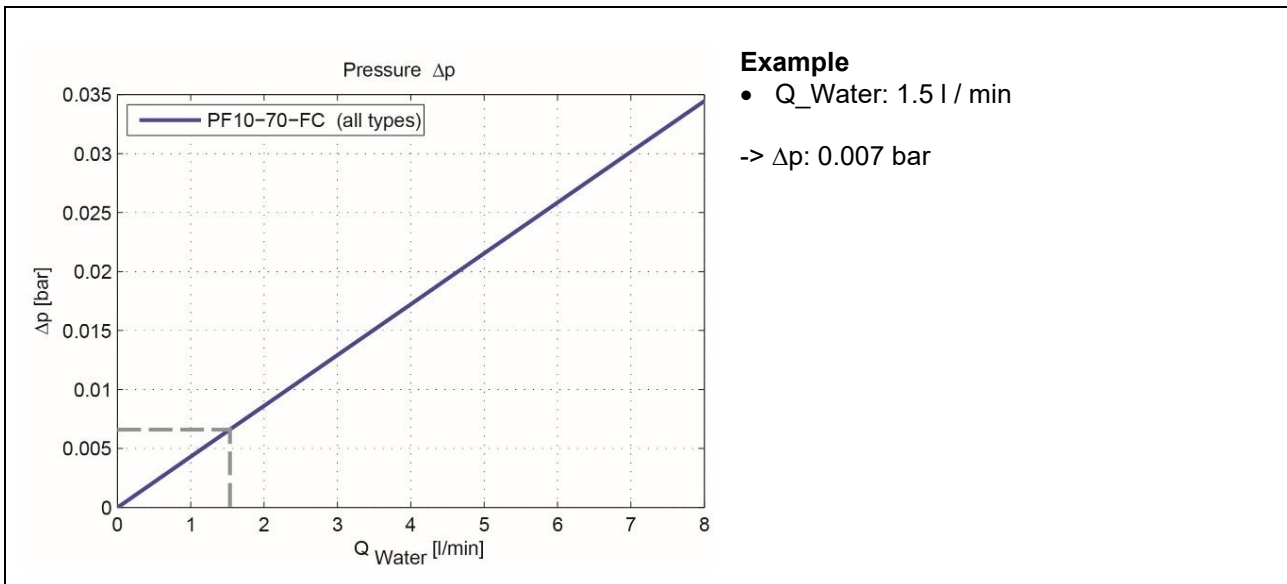

The required water pressure to inject the required water flow depends on the hydraulic resistance of the cooling circuit.

5.2 Corrosion Protection

It is advised to add a corrosion protection into the cooling medium (water). A suitable agent can be, for example, Protectogen C Aqua by Clariant. Information of the mixing ratio between the cooling medium and the corrosion protection agent can be taken from the manufacturer's instructions.



- Mixing of various corrosion protection agents is to be avoided.
- Corrosion protection products must be matched to the materials of the cooling circuit (see table of materials in the cooling circuit).

Component	Material
Flange	Aluminium
Pipe	Polyurethane
Fittings	Brass nickel plated

6 Electrical Connection



Do not connect or disconnect motor when there is power on the servo drive. Use only original LinMot cable. Cables from other sources must be checked precisely before commissioning. Incorrect connections can destroy the drive and stator.

6.1 Technical Data of Motor Cables

For the linear motors of the P10-70 series, different cable types are used for the power and signal supply, depending on the use of the drive type (LinMot or third-party manufacturer). All cables are high-flex cables (suitable for trailing chains) and are used for both fixed and moving applications.

Type	Power cable		Encoder cable	
	KPS15-04	KPS15-04/04	KSS05-02/08	KSS05-02/13
Application for	LinMot drives + Third-party drives	Third-party drives	LinMot drives	Third-party drives
Minimum bending radius for fixed installation	50 mm (2 in)	60 mm (2.36 in)	50 mm (2 in)	45 mm (1.75 in)
Minimum bending radius when moving	100 mm (4 in) No torsion	120 mm (4.72 in) No torsion	100 mm (4 in) No torsion	90 mm (3.54 in) No torsion
Max. Cable length	30 m (can be limited by the servo drive)			
Approval	UL / CSA 1000V	UL / CSA 1000V / 300V	UL / CSA 300V	UL / CSA 30V
Material	Wire isolation: TPE Jacket: PUR	Wire isolation: TPE Jacket: PUR	Wire isolation: TPE Jacket: PUR	Wire isolation: PE Jacket: PUR
Oil resistance	sehr gut	sehr gut	sehr gut	sehr gut
Chemical resistance (to acids, alkalis, solvents, hydraulic fluid)	good	good	good	good
Outdoor durability	very good	very good	very good	very good
Flammability	flame retardant	flame retardant	flame retardant	flame retardant

6.2 Stator connector assignment



Do not connect or disconnect motor when there is power on the servo drive.
Use only original LinMot cable. Cables from other sources must be checked precisely before commissioning.
Incorrect connections can destroy the drive and stator.

6.2.1 Power Connector

Shielded motor cable $d = 1.5 \text{ mm}^2$

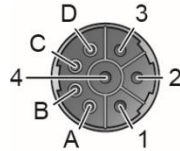

Pin	P10-70	P10-70-D08	P10-70-S03/1	P10-70-S05	P10-70-D26	Wire Color Motor Cable
1	Phase U					red
2	PE					yellow-green
3	Phase W					black
4	Phase V					blue
A ¹⁾	n.c.	KTY84/130+			Do not connect	purple
B ¹⁾	n.c.	KTY84/130-			Do not connect	grey
C	n.c.					yellow
D	n.c.					brown

Pin	P10-70-D05	P10-70-D25	P10-70-D25S	Wire Color Motor Cable
1	Phase U			red
2	PE			yellow-green
3	Phase W			black
4	Phase V			blue
A ¹⁾	PTC+			purple
B ¹⁾	PTC-			grey
C	n.c.			yellow
D	n.c.			brown

Pin	P10-70-D04	P10-70-D24	P10-70-D24S	P10-70-D34	P10-70-S03/2	Wire Color Motor Cable
1	Phase U					red
2	PE					yellow-green
3	Phase W					black
4	Phase V					blue
A ¹⁾	Pt1000+					purple
B ¹⁾	Pt1000-					grey
C	n.c.					yellow
D	n.c.					brown

¹⁾ The temperature evaluation circuit must have the same galvanic reference potential as the encoder circuit (supply). It should therefore be connected to the supply GND. For correct evaluation, the connection potentials of the emulated temperature sensor must be in the range of the supply potentials. Valid temperature values can only be measured 50ms after the encoder supply is applied. In currentless state a resistance of 200kOhm is measured between pin A and B. The maximum voltage between pin A and B must not exceed 16VDC. The maximum current is 15mA.

6.2.2 Encoder Connector

Shielded twisted pair
Encoder Cable d = 0.5 mm² / 0.25 mm²

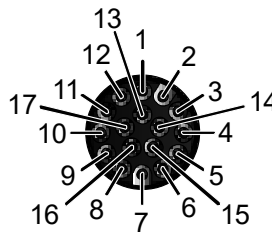

Pin	P10-70	Wire Color Motor Cable
1	+5VDC ¹⁾	red
2	GND	black
3	Sense +5V ¹⁾	white
4	Sense GND ¹⁾	brown
5	Motor Link C +	pink
6	Motor Link C -	grey
7	Sin +	yellow
8	Sin -	orange
9	Cos +	green
10	Cos -	blue
11 bis 17	n. c.	-

¹⁾ The supply voltage at 5V sense supply is approx. 6V. Newer motors are provided with a modified power supply, that does not require sense lines any more. In that case, a supply voltage of 6...9V is permitted.

Pin	P10-70-D04	P10-70-D05	P10-70-D08	P10-70-S03/1 P10-70-S03/2 P10-70-S05	Wire Color Motor Cable
1	3...13 VDC				white
2	GND				brown
3	Vcc Sense (optional)				green
4	GND Sense (optional)				yellow
5	Do not connect				-
6	Do not connect				-
7	Sin +				grey
8	Sin -				pink
9	Cos +				blue
10	Cos -				red
11	Ref +				black
12	Ref -				violett
13	Hall U				grey-red
14	Hall V				red-blue
15	Hall W				white-green
16 ²⁾	Pt1000+	PTC+	KTY 84/130+	Do not connect	yellow-brown
17 ²⁾	Pt1000-	PTC-	KTY 84/130-	Do not connect	white-yellow

²⁾ The temperature evaluation circuit must have the same galvanic reference potential as the encoder circuit (supply). It should therefore be connected to the supply GND. For correct evaluation, the connection potentials of the emulated temperature sensor must be in the range of the supply potentials. Valid temperature values can only be measured 50ms after the encoder supply is applied. In the currentless state, a resistance of 200kOhm is measured between pin 16 and 17 is measured. The maximum voltage between pin 16 and 17 must not exceed 16VDC. The maximum current is 15mA.

Pin	P10-70-D24 P10-70-D24S	P10-70-D25 P10-70-D25S	P10-70-D26	Wire Color Motor Cable
1	3...13 VDC			white
2	GND			brown
3	Vcc Sense (optional)			green
4	GND Sense (optional)			yellow
5	Do not connect			–
6	Do not connect			–
7	A			grey
8	/ A			pink
9	B			blue
10	/ B			red
11	Ref			black
12	/ Ref			violett
13	Hall U			grey-red
14	Hall V			red-blue
15	Hall W			white-green
16 ¹⁾	PTC+			yellow-brown
17 ¹⁾	PTC-		Do not connect	white-yellow

Pin	P10-70-D34	Aderfarbe Motorkabel
1	3...13 VDC	white
2	GND	brown
3	Vcc Sense (optional)	green
4	GND Sense (optional)	yellow
5	Do not connect	–
6	Do not connect	–
7	Slave out+	grey
8	Slave out-	pink
9	Do not connect	–
10	Do not connect	–
11	Master clock+	black
12	Master clock-	violett
13	Hall U	grey-red
14	Hall V	red-blue
15	Hall W	white-green
16 ¹⁾	Pt1000+	yellow-brown
17 ¹⁾	Pt1000-	white-yellow

¹⁾ The temperature evaluation circuit must have the same galvanic reference potential as the encoder circuit (supply). It should therefore be connected to the supply GND. For correct evaluation, the connection potentials of the emulated temperature sensor must be in the range of the supply potentials. Valid temperature values can only be measured 50ms after the encoder supply is applied. In the currentless state, a resistance of 200kOhm is measured between pin 16 and 17 is measured. The maximum voltage between pin 16 and 17 must not exceed 16VDC. The maximum current is 15mA.

6.3 Attaching the cable shielding

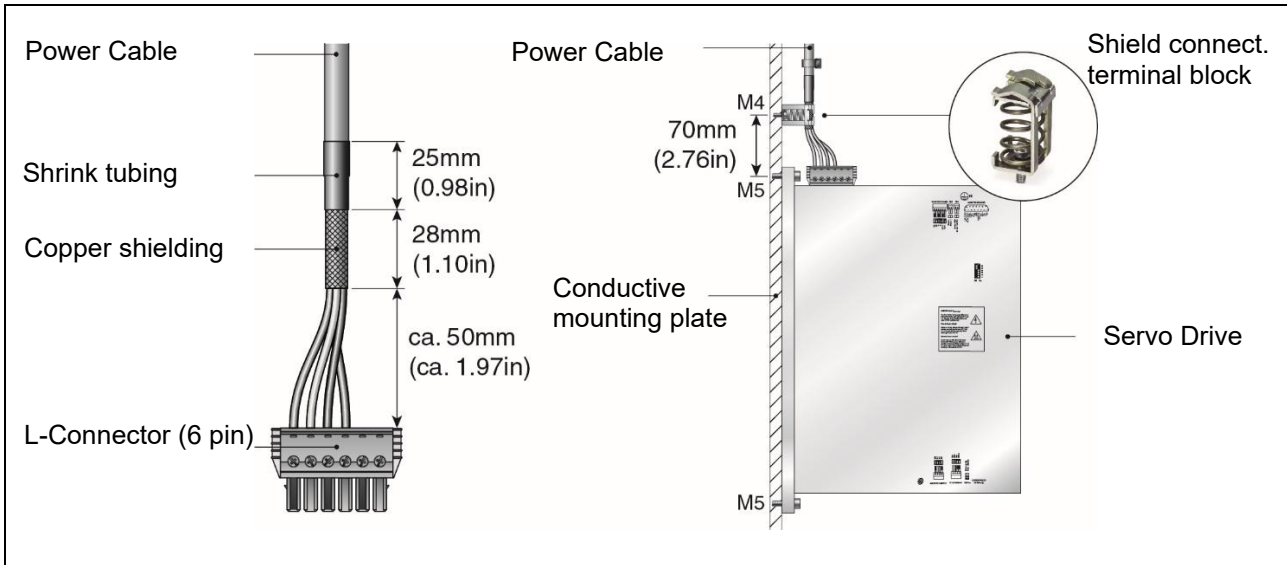

The power cable is supplied with a copper shielding (see illustration above). This prevents electrical and / or magnetic fields. The shielded part of the cable must be grounded via a connection to the back wall of the switchboard. The shielding has to be mounted holohedral to the connection part (see scheme above). The shield connection terminal block is offered as an accessory for power cables and must be ordered separately (Item-No. 0150-3631) However, the kind of attaching the cable shielding generally depends on the system of the switchboard manufacturer.

6.4 Rotatability of motor connectors

The power connector and signal connector can be rotated in both directions. (see illustration below).

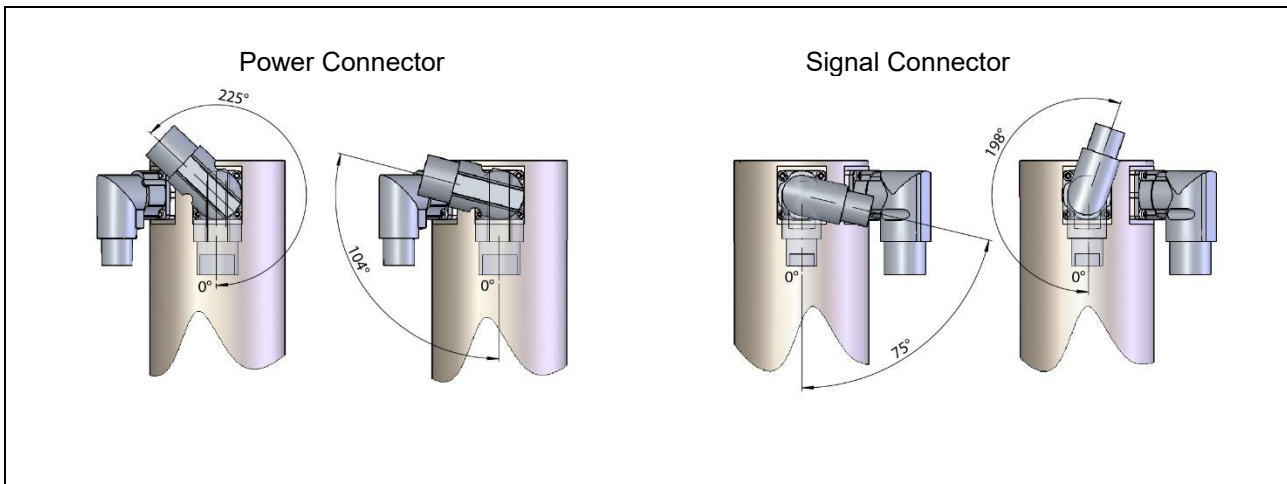

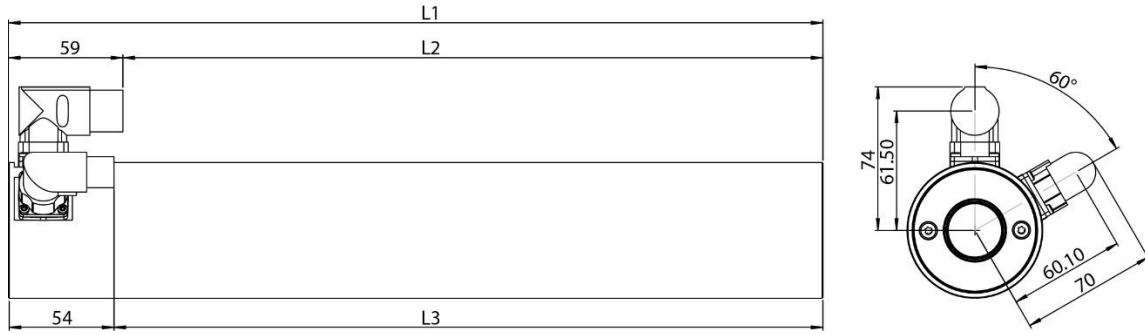

Stator	L1 [mm / in]	L2 [mm / in]	L3 [mm / in]
PS10-70x80	180 / 7.09	121 / 4.77	125.5 / 4.94
PS10-70x160	260 / 10.24	201 / 7.92	205.6 / 8.1
PS10-70x240	340 / 13.39	281 / 11.07	285.5 / 11.24
PS10-70x320	420 / 16.54	361 / 14.22	365.5 / 14.4
PS10-70x400	500 / 19.69	441 / 17.37	445.5 / 17.55

7 Accessories

7.1 Motor Cables for use with LinMot Drives

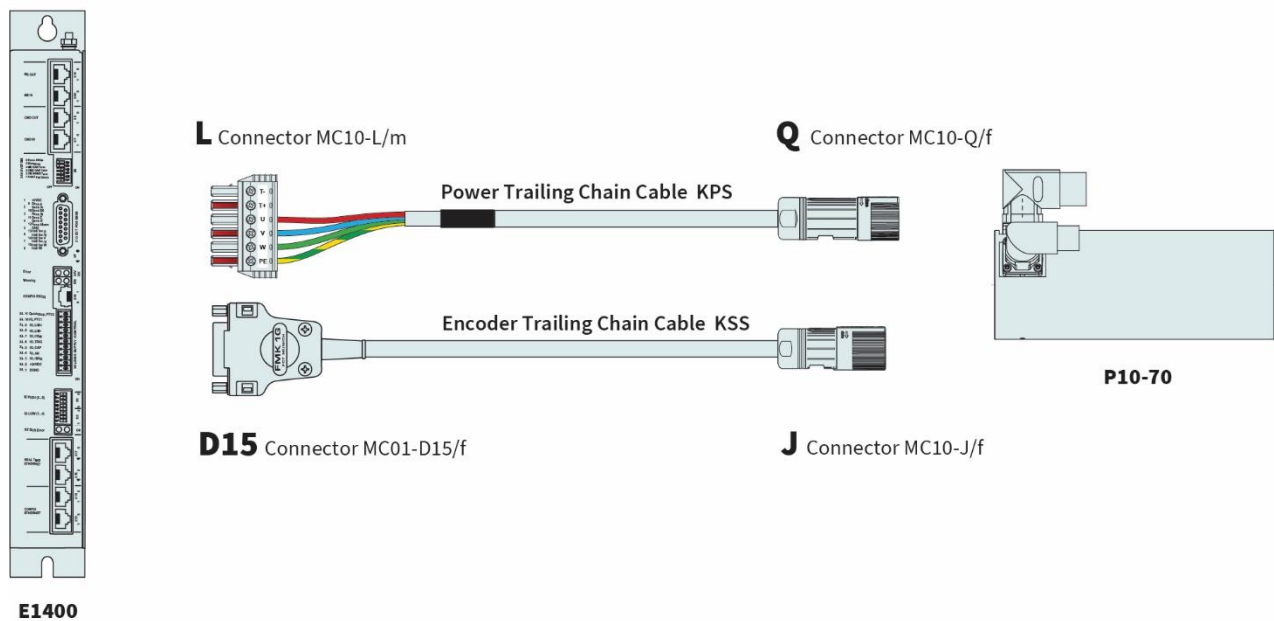
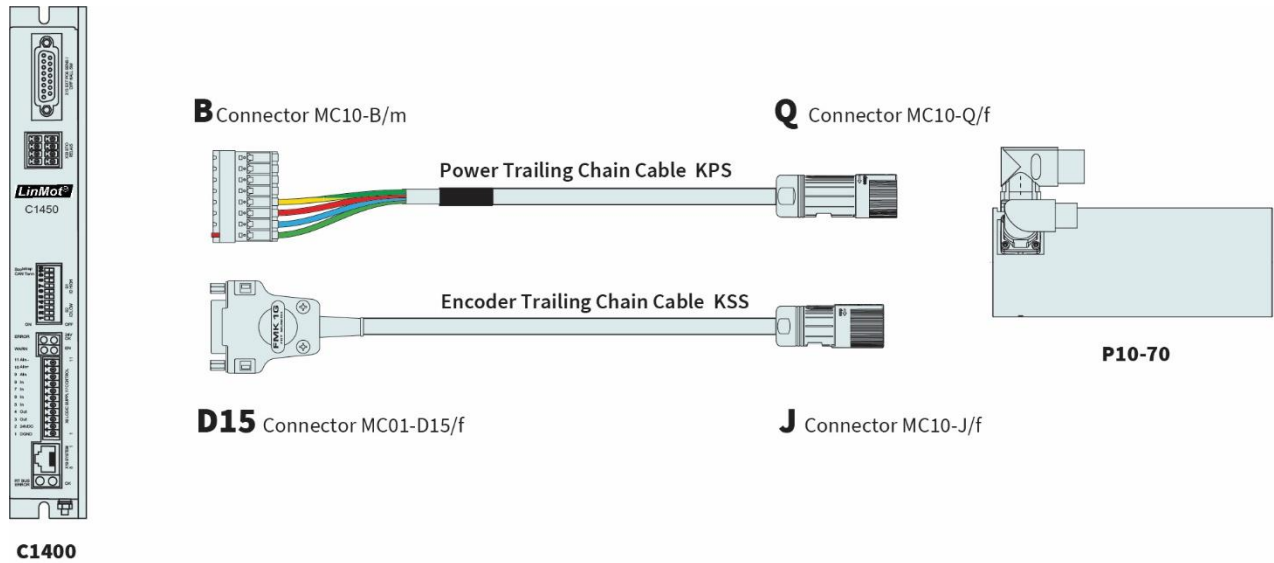

Power Cables

Item	Description	Item-No.
KPS15-04-L/Q-3	Power Trailing Chain Cable E1400/P10-70, 3 m	0150-2266
KPS15-04-L/Q-5	Power Trailing Chain Cable E1400/P10-70, 5 m	0150-2261
KPS15-04-L/Q-8	Power Trailing Chain Cable E1400/P10-70, 8 m	0150-2267
KPS15-04-L/Q-12	Power Trailing Chain Cable E1400/P10-70, 12 m	0150-2268
KPS15-04-L/Q-	Power Trailing Chain Cable L/Q-, Custom length	0150-3388
KPS15-04-B/Q-3	Power Trailing Chain Cable C1400/P10-70, 3 m	0150-3660
KPS15-04-B/Q-5	Power Trailing Chain Cable C1400/P10-70, 5 m	0150-3661
KPS15-04-B/Q-8	Power Trailing Chain Cable C1400/P10-70, 8 m	0150-3662
KPS15-04-B/Q-12	Power Trailing Chain Cable C1400/P10-70, 12 m	0150-3663
KPS15-04-B/Q-	Power Trailing Chain Cable B/Q-, Custom length	0150-3608

Encoder Cables

Item	Description	Item-No.
KSS05-02/08-D15/J-3	Encoder Trailing Chain Cable D15/J, 3 m	0150-2263
KSS05-02/08-D15/J-5	Encoder Trailing Chain Cable D15/J, 5 m	0150-2262
KSS05-02/08-D15/J-8	Encoder Trailing Chain Cable D15/J, 8 m	0150-2264
KSS05-02/08-D15/J-12	Encoder Trailing Chain Cable D15/J, 12 m	0150-2265
KSS05-02/08-D15(f)-45°/J-	Encoder Trailing Chain Cable D15/J-, Custom length	0150-3389

Extension Cables

Item	Description	Item-No.
KPS15-04-Q/Q-	Power Trailing Chain Cable Q/Q-, Custom length	0150-3414
KSS05-02/08-J/J-	Encoder Trailing Chain Cable J/J-, Custom length	0150-3415

Connectors

Item	Description	Item-No.
MC10-L/m	Connector Power E1400/X2	0150-3382
MC01-D15/f	Motor Connector D15 (f)	0150-3136
MC10-Q/f	Connector Power PS10-70	0150-2268
MC10-J/f	Connector Encoder PS10-70	0150-2269

7.2 Motor Cables for use with third-party Drives

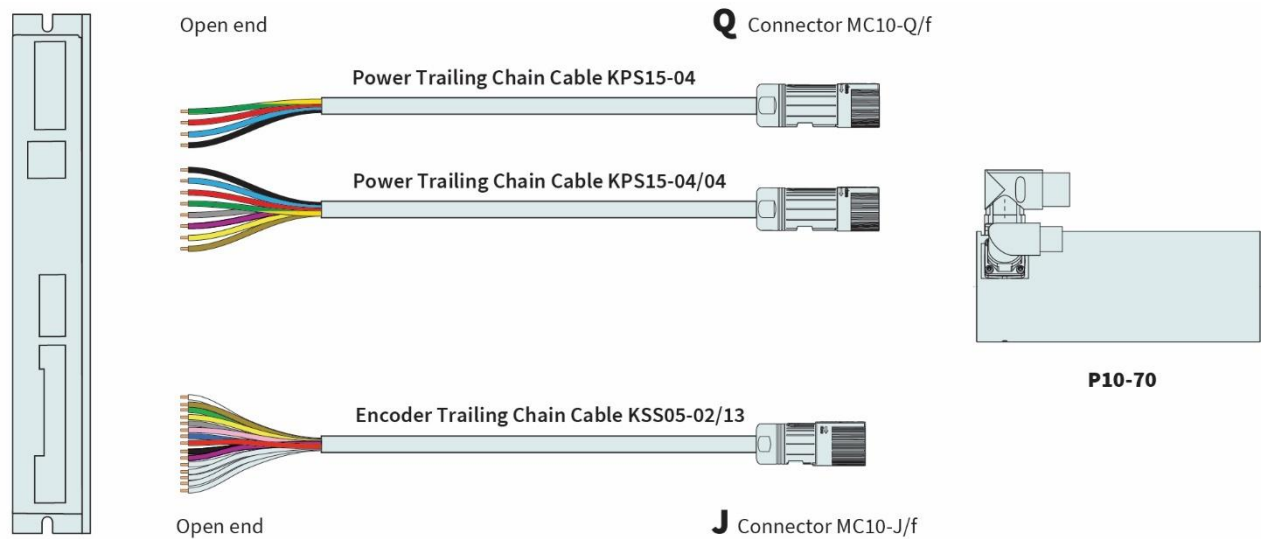

3rd party Drive

Order Overview

Dxx	Power Cable	Encoder Cable	Position Feedback	Temperature Feedback via Power Cable	Temperature Feedback via Encoder Ca.	Halls witch Signals	Ref. Signal
D04	KPS15-04-_/Q-...	KSS05-02/13-_/J-...	Sin/Cos 1Vpp	---	Pt1000	Hall U/V/W	Ref
	KPS15-04/04-_/Q-...	KSS05-02/13-_/J-...	Sin/Cos 1Vpp	Pt1000	Pt1000	Hall U/V/W	Ref
D05	KPS15-04-_/Q-...	KSS05-02/13-_/J-...	Sin/Cos 1Vpp	---	PTC	Hall U/V/W	Ref
	KPS15-04/04-_/Q-...	KSS05-02/13-_/J-...	Sin/Cos 1Vpp	PTC	PTC	Hall U/V/W	Ref
D24	KPS15-04-_/Q-...	KSS05-02/13-_/J-...	A/B 1µm	---	Pt1000	Hall U/V/W	Ref
	KPS15-04/04-_/Q-...	KSS05-02/13-_/J-...	A/B 1µm	Pt1000	Pt1000	Hall U/V/W	Ref
D24S	KPS15-04-_/Q-...	KSS05-02/13-_/J-...	A/B 5µm	---	Pt1000	Hall U/V/W	Ref
	KPS15-04/04-_/Q-...	KSS05-02/13-_/J-...	A/B 5µm	Pt1000	Pt1000	Hall U/V/W	Ref

D25	KPS15-04-_/Q-...	KSS05-02/13-_/J-...	A/B 1µm	---	PTC	Hall U/V/W	Ref
	KPS15-04/04-_/Q-...	KSS05-02/13-_/J-...	A/B 1µm	PTC	PTC	Hall U/V/W	Ref
D25S	KPS15-04-_/Q-...	KSS05-02/13-_/J-...	A/B 5µm	---	PTC	Hall U/V/W	Ref
	KPS15-04/04-_/Q-...	KSS05-02/13-_/J-...	A/B 5µm	PTC	PTC	Hall U/V/W	Ref
D26	KPS15-04-_/Q-...	KSS05-02/13-_/J-...	A/B 1µm	---	PTC SE	Hall U/V/W	Ref
	KPS15-04/04-_/Q-...	KSS05-02/13-_/J-...	A/B 1µm	PTC SE	PTC SE	Hall U/V/W	Ref
D34	KPS15-04-_/Q-...	KSS05-02/13-_/J-...	BiSS-C	---	Pt1000	Hall U/V/W	---
	KPS15-04/04-_/Q-...	KSS05-02/13-_/J-...	BiSS-C	Pt1000	---	Hall U/V/W	---

Power Cables

Item	Description	Item-No.
KPS15-04-.../Q-10	Power Trailing Chain Cable .../Q, 10 m for Dxx	0150-2376
KPS15-04-_/Q-	Power Trailing Chain Cable .../Q, für Dxx, Custom length	0150-3491
KPS15-04	Power Trailing Chain Cable P10-70 (per m)	0150-2257
KPS15-04/04.../Q-10	Power Trailing Chain Cable .../Q, 10 m for Dxx	0150-3654
KPS15-04/04-_/Q-	Power Trailing Chain Cable .../Q, für Dxx, Custom length	0150-3579
KPS15-04/04	Power Trailing Chain Cable P10-...-Dxx (per m)	0150-2269

Encoder Cables

Item	Description	Item-No.
KSS05-02/13-.../J-10	Encoder Trailing Chain Cable .../J, 10 m for Dxx	0150-2377
KSS05-02/13-_/J-	Encoder Trailing Chain Cable ./J, für Dxx, Custom length	0150-3492
KSS05-02/13	Encoder Trailing Chain Cable P10-...-Dxx (per m)	0150-2259

Extension Cables

Item	Description	Item-No.
KPS15-04-Q/Q-	Power Trailing Chain Cable Q/Q-, Custom length	0150-3414
KPS15-04/04-Q/Q-	Power Trailing Chain Cable Q/Q-, Custom length	0150-4214
KSS05-02/13-J/J-	Encoder Trailing Chain Cable J/J, für Dxx, Custom length	0150-3996

Connectors

Item	Description	Item-No.
MC10-Q/f	Connector Power PS10-70	0150-2268
MC10-J/f	Connector Encoder PS10-70	0150-2269

7.3 Wiper with exchangeable end pieces

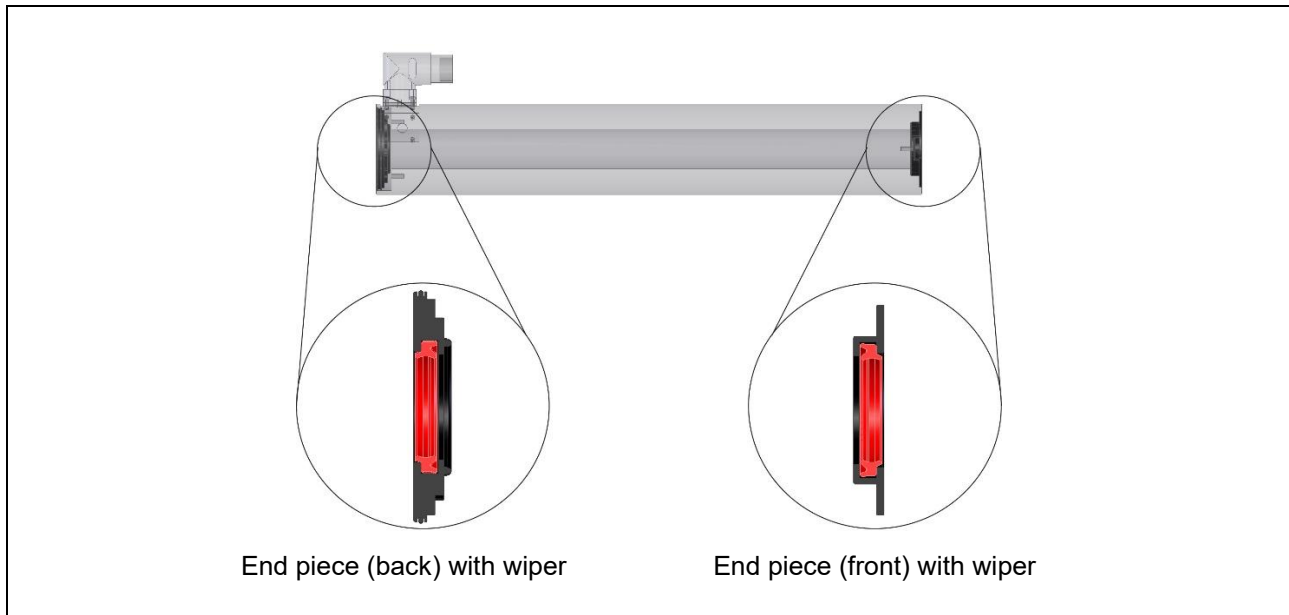

The stators are equipped as standard with wipers. This simplifies maintenance and the maintenance cycles can be extended. The wiper effects that the lubricant is dispensed metered and does not leak outside of the stator. The lubricant is less dirty.



If the end piece (front) is firmly casted, it can not be replaced. In this case, only the wiper * is substituted.

Ordering information

Item	Description	Item-No.
PA10-AV70	Stator end piece front side with wiper	0150-3560
PA10-AH70	Stator end piece back side with wiper	0150-3561
PAW 01-28*	Wiper for PL01-28	0150-3133

7.4 Wiper with lubricant depot

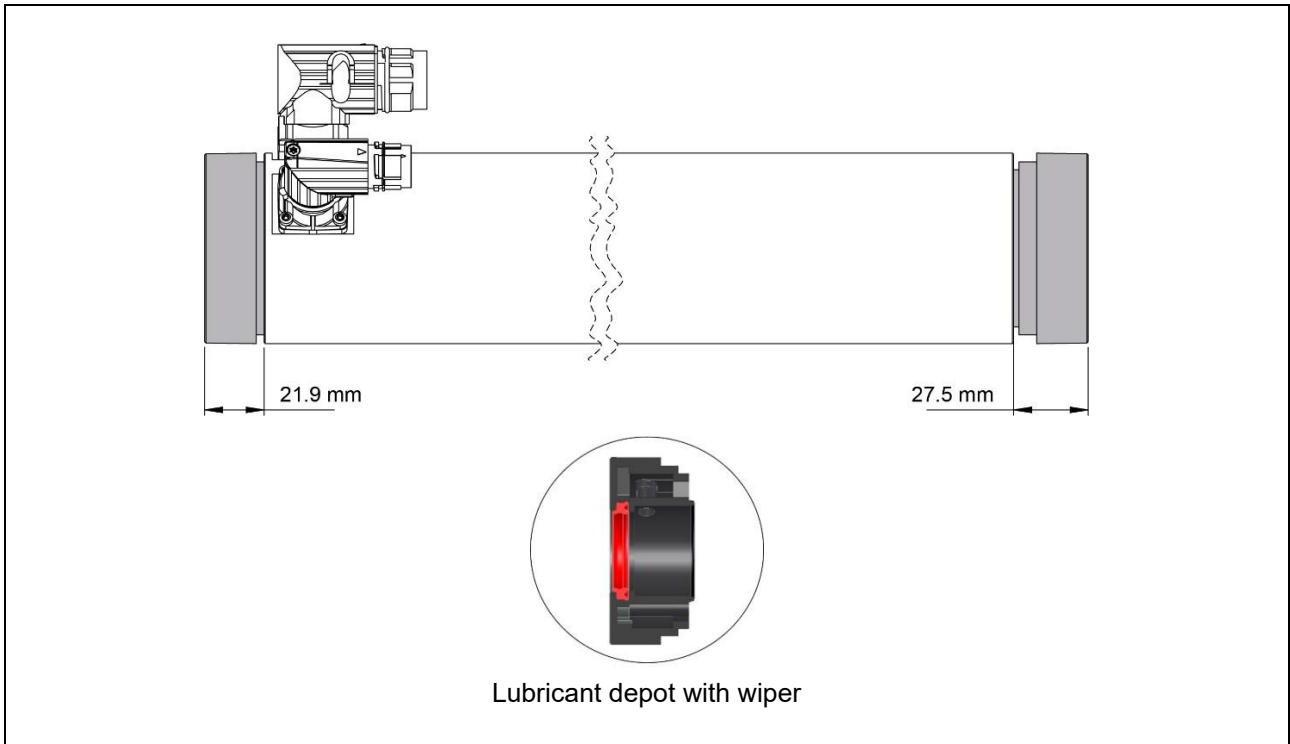

If the stators are equipped with lubricant depot, lubrication can be optimally regulated. It releases only as much lubricant as necessary. The maintenance is simplified and maintenance cycles are extended.



Per lubricant depot, the installation space required for the stator in the longitudinal direction increased by the length indicated in the illustration.

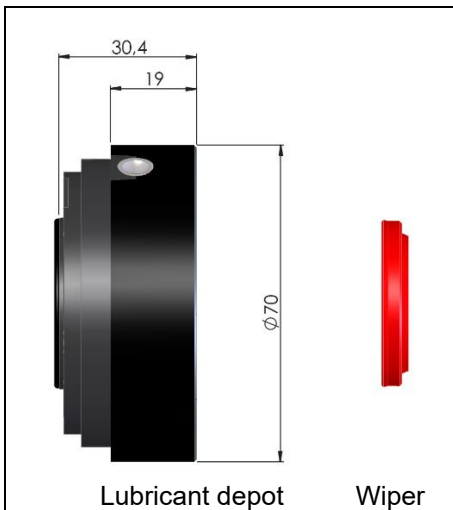

Material

Fettdepot: Ryton
Wiper: H-PU

Ordering information

Item	Description	Item-No.
PA10-70/28	Lubricant depot for PS10-70 with wiper + Lubricant (6 ml)	0150-3543

7.5 Bearing kit with exchangeable end pieces

7.5.1 Overview

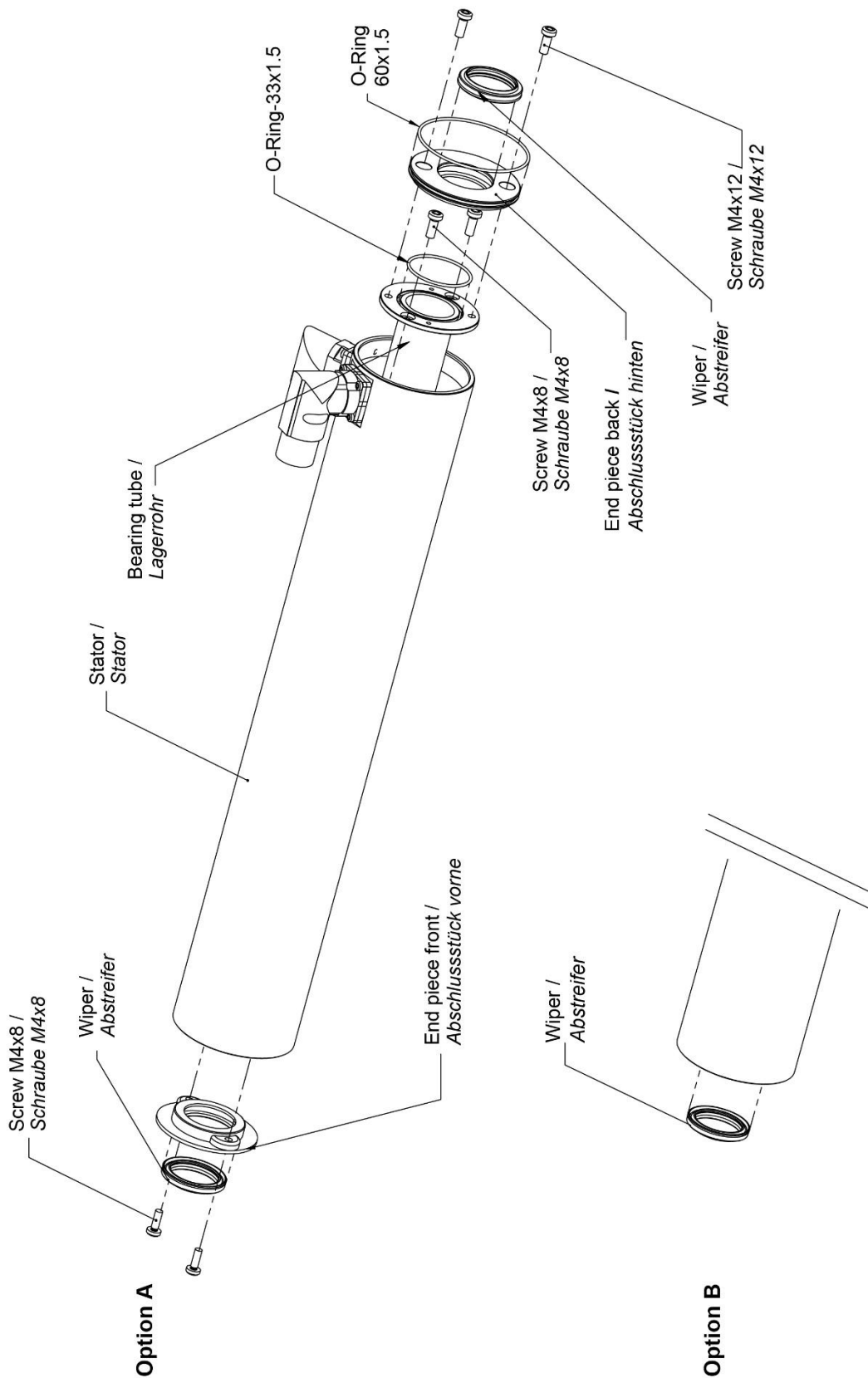

7.5.2 Mounting

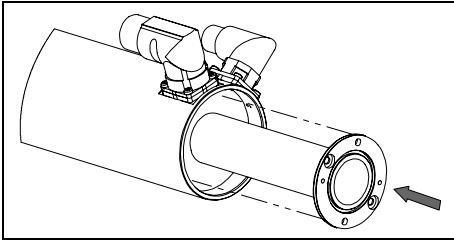

- 1. Insert bearing tube.**
Bearing tube is already lubricated with initial lubricant.

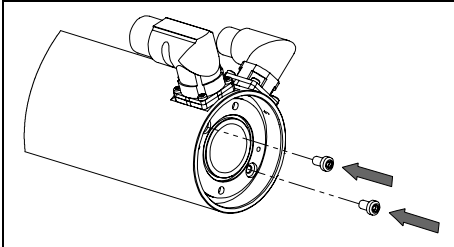

- 2. Tighten the fastening screws with 2.4 Nm.**
Screws are already coated with threadlocker (Tuflok).

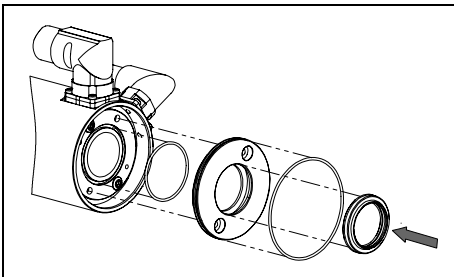

- 3. Assemble end piece (back).**
The end piece, the seals and the wiper are assembled and positioned on the stator.

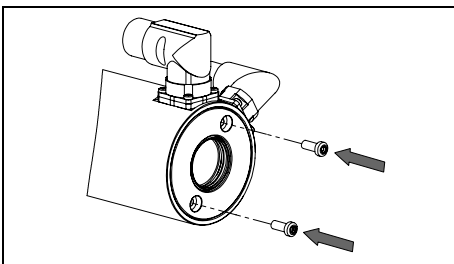

- 4. Tighten the fastening screws with 2.4 Nm.**
Screws are already coated with threadlocker (Tuflok).

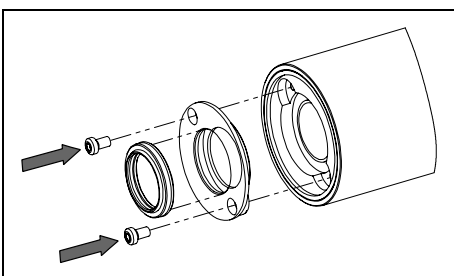

- 5. Option A: Assemble end piece (front).**
Assemble the end piece with the wiper and tighten it with fastening screws (2.4 Nm torque). Screws are already coated with threadlocker (Tuflok).

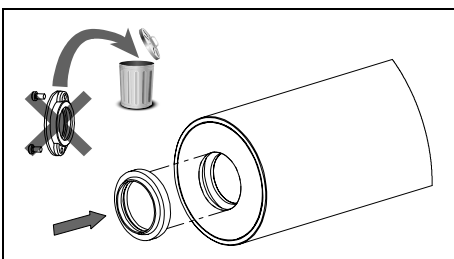

- 5. Option B: Exchange wiper.**

Important! For motors with casted end piece only the wiper has to be exchanged!

The bearing sets for the stators PS10-70 can be found in the LinMot eShop <https://shop.linmot.com/>

7.6 Bearing kit with lubricant depot

7.6.1 Overview

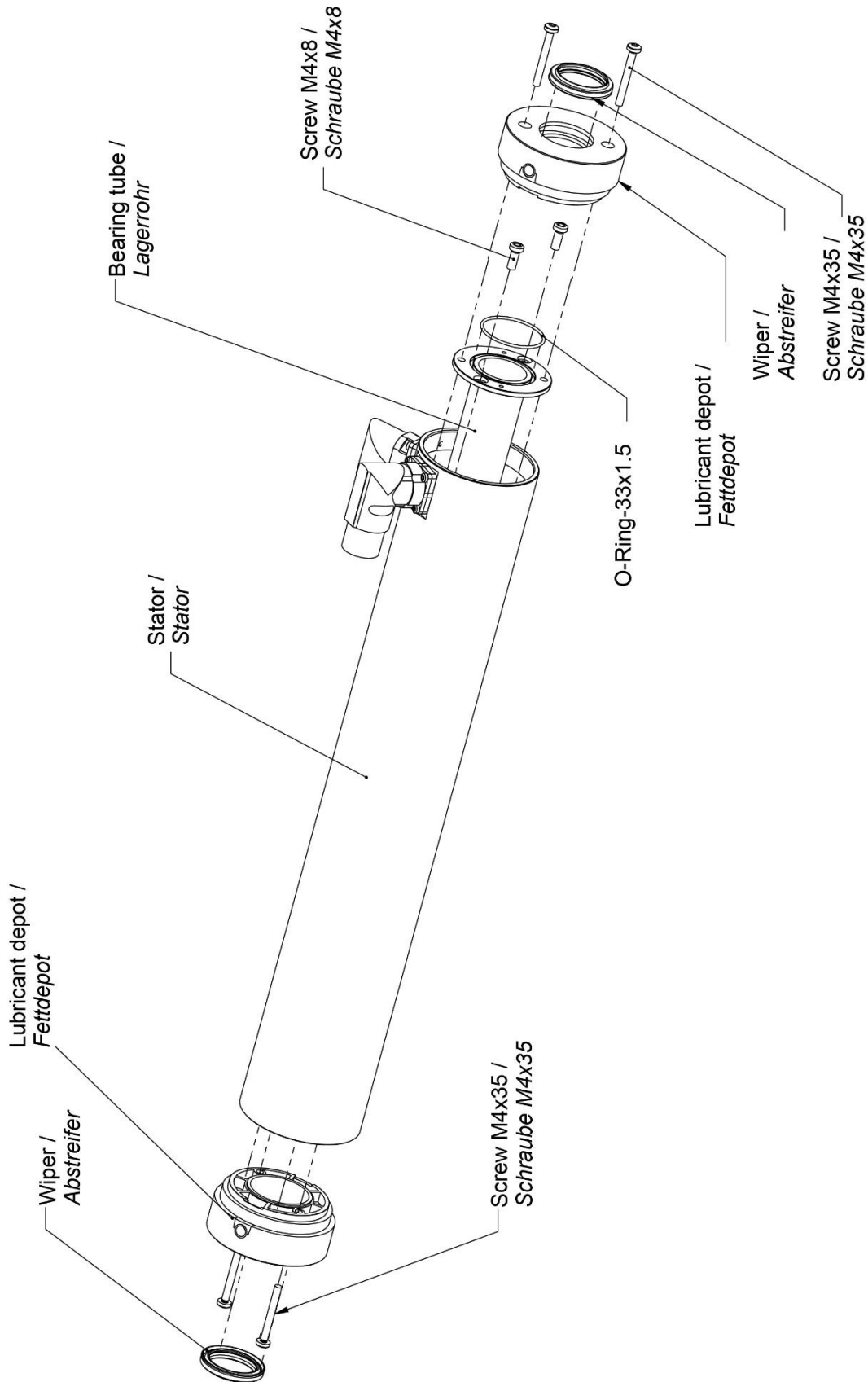

7.6.2 Mounting

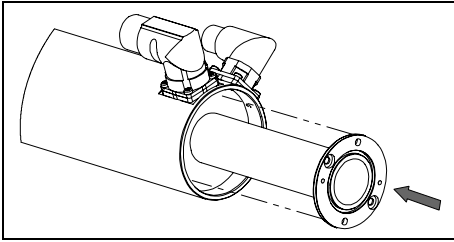

- 1. Insert bearing tube.**
Bearing tube is already lubricated with initial lubricant.

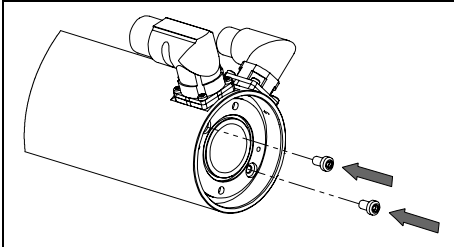

- 2. Tighten the fastening screws with 2.4 Nm.**
Screws are already coated with threadlocker (Tuflok).

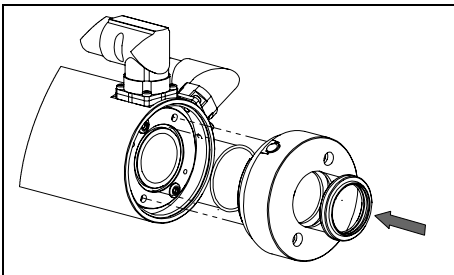

- 3. Assemble lubricant depot (back).**
The lubricant depot, the seal and the wiper are assembled and positioned on the stator.

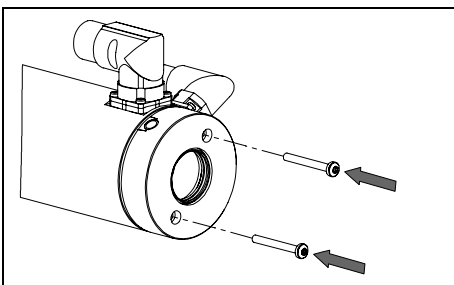

- 4. Tighten the fastening screws with 2.4 Nm.**
Screws are already coated with threadlocker (Tuflok).

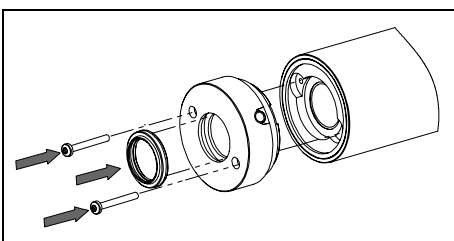

- 5. Insert lubricant depot (front).**
Assemble the lubricant depot with the wiper and tighten it with fastening screws (2.4 Nm torque). Screws are already coated with threadlocker (Tuflok).

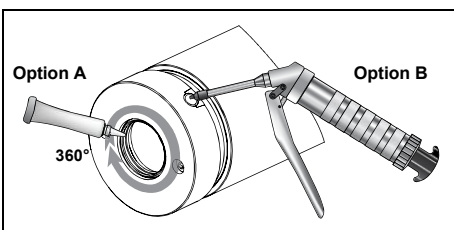

- 6. Lubrication**
Application of the lubricant on the surface behind the used wiper (Option A) or via the grease nipple with a hand press (Option B).

Item	Description	Item-No.
PA10-70/28	Lubricant depot for PS10-70 with wiper + lubricant (6 ml) Important! Bearing kit must be ordered separately.	0150-3543

7.7 Mounting flanges

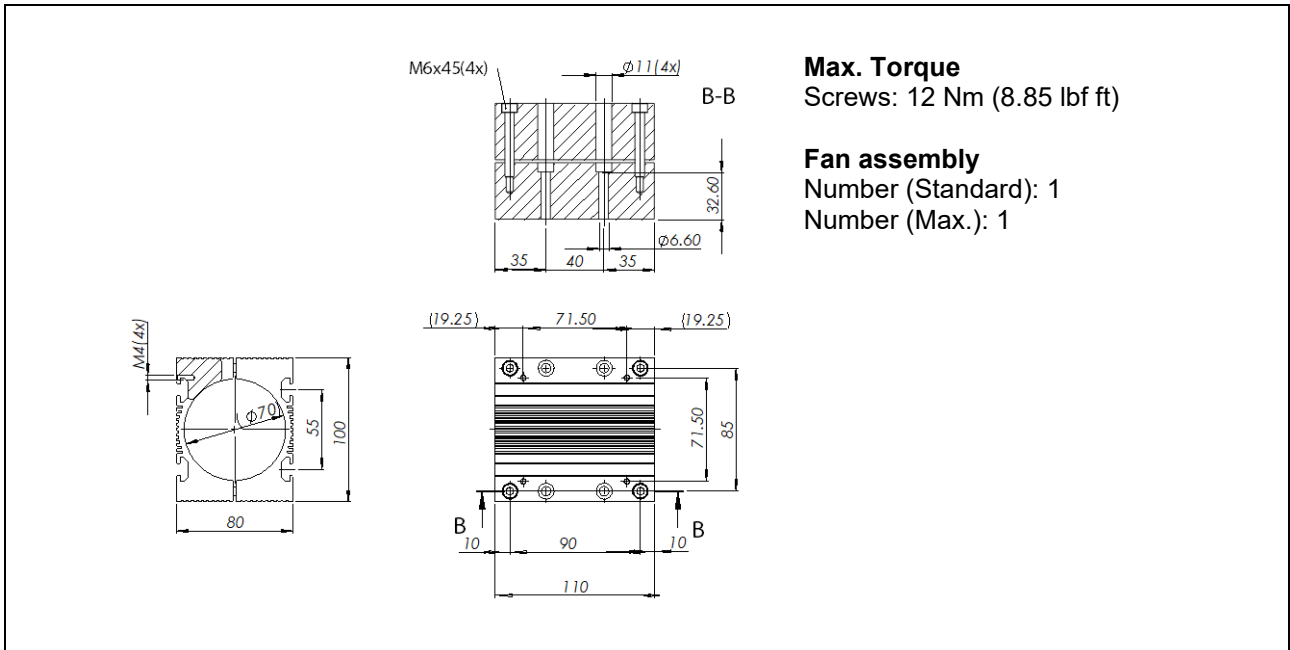

Max. Torque
Screws: 12 Nm (8.85 lbf ft)

Fan assembly
Number (Standard): 1
Number (Max.): 1

Article	Description	Weight [g / oz]	Item-No
PF10-70x110	Flange for PS10-70x80	1015 / 35.8	0150-2272

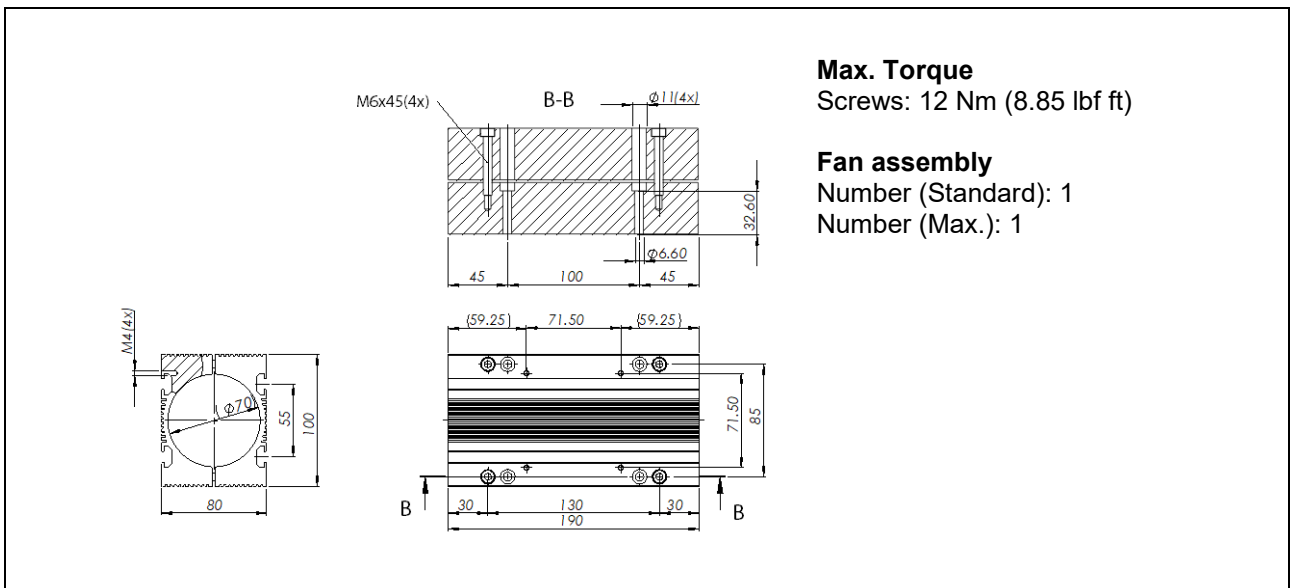

Max. Torque
Screws: 12 Nm (8.85 lbf ft)

Fan assembly
Number (Standard): 1
Number (Max.): 1

Article	Description	Weight [g / oz]	Item-No
PF10-70x190	Flange for PS10-70x160	1776 / 62.6	0150-2273

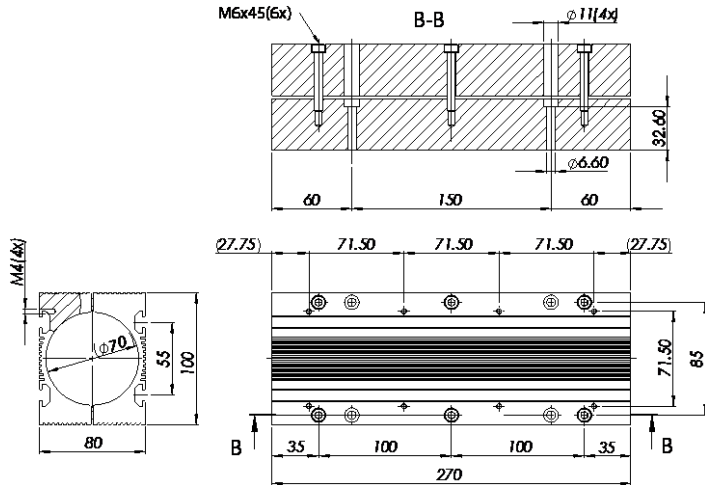

Max. Torque
Screws: 12 Nm (8.85 lbf ft)

Fan assembly
Number (Standard): 1
Number (Max.): 2

Article	Description	Weight [g / oz]	Item-No
PF10-70x270	Flange for PS10-70x240	2550 / 89.9	0150-2274

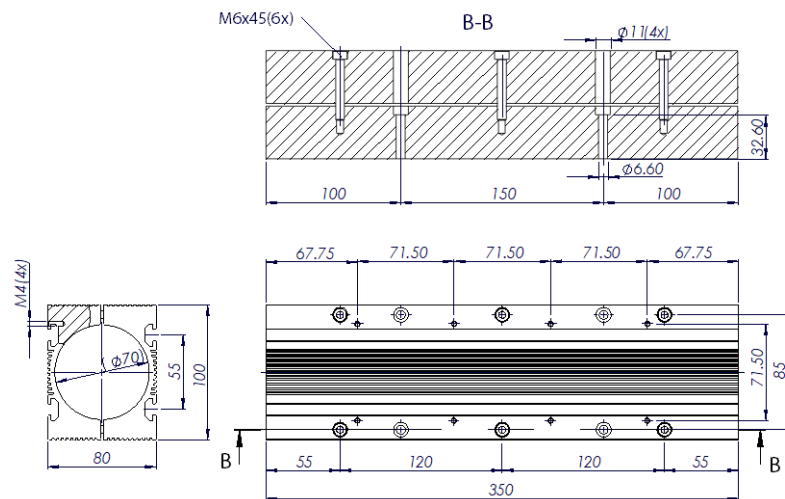

Max. Torque
Screws: 12 Nm (8.85 lbf ft)

Fan assembly
Number (Standard): 2
Number (Max.): 2

Article	Description	Weight [g / oz]	Item-No
PF10-70x350	Flange for PS10-70x320	3311 / 116.8	0150-2290

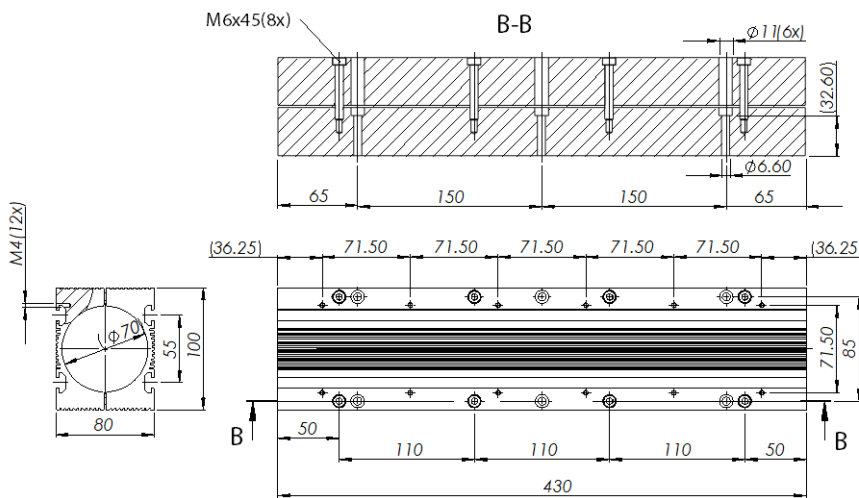

Max. Torque
Screws: 12 Nm
(8.85 lbf ft)

Fan assembly
Number (Standard): 2
Number (Max.): 3

Article	Description	Weight [g / oz]	Item-No
PF10-70x430	Flange for PS10-70x400	4056 / 143.1	0150-2276

7.8 Fan kits for flanges

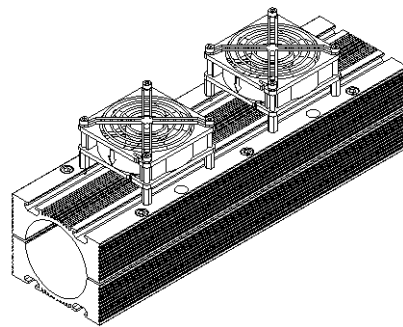
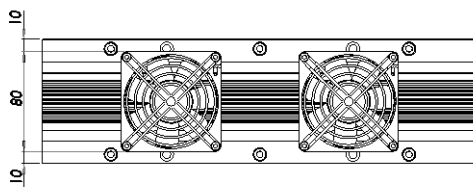

Power Supply Fan
24 VDC, 120 mA

Air flow
80 m³ / h

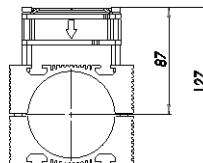
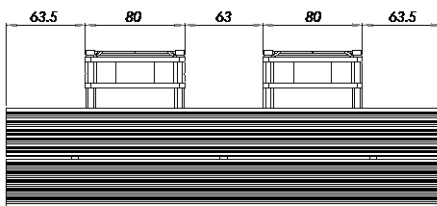

Item	Description	Item-No.
HV01-37 / 48	Fan Kit for H01-37 / 48 and PF02-37 / 48 composed of: 1 x Fan, 4 x cylinder screw M4 x 30, 4 x square nut M4, 4 x spacer M4 x 16	0150-5051

7.9 Fluid cooling flanges

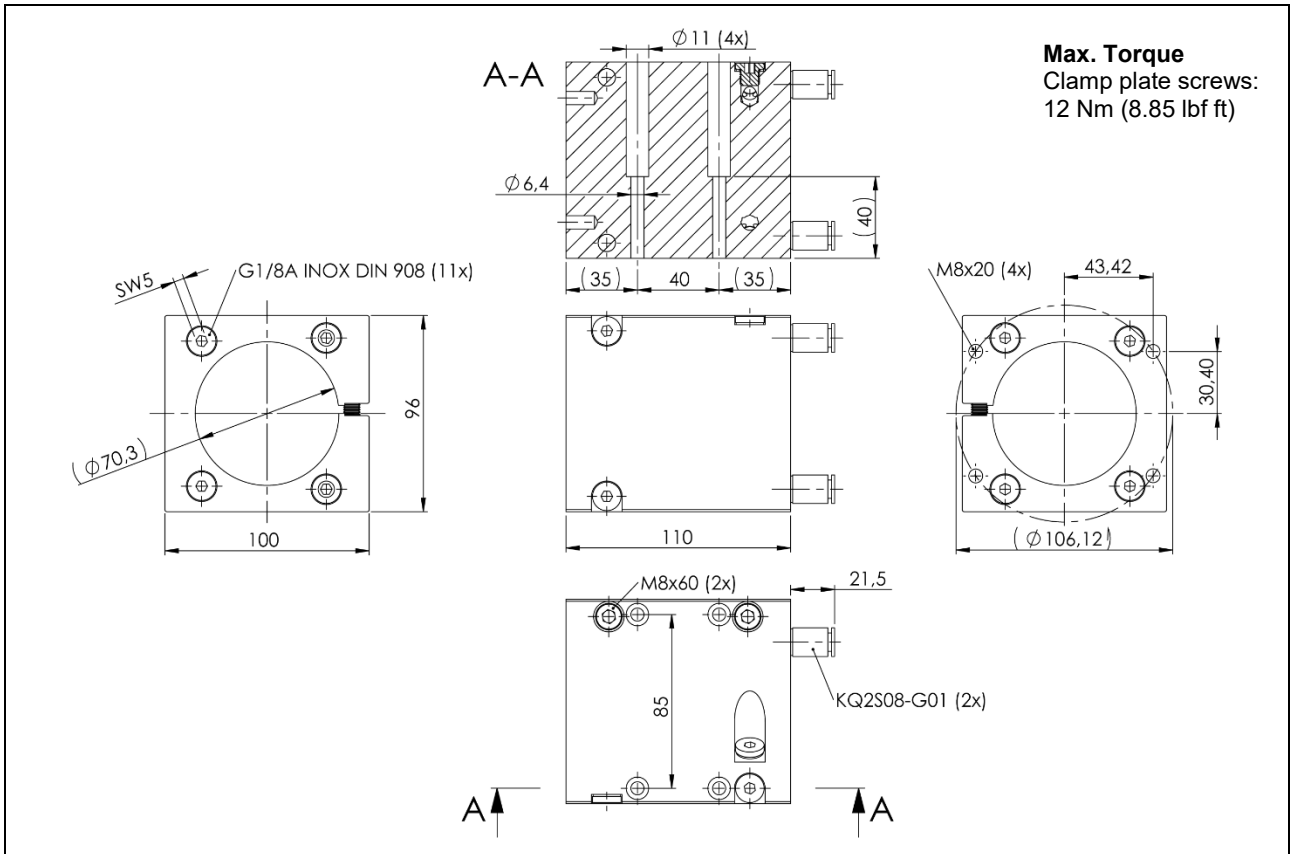

Article	Description	Weight [g / oz]	Item-No
PF11-70x110-FC	Flange for PS10-70x80 fluid cooling	1641 / 57.9	0150-2822

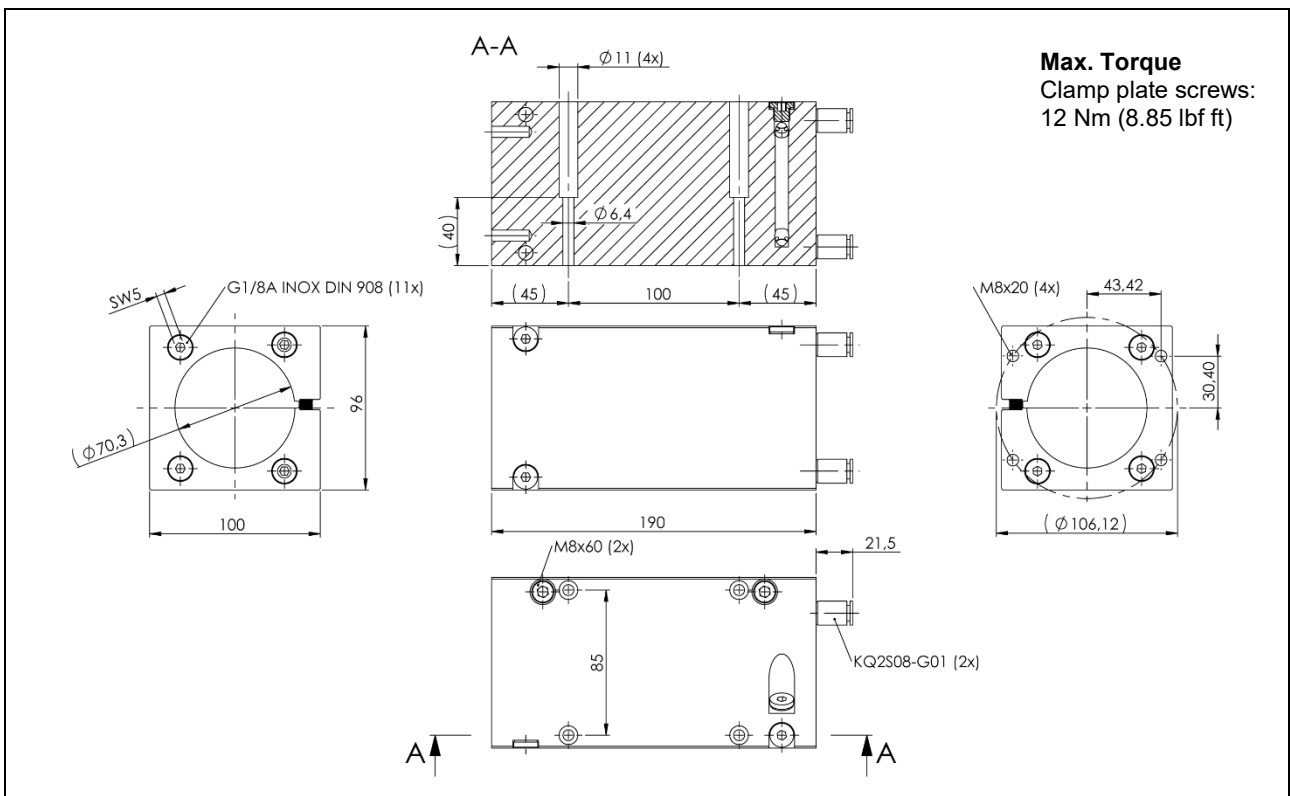

Article	Description	Weight [g / oz]	Item-No
PF11-70x190-FC	Flange for PS10-70x160 fluid cooling	2825 / 99.6	0150-2823

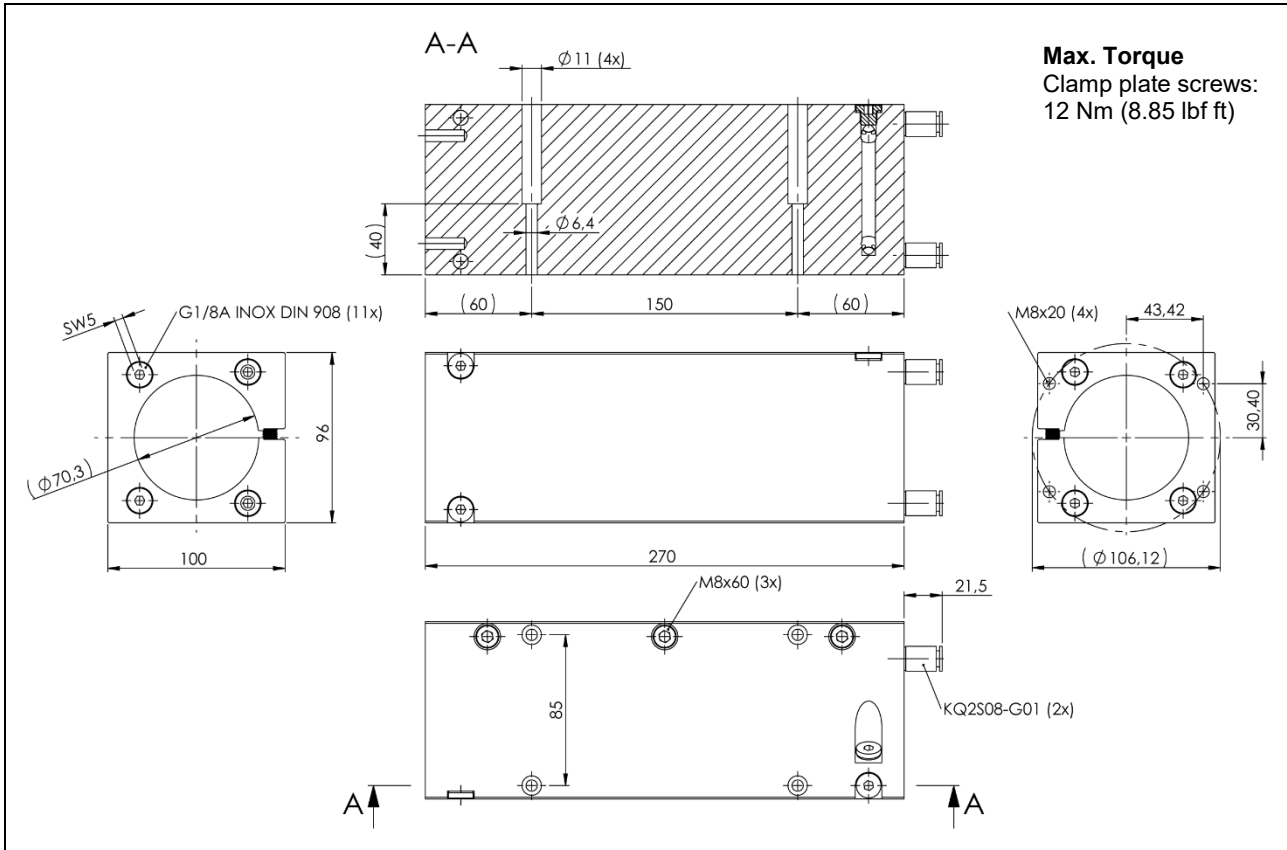

Max. Torque
Clamp plate screws:
12 Nm (8.85 lbf ft)

Article	Description	Weight [g / oz]	Item-No
PF11-70x270-FC	Flange for PS10-70x240 fluid cooling	4000 / 141	0150-2824

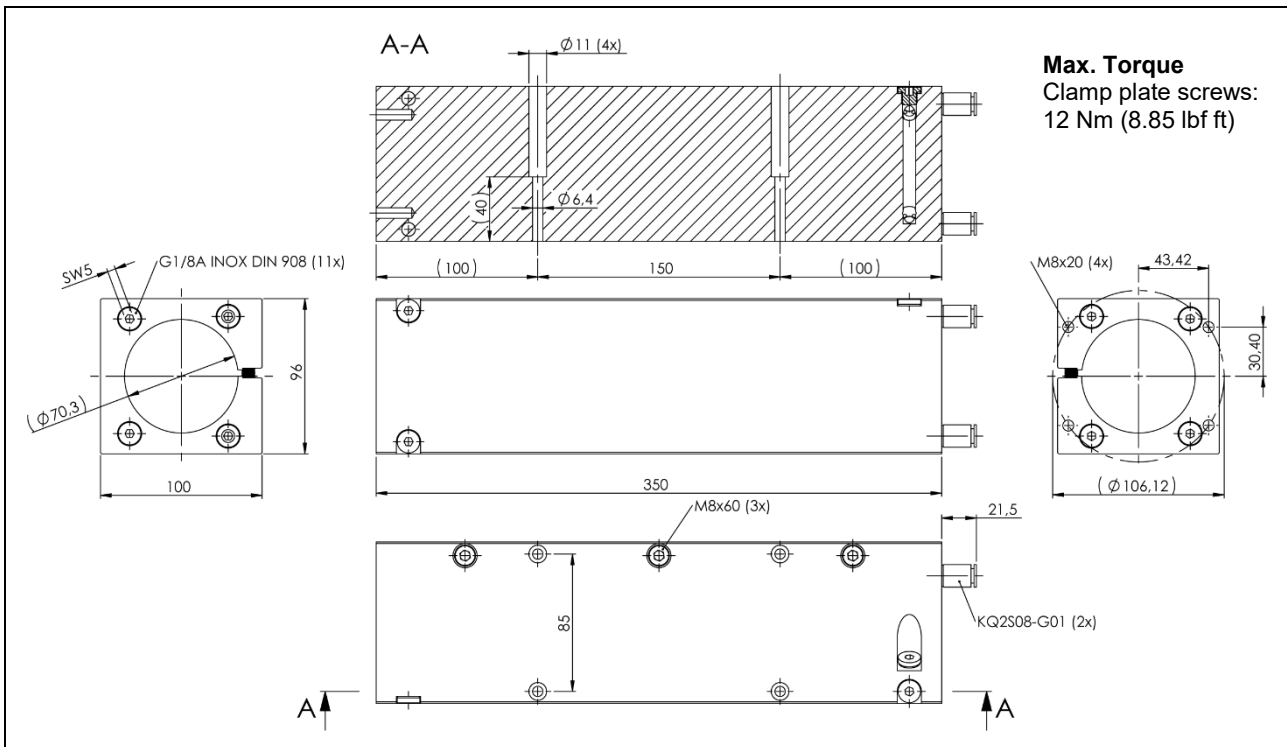

Max. Torque
Clamp plate screws:
12 Nm (8.85 lbf ft)

Article	Description	Weight [g / oz]	Item-No
PF11-70x350-FC	Flange for PS10-70x320 fluid cooling	5185 / 182.9	0150-2825

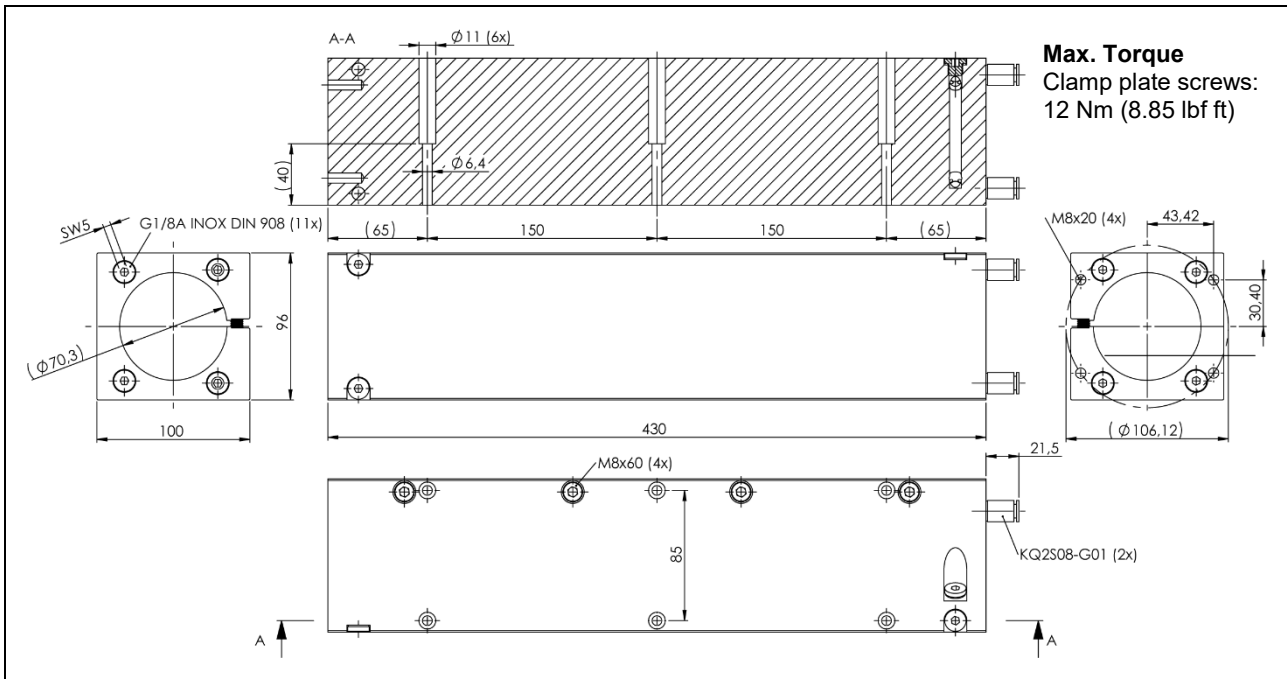

Article	Description	Weight [g / oz]	Item-No
PF11-70x430-FC	Flange for PS10-70x400 fluid cooling	6325 / 223.1	0150-2826

7.10 Slider mounting kits

7.10.1 Fixed bearing

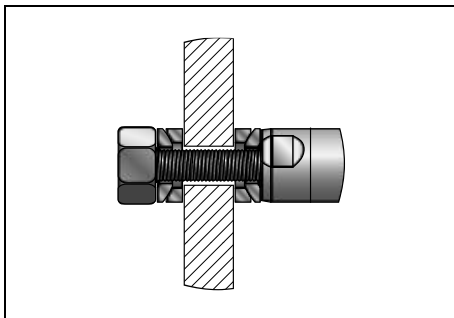

Slider mounting kit consists of a spring washer, a pair of spherical washers, and a pair of conical seats. It allows the slider to be fixed in the direction of motion. It also helps to compensate for radial and angle offset.

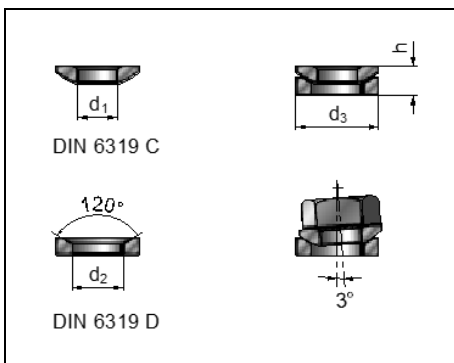

Material

Spherical washer / conical seat: case hardened steel

Item	Item No.	Slider	Thread	d1	d2	d3	h
PLF01-28	0150-3087	28mm	M10	10.5mm (0.41in)	12mm (0.47in)	21mm (0.83in)	6.5mm (0.26in)
PLF01-28 (Stainless-st.)	0150-3297	28mm	M10	10.5mm (0.41in)	12mm (0.47in)	21mm (0.83in)	6.5mm (0.26in)

7.10.2 Floating bearing

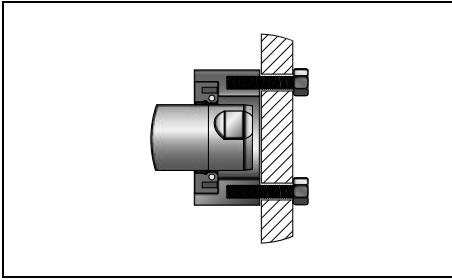

Floating bearing assembly that permits radial adjustment of slider position and permits a small amount of radial and axial movement.

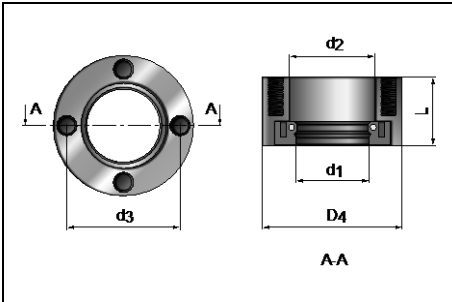

Material

Housing:
Bearing:

Stainless steel 1.4305
Nitrile butadiene rubber
Spring steel DIN17223

Item	Item No.	Slider	Thread	d1	d2	d3	D4	L
PLL01-28	0150-3094	28mm	M5	28mm (1.10in)	32mm (1.26in)	40mm (1.57in)	48mm (1.89in)	20mm (0.79in)

7.10.3 Complete mounting kit

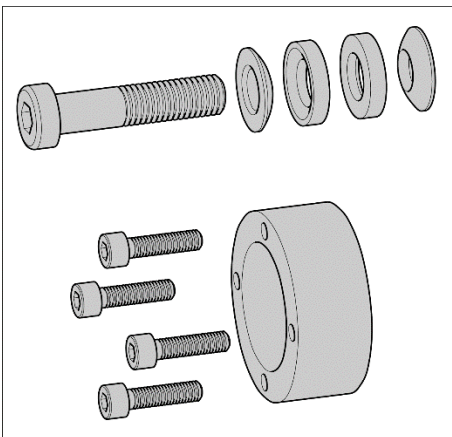

This kit provides one set of mounting parts for each end of the slider.

Ordering information

Item	Description	Item-No.
PLM01-28-MK	Mounting kit for PL01-28 slider composed of: 1 Spherical washer & conical seat (0150-3087) 1 Floating Bearing (0150-3094) 1 Socket hd. cap screw * DIN 912 / M10, L=35 mm (L=1.38 in) 4 Socket hd. cap screw * DIN 912 / M5, L=20 mm (L=0.78 in)	0150-3095

* For use with 12 mm (1/2 in) thick mounting plates.

8 Maintenance and test instructions

8.1 Stator checking

The following tables show the resistive value between the different connector pins for each stator type. If the value is not within a range of +/- 10% the stator may be damaged (temperature of the stator for all measurements: 25°C).

PS10-70x80U-...

...-BL-QJ (0150-1291) ...-BL-QJ-D24 (0150-4130) ...-BL-QJ-D25S (0150-4603)
 ...-BL-QJ-D04 (0150-4263) ...-BL-QJ-D24S (0150-4598) ...-BL-QJ-D26 (0150-4517)
 ...-BL-QJ-D05 (0150-4608) ...-BL-QJ-D25 (0150-5760) ...-BL-QJ-D34 (0150-4870)

Phase U / Phase V	Pin 1 / Pin 4	13 Ω @ 25 °C
Phase V / Phase W	Pin 4 / Pin 3	13 Ω @ 25 °C
Phase W / Phase U	Pin 3 / Pin 1	13 Ω @ 25 °C
Casing	Any phases / Casing	> 200 MΩ @ 25 °C
Temp + / Temp - Pt1000 + / Pt1000 - PTC + / PTC -	Pin A / Pin B	200 kΩ @ 25 °C (supply off) 1097 Ω @ 25 °C < 400 Ω @ 25 °C

PS10-70x160U-...

...-BL-QJ (0150-1292) ...-BL-QJ-D24 (0150-4131) ...-BL-QJ-D25S (0150-4601)
 ...-BL-QJ-D04 (0150-4261) ...-BL-QJ-D24S (0150-4596) ...-BL-QJ-D26 (0150-4515)
 ...-BL-QJ-D05 (0150-4606) ...-BL-QJ-D25 (0150-5761) ...-BL-QJ-D34 (0150-4871)

Phase U / Phase V	Pin 1 / Pin 4	8.3 Ω @ 25 °C
Phase V / Phase W	Pin 4 / Pin 3	8.3 Ω @ 25 °C
Phase W / Phase U	Pin 3 / Pin 1	8.3 Ω @ 25 °C
Casing	Any phases / Casing	> 200 MΩ @ 25 °C
Temp + / Temp - Pt1000 + / Pt1000 - PTC + / PTC -	Pin A / Pin B	200 kΩ @ 25 °C (supply off) 1097 Ω @ 25 °C < 400 Ω @ 25 °C

PS10-70x240U-...

...-BL-QJ (0150-1293) ...-BL-QJ-D24 (0150-4132) ...-BL-QJ-D25S (0150-4602)
 ...-BL-QJ-D04 (0150-4262) ...-BL-QJ-D24S (0150-4597) ...-BL-QJ-D26 (0150-4516)
 ...-BL-QJ-D05 (0150-4607) ...-BL-QJ-D25 (0150-5762) ...-BL-QJ-D34 (0150-4872)

Phase U / Phase V	Pin 1 / Pin 4	6.3 Ω @ 25 °C
Phase V / Phase W	Pin 4 / Pin 3	6.3 Ω @ 25 °C
Phase W / Phase U	Pin 3 / Pin 1	6.3 Ω @ 25 °C
Casing	Any phases / Casing	> 200 MΩ @ 25 °C
Temp + / Temp - Pt1000 + / Pt1000 - PTC + / PTC -	Pin A / Pin B	200 kΩ @ 25 °C (supply off) 1097 Ω @ 25 °C < 400 Ω @ 25 °C

PS10-70x320U-...

...-BL-QJ (0150-1284) ...-BL-QJ-D24 (0150-4133) ...-BL-QJ-D25S (0150-4603)
 ...-BL-QJ-D04 (0150-4263) ...-BL-QJ-D24S (0150-4598) ...-BL-QJ-D26 (0150-4517)
 ...-BL-QJ-D05 (0150-4608) ...-BL-QJ-D25 (0150-5763) ...-BL-QJ-D34 (0150-4873)

Phase U / Phase V	Pin 1 / Pin 4	5.5 Ω @ 25 °C
Phase V / Phase W	Pin 4 / Pin 3	5.5 Ω @ 25 °C

Phase W / Phase U	Pin 3 / Pin 1	5.5 Ω @ 25 °C
Casing	Any phases / Casing	> 200 MΩ @ 25 °C
Temp + / Temp - Pt1000 + / Pt1000 - PTC + / PTC -	Pin A / Pin B	200 kΩ @ 25 °C (supply off) 1097 Ω @ 25 °C < 400 Ω @ 25 °C

PS10-70x400U-...

...-BL-QJ (0150-1294)

...-BL-QJ-D24 (0150-4134)

...-BL-QJ-D25S (0150-4604)

...-BL-QJ-D04 (0150-4264)

...-BL-QJ-D24S (0150-4599)

...-BL-QJ-D26 (0150-4518)

...-BL-QJ-D05 (0150-4609)

...-BL-QJ-D25 (0150-5764)

...-BL-QJ-D34 (0150-4874)

Phase U / Phase V	Pin 1 / Pin 4	6.9 Ω @ 25 °C
Phase V / Phase W	Pin 4 / Pin 3	6.9 Ω @ 25 °C
Phase W / Phase U	Pin 3 / Pin 1	6.9 Ω @ 25 °C
Casing	Any phases / Casing	> 200 MΩ @ 25 °C
Temp + / Temp - Pt1000 + / Pt1000 - PTC + / PTC -	Pin A / Pin B	200 kΩ @ 25 °C (supply off) 1097 Ω @ 25 °C < 400 Ω @ 25 °C

8.2 Maintenance of linear motors

The stators will be shipped with an initial lubrication. Maintenance will only be required if the motors run 'dry' or there is a heavy pollution of the motors. Under normal industrial conditions (5 day, 8 h / day) one inspection every 3 months is adequate. The inspection cycle must be shortened if severe motor loads or deviating conditions exist. These conditions are for example:

- Permanent fouling
- Direct sunshine
- Low Humidity
- Outdoor operation
- Increased operating temperature

8.2.1 Mounting

Sliders with a length ≤ 500 mm (20 in) are to be inserted in a clean condition in the stator.

Sliders with a length > 500 mm (20 in) must be lubricated with LU02. 4 g of lubricant per meter slider is enough to create a film of lubricant on the surface of the sliders. 4 g (0.14 oz) is about ½ of a hazel-nut. The grease can be applied by hand or with a soft paper towel.

If wipers are used then the inner side of the seals of the wipers must be lubricated as well.



Basically, it must be ensured that only a thin film of grease is applied. 4 g of grease per 1000 mm of slider length is sufficient for this purpose. Over lubrication leads to a gumming of the grease, which appears particularly at higher operating temperatures! In this case, a complete cleaning of the motor has to be made.

8.2.2 Inspection

Inspections have to be executed according to the operating condition and the load of motors. Following points have to be checked during inspection:

- Is a film of lubricant on the slider? If not -> Lubrication
- Is the wiper (if existent) without visible wear? If not -> Replace wipers
- Is the lubricant homogeneous and not decomposed? In case of negation -> Cleaning (stator, slider) + Lubrication
- Can the slider be moved easily? If not -> Cleaning (stator, slider) + Lubrication

8.2.3 Cleaning

- Pull the sliders carefully out of the stator.
Attention! Strong magnetic attraction forces (note safety instructions on page 5)!
Use non magnetic material (e.g. wood) to cover close-by iron constructions.
- Clean slider and stator with a soft disposable paper, ideally with the help of LU06 cleaning spray (or methylated spirits or alcohol).
- Afterwards, lubricate the bore of the stators with about 2-3 g (0.1 oz) grease LU02.
There should only be a slight film of lubricant.
Note: Do not over lubricate!
- Finally, slider should be lubricated according to the chapter 'mounting'.

8.2.4 Cleaning agent / Lubricant

For the cleaning of LinMot stators and sliders cleaning agent spray LU06 is recommended.
To improve the sliding characteristics between the stainless steel surface of the slider and the plastic slide bearing the LinMot lubricant LU02 is prescribed.

Ordering information

Item	Description	Item-No.
LU06-250	Klüberfood NH1 4-002 Spray* (250 ml)	0150-2394
LU02-08	Lubricant for linear motors ** (8 g)	0150-1953
LU02-50	Lubricant for linear motors ** (50 g)	0150-1954
LU02-1000	Lubricant for linear motors ** (1000 g)	0150-1955

* LinMot Spray LU06 corresponds to KLÜBERFOOD NH1 4-002 which was developed for the food processing industry.

** LinMot LU02 Lubricant corresponds to KLÜBERSYNTH UH1 14-31 which was developed for the food processing industry.

9 Storage, transport, installation altitude

- Sliders are to be stored and transported only in the plastic containers (with cardboard inlay) provided for this purpose, or already installed and secured in LinMot P stators.
- Remove the slider from this plastic containers only for assembling.
- The storage area must be dry, dust-free, frost-free and vibration-free.
- The relative air humidity should be less than 60 %.
- Prescribed storage temperature: -15 °C...70 °C
- The motor must be protected against extreme weather conditions.
- The air in the storage area must not contain any harmful gases.
- The max. installation altitude is 2'000 m (for higher values contact LinMot) above sea level.
Beyond 1'000 m, a derating of 0.5% per 100 m must be taken into account on the rated force in the case of air cooling.

10 Dimensions

10.1 Stator

10.1.1 PS10-70x80

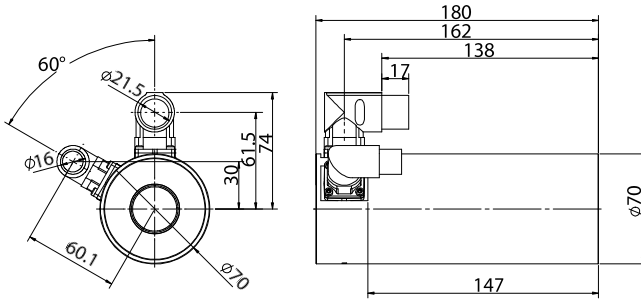

10.1.2 PS10-70x160

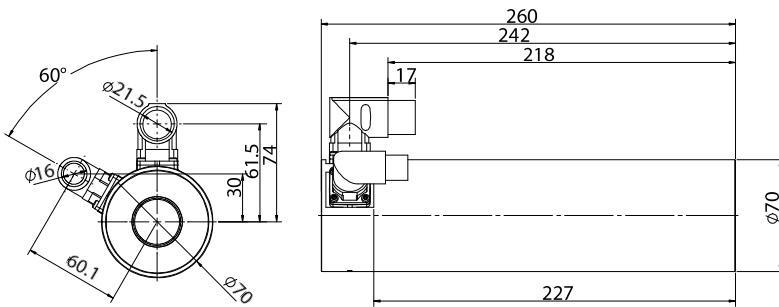

10.1.3 PS10-70x240

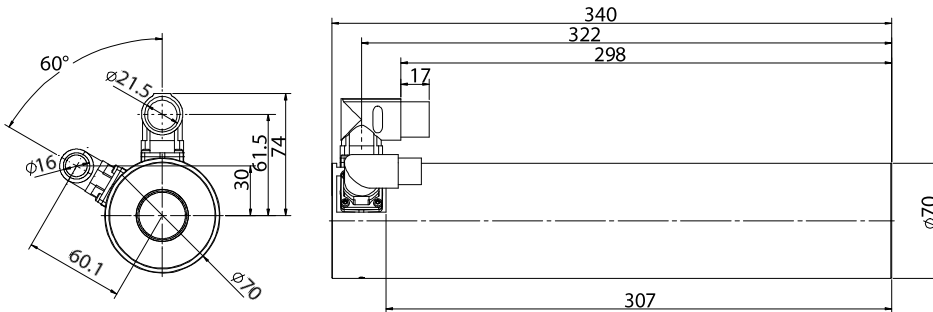

10.1.4 PS10-70x320

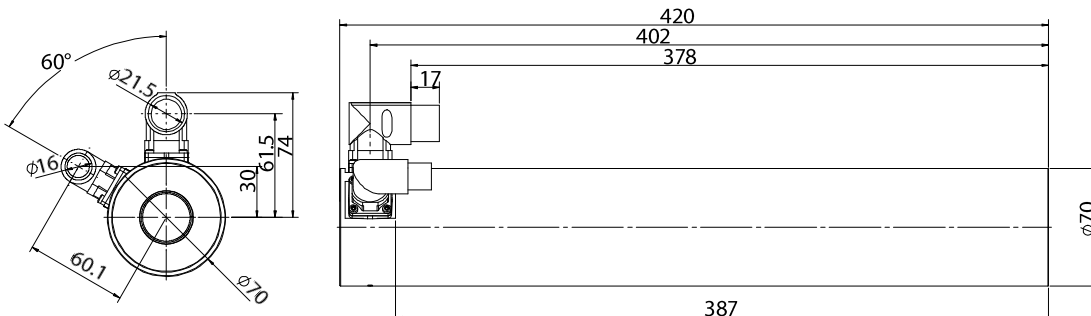

10.1.5 PS10-70x400

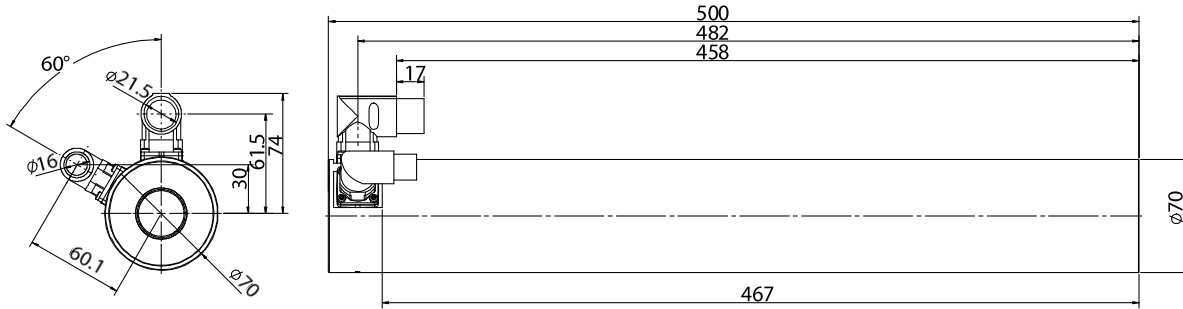

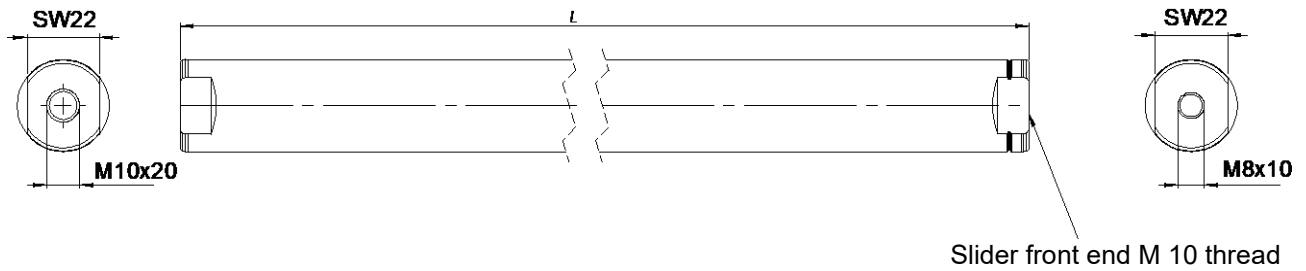

10.2 Slider



Item	Item-No.	Length L [mm / in]
PL10-28x290/240	0150-2193	290 / 11.42
PL10-28x390/340	0150-2194	390 / 15.36
PL10-28x490/440	0150-2195	490 / 19.3
PL10-28x590/540	0150-2196	590 / 23.42
PL10-28x690/640	0150-2197	690 / 27.18
PL10-28x790/740	0150-2198	790 / 31.11
PL10-28x890/840	0150-2199	890 / 35.05
PL10-28x990/940	0150-2203	990 / 39
PL10-28x1190/1140	0150-2204	1190 / 46.87
PL10-28x1390/1340	0150-2205	1390 / 54.75
PL10-28x1590/1540	0150-2206	1590 / 62.62
PL10-28x1790/1740	0150-2207	1790 / 70.5
PL10-28x1990/1940	0150-2208	1990 / 78.38

11 International Certificates

<p>Europe</p> 	<p>See chapter "EU Declaration of Conformity CE-Marking"</p>
<p>UK</p> 	<p>See chapter "UK Declaration of Conformity UKCA-Marking"</p>
<p>IECEE CB SCHEME</p>	<p>Ref. Certif. Nr. CH-8521</p>
<p>USA / Canada</p> 	<p>File Number E354430 Refers to cURus marked motors</p>

	Ref. Certif. No.
	CH-8521



IEC SYSTEM FOR MUTUAL RECOGNITION OF TEST CERTIFICATES FOR ELECTRICAL EQUIPMENT (IECEE) CB SCHEME

CB TEST CERTIFICATE

Product	Linear motor
Name and address of the applicant	NTI AG Bodenäckerstrasse 2 SWITZERLAND 8957 Spreitenbach
Name and address of the manufacturer	NTI AG Bodenäckerstrasse 2 SWITZERLAND 8957 Spreitenbach
Name and address of the factory	NTI AG Bodenäckerstrasse 2 SWITZERLAND 8957 Spreitenbach
<i>Note: When more than one factory, please report on page 2</i>	<input type="checkbox"/> Additional Information on page 2
Ratings and principal characteristics	supplied via servo drive, see TR 17-EL-0006.E02 for details
Trade mark (if any)	LinMot
Customers's Testing Facility (CTF) Stage used	---
Model / Type Ref.	PR series PS series P04 series P05 series
Additional information (if necessary may also be reported on page 2)	---
A sample of product was tested and found to be in conformity with IEC	<input type="checkbox"/> Additional Information on page 2 IEC 61000-6-2:2016 IEC 61000-6-4:2006, IEC 61000-6-4:2006/AMD1:2010 IEC 61000-6-7:2014
National differences	EU Group Differences; EU Special National Conditions; EU A-Deviations
As shown in the Test Report Ref. No. which forms part of this Certificate	17-EL-0006.E01 + .E02 + .Z01



This CB Test Certificate is issued by the National Certification Body

Electrosuisse Luppenstrasse 1 8320 Fehraltorf SWITZERLAND Signed by: Martin Plüss Date: 2017-03-13		 page 1 of 1
---	---	--

12 UL Certificate

CERTIFICATE OF COMPLIANCE

Certificate Number UL-US-L354430-11-52105102-2
Report Reference E354430-20150125
Date 5-May-2021

Issued to: NTI AG
Bodenaeckerstr 2 SPREITENBACH
Switzerland 8957

**This is to certify that
representative samples of**

NDMM2 - Incomplete Rotating Machines and Rotating
Machine Parts - Component

See Addendum Page for Product Designation(s).

Have been investigated by UL in accordance with the
component requirements in the Standard(s) indicated on
this Certificate. UL Recognized components are incomplete
in certain constructional features or restricted in
performance capabilities and are intended for installation in
complete equipment submitted for investigation to UL LLC.

Standard(s) for Safety: UL 1004-1, 2nd Ed., Issue Date: 2012-09-19, Revision
Date: 2020-11-05

Additional Information: See the UL Online Certifications Directory at
<https://iq.ulprospector.com> for additional information

This *Certificate of Compliance* does not provide authorization to apply the UL Recognized Component Mark.
Only the UL Follow-Up Services Procedure provides authorization to apply the UL Mark.

Only those products bearing the UL Recognized Component Mark should be considered as being UL Certified
and covered under UL's Follow-Up Services.

Look for the UL Recognized Component Mark on the product.

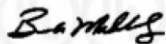

Bruce Mahrenholz, Director North American Certification Program

UL LLC

Any information and documentation involving UL Mark services are provided on behalf of UL LLC (UL) or any authorized licensee of UL. For questions, please
contact a local UL Customer Service Representative at <http://ul.com/about/ul/certifications>



CERTIFICATE OF COMPLIANCE

Certificate Number UL-US-L354430-11-52105102-2
Report Reference E354430-20150125
Date 5-May-2021

This is to certify that representative samples of the product as specified on this certificate were tested according to the current UL requirements

Model	Category Description
P10-70-SSCx160	Incomplete Motor Parts
P10-70-SSCx240	Incomplete Motor Parts
P10-70-SSCx320	Incomplete Motor Parts
P10-70-SSCx400	Incomplete Motor Parts
P10-70-SSCx480	Incomplete Motor Parts
P10-70-SSCx80	Incomplete Motor Parts
P10-70x160+	Incomplete Motor Parts
P10-70x240+	Incomplete Motor Parts
P10-70x320+	Incomplete Motor Parts
P10-70x400+	Incomplete Motor Parts
P10-70x480+	Incomplete Motor Parts
P10-70x80+	Incomplete Motor Parts
PS10-70-SSCx160	Incomplete Motor Parts
PS10-70-SSCx240	Incomplete Motor Parts
PS10-70-SSCx320	Incomplete Motor Parts
PS10-70-SSCx400	Incomplete Motor Parts
PS10-70-SSCx480	Incomplete Motor Parts
PS10-70-SSCx80	Incomplete Motor Parts
PS10-70x160+	Incomplete Motor Parts
PS10-70x240+	Incomplete Motor Parts
PS10-70x320+	Incomplete Motor Parts
PS10-70x400+	Incomplete Motor Parts
PS10-70x480+	Incomplete Motor Parts
PS10-70x80+	Incomplete Motor Parts

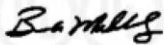

Bruce Mahrenholz, Director North American Certification Program

UL LLC

Any information and documentation involving UL Mark services are provided on behalf of UL LLC (UL) or any authorized licensee of UL. For questions, please contact a local UL Customer Service Representative at <http://ul.com/about/ullocations>



CERTIFICATE OF COMPLIANCE

Certificate Number UL-CA-L354430-31-52105102-2
Report Reference E354430-20150125
Date 5-May-2021

Issued to: NTI AG
Bodenaeckerstr 2 SPREITENBACH
Switzerland 8957

This is to certify that representative samples of NDMM8 - Incomplete Rotating Machines and Rotating Machine Parts Certified for Canada - Component
See Addendum Page for Product Designation(s).

Have been investigated by UL in accordance with the component requirements in the Standard(s) indicated on this Certificate. UL Recognized components are incomplete in certain constructional features or restricted in performance capabilities and are intended for installation in complete equipment submitted for investigation to UL LLC.

Standard(s) for Safety: CSA C22.2 NO. 100, 7th Ed., Issue Date: 2014-07-01, Revision Date: 2017-04-01

Additional Information: See the UL Online Certifications Directory at <https://iq.ulprospector.com> for additional information

This *Certificate of Compliance* does not provide authorization to apply the UL Recognized Component Mark. Only the UL Follow-Up Services Procedure provides authorization to apply the UL Mark.

Only those products bearing the UL Recognized Component Mark should be considered as being UL Certified and covered under UL's Follow-Up Services.

Look for the UL Recognized Component Mark on the product.

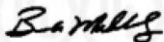

Bruce Mahrenholz, Director North American Certification Program

UL LLC

Any information and documentation involving UL Mark services are provided on behalf of UL LLC (UL) or any authorized licensee of UL. For questions, please contact a local UL Customer Service Representative at <http://ul.com/about/ul/certifications>



CERTIFICATE OF COMPLIANCE

Certificate Number UL-CA-L354430-31-52105102-2
Report Reference E354430-20150125
Date 5-May-2021

This is to certify that representative samples of the product as specified on this certificate were tested according to the current UL requirements

Model	Category Description
P10-70-SSCx160	Incomplete Motor Parts
P10-70-SSCx240	Incomplete Motor Parts
P10-70-SSCx320	Incomplete Motor Parts
P10-70-SSCx400	Incomplete Motor Parts
P10-70-SSCx480	Incomplete Motor Parts
P10-70-SSCx80	Incomplete Motor Parts
P10-70x160+	Incomplete Motor Parts
P10-70x240+	Incomplete Motor Parts
P10-70x320+	Incomplete Motor Parts
P10-70x400+	Incomplete Motor Parts
P10-70x480+	Incomplete Motor Parts
P10-70x80+	Incomplete Motor Parts
PS10-70-SSCx160	Incomplete Motor Parts
PS10-70-SSCx240	Incomplete Motor Parts
PS10-70-SSCx320	Incomplete Motor Parts
PS10-70-SSCx400	Incomplete Motor Parts
PS10-70-SSCx480	Incomplete Motor Parts
PS10-70-SSCx80	Incomplete Motor Parts
PS10-70x160+	Incomplete Motor Parts
PS10-70x240+	Incomplete Motor Parts
PS10-70x320+	Incomplete Motor Parts
PS10-70x400+	Incomplete Motor Parts
PS10-70x480+	Incomplete Motor Parts
PS10-70x80+	Incomplete Motor Parts

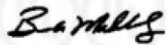

Bruce Mahrenholz, Director North American Certification Program

UL LLC

Any information and documentation involving UL Mark services are provided on behalf of UL LLC (UL) or any authorized licensee of UL. For questions, please contact a local UL Customer Service Representative at <http://ul.com/about/ullocations>



13 EU Declaration of Conformity CE-Marking

NTI AG / LinMot®
Bodenaeckerstrasse 2
8957 Spreitenbach

Switzerland

Tel.: +41 (0)56 419 91 91

Fax: +41 (0)56 419 91 92

declares under sole responsibility the compliance of the products:

- Linear Motors of the Series **PS10-70x ..-.-..**
- Linear Motors of the Series **PS10-70x ..-.-.. -D04**
- Linear Motors of the Series **PS10-70x ..-.-.. -D05**
- Linear Motors of the Series **PS10-70x ..-.-.. -D08**
- Linear Motors of the Series **PS10-70x ..-.-.. -D24**
- Linear Motors of the Series **PS10-70x ..-.-.. -D24S**
- Linear Motors of the Series **PS10-70x ..-.-.. -D25**
- Linear Motors of the Series **PS10-70x ..-.-.. -D25S**
- Linear Motors of the Series **PS10-70x ..-.-.. -D26**
- Linear Motors of the Series **PS10-70x ..-.-.. -D34**
- Linear Motors of the Series **PS10-70x ..-.-.. -G07**
- Linear Motors of the Series **PS10-70x ..-.-.. -G08**
- Linear Motors of the Series **PS10-70x ..-.-.. -S03/1**
- Linear Motors of the Series **PS10-70x ..-.-.. -S03/2**
- Linear Motors of the Series **PS10-70x ..-.-.. -S05**

(.. stands for any number of alphanumeric characters)

with the Low Voltage Directive 2014/35/EU 2014/35/EU.

Applied harmonized standards:

- **EN 61800-5-1: 2007 / A11: 2021**

with the EMC Directive 2014/30/EU.

Applied harmonized standards:

- **EN 61000-6-2: 2005 (Immunity for industrial environments)**
- **EN 61000-6-4: 2007 + A1: 2011 (Emission for industrial environments)**

According to the EMC directive, the listed devices are not independently operable products.

Compliance of the directive requires the correct installation of the product, the observance of specific installation guides and product documentation. This was tested on specific system configurations.

The safety instructions of the manuals are to be considered.

The product must be mounted and used in strict accordance with the installation instructions contained within the installation guide, a copy of which may be obtained from NTI AG.

Year of CE marking: 2021

Company: NTI AG
Spreitenbach, 11.06.2026



Dr.-Ing. Ronald Rohner
CEO NTI AG

14 UK Declaration of Conformity UKCA-Marking

NTI AG / LinMot®
Bodenaeckerstrasse 2
8957 Spreitenbach

Switzerland

Tel.: +41 (0)56 419 91 91
Fax: +41 (0)56 419 91 92

declares under sole responsibility the compliance of the products:

- Linear Motors of the Series **PS10-70x ...-...-**
- Linear Motors of the Series **PS10-70x ...-...- -D04**
- Linear Motors of the Series **PS10-70x ...-...- -D05**
- Linear Motors of the Series **PS10-70x ...-...- -D08**
- Linear Motors of the Series **PS10-70x ...-...- -D24**
- Linear Motors of the Series **PS10-70x ...-...- -D24S**
- Linear Motors of the Series **PS10-70x ...-...- -D25**
- Linear Motors of the Series **PS10-70x ...-...- -D25S**
- Linear Motors of the Series **PS10-70x ...-...- -D26**
- Linear Motors of the Series **PS10-70x ...-...- -D34**
- Linear Motors of the Series **PS10-70x ...-...- -G07**
- Linear Motors of the Series **PS10-70x ...-...- -G08**
- Linear Motors of the Series **PS10-70x ...-...- -S03/1**
- Linear Motors of the Series **PS10-70x ...-...- -S03/2**
- Linear Motors of the Series **PS10-70x ...-...- -S05**

(.. stands for any number of alphanumeric characters)

with the Electrical Equipment (Safety) Regulations 2016 SI 2016 No. 1101

Applied designated standards:

- **EN 61800-5-1: 2007 / A11: 2021**

with the EMC Regulation S.I. 2016 No. 1091.

Applied designated standards:

- **EN 61000-6-2: 2005 (Immunity for industrial environments)**
- **EN 61000-6-4: 2007 + A1: 2011 (Emission for industrial environments)**

According to the EMC regulation, the listed devices are not independently operable products.

Compliance of the regulation requires the correct installation of the product, the observance of specific installation guides and product documentation. This was tested on specific system configurations.

The safety instructions of the manuals are to be considered.

The product must be mounted and used in strict accordance with the installation instructions contained within the installation guide, a copy of which may be obtained from NTI AG.

Year of CE marking: 2021

Company: NTI AG
Spreitenbach, 11.06.2026



Dr.-Ing. Ronald Rohner
CEO NTI AG

ALL LINEAR MOTION FROM A SINGLE SOURCE

Europe / Asia Headquarters

NTI AG - LinMot & MagSpring

Bodenaeckerstrasse 2
CH-8957 Spreitenbach

Sales / Administration: T +41-(0)56-419 91 91
F +41-(0)56-419 91 92
office@linmot.com

Tech. Support: +41-(0)56-544 71 00
support@linmot.com

Web: <http://www.linmot.com/>

North / South America Headquarters

LinMot USA, Inc.

N1922 State Road 120, Unit 1
Lake Geneva, WI 53147

Sales / Administration : 262-743-2555
usasales@linmot.com

Tech. Support: usasupport@linmot.com

Web: <http://www.linmot-usa.com/>

Visit <http://www.linmot.com/> to find a distributor next to you.