

Installation Guide Force Sensor Modules

EN

DM01-23-FS / DM01-37-FS / DM01-48-FS

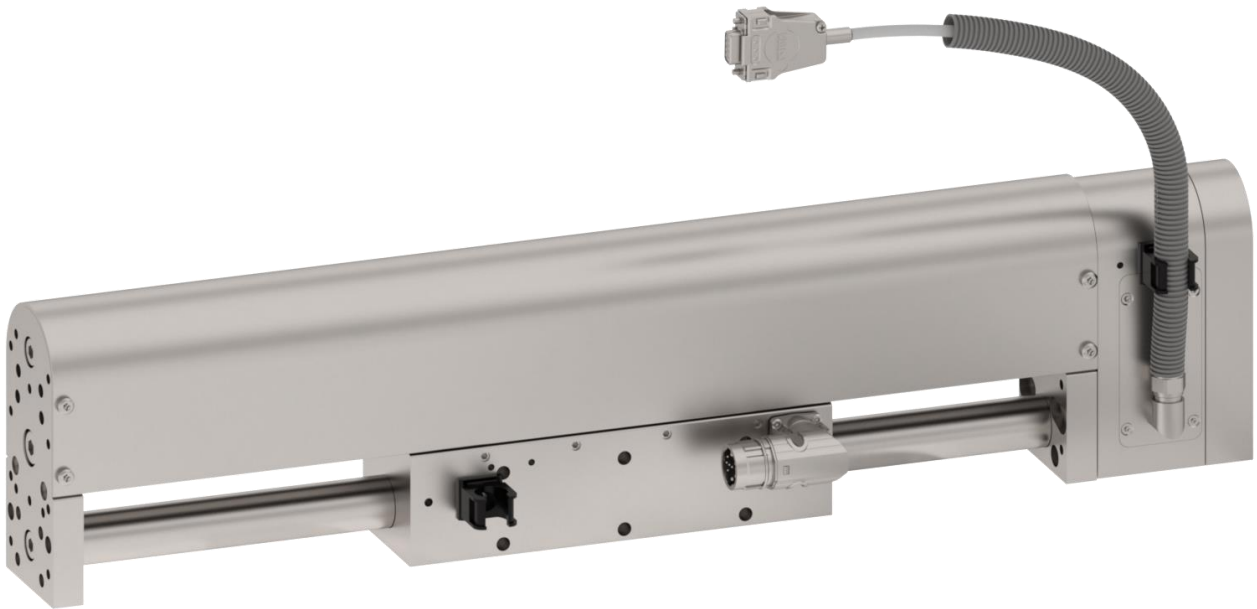

Content

1	General Information	4
1.1	Introduction	4
1.2	Explanation of Symbols	4
1.3	Qualified Personnel	4
1.4	Liability	4
1.5	Copyright	4
2	Safety Instructions	5
3	Installation Instructions	7
3.1	Operating Conditions	7
3.2	Assembling Instruction Force Sensor DM01-23-FS	7
3.3	Assembling Instruction Force Sensor DM01-37-FS	8
3.4	Assembling Instruction Force Sensor DM01-48-FS	9
3.5	Adjusting the Length of the Cable Conduit	10
3.5.1	DM01-23	10
3.5.2	DM01-37	10
3.5.3	DM01-48x150	11
3.5.4	DM01-48x240	11
3.6	Material Data	11
4	Electrical Connection	11
4.1	Sensor Cable	11
4.1.1	Technical Data	11
4.2	Pin Assignment Sensor Cable	12
4.3	Force Sensor Module Wiring	12
4.3.1	Connection to C11x0 and C12xx Servo Drives	12
4.3.2	Connection to C1252 Servo Drive	13
5	Commissioning	13
5.1	Initial Commissioning of the Force Sensor	13
5.1.1	Technology Function Force Control" Software Package	13
5.1.2	Setting the Parameters for Force Control at C12x0	13
5.1.3	Initial Testing of a Force Sensor	14
5.2	Special LinMot-Talk Functions	15
5.2.1	Tare Function	15
5.2.2	Speed limiter function	16
6	Accessories	17
6.1	Extension Cables	17
6.1.1	Extension Cable for Connection to C11x0 and C12xx Servo Drives	17
6.1.2	Extension Cable for Connection to Servo Drive C1252	17
7	Maintenance and Test Instructions	17
7.1	Maintenance	17
7.2	Cleaning	18
7.3	Lubrication	18
7.4	Calibration	18

8	Transport and storage	18
9	Dimensions	19
9.1	Force Sensor Module DM01-23-FS.....	19
9.2	Force Sensor Module DM01-37-FS.....	21
9.3	Force Sensor Module DM01-48-FS.....	22
10	EU Declaration of Conformity CE-Marking	23
11	UK Declaration of Conformity UKCA-Marking	24

1 General Information

1.1 Introduction

This manual includes instructions for the assembly, installation, maintenance, transport, and storage of DM01 force sensor modules. The document is intended for electricians, mechanics, service technicians, and warehouse staff.

Read this manual before using the product and observe the general safety instructions and those in the relevant section at all times.

Keep these operating instructions in an accessible place and make them available to the personnel assigned.

1.2 Explanation of Symbols



Triangular warning signs warn of danger.



Round command symbols tell what to do.

1.3 Qualified Personnel

All work such as installation, commissioning, operation and service of the product may only be carried out by qualified personnel.

The personnel must have the necessary qualifications for the corresponding activity and be familiar with the installation, commissioning, operation and service of the product. The manual and in particular the safety instructions must be carefully read, understood and observed.

1.4 Liability

NTI AG (as manufacturer of LinMot and MagSpring products) excludes all liability for damages and expenses caused by incorrect use of the products. This also applies to false applications, which are caused by NTI AG's own data and notes, for example in the course of sales, support or application activities. It is the responsibility of the user to check the data and information provided by NTI AG for correct applicability in terms of safety. In addition, the entire responsibility for safety-related product functionality lies exclusively with the user. Product warranties are void if products are used with stators, sliders, servo drives or cables not manufactured by NTI AG unless such use was specifically approved by NTI AG.

NTI AG's warranty is limited to repair or replacement as stated in our standard warranty policy as described in our "terms and conditions" previously supplied to the purchaser of our equipment (please request copy of same if not otherwise available). Further reference is made to our general terms and conditions.

1.5 Copyright

This work is protected by copyright.

Under the copyright laws, this publication may not be reproduced or transmitted in any form, electronic or mechanical, including photocopying, recording, microfilm, storing in an information retrieval system, not even for training purposes, or translating, in whole or in part, without the prior written consent of NTI AG.

LinMot® and MagSpring® are registered trademarks of NTI AG.

2 Safety Instructions



Contusions

Sliders contain neodymium magnets and have a strong attractive force. Careless handling could cause fingers or skin to become pinched between two sliders. This may lead to contusions, bruises, and bone fractures. When handling sliders, wear thick protective gloves and keep a minimum distance between sliders. Refer to the "Minimum distance from slider" section for minimum distance.

To reduce the risk of injury, never more than one slider should be held or transported by the same person without packaging.



Pacemaker / Implanted Heart Defibrillator

Sliders could affect the functioning of pacemakers and implanted heart defibrillators. For the duration of a strong approach to a magnetic field, these devices switch into test mode and will not function properly.

- If you wear one of those devices keep the following minimum distances between the pacemaker / defibrillator and slider:
 - Min. 250 mm (10") for slider Ø 27 mm and 28 mm (PL01-27 / 28 / PL10-28)
 - Min. 150 mm (6") for slider Ø 19 mm and 20 mm (PL01-19 / 20)
 - Min. 100 mm (4") for slider Ø 12 mm (PL01-12)
- Inform others who wear these devices to comply with these minimum distances!



Caution - Risk of Electric Shock !

Before working, make sure that there are no high voltages.



Fast-moving Machine Parts

The sliders of LinMot linear motors are fast-moving machine parts. All necessary precautions must be taken to prevent persons approaching the moving elements during operation (provide covers, guards, etc.).



Automatic Restart

The motors can start automatically under certain circumstances! If necessary, a corresponding warning symbol must be provided and protection against entering the hazardous area or a suitable safe electronic disconnection must be provided!



Risk of Injury due to a Defect or Fault

For areas where a defect or fault can result in substantial property damage or even serious personal injury, additional external precautions must be taken or devices must be installed to ensure safe operation even if a defect or fault occurs (eg. suitable safe electronic disconnection, mechanical interlocks, barriers, etc.).



Magnetic Field

Magnets integrated in the sliders produce a strong magnetic field. They could damage TVs, laptops, computer hard drives, credit and ATM cards, data storage media, mechanical watches, hearing aids, and speakers.

- Keep magnets away from devices and objects that could be damaged by strong magnetic fields.
- For the above mentioned objects, keep a minimum distance as described in the "Pacemaker / implanted defibrillator" section.
- For non-anti-magnetic watches, keep the double minimum distance.

**Combustibility**

When machining magnets, the drilling dust could easily ignite. Machining the sliders and the magnets they contain is not permitted.

**Burn Hazard**

During operation the slider can become hotter than 100 °C, which can cause burns if touched. All necessary precautions (e.g. covers, casing, etc.) must be taken to prevent contact with persons in the vicinity of the slider during operation.

**Grounding**

All metal parts that are exposed to contact during any user operation or servicing and likely to become energized shall be reliably connected to the means for grounding.

**Mechanical Handling**

Neodymium magnets are brittle and heat-sensitive. Machining the sliders and the magnets they contain is not permitted.

- Colliding magnets could crack. Sharp splinters could be catapulted for several meters and cause eye injury.
- By machining the sliders, heat would result which demagnetizes the magnets.

**Slider**

Linear motor sliders consist of a high-precision, thin-walled stainless steel tube in which the neodymium magnets are housed. The LinMot sliders should be handled with care. Avoid contact with other sliders or iron parts as this can damage the magnets and the slider surface. Do not grip the sliders with pliers, as this can also damage the surface. Do not use sliders which are already damaged on the surface (scratches, deformation, etc.). This can cause further damage to the stator.

**Effects on People**

According to the current level of knowledge, magnetic fields of permanent magnets do not have a measurable positive or negative effect on people. It is unlikely that permanent magnets constitute a health risk, but it cannot be ruled out entirely.

- For your own safety, avoid constant contact with magnets.
- Store large magnets at least one meter away from your body.

**Temperature Resistance**

Keep slider away from unshielded flame or heat. Temperature above 120°C will cause demagnetization.

3 Installation Instructions

3.1 Operating Conditions



- The ambient temperature limit is: 0 °C...80 °C (reduced accuracy)
- The nominal service temperature is: 5 °C...45 °C
- Max. Installation altitude: The maximum installation altitude is 4,000 m a.s.l. Above 1,000 m, a derating of 1 °C per 100 m must be taken into account for air cooling.

3.2 Assembling Instruction Force Sensor DM01-23-FS



Be sure to observe the safety instructions in chapter 2 during assembly!

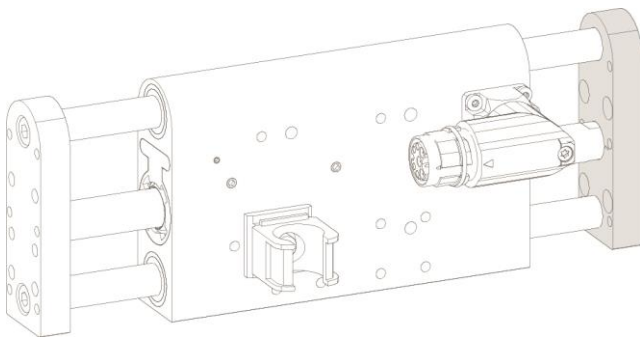

1. Set mounting side

The force sensor module can be mounted on either side of the linear module.



Due to the mechanical connection of the slider, it is recommended to mount the force sensor on the connector side of the linear module. On this side, the force is applied directly via a fixed bearing.

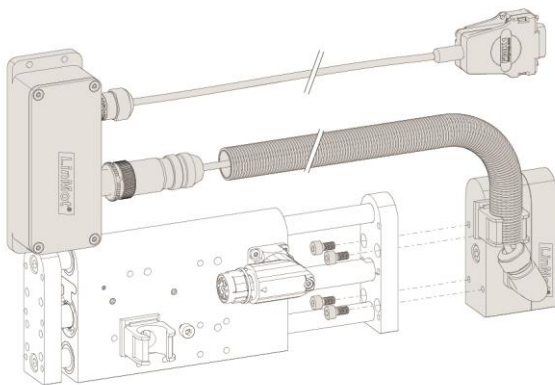

2. Mount force sensor module

Apply Loctite 243 threadlocker to the threaded holes of the force sensor module. Then fix the module to the front plate of the linear module with the four screws.

Tightening torque: 2.6 Nm

The measuring amplifier box can be placed externally in the machine. The IP protection class of the amplifier is IP63.

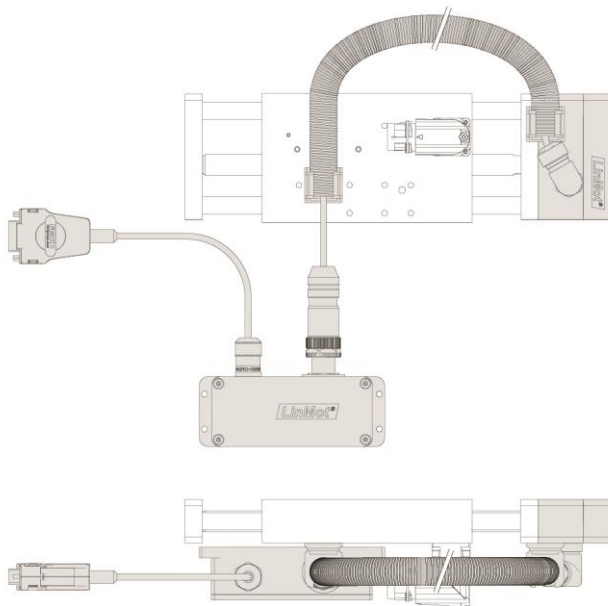

3. Wiring the force sensor module

The sensor cable is guided in a cable conduit. The cable conduit can be shortened as required (see chapter 3.5). For mounting, 2 brackets are supplied which can be mounted on the DM01 linear module (see illustration). A drive-side open-end extension cable is recommended for connecting the force sensor module to servo drives of the C11x0 and C12xx series (see chapter Accessories). The wiring diagram is shown in chapter 4.3.



Only connect or disconnect the sensor cable when there is no voltage at the servo drive!

3.3 Assembling Instruction Force Sensor DM01-37-FS



Be sure to observe the safety instructions in chapter 2 during assembly!

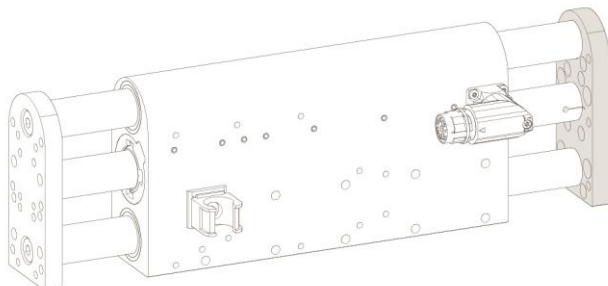

1. Set mounting side

The force sensor module can be mounted on either side of the linear module.



Due to the mechanical connection of the slider, it is recommended to mount the force sensor on the connector side of the linear module. On this side, the force is applied directly via a fixed bearing.

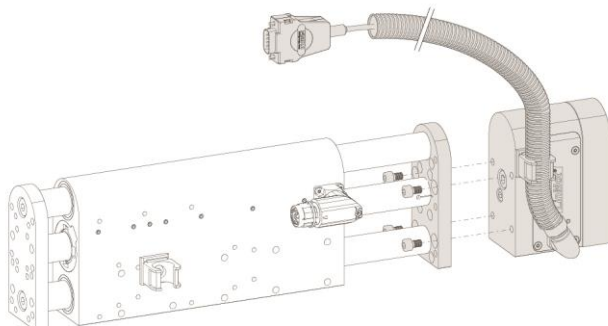

2. Mount force sensor module

Apply Loctite 243 threadlocker to the threaded holes of the force sensor module. Then fix the module to the front plate of the linear module with the four screws.

Tightening torque: 8.6 Nm

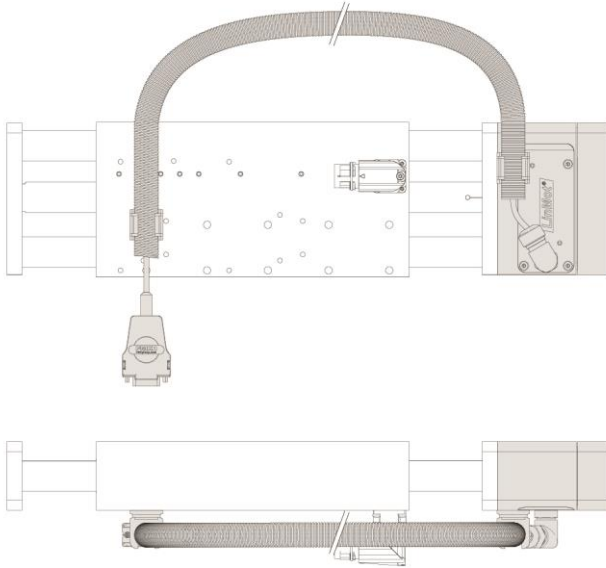

3. Wiring the force sensor module

The sensor cable is guided in a cable conduit. The cable conduit can be shortened as required (see chapter 3.5). For mounting, 2 brackets are supplied which can be mounted on the DM01 linear module (see illustration). A drive-side open-end extension cable is recommended for connecting the force sensor module to servo drives of the C11x0 and C12xx series (see chapter Accessories). The wiring diagram is shown in chapter 4.3.



Only connect or disconnect the sensor cable when there is no voltage at the servo drive!

3.4 Assembling Instruction Force Sensor DM01-48-FS



Be sure to observe the safety instructions in chapter 2 during assembly!

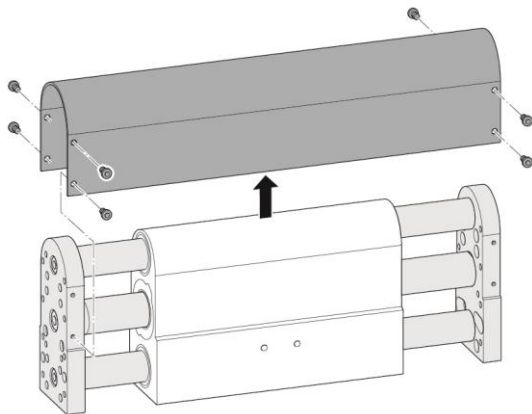

1. Dismantle cover

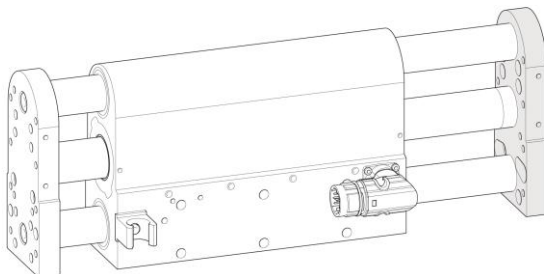

2. Set mounting side

The force sensor module can be mounted on either side of the linear module.



Due to the mechanical connection of the slider, it is recommended to mount the force sensor on the connector side of the linear module. On this side, the force is applied directly via a fixed bearing.

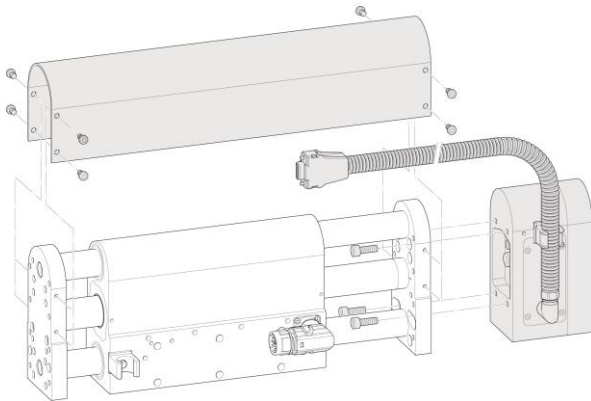

3. Mount force sensor module

Apply Loctite 243 threadlocker to the threaded holes of the force sensor module. Then fix the module to the front plate of the linear module with the four screws.

Tightening torque: 8.6 Nm

Finally, refit the cover.

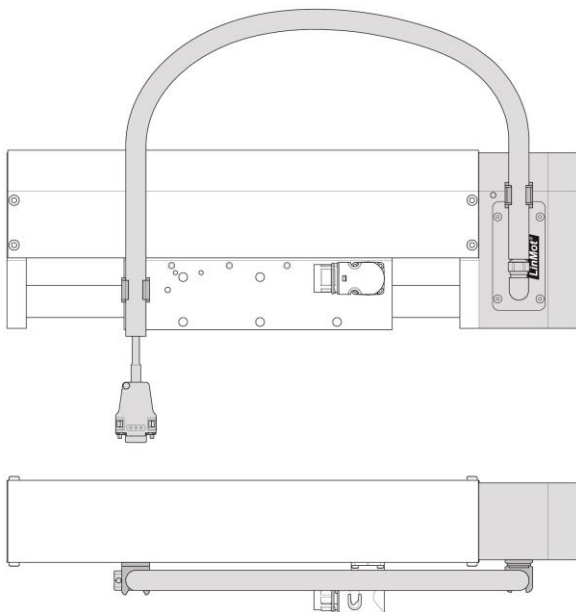

4. Wiring the force sensor module

The sensor cable is guided in a cable conduit. The cable conduit can be shortened as required (see chapter 3.5). For mounting, 2 brackets are supplied which can be mounted on the DM01 linear module (see illustration). A drive-side open-end extension cable is recommended for connecting the force sensor module to servo drives of the C11x0 and C12xx series (see chapter Accessories). The wiring diagram is shown in chapter 4.3.



Only connect or disconnect the sensor cable when there is no voltage at the servo drive!

3.5 Adjusting the Length of the Cable Conduit

All force sensors are delivered with a ready-mounted cable conduit. It is recommended that this is shortened to an appropriate length. This length is based on the stroke and is measured from the beginning of bracket 1 to the end of bracket 2.

3.5.1 DM01-23

Stroke [mm]	60	100	160	220	290	350
Recommended length of the cable conduit [mm]	385	415	475	535	605	665

3.5.2 DM01-37

Stroke [mm]	95	195	295	395	495	595
Recommended length of the cable conduit [mm]	505	605	705	805	905	1005

3.5.3 DM01-48x150

Stroke [mm]	95	125	185	275	305	395	485	575
Recommended length of the cable conduit [mm]	475	505	565	655	685	775	865	955

3.5.4 DM01-48x240

Stroke [mm]	95	185	305	395	485
Recommended length of the cable conduit [mm]	565	595	655	865	955

3.6 Material Data

Component	Material
Housing	Anodised aluminium
Front plate	Anodised aluminium
Seal	NBR 70
Cable connector	Brass nickel plated
Sensor cable (sheath)	PUR
Cable conduit	Polyamide

4 Electrical Connection

4.1 Sensor Cable



Only connect or disconnect the sensor cable when there is no voltage at the servo drive! Use original LinMot cables for sensor wiring! Self-assembled cables must be checked carefully before commissioning! Incorrect sensor wiring can damage the sensor and / or the servo drive!

The force sensor has a direct cable outlet of 2 m length. Depending on the drive family, the force sensor can be connected directly to the servo drive or extended if required. Extension cables are listed in the "Accessories" chapter.

4.1.1 Technical Data

	High-Flex Cable
Cable name	KS14-06
Minimum bending radius for fixed installation	18 mm
Minimum bending radius when moving	50 mm (2 in) No torsion
Shielding	simply
Length	2m
Approval	UL/CSA
Material wire insulation	TPE
Material cable sheath	PUR
Oil resistance	very good according to EN 50363-10-2 + VDE 0207-363-10-2
Chemical resistance (to acids, alkalis, solvents, hydraulic fluid)	good
Burning behaviour	Flame retardant and self-extinguishing

4.2 Pin Assignment Sensor Cable



Only connect or disconnect the sensor cable when there is no voltage at the servo drive! Use original LinMot cables for sensor wiring! Self-assembled cables must be checked carefully before commissioning! Incorrect sensor wiring can damage the sensor and / or the servo drive!

Pin assignment	Force sensor PIN	Core colour Sensor cable
Supply GND	1	white
Do not connect	2	n/a
AGND	3	pink
Do not connect	4	n/a
Force+	5	grey
Supply 24V	6	brown
Do not connect	7	n/a
Motlink P	8	green
Force-	9	yellow
Connector housing	Shield	n/a
Connector scheme (Cable outlet)		



PIN 9 (power -) and PIN 1 (supply ground) are internally galvanically isolated and must not be connected to each other.

4.3 Force Sensor Module Wiring

The type of connection between the force sensor and the servo drive depends on the LinMot servo drive.

4.3.1 Connection to C11x0 and C12xx Servo Drives

The following diagram shows the connection of the force sensor to terminal **X4 LOGIC SUPPLY CONTROL** of the LinMot servo drive.

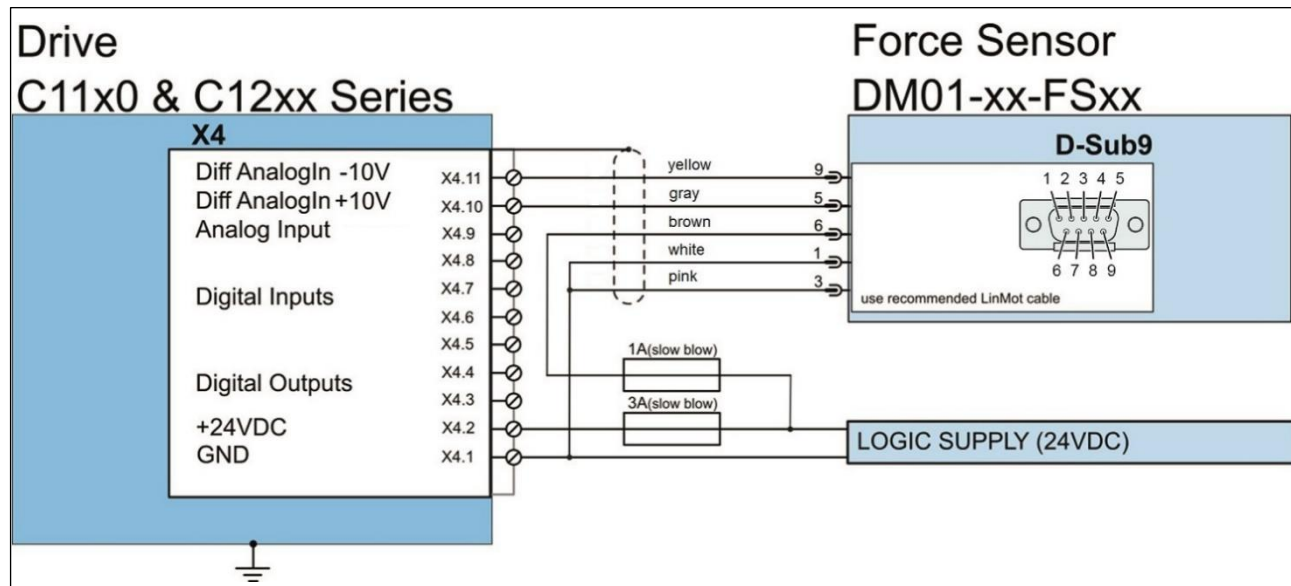

4.3.2 Connection to C1252 Servo Drive

The DSUB connector of the force sensor can be connected directly to the C1252 Drive via the **X3 MOT SENSOR** interface.

5 Commissioning

5.1 Initial Commissioning of the Force Sensor



An optionally mounted force sensor is a high-precision measuring device and must be handled accordingly. Incorrect handling, e.g. driving in to the mechanical stop, will cause collisions that may exceed the maximum force defined in the data sheet. Incorrect handling of the measuring device can damage the sensors.

It is strongly recommended to carefully follow the initial commissioning steps and test the correct functioning of the measuring device before using it in real application.

5.1.1 Technology Function Force Control" Software Package

If a closed control loop is to be implemented via a sensor (force control of a motor by means of sensor feedback to the LinMot Drive), it is mandatory to order the "TF Force Control" software package (art. no.: 0150-2503).

Without this software package, it is not possible to control a specific force or to use the drive commands of the "TF Force Control" software package.

If only the signal of the force sensor is evaluated (PLC or LinMot Drive), the software package can be dispensed with.

5.1.2 Setting the Parameters for Force Control at C12x0

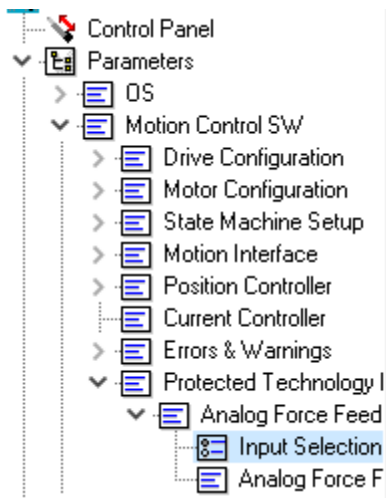

Logged into the drive, you will find all the parameters to be set in the LinMot-Talk software under the path "Parameters -> Motion Control SW -> Protected Technology Functions -> Analogue Force Feedback Control".

Parameter Tree: Input Selection

Please select the following setting under "Input Selection":

- Input Selection (UPID 150Fh) = Diff Analog Input On X4.10/X4.11

Name	Value	Raw Data	Value...	UPID
<input type="radio"/> None	Off	0004h	***	150Fh
<input type="radio"/> Analog Input On X4.9	Off	0001h	***	150Fh
<input checked="" type="radio"/> Diff Analog Input On X4.10/X4.11	On	0002h	***	150Fh

Parameter Tree: Analogue Force Feedback Config



Due to the definition of the DEFAULT positive direction of the stroke, it is recommended to invert the +-10VDC signal via software. This means that for the parameter "0V/-10V Force" the positive maximum value and for the parameter "+10V Force" the negative maximum value of the force sensor is set. By changing the direction of the stroke, the setting of the parameters "0V/-10V force" and "+10V force" must also be changed.

- 0V/-10V Force (UPID 1501h) = Positive maximum value (e.g. 500 N)
- 10V Force (UPID 1502h) = Negative maximum value (e.g. -500 N)
- Speed Filter Time (UPID 150Ah) = 1000µs
- Acceleration Filter Time (UPID 150Dh) = 1000µs

Name	Value	Raw Data	Value...	UPID	Type	Scale	Offset	Min	Max	Def...	Attr.
0V/-10V Force	500 N	1388h	500 N	1501h	SInt16	0.1 N	0 N	-3276.8 N	3276.7 N	0 N	RW
10V Force	-500 N	EC78h	-500 N	1502h	SInt16	0.1 N	0 N	-3276.8 N	3276.7 N	10...	RW
Speed Filter Time	1000 us	03E8h	1000 ...	150Ah	UInt16	1 us	0 us	0 us	65535 us	10...	RW
Acceleration Filter Time	1000 us	03E8h	1000 ...	150Dh	UInt16	1 us	0 us	0 us	65535 us	10...	RW

Parameter Tree: Force Control Parameters

The parameters for the force control loop are set here. A PID controller, a few pre-control parameters (FF parameters) and a parameter for limiting the maximum control current (Force Ctrl Max Current) are available for this purpose.



Work with a pure I controller at the beginning to prevent the motor from oscillating during torque control. Limit the maximum control current in order to avoid any possible damages during commissioning.

5.1.3 Initial Testing of a Force Sensor

It is recommended to perform an initial test of a sensor with the LinMot talk variables before reaching the operating state.

1. Log in to the Drive with the LinMot Talk software and open the "control panel".
2. Switch on the motor with the "Control Word" (Switch On). The motor remains in position control mode.
3. Add the variables "Target Force" and "Measured Force" (MC SW Force Control) via the "Add Variable" button.

The screenshot shows the LinMot software interface with several panels. The 'Control' panel on the left lists various parameters like 'Switch On', 'Jog Move', and 'Clearance Check'. The 'Status' panel in the center shows 'Operation Enabled' and 'Status Word: 0930h'. The 'Monitoring' panel on the right displays 'Motor Status: Switched Off' and 'Op. State: Ready to Switch On'. At the bottom, the 'Motion Command Interface' panel is active, showing 'Enable Manual Override' buttons and a table for adding variables. A green arrow points to the 'Add Variable' button, which is highlighted with a green box. The table below it has columns for Name, Offs., Description, Scaled Value, Init. Value (Dec), and Init. Value (Hex).

Name	Offs.	Description	Scaled Value	Init. Value (Dec)	Init. Value (Hex)
Header	0	000h: No Operation	0	0	0000h

4. Now gently push or pull the linear axis. The variable "measured force" should rise or fall according to the variable "Motor Current".

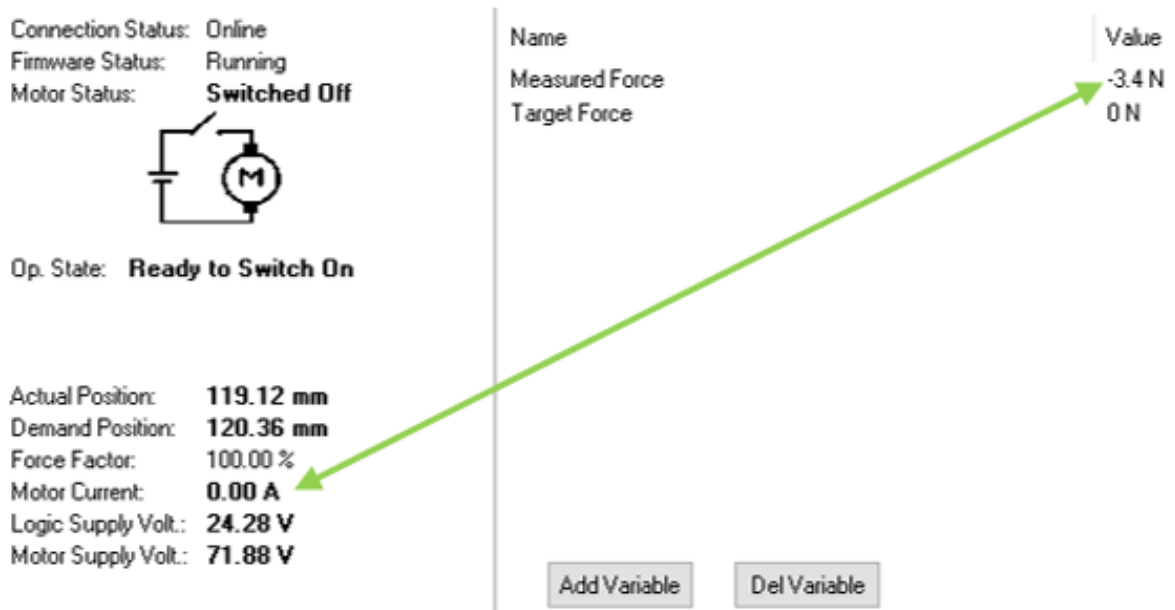

- If no change can be detected within the Measured Force variable, check the wiring of the sensor.
 - If the value of the variable "Measured Force" changes in a different direction than the variable "Motor Current" shows, please check the wiring or the parameter setting "Analog Force Feedback Setting".
- DO NOT SWITCH TO FORCE CONTROL MODE!**



When controlling hard objects (e.g. metal), impulses occur on impact which can cause lasting damage to the sensor. It is recommended to reduced speed or insert a damping insert between the sensor and the object to be pressed. Impulse measurements should be avoided if possible.

5.2 Special LinMot-Talk Functions

5.2.1 Tare Function

By means of the tare function, undesirable measuring influences during movement, e.g. sliding friction, can be eliminated. At standstill, it is used to zero the offset, e.g. caused by a vertical load mass.



In sensitive measuring applications, the cyclical use of the tare function is recommended. In this way, changes in the friction or in the mechanics are continuously detected or calculated out of the actual measurement. Changes can occur due to temperature influences, for example.

The tare function is triggered by a special move command (for details see Motion Control Manual 0150-1093-E). It records the measured force (UPID 0x1EA1) during the maximum, constant speed and automatically saves its average value as an offset (UPID 0x1798). The subsequently determined force of the sensor is thus cleansed of influences and enables more accurate measurement results.

The function allows you to define the capture time for averaging and to delay the start time of the measurement (time delay). This allows undesired erroneous measurements, e.g. caused by the acceleration of the motor, to be faded out.

5.2.2 Speed limiter function

The speed limiter function limits the maximum speed in closed-loop force and torque control as well as in current command mode. This function can prevent uncontrolled acceleration of the motor in the event of incorrect manipulation or a sudden drop in the feedback or measurement signal in the closed control loop, thus preventing mechanical damage and injuries.



- If the speed limiter function is deactivated, the motor can accelerate uncontrolled in force, torque and current control mode until the feedback or measurement signal is equal to the specified setpoint.
- To minimise mechanical damage as well as the risk of injury, the use of the speed limiter is recommended.

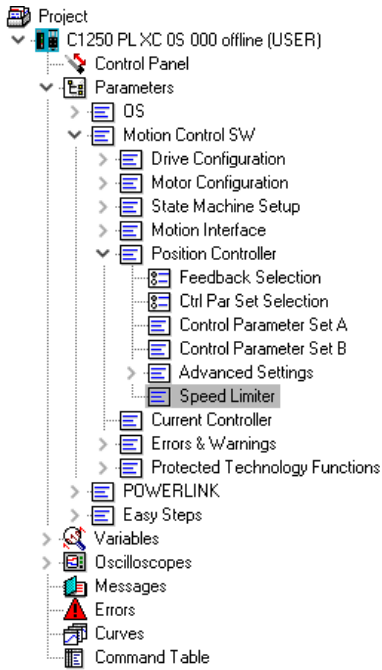

The maximum speed for force, torque and current control is defined under the "Speed Limiter" tab. If the parameterised speed "Speed Limit" is exceeded, the drive automatically switches to position control and regulates the current speed to the defined value. The "Speed Limiter Abort Force" parameter defines the measured value below which the drive switches back to force, torque or current control. If the "Speed Limit" parameter is set to 0 m/s, the function is deactivated.

Name	Value	Raw Data	Value...	UPID	Type	Scale	Offset	Min	Max	Def..	Attr.
Speed Limit	0 m/s	00000000h	*** m/s	1511h	SInt32	1E-6 m/s	0 m/s	0 m/s	2147.48364...	0 m...	RW
Speed Limiter Abort Force	0 N	0000h	*** N	1513h	UInt16	0.1 N	0 N	0 N	3276.7 N	0 N	RW

6 Accessories

6.1 Extension Cables

The length of the sensor cable of the force sensor module is 2 m. If this length is not sufficient, LinMot offers extension cables that can be ordered to custom length.

6.1.1 Extension Cable for Connection to C11x0 and C12xx Servo Drives



High-Flex cable

Item	Description	Item-No.
Special cable KSS014-06-./D	Sensor extension cable for DM01-FSxx, drive side open end	0150-5359

6.1.2 Extension Cable for Connection to Servo Drive C1252



High-Flex cable

Item	Description	Item-No.
Special cable KSS014-06-Df/Dm-	Sensor extension cable for DM01-FSxx, with Motlink	0150-6016

7 Maintenance and Test Instructions

7.1 Maintenance

No maintenance intervals are specified for the force sensors of the DM modules, as they are practically wear-free. However, the sensor should be cleaned regularly and a visual inspection of the seal should be carried out if one of the following points applies:

- Permanent pollution
- Direct sunlight
- Low humidity
- Outdoor operation
- Strong shocks or vibrations

- Increased operating temperature

Maintenance may only be carried out by LinMot or a company qualified by LinMot. The following activities are carried out during the maintenance offered below:

- Replacement of all seals
- Replacement of the cable outlet (trailing chain cable) and the cable conduit.
The cable is returned in its original configuration after maintenance and the cable conduit is cut to the length shortened by the customer. Special customer connectors are also returned.
- Recalibration

Ordering information

	Description	Item-No.
Maintenance Force Sensor DM01-XX-FS	Replacing the O-ring and trailing chain cable, lubricating the recirculating ball bearings and cleaning the sensor interior	0150-5380

7.2 Cleaning

It is not necessary to disassemble the sensor module for cleaning. If necessary, a soft cloth and alcohol can be used to clean the surface and the gap between the primary and secondary sides of the sensor module.



Sensor modules cannot be dismantled without invalidating the calibration certificate.

7.3 Lubrication

The guide elements integrated in the sensor module are provided with initial lubrication and do not need to be relubricated.

7.4 Calibration

The force sensors are supplied with a factory calibration certificate (valid for 2 years). After initial commissioning, it is recommended to have the sensors calibrated annually by LinMot.

Cyclical recalibration is a recommendation for applications in normal operation. Depending on customer requirements and applications, this cycle should be adapted.



- Recalibration is also recommended if the zero point of the sensor changes for no apparent reason.
- Recalibration is strongly recommended after improper handling. This also applies after the occurrence of a strong mechanical load (e.g. impact).
- If the sensor housing is opened, the validity of the calibration expires.

Ordering information

Item	Description	Item-No.
Calibration Force Sensor DM01-XX-FS	Factory calibration of force sensor DM01-XX-FS	0150-5381

8 Transport and storage

- LinMot force sensor modules may only be transported and stored in their original packaging.
- The force sensor modules should only be removed from the packaging during installation.
- The storage room must be dry, dust-free, frost-free and vibration-free.
- The relative humidity should be less than 60 %.
- Prescribed storage temperature: -15 °C...70 °C
- The force sensor module must be protected from extreme weather conditions.
- The room air must not contain any aggressive gases.

9 Dimensions

9.1 Force Sensor Module DM01-23-FS

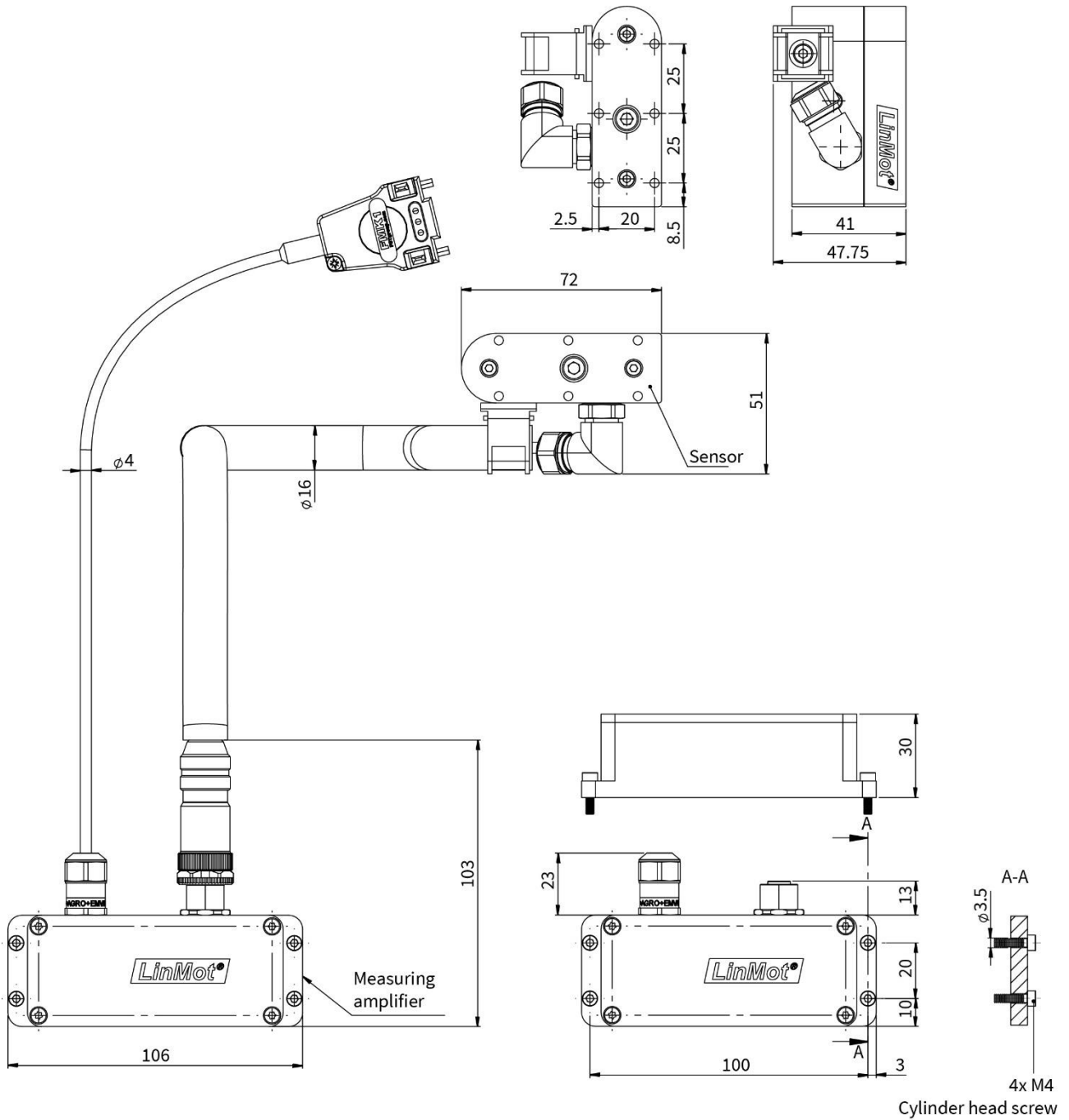

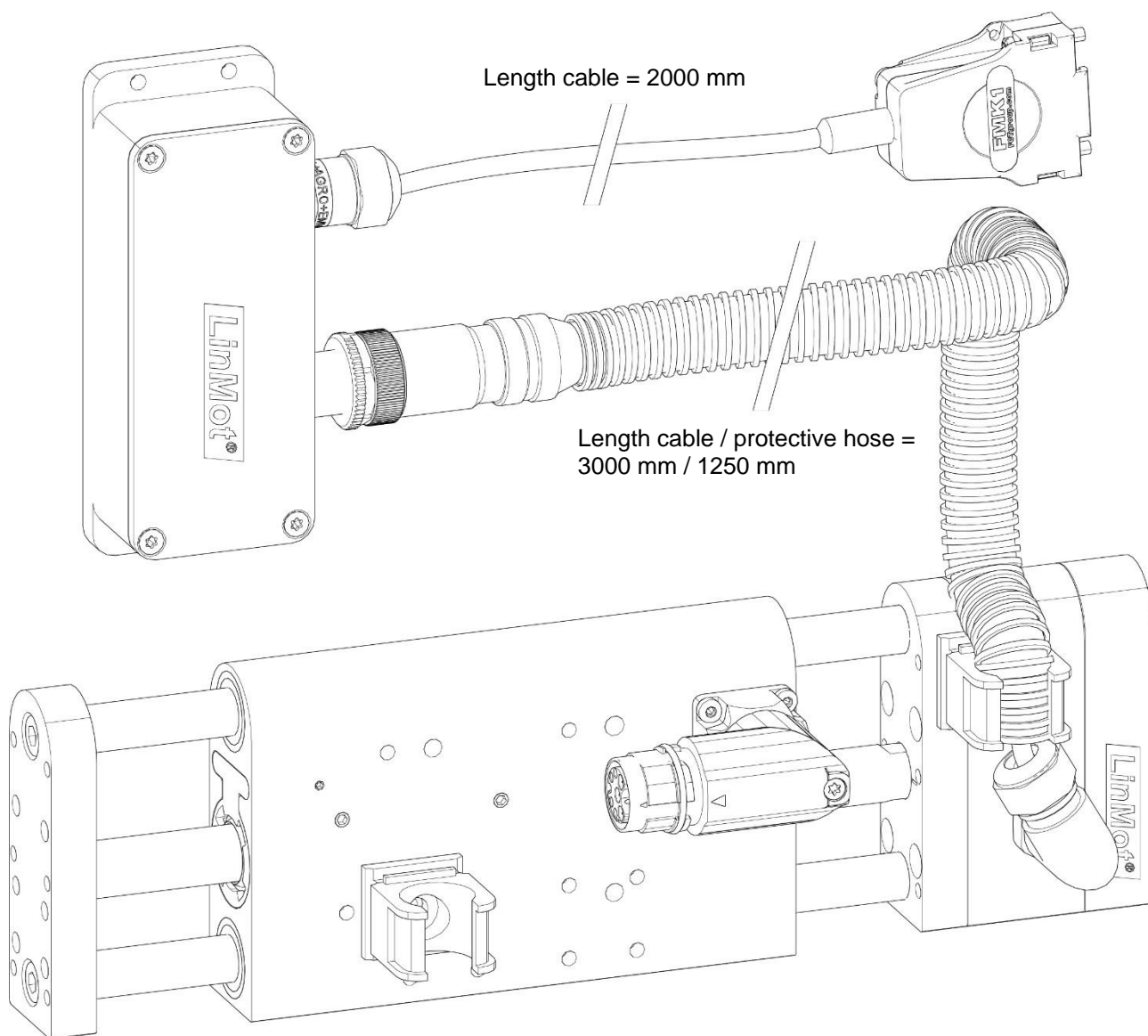

mm

9.2 Force Sensor Module DM01-37-FS

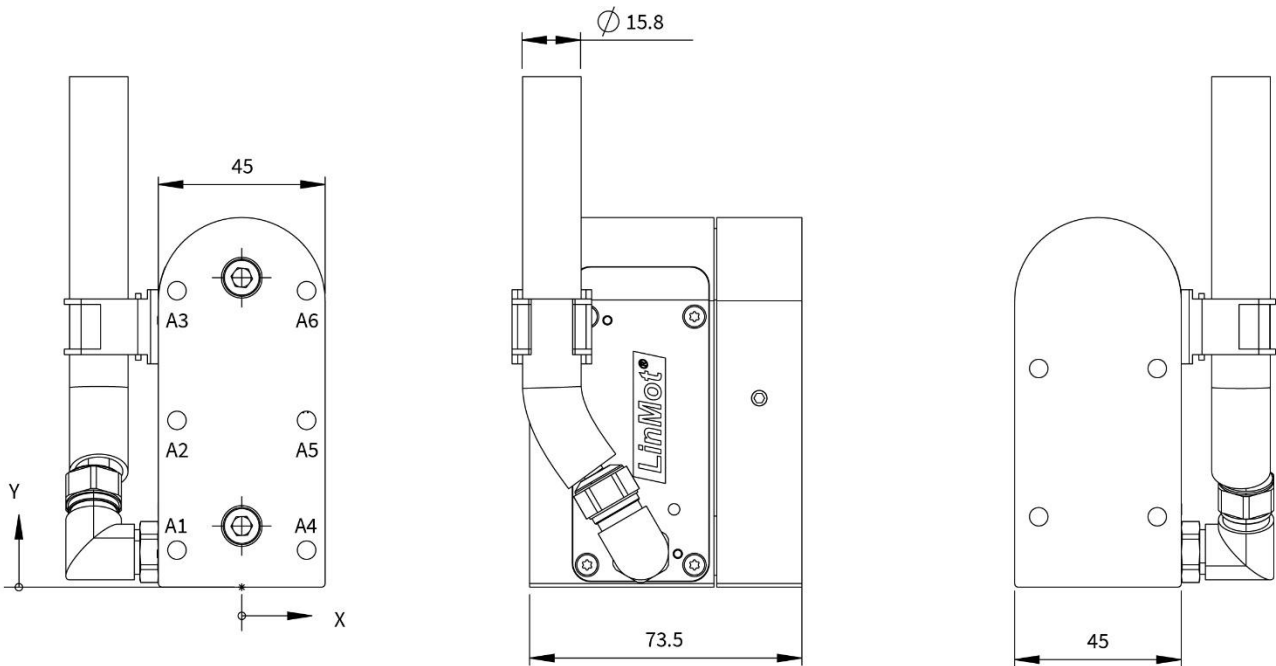

	X-POS.	Y-POS.	
A1	-17.5	10	M6 ↓ 9
A2	-17.5	45	
A3	-17.5	80	
A4	17.5	10	
A5	17.5	45	
A6	17.5	80	

Length cable / protective hose = 2000 mm / 1250 mm

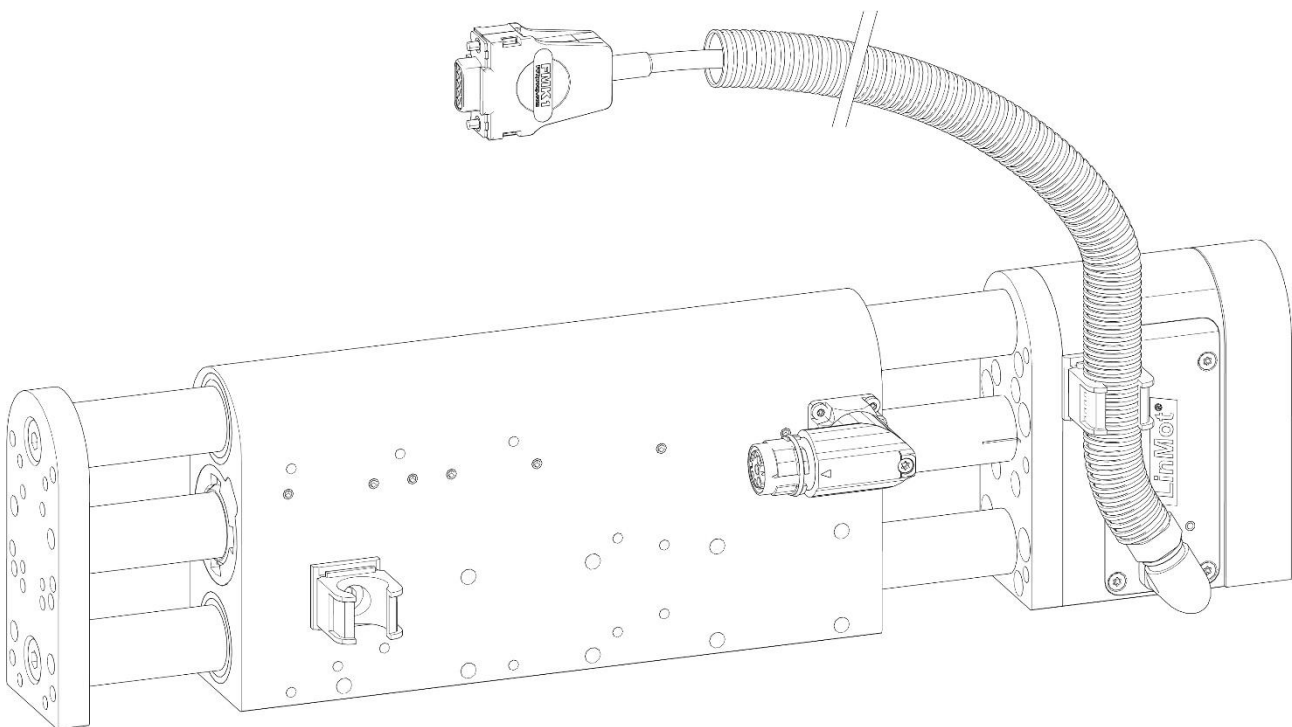

mm

9.3 Force Sensor Module DM01-48-FS

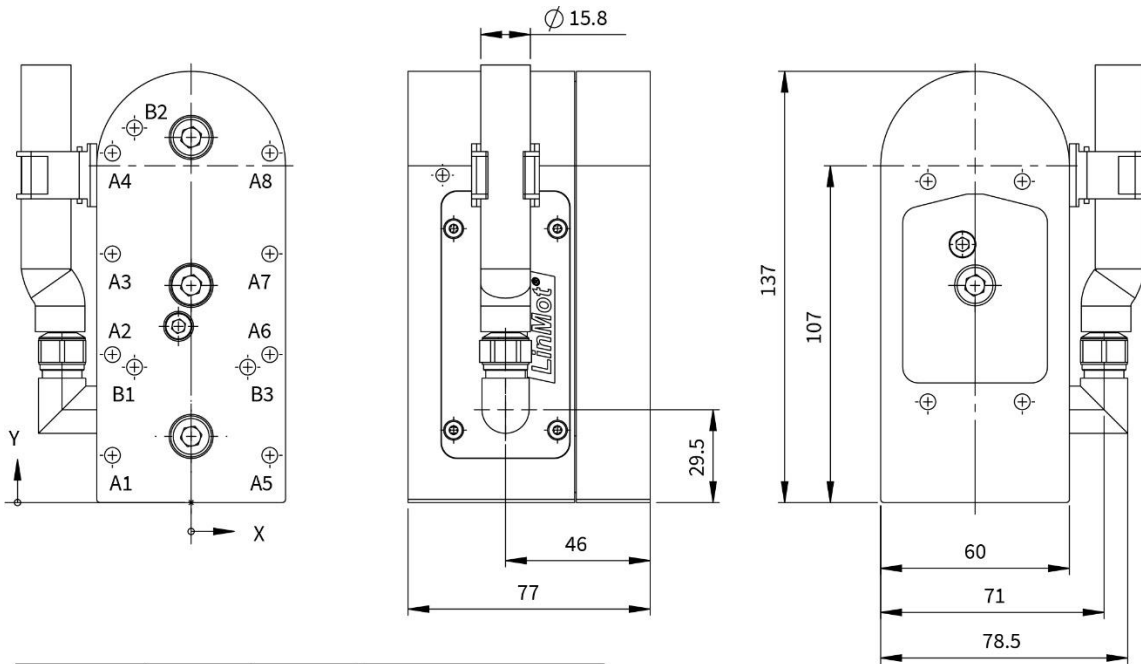

	X-POS.	Y-POS.	
A1	-25	15	$\varnothing 5 \downarrow 13$ M6-6H $\downarrow 10$
A2	-25	47	
A3	-25	79	
A4	-25	111	
A5	25	15	
A6	25	47	
A7	25	79	
A8	25	111	
B1	-18	43	$\varnothing 5 H7$ $+0.012$ 0 $\downarrow 10$
B2	-18	119	
B3	18	43	

Length cable / protective hose = 2000 mm / 1250 mm

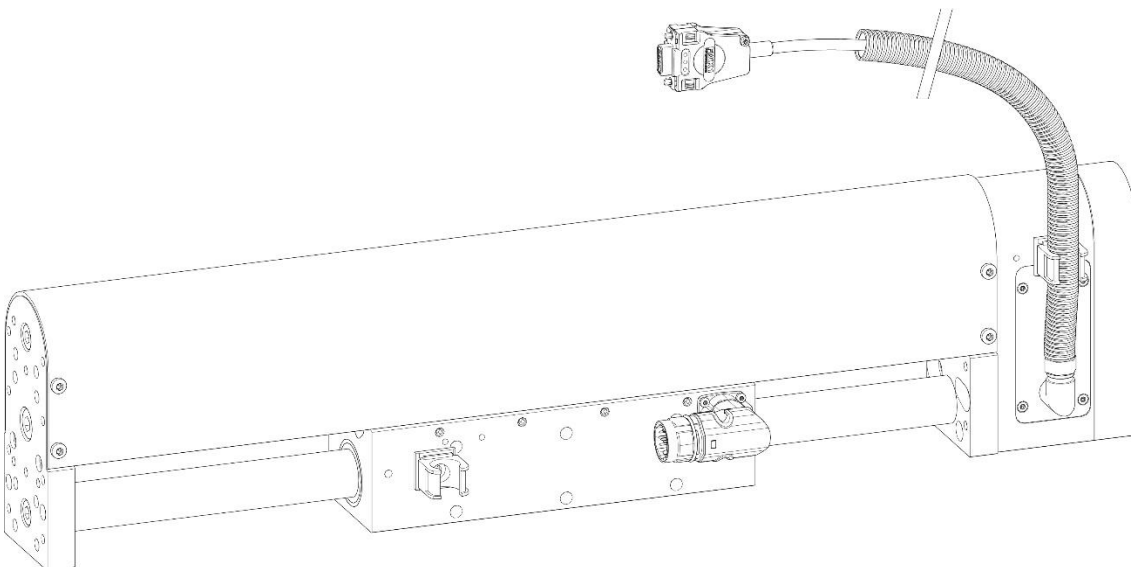

mm

10 EU Declaration of Conformity CE-Marking

NTI AG / LinMot®
Bodenaeckerstrasse 2
8957 Spreitenbach

Switzerland

Tel.: +41 (0)56 419 91 91
Fax: +41 (0)56 419 91 92

declares under sole responsibility the compliance of the products:

Product	Item-No.
DM01-37-FS21	0150-5237
DM01-37-FS22	0150-4797
DM01-48-FS22	0150-5680
DM01-48-FS25	0150-4799
DM01-23-FS23-SL01	0150-5356
DM01-37-FS21-SL01	0150-6120
DM01-37-FS22-SL01	0150-6121
DM01-48-FS22-SL01	0150-6122
DM01-48-FS25-SL01	0150-6125

with the EMC Directive 2014/30/EU.

Applied harmonized standards:

- **EN 61000-6-2: 2005 (Immunity for industrial environments)**
- **EN 61000-6-4: 2007 + A1: 2011 (Emission for industrial environments)**

According to the EMC directive, the listed devices are not independently operable products.

Compliance of the directive requires the correct installation of the product, the observance of specific installation guides and product documentation. This was tested on specific system configurations.

The safety instructions of the manuals are to be considered.

The product must be mounted and used in strict accordance with the installation instructions contained within the installation guide, a copy of which may be obtained from NTI AG.

Company: NTI AG
Spreitenbach, 20.12.2023



Dr.-Ing. Ronald Rohner
CEO NTI AG

11 UK Declaration of Conformity UKCA-Marking

NTI AG / LinMot®
Bodenaeckerstrasse 2
8957 Spreitenbach

Switzerland

Tel.: +41 (0)56 419 91 91
Fax: +41 (0)56 419 91 92

declares under sole responsibility the compliance of the products:

Product	Item-No.
DM01-37-FS21	0150-5237
DM01-37-FS22	0150-4797
DM01-48-FS22	0150-5680
DM01-48-FS25	0150-4799
DM01-23-FS23-SL01	0150-5356
DM01-37-FS21-SL01	0150-6120
DM01-37-FS22-SL01	0150-6121
DM01-48-FS22-SL01	0150-6122
DM01-48-FS25-SL01	0150-6125

with the EMC Regulation S.I. 2016 No. 1091.

Applied designated standards:

- **EN 61000-6-2: 2005 (Immunity for industrial environments)**
- **EN 61000-6-4: 2007 + A1: 2011 (Emission for industrial environments)**

According to the EMC regulation, the listed devices are not independently operable products.

Compliance of the regulation requires the correct installation of the product, the observance of specific installation guides and product documentation. This was tested on specific system configurations.

The safety instructions of the manuals are to be considered.

The product must be mounted and used in strict accordance with the installation instructions contained within the installation guide, a copy of which may be obtained from NTI AG.

Company: NTI AG
Spreitenbach, 20.12.2023



Dr.-Ing. Ronald Rohner
CEO NTI AG

ALL LINEAR MOTION FROM A SINGLE SOURCE

Europe / Asia Headquarters

NTI AG - LinMot & MagSpring

Bodenaeckerstrasse 2
CH-8957 Spreitenbach
Switzerland

Sales / Administration: +41 56 419 91 91
office@linmot.com

Tech. Support: +41 56 544 71 00
support@linmot.com

Web: <https://www.linmot.com/>

Visit <https://linmot.com/contact/> to find a distributor near you.

North / South America Headquarters

LinMot USA Inc.

N1922 State Road 120, Unit 1
Lake Geneva, WI 53147
USA

Sales / Administration: 262.743.2555
usasales@linmot.com

Tech. Support: 262.743.2555
usasupport@linmot.com

Web: <https://www.linmot-usa.com/>