

FORCE SENSOR MODULES

DM01-23-FS / DM01-37-FS / DM01-48-FS

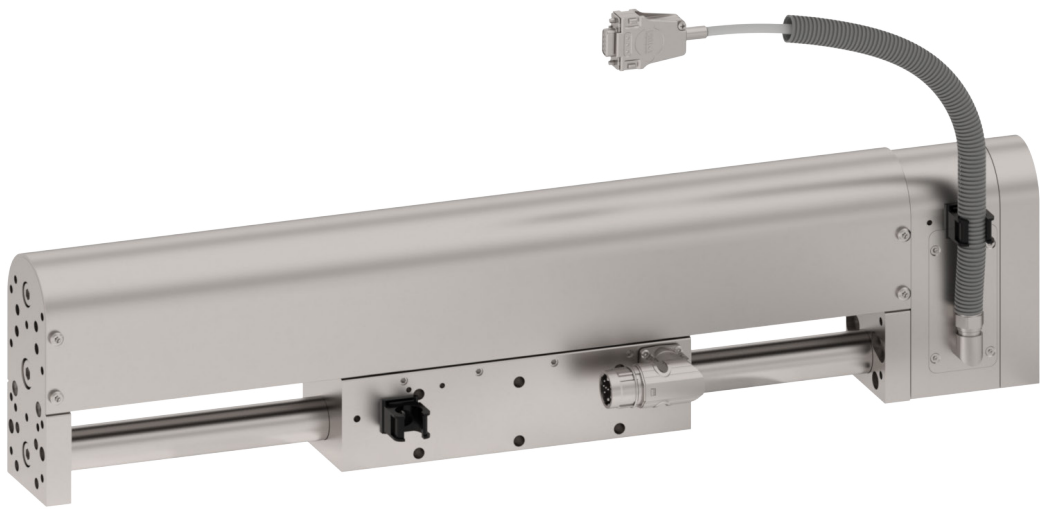

- ✓ Front flange with force sensor for direct mounting on DM01 modules
- ✓ Realization of force-controlled applications such as joining or pressing
- ✓ Implementation of process controls based on force profiles
- ✓ Decoupled force measurement in the direction of movement independent of the force application point
- ✓ Arbitrary mounting of grippers or tools without measurement influence
- ✓ High measuring accuracy with simultaneous high overload resistance

FORCE SENSOR MODULES DM01-23-FS / DM01-37-FS / DM01-48-FS

Description	_____	3
Technical Data	_____	5
Dimensions	_____	8
Ordering Information	_____	12

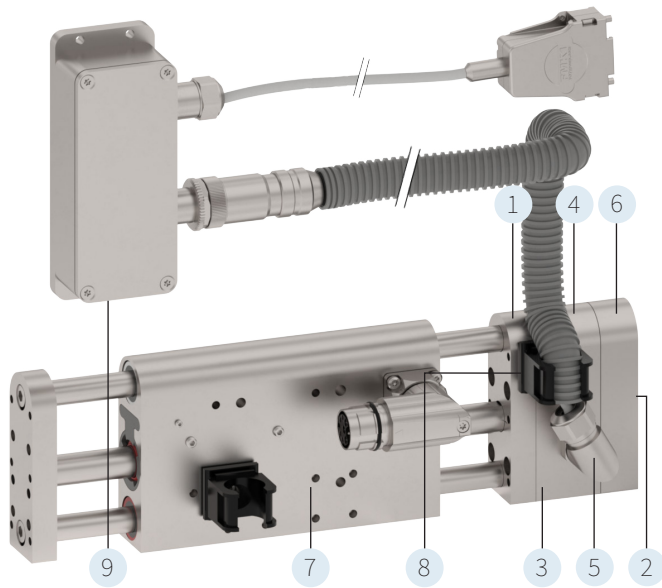

DM01-23-FS23

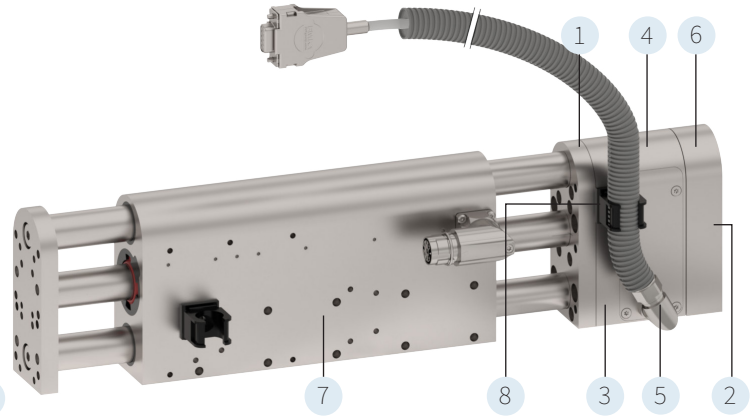

DM01-37-FS22

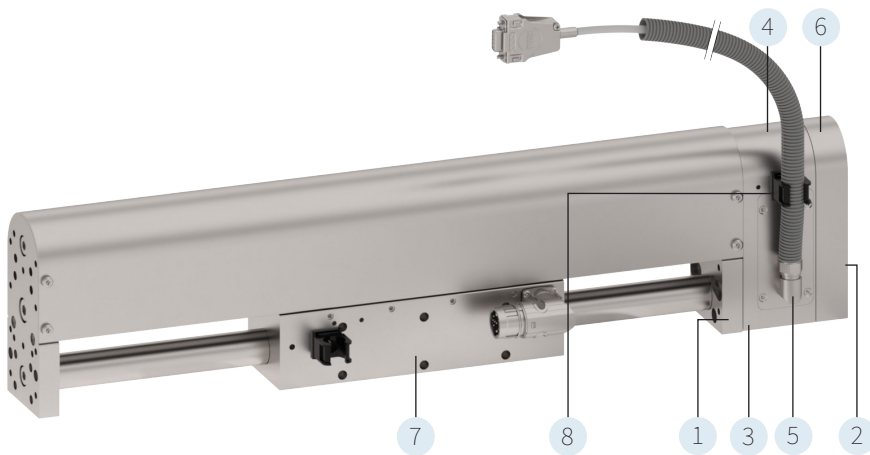

DM01-48-FS25

1. Base plate for direct mounting on the linear modules of the DM01 series
2. Fixing points for the load (gripper, tools, etc.) identical to DM01 linear modules
3. Housing
4. Strain gauge force sensor with built-in sensor amplifier
5. Cable outlet with cable and protective hose
6. Load decoupling
7. DM01 Linear Module
8. Bracket for cable guide
9. Sensor amplifier

Force Sensor Modules

The force sensor modules of the DM01 series can be flanged directly to the DM01 linear modules and thus enable the measurement of the forces occurring in the direction of movement of the modules. Together with the C1250 drives, which can also be calibrated, it is thus possible to either execute a process in a force-controlled manner or to implement process monitoring based on the forces that occur.

The technology of the force measurement modules is based on the proven use of strain gauges (DMS sensors) as used in classic load cells. Such force sensors have already been used successfully with LinMot linear motors and the dedicated technology function "force control". However, with conventional load cells it is important to note that the force must be applied centrally and precisely in the axial direction. In addition, no lateral forces may occur, which also makes it largely impossible

to attach grippers or tools on the side of the force application. From the user's point of view, this severely restricts the possible applications or requires a undesirable design effort. With the newly developed force sensor modules from LinMot, these restrictions no longer apply. The actual force sensor technology was integrated into the force sensor module in such a way that lateral loads are absorbed and unfavorable force application is largely compensated for. The great advantage for the user is that fixtures or grippers can be mounted without affecting the force measurement. A classic +/- 10V signal is generated as the output signal for the LinMot Drives or also for a PLC. The amplifier and evaluation circuitry required for this is built into the force sensor module in a protected manner. This makes the installation of the module as well as its recalibration very simple.

Designation Code Linear Modules DM01 with Force Sensor FS

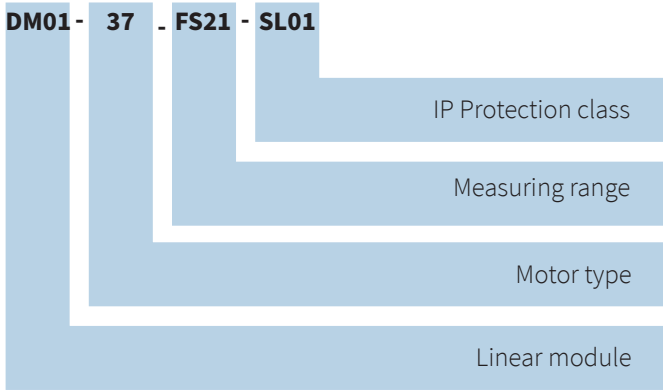

The force sensor modules differ in a number of ways. For each size of DM01 linear module there is a corresponding sensor module. In addition, the customer can choose between different measuring ranges for the force sensors. These are divided into 100 N, 250 N and 500 N. LinMot also offers different protection classes for the sensors. This ensures that the sensors can also be used in demanding environments.

Applications

Typical applications include force-controlled assembly of parts or components. For this purpose, dedicated force control software ("technology function") is installed on the LinMot drives of the C1250 series, which can be used to switch dynamically between position control and force control. This allows parts to be positioned and then assembled with defined pressure. The second group of applications covers the topic of process monitoring. For this purpose, the corresponding force values are continuously recorded and then compared with the target values. Any deviations are used to detect errors or, in the sense

of creeping process changes, to detect them at an early stage. Typically, the "Process Monitoring" application software is installed on the LinMot C1250 Drive. It enables easy monitoring of measured variables by means of freely definable monitoring windows. The following figure shows an example of a closed force control loop. A characteristic feature is the high measuring accuracy despite axially offset force application and external weight influence (gripper and punch), which acts on the output side of the force sensor.

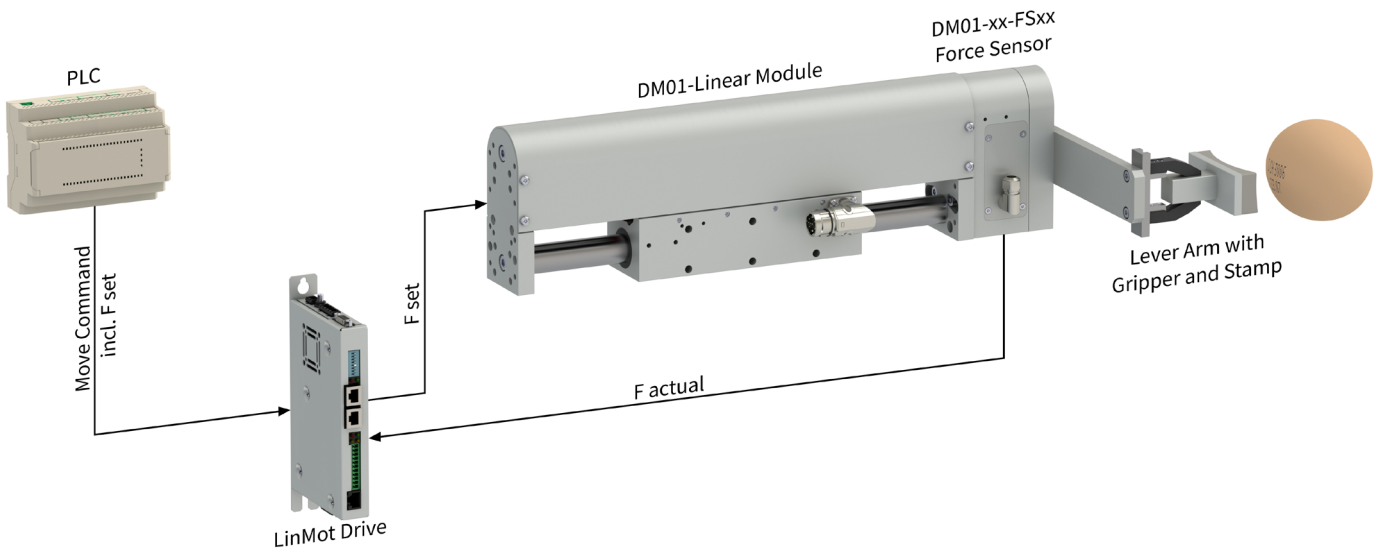

TECHNICAL DATA

			DM01-23-FS23-SL01-VS02	
Supply Voltage	VDC		24	
Measuring Range	N (lbf)		50	(11.24)
Measuring Direction			Tension & Compression	
Boundary Frequency -3dB Measuring Amplifier	kHz		4.4	
Output Signal ¹⁾	VDC		±10	
Current Consumption	mA		<100	
Zero Offset	mV		<100	
Mechanical Overload	Compression Direction	% FS ²⁾	1000	
	Tension Direction	% FS ²⁾	300	
Resolution (C1250 Drive)	Bit		12	
Linearity & Hysteresis	% FS ²⁾		<1	
Nominal Measuring Distance	mm (in)		0.02	(0.0008)
Maximum Shear Force	N		60	
IP Code			IP 40	
Operating Temperature	Nominal	°C	5...45	
	Reduced Accuracy	°C	0...80	
Weight *	g (lb)		316 / 805	(0.70 / 1.77)

* Moving Mass / Total Weight

			DM01-37-FS21-SL01		DM01-37-FS22-SL01	
Supply Voltage	VDC		24		24	
Measuring Range	N (lbf)		100	(22.5)	250	(56.2)
Measuring Direction			Tension & Compression		Tension & Compression	
Boundary Frequency -3dB Measuring Amplifier	kHz		4.4		4.4	
Output Signal ¹⁾	VDC		±10		±10	
Current Consumption	mA		<100		<100	
Zero Offset	mV		<100		<100	
Mechanical Overload	Compression Direction	% FS ²⁾	800		400	
	Tension Direction	% FS ²⁾	400		200	
Resolution (C1250 Drive)	Bit		12		12	
Linearity & Hysteresis	% FS ²⁾		<1		<1	
Nominal Measuring Distance	mm (in)		0.02	(0.0008)	0.02	(0.0008)
Maximum Shear Force	N		400		400	
IP Code			IP 40		IP 40	
Operating Temperature	Nominal	°C	5...45		5...45	
	Reduced Accuracy	°C	0...80		0...80	
Weight	g (lb)		1040	(2.29)	1040	(2.29)

			DM01-48-FS22-SL01		DM01-48-FS25-SL01	
Supply Voltage	VDC		24		24	
Measuring Range	N (lbf)		250	(56.2)	500	(112.4)
Measuring Direction			Tension & Compression		Tension & Compression	
Boundary Frequency -3dB Measuring Amplifier	kHz		4.4		4.4	
Output Signal ¹⁾	VDC		±10		±10	
Current Consumption	mA		<100		<100	
Zero Offset	mV		<100		<100	
Mechanical Overload	Compression Direction	% FS ²⁾	800		500	
	Tension Direction	% FS ²⁾	300		200	
Resolution (C1250 Drive)	Bit		12		12	
Linearity & Hysteresis	% FS ²⁾		<1		<1	
Nominal Measuring Distance	mm (in)		0.02	(0.0008)	0.02	(0.0008)
Maximum Shear Force	N		300		300	
IP Code			IP 40		IP 40	
Operating Temperature	Nominal	°C	5...45		5...45	
	Reduced Accuracy	°C	0...80		0...80	
Weight	g (lb)		1720	(3.79)	1720	(3.79)

1) The sign of the output signal of the force sensor is defined analogue to the default position movement direction of the DM01 module, see assembly instructions.

2) FS = Full Scale

CONNECTOR

Connector Wiring	Force Sensor DSub-9	Wire Color Sensor Cable
Supply GND	1	white
Do not connect	2	n/a
AGND	3	pink
Do not connect	4	n/a
Force +	5	grey
Supply 24V	6	brown
Do not connect	7	n/a
Motlink P	8	green
Force -	9	yellow
Connector Housing	Shield	n/a

DSub-9 Female

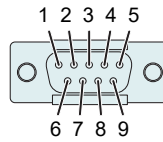

The force sensor has a 2 m cable outlet with a DSub-9 connector at the end of the cable.

PIN 9 (Force -) and PIN 1 (Supply ground) are internally galvanically isolated and must not be connected to each other.

ACCURACY AND CALIBRATION

The force sensors are delivered with a factory calibration certificate valid for two years. After initial commissioning, it is recommended that the sensors are calibrated annually by LinMot (see the 'Recalibration' section).

The following table lists the respective accuracies and factory calibrations of the individual sensor types, along with their

corresponding item numbers. The accuracy and calibration refer to a centric load on the force sensor. Depending on the lever length, a small gain error can be expected in the case of an eccentric load. However, the repeatability of the measurements is still guaranteed.

Force Sensor Type	Factory Calibration Full Range, 1%	Factory Calibration Full Range, 0.5%
DM01-23-FS23-SL01-VS02	0150-6589-00	N/A
DM01-37-FS21-SL01	0150-6120-00	0150-6120-03
DM01-37-FS22-SL01	0150-6121-00	0150-6121-03
DM01-48-FS22-SL01	0150-6122-00	0150-6122-03
DM01-48-FS25-SL01	0150-6125-00	0150-6125-03

RECALIBRATION

Annual recalibration is recommended for normal operating conditions. This cycle may need to be adjusted depending on customer requirements and the application in question.

The same calibration items apply to all sensor types (DM01-23, DM01-37 and DM01-48). The only difference is in accuracy. The following table provides an overview.

Force Sensor Type	Recalibration Full Range, 1%	Recalibration Full Range, 0.5%
DM01-23-FS23-SL01-VS02	0120-6050	N/A
DM01-37-FS21-SL01	0120-6050	0120-6051
DM01-37-FS22-SL01	0120-6050	0120-6051
DM01-48-FS22-SL01	0120-6050	0120-6051
DM01-48-FS25-SL01	0120-6050	0120-6051

PERMISSIBLE ECCENTRIC LOAD

DM01-23-FS23-VS02

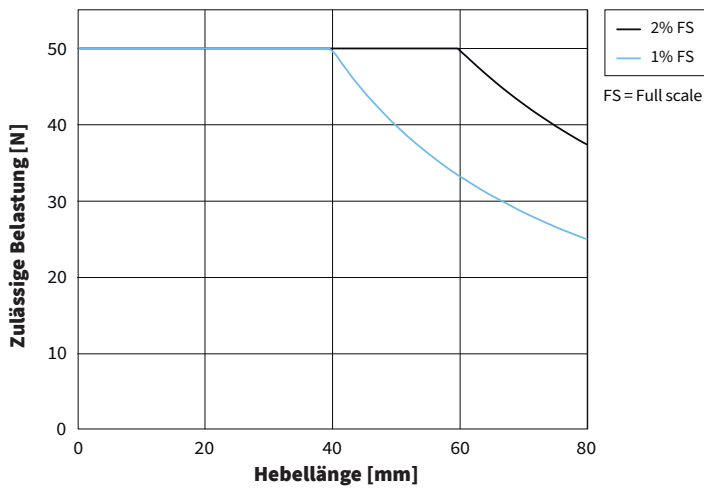

The sensor can absorb an eccentric load up to a certain value. As the distance of the load from the centre increases, the permissible load decreases. This is shown in the graphs below.

DM01-37-FS21

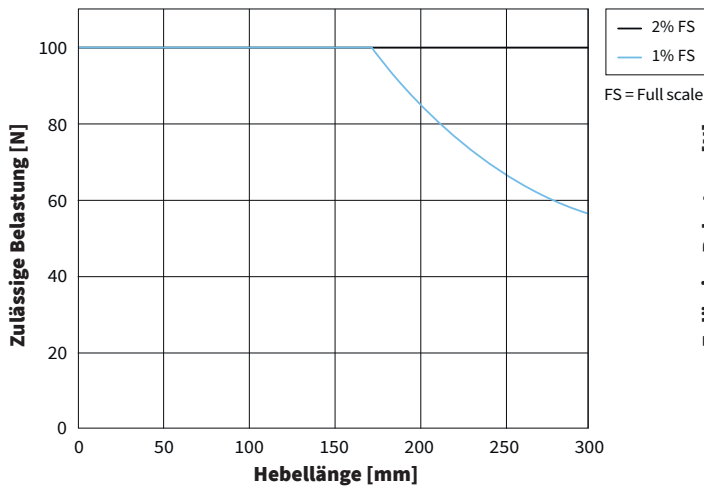

DM01-37-FS22

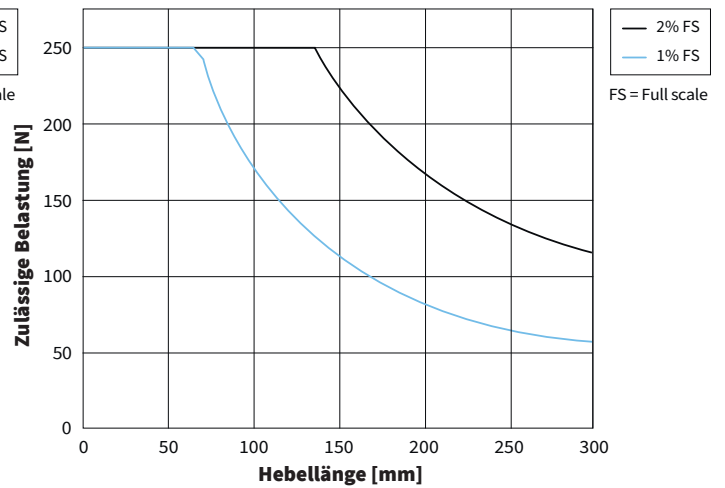

DM01-48-FS22

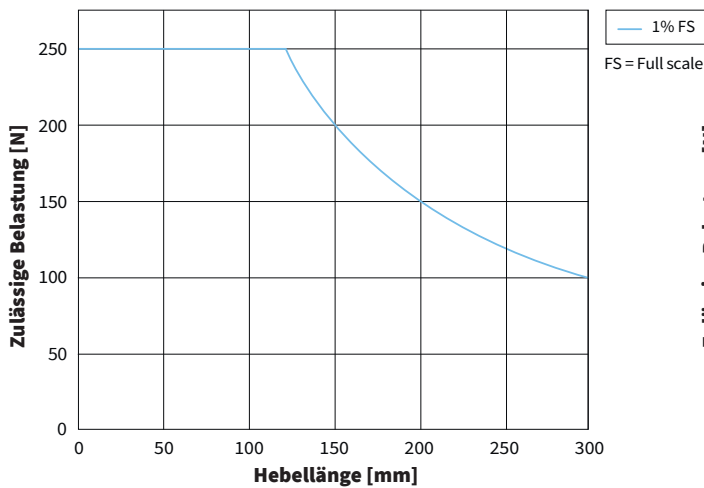

DM01-48-FS25

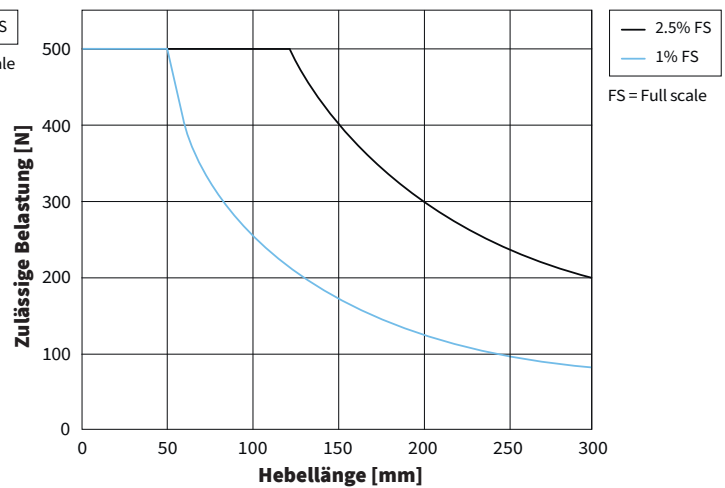

DIMENSIONS DM01-23-FS-VS02

	X-POS.	Y-POS.	
A1	-10	8.50	M4 ∇ 6
A2	-10	33.50	
A3	-10	58.50	
A4	10	8.50	
A5	10	33.50	
A6	10	58.50	
B1	-8.50	27	ϕ 4 H7 0 ∇ 6
B2	8.50	27	

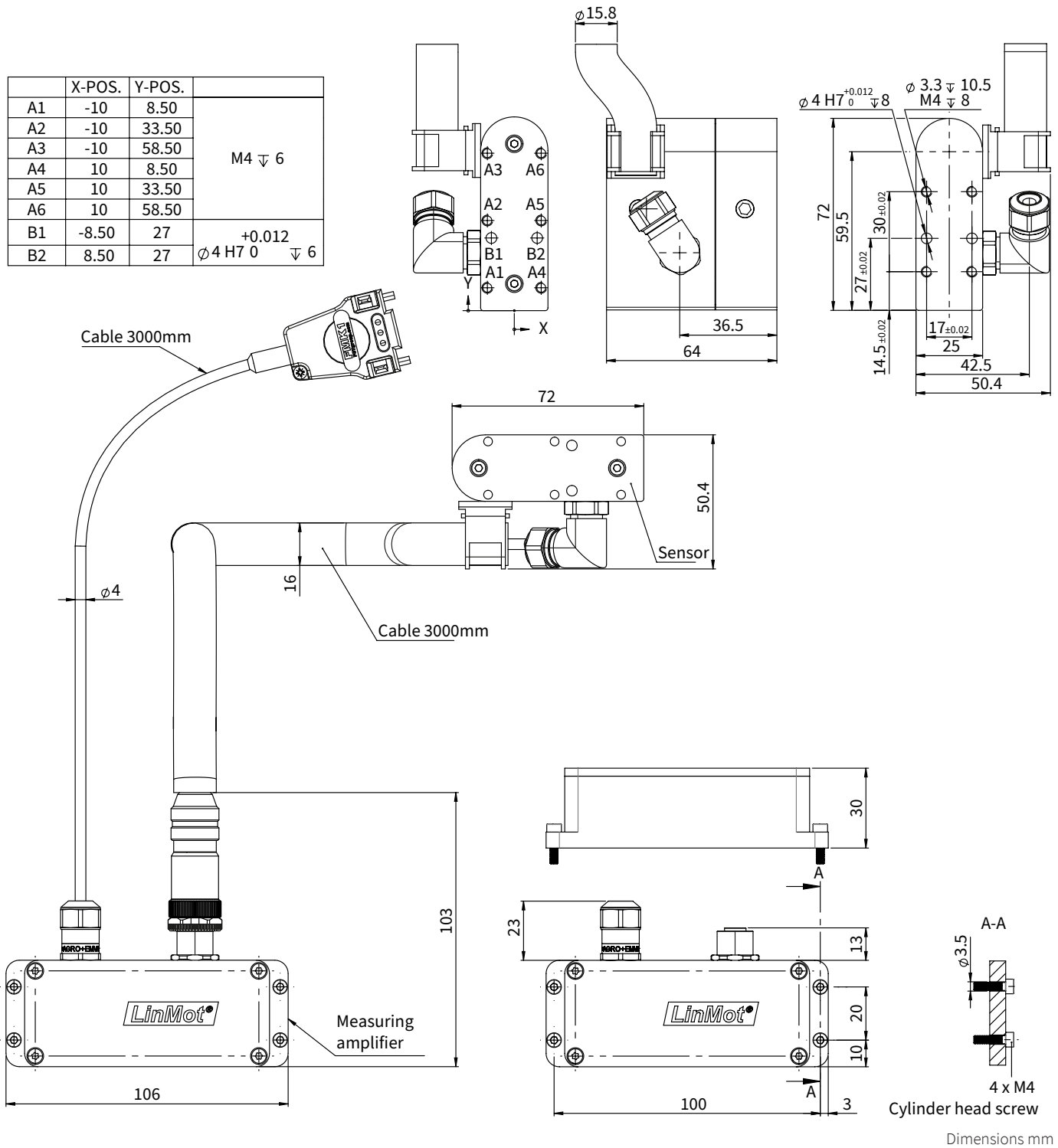

Dimensions mm

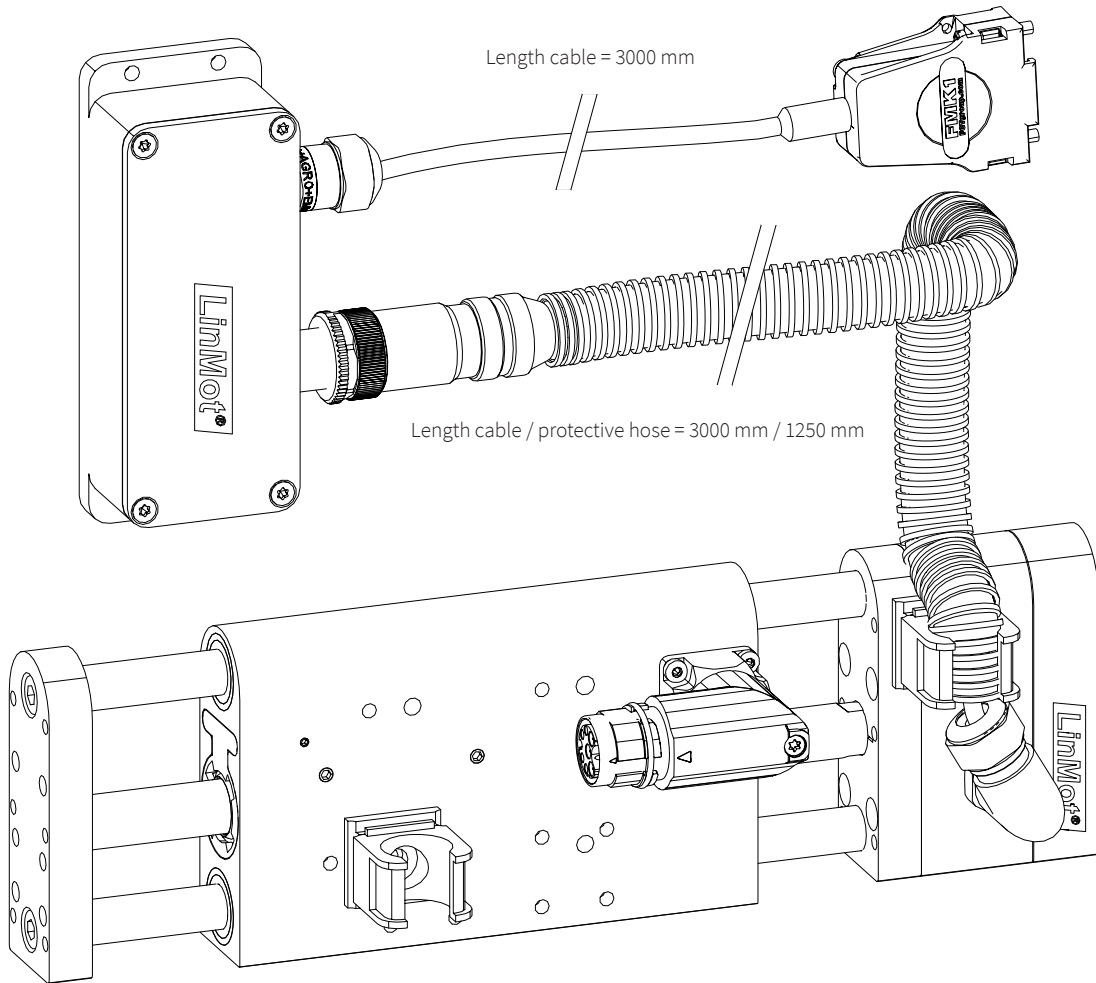

DIMENSIONS DM01-37-FS

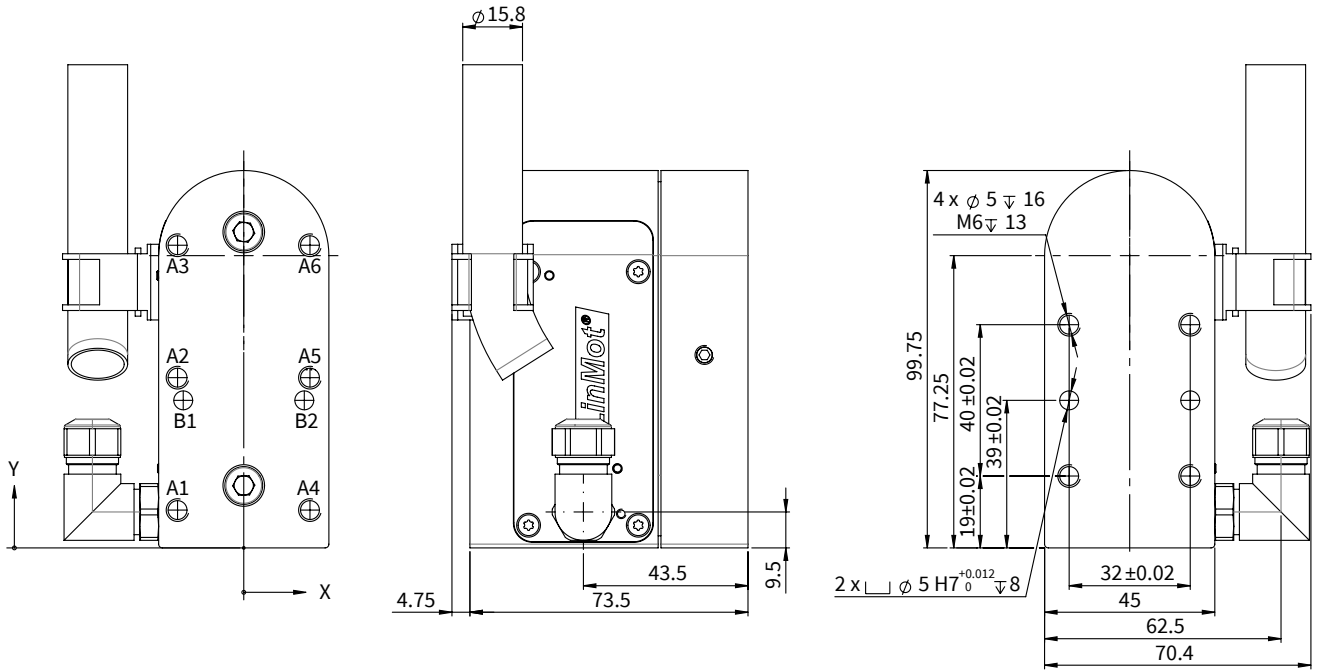

	X-POSITION	Y-POSITION	
A1	-17.50	10	$\phi 5 \downarrow 11$ M6 $\downarrow 9$
A2	-17.50	45	
A3	-17.50	80	
A4	17.50	10	
A5	17.50	45	
A6	17.50	80	
B1	-16	39	$\perp \phi 5 H7 \begin{smallmatrix} +0.012 \\ 0 \end{smallmatrix} \downarrow 8$
B2	16	39	

Dimensions mm

Length cable / protective hose = 2000 mm / 1250 mm

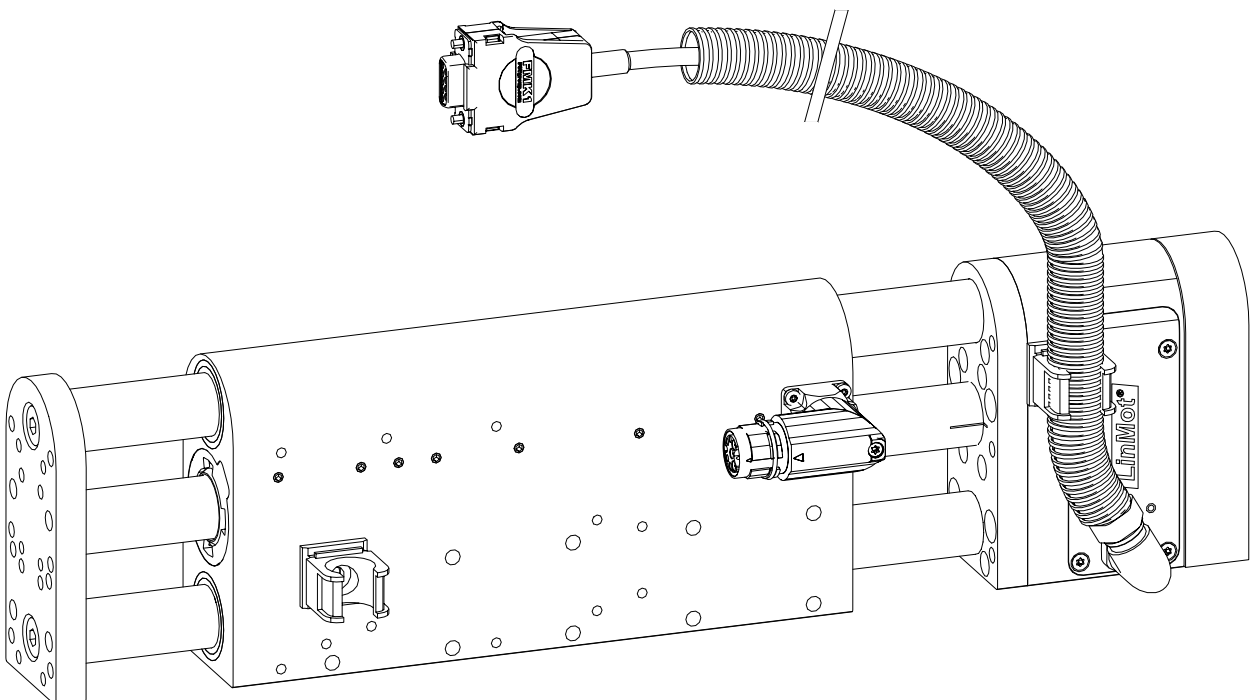

DIMENSIONS DM01-48-FS-25

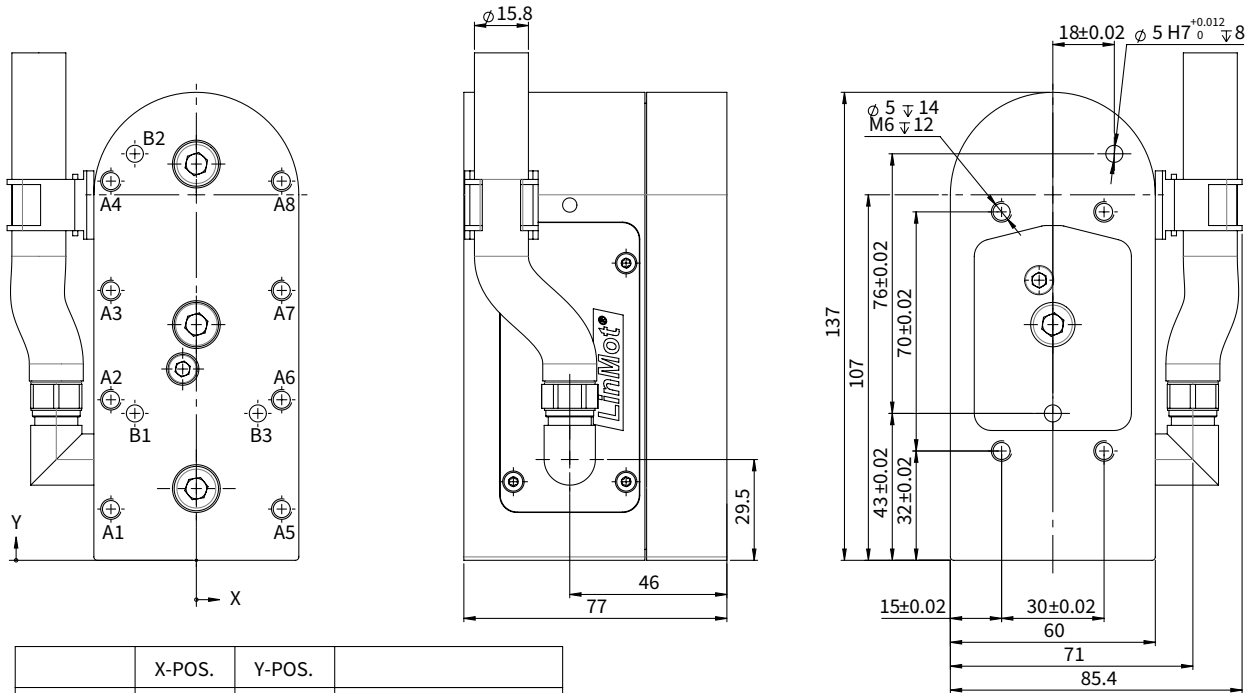

	X-POS.	Y-POS.	
A1	-25	15	$\varnothing 5 \downarrow 13$ $M6 \downarrow 10$
A2	-25	47	
A3	-25	79	
A4	-25	111	
A5	25	15	
A6	25	47	
A7	25	79	
A8	25	111	
B1	-18	43	$\varnothing 5 H7 \quad \begin{matrix} +0.012 \\ 0 \end{matrix} \downarrow 10$
B2	-18	119	
B3	18	43	

Dimensions mm

Length cable / protective hose = 2000 mm / 1250 mm

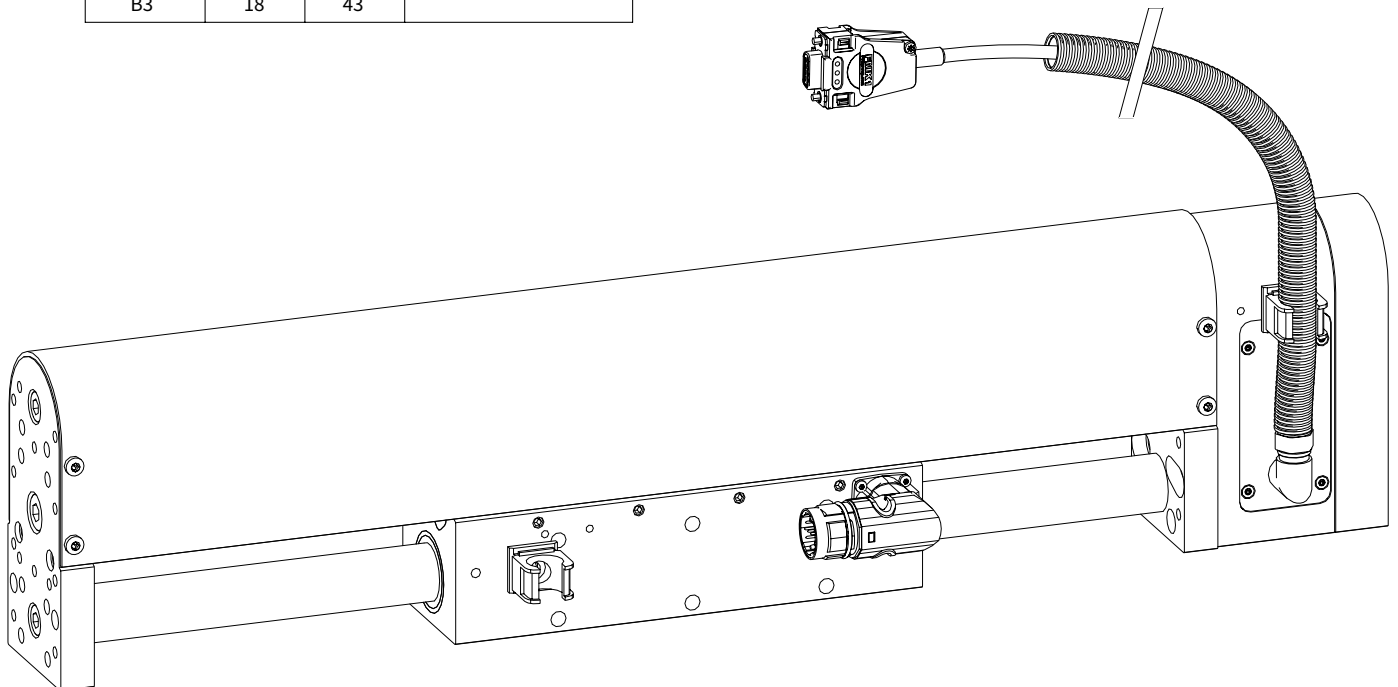

ORDERING INFORMATION

Item	Description	Item-No.
DM01-23-FS23-SL01-VS02	Force sensor kit, +-50 N, Cal. Class A, IP40	0150-6589
DM01-37-FS21-SL01	Force sensor kit, +-100 N, Cal. Class B, IP40	0150-6120
DM01-37-FS22-SL01	Force sensor kit, +-250 N, Cal. Class B, IP40	0150-6121
DM01-48-FS22-SL01	Force sensor kit, +-250 N, Cal. Class B, IP40	0150-6122
DM01-48-FS25-SL01	Force sensor kit, +-500 N, Cal. Class B, IP40	0150-6125
KSS014-06-./D	Sensor Extension Cable for DM01-FSxx, Drive Side Open End	0150-5359

ALL LINEAR MOTION FROM A SINGLE SOURCE

Europe / Asia Headquarters North / South America Headquarters

NTI AG - LinMot & MagSpring

Bodenaeckerstrasse 2
CH-8957 Spreitenbach
Switzerland

☎ +41 (0)56 419 91 91

☎ +41 (0)56 419 91 92

✉ office@linmot.com

🏠 www.linmot.com

LinMot USA, Inc.

N1922 State Road 120, Unit 1
Lake Geneva, WI 53147
United States

☎ 262-743-2555

✉ usasales@linmot.com

🏠 www.linmot-usa.com

🌐 Visit www.linmot.com/contact/ to find your local sales and support contact.