

Installation Guide Linear Motors

ENG

P01-48-HP-SSCP



Content

1	General information	4
1.1	Introduction	4
1.2	Explanation of symbols	4
1.3	Qualified personnel	4
1.4	Liability	4
1.5	Copyright	4
2	Safety instructions	5
3	Installation Instructions	7
3.1	Operating Conditions	7
3.2	Assembly of the Linear Motor	7
3.3	Mounting the Stator	8
3.4	Mounting the Payload to the Slider	8
3.5	"Moving Slider" Installation	10
3.6	"Moving Stator" Installation	10
3.6.1	Assembling Instruction	11
3.7	Minimum Distance from Slider	13
3.7.1	Minimum Distance from Slider to Slider	13
3.7.2	Minimum Distance from Slider to metallic Parts	13
4	Electrical Connection	14
4.1	Motor Cable	14
4.1.1	Technical Data	14
4.2	Connectors	15
4.2.1	Pin Assignment Linear Motor	15
5	Accessories	16
5.1	Motor Cables	16
5.2	Bearing Kit	18
5.2.1	Mounting	18
5.3	Slider Mounting Kits	18
5.3.1	Fixed Bearing	18
5.3.2	Floating Bearing	19
6	Maintenance and Test Instructions	20
6.1	Stator Checking	20
6.2	Maintenance of Linear Motors	20
6.2.1	Maintenance Schedule	20
6.2.2	Cleaning	20
6.2.3	Cleaning Agents / Lubricants	21
7	Storage, Transport, Installation Altitude	21
8	Dimensions	22
8.1	Stator	22
8.1.1	PS01-48x150G-HP-B02-SSCP-C	22
8.1.2	PS01-48x240F-HP-B02-SSCP-C	22
8.2	Slider	23

8.2.1 Slider HP / HCR 23

9 International Certificates 24

10 EU Declaration of Conformity CE-Marking 30

11 UK Declaration of Conformity UKCA-Marking..... 31

1 General information

1.1 Introduction

This manual includes instructions for the assembly, installation, maintenance, transport, and storage of linear motors. The document is intended for electricians, mechanics, service technicians, and warehouse staff. Be sure to observe the general safety instructions as well as those in each chapter at all times. Keep this manual accessible to the assigned staff.

1.2 Explanation of symbols



Triangular warning symbols warn against a danger.



Round command symbols tell what to do.

1.3 Qualified personnel

All work such as transport, installation, commissioning and service is only allowed to be carried out by qualified personnel. Qualified personnel in the sense of the safety instructions in this documentation are persons who are familiar with the transport, installation, assembly, commissioning and operation of the product and who have the appropriate qualifications.

This manual must be read carefully before transport, installation, commissioning, service and all safety-related information must be adhered to.

1.4 Liability

NTI AG (as manufacturer of LinMot linear motors and MagSpring products) excludes all liability for damages and expenses caused by incorrect use of the products. This also applies to false applications, which are caused by NTI AG's own data and notes, for example in the course of sales, support or application activities. It is the sole responsibility of the user to check the information and information provided by NTI AG regarding their safety-relevant correctness. In addition, the entire responsibility for safety-related product functionality lies exclusively with the user. Product warranties are void if products are used with stators, sliders, servo drives or cables not manufactured by NTI AG unless such use was specifically approved by NTI AG. NTI AG's warranty is limited to repair or replacement as stated in our standard warranty policy as described in our "terms and conditions" previously supplied to the purchaser of our equipment (please request copy of same if not otherwise available). Further reference is made to our general terms and conditions.

1.5 Copyright

This work is protected by copyright.

Under the copyright laws, this publication may not be reproduced or transmitted in any form, electronic or mechanical, including photocopying, recording, microfilm, storing in an information retrieval system, not even for training purposes, or translating, in whole or in part, without the prior written consent of NTI AG.

LinMot® is a registered trademark of NTI AG.

2 Safety instructions



Contusions

Sliders contain neodymium magnets and have a strong attractive force. Careless handling could cause fingers or skin to become pinched between two sliders. This may lead to contusions, bruises, and bone fractures.

When handling sliders, wear thick protective gloves and keep a minimum distance between sliders. Refer to the "Minimum distance from slider" section for minimum distance.

To reduce the risk of injury, never more than one slider should be held or transported by the same person without packaging.



Pacemaker / Implanted heart defibrillator

Sliders could affect the functioning of pacemakers and implanted heart defibrillators. For the duration of a strong approach to a magnetic field, these devices switch into test mode and will not function properly.

- If you wear one of those devices keep the following minimum distances between the pacemaker / defibrillator and slider:
 - Min. 250 mm (10") for slider Ø 27 mm and 28 mm (PL01-27 / 28 / PL10-28)
 - Min. 150 mm (6") for slider Ø 19 mm and 20 mm (PL01-19 / 20)
 - Min. 100 mm (4") for slider Ø 12 mm (PL01-12)
- Inform others who wear these devices to comply with these minimum distances!



Caution - Risk of Electric Shock !

Before working, make sure that there are no high voltages.



Fast-moving machine parts

The sliders of LinMot linear motors are fast-moving machine parts. All necessary precautions must be taken to prevent persons approaching the moving elements during operation (provide covers, guards, etc.).



Automatic restart

The motors can start automatically under certain circumstances!

If necessary, a corresponding warning symbol must be provided and protection against entering the hazardous area or a suitable safe electronic disconnection must be provided!



Risk of injury due to a defect or fault

For areas where a defect or fault can result in substantial property damage or even serious personal injury, additional external precautions must be taken or devices must be installed to ensure safe operation even if a defect or fault occurs (eg. suitable safe electronic disconnection, mechanical interlocks, barriers, etc.).



Magnetic field

Magnets integrated in the sliders produce a strong magnetic field. They could damage TVs, laptops, computer hard drives, credit and ATM cards, data storage media, mechanical watches, hearing aids, and speakers.

- Keep magnets away from devices and objects that could be damaged by strong magnetic fields.
- For the above mentioned objects, keep a minimum distance as described in the "Pacemaker / implanted defibrillator" section.
- For non-anti-magnetic watches, keep the double minimum distance.

**Combustibility**

When machining magnets, the drilling dust could easily ignite. Machining the sliders and the magnets they contain is not permitted.

**Burn hazard**

The sliders of LinMot motors can reach temperatures of 80 °C, which may cause burns upon contact.

**Grounding**

All metal parts that are exposed to contact during any user operation or servicing and likely to become energized shall be reliably connected to the means for grounding.

**Mechanical handling**

Neodymium magnets are brittle and heat-sensitive. Machining the sliders and the magnets they contain is not permitted.

- Colliding magnets could crack. Sharp splinters could be catapulted for several meters and cause eye injury.
- By machining the sliders, heat would result which demagnetises the magnets.

**Slider**

Linear motor sliders consist of a high-precision, thin-walled stainless steel tube in which the neodymium magnets are housed. The LinMot sliders should be handled with care. Avoid contact with other sliders or iron parts as this can damage the magnets and the slider surface. Do not grip the sliders with pliers, as this can also damage the surface. Do not use sliders which are already damaged on the surface (scratches, deformation, etc.). This can cause further damage to the stator.

**Effects on people**

According to the current level of knowledge, magnetic fields of permanent magnets do not have a measurable positive or negative effect on people. It is unlikely that permanent magnets constitute a health risk, but it cannot be ruled out entirely.

- For your own safety, avoid constant contact with magnets.
- Store large magnets at least one meter away from your body.

**Temperature resistance**

Keep slider away from unshielded flame or heat. Temperature above 120°C will cause demagnetization.

3 Installation Instructions

3.1 Operating Conditions



Maximum ambient temperature limits:

- 0 °C¹⁾...80 °C

Internal temperature sensor error occurs at:

- 120 °C

¹⁾ Lower temperatures on request.

3.2 Assembly of the Linear Motor



Please attend to the safety instructions in chapter 2 during the assembling!

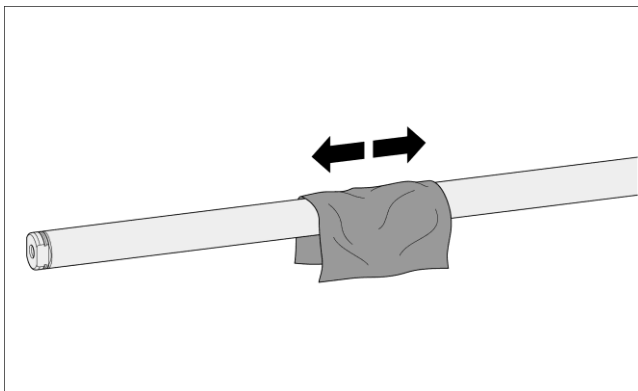

1. Clean the slider with a paper towel.

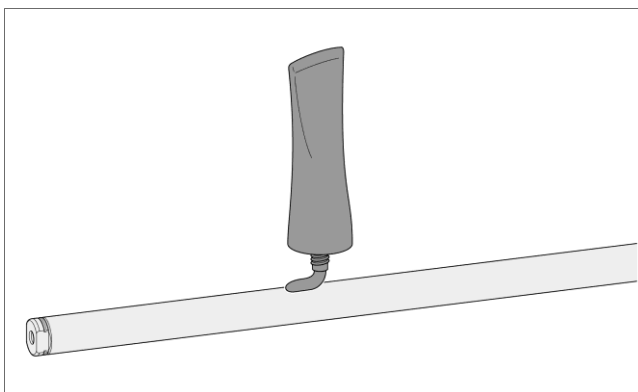

2. Lubricate the slider.

Sliders with a length of more than 500 mm are lubricated with a grease quantity of 4 g (approx. ½ hazelnut) per meter. Shorter sliders are inserted without lubrication.

The grease can be applied by hand or with a soft paper towel.



Always observe the specified grease quantity. Over lubrication leads to a gumming of the grease, which appears particularly at higher operating temperatures!

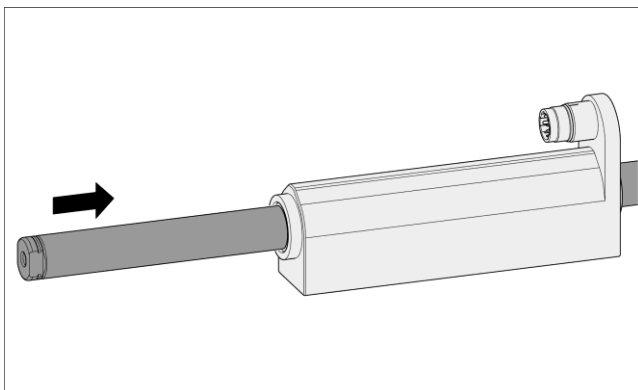

3. Insert the slider in the defined direction (see next assembly step).



Large magnetic attraction forces (Observe warning notice from page 5)!
If necessary, cover obvious iron constructions with non-magnetic material (e.g. wood).

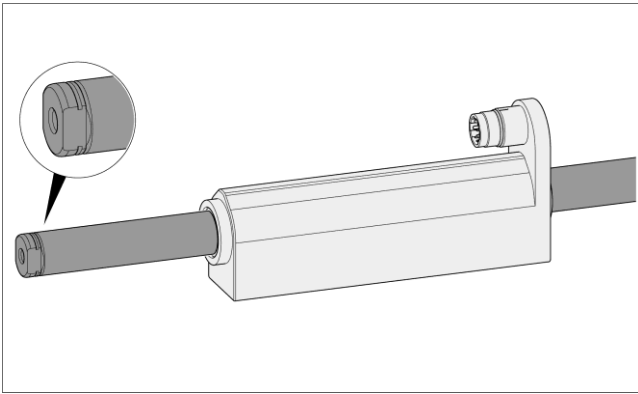

- 4. Checking the installed direction of slider**
After the installation, the front end of the slider is located at the opposite side of the stator from the cable connector or cable exit.

3.3 Mounting the Stator

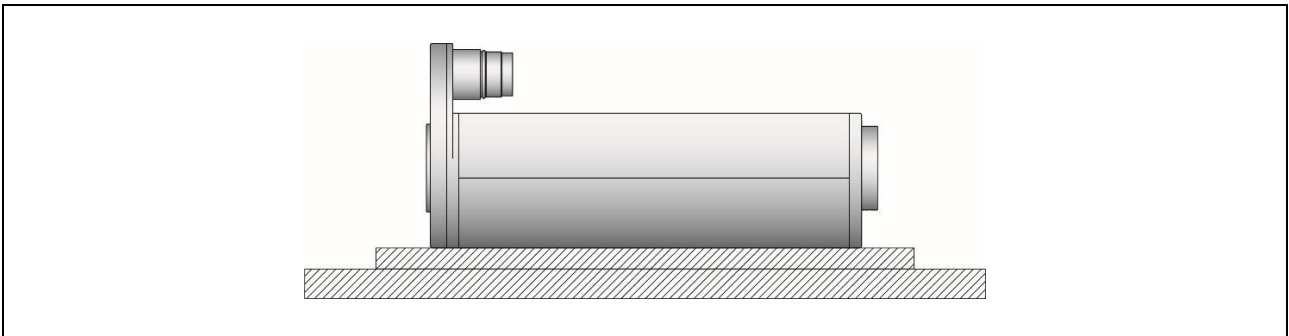

The motor is aligned flat and screwed to the base using the threaded holes on the underside of the motor. The positions of the threaded holes are shown in section 8 «Dimensions».



Max. tightening torque must be observed.

Thread	Max. torque for screw
M6	6 Nm

3.4 Mounting the Payload to the Slider

The load is mounted as a fixed bearing using spherical washers and conical seats (see the section «Slider mounting kits»).



To avoid shear force on slider and wear on stator, the payload has to be beared by a linear guide.

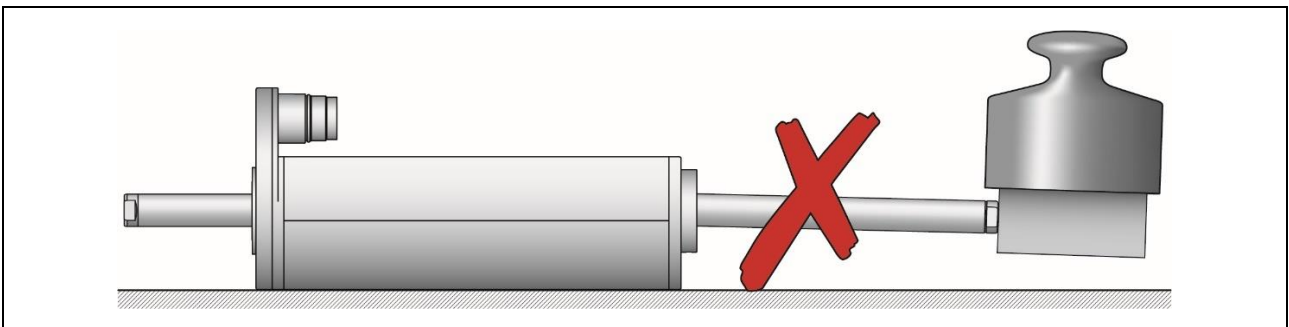

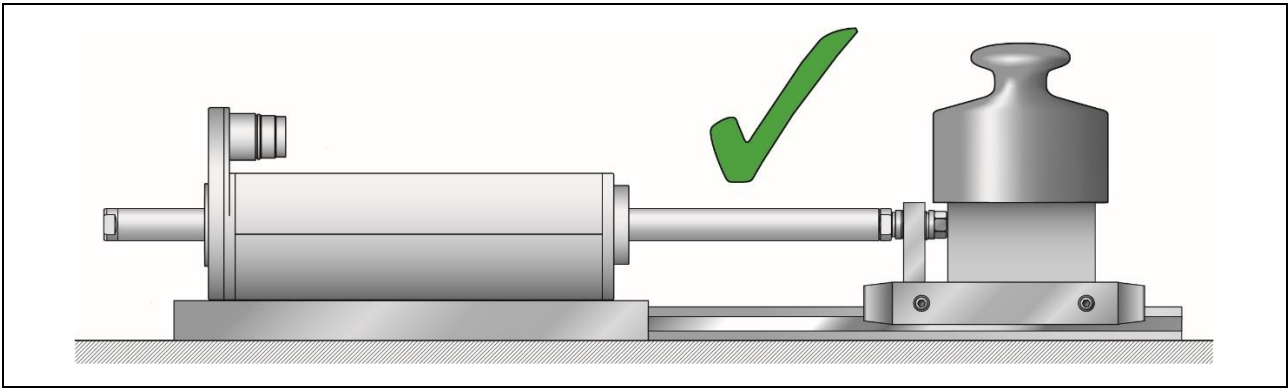

When attaching the load, the wrench for tightening the load must be used only on the load-facing side of the slider. Avoid torsional stress on slider (note the following figures).

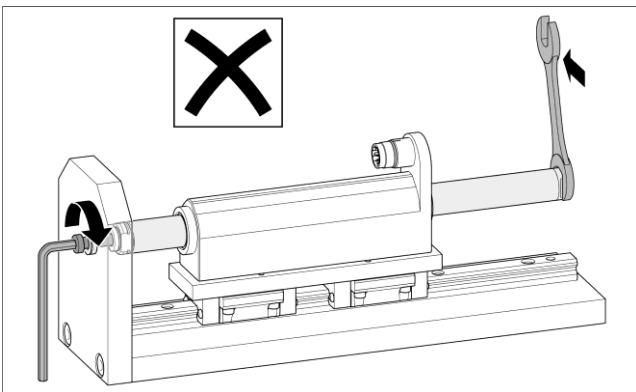

Incorrect Mounting
Torsional stress on slider!

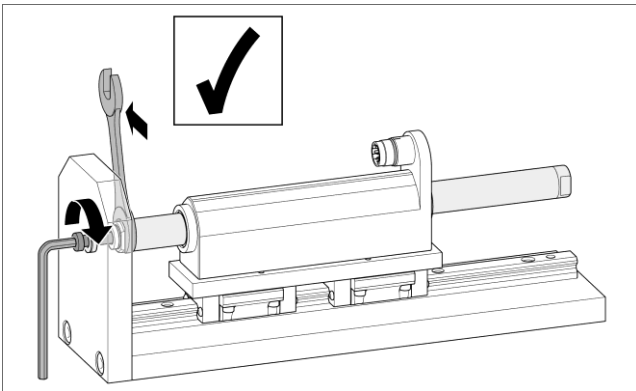

Correct Mounting

Slider	Thread	Max. torque for screw (Stainless steel A4)
28 mm	M10	32 Nm

3.5 "Moving Slider" Installation

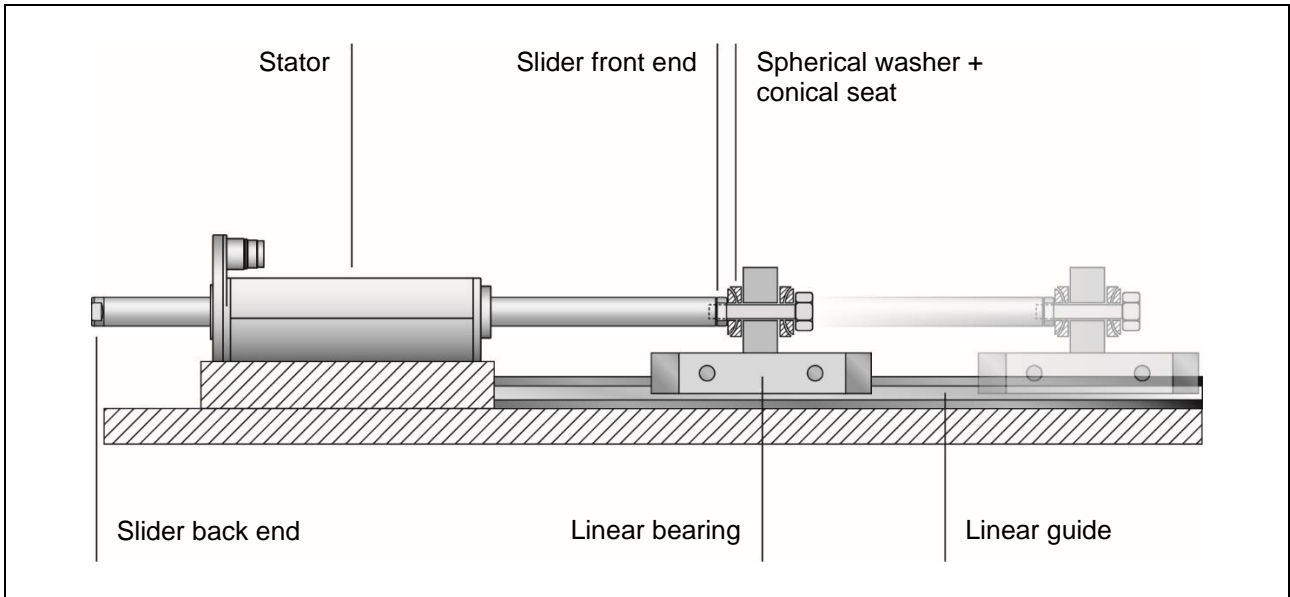

In a "moving slider" installation, the stator is fixed and the slider is the moving part. The load, borne by a linear guide, is attached directly to the end of the slider. In order to compensate for misalignment, spherical axial bearings consisting of spherical washers and conical seats (see the section Slider mounting kits) are used to connect to the load. The mounting kit of slider and an oversized hole for the screw make it possible to adjust a radial and angle offset.

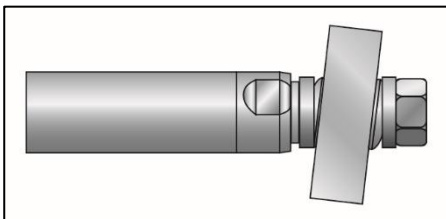

Mounted payload with radial and angle offset.

3.6 "Moving Stator" Installation

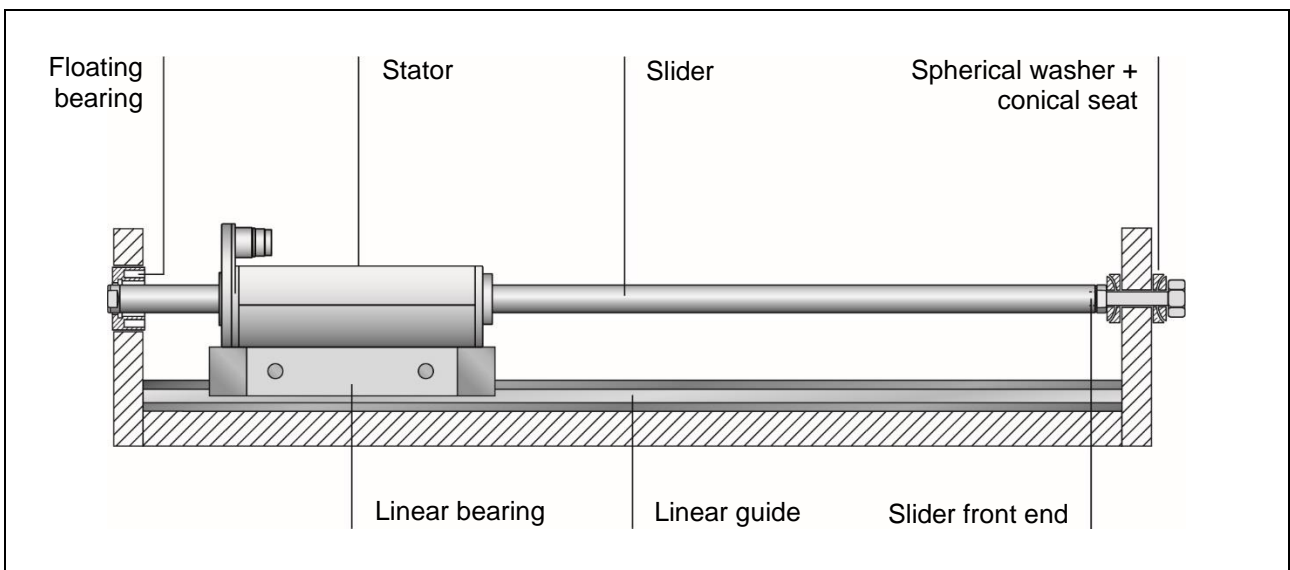

In "moving stator" applications, the slider is fixed and the stator is the moving part. The load is attached to the stator, which is mounted on a linear guide. In order to avoid an overconstrained bearing mount and compensate for alignment errors, the slider may be mounted on one end in a fixed bearing with a spherical axial bearing. On the opposite end, the slider is mounted in a floating bearing. Mounting kits are available for mounting the slider (see the section Slider mounting kits).

3.6.1 Assembling Instruction



Please attend to the safety instructions in chapter 2 during the assembling!



If moving stator application is used, the minimum bending radius of the motor cable should be adhered to. See chapter "Motor cable", section Technical data.

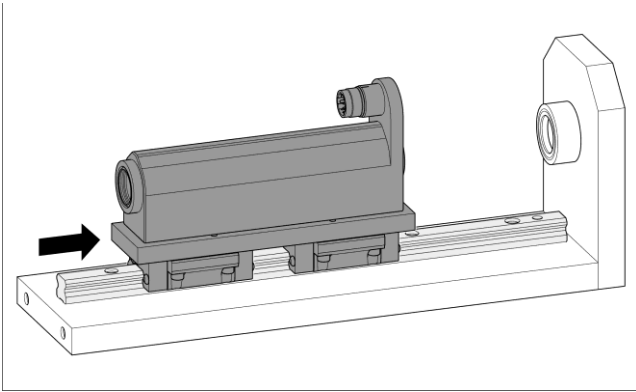

1. Mount stator to its support bearing.

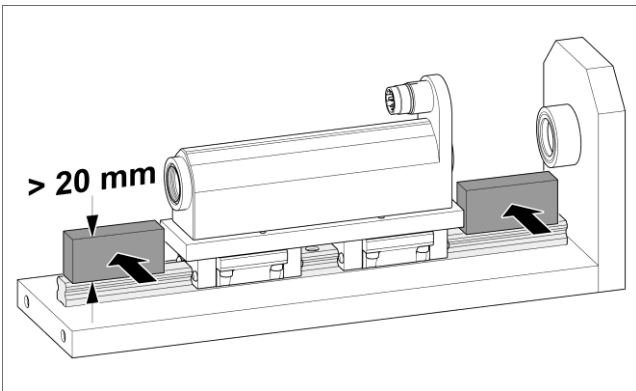

2. Placing a spacer.



Put a spacer (wood, plastic, aluminium with thickness 20 mm) between slider and linear guide. The spacer prevents injuries to the hands and damage to the slider surface!

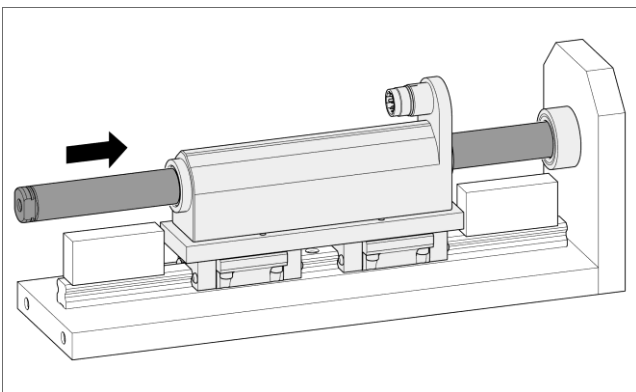

3. Insert slider into stator.

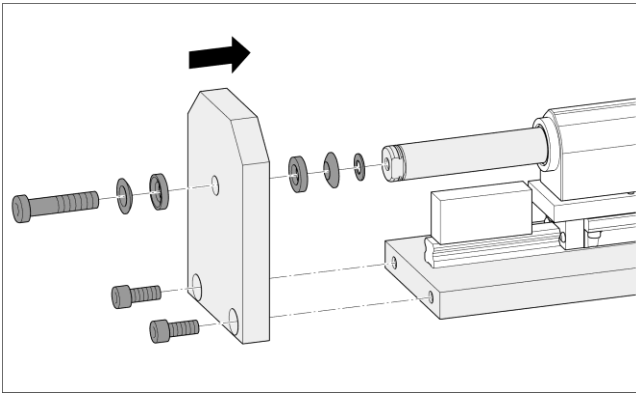

- 4. Installing the slider using the fixed bearing**
The fixed bearing is screwed to the front end of the slider.



Do not tighten the screw yet!

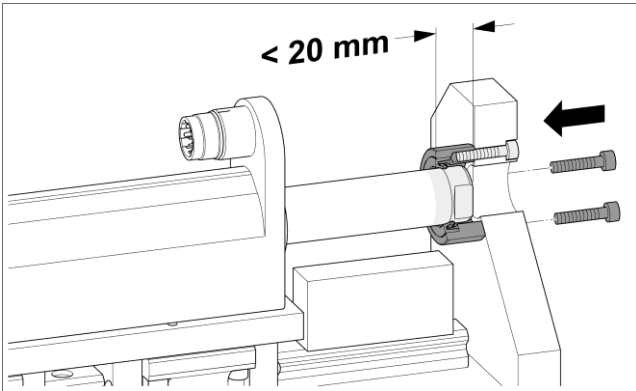

- 5. Mount floating bearing**



Do not tighten the screw!
The slider is allowed to extend into the floating bearing no more than 20 mm!

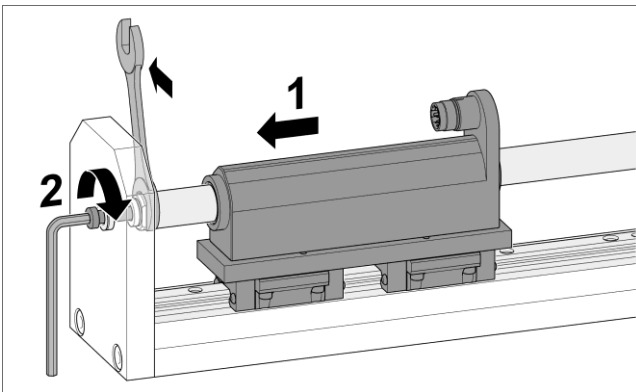

- 6. Move stator (back end) to the fixed end of slider, center slider in stator and tighten the screw.**

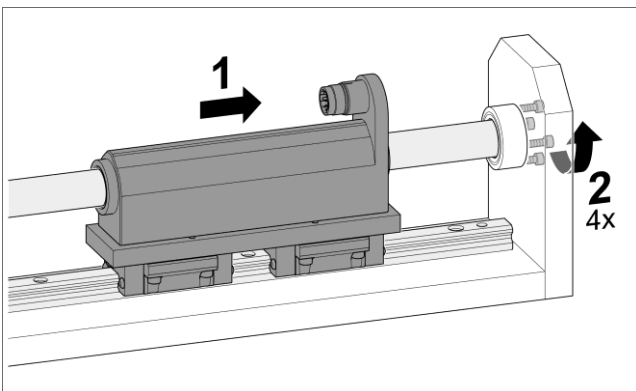

- 7. Move stator (front side) to the floating bearing and tighten screws.**



After the installation of the slider a safety label must be placed close to the slider.

3.7 Minimum Distance from Slider

3.7.1 Minimum Distance from Slider to Slider

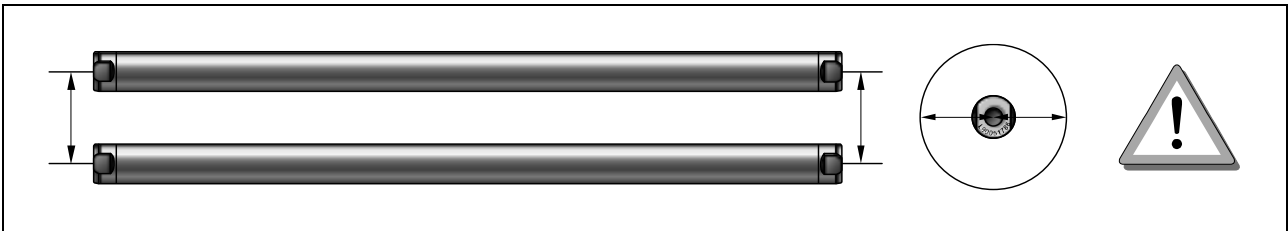

The sliders are made of neodymium magnets and have a strong magnetic attraction. It must be kept a minimum distance between the sliders. This minimized the risk of bruising and secondly, the sliders do not influence each other through their magnetic fields.

Type of slider	PL01	PL01-20 / PL01-19	PL01-28 / PL01-27	PL10-28
PL01-12	30 mm (1.18 in)			
PL01-20 / PL01-19		50 mm (1.97 in)		
PL01-28 / PL01-27			80 mm (3.15 in)	
PL10-28				70 mm (2.76 in)

The data are measured from slider center to slider center.

3.7.2 Minimum Distance from Slider to metallic Parts

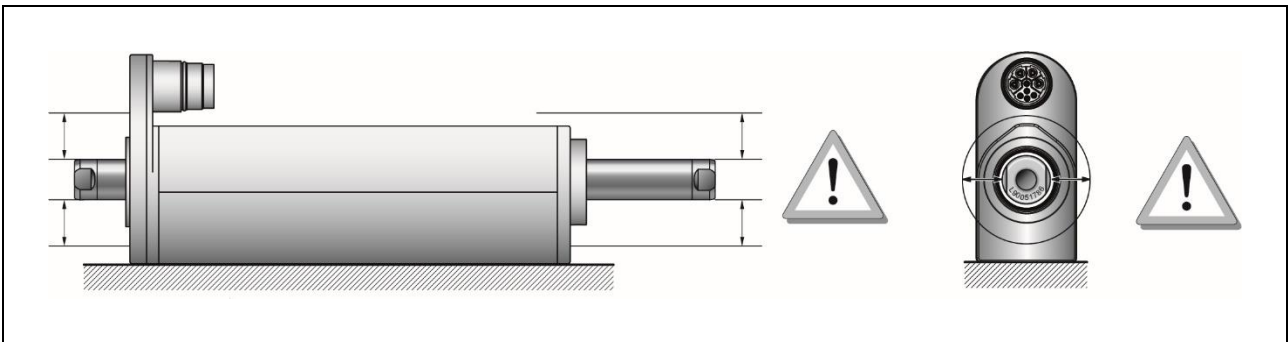

When installing linear motors in modules with metal parts near the slider, undesired forces can arise due to magnetic attraction or eddy currents. These generally manifest as erratic and jerky positioning, or reduced dynamics of the linear motor. In order to avoid this, minimum distances between the slider and any metal parts are to be observed whenever metal materials are used nearby.

Linear Motor	Minimum distance from slider surface to ferromagnetic parts (iron, steel, etc.)	Minimum distance from slider surface to non-ferromagnetic metallic parts (aluminum, bronze, stainless steel, etc.)
P01-48x...	20 mm	10 mm

4 Electrical Connection

4.1 Motor Cable



Do not connect or disconnect motor when there is power on the servo drive. Use only double-shielded original LinMot cable. Cables from other sources must be checked precisely before commissioning. Incorrect connections can destroy the drive and stator.



The stator is connected to protective earth via the motor cable. The screw connections of C connector must be tightened up to the stop. Three types of cables are available for linear motors. The standard motor cable is intended for stationary installation. The High-Flex cable (suitable for trailing chains) and the robot cable are used for moving cable applications.

4.1.1 Technical Data

	Standard cable	High-Flex cable	Robot cable
Cable name	K15-04/05	KS10-04/05	KR10-04/05
Minimum bending radius for fixed installation	50 mm (2 in)	50 mm (2 in)	50 mm (2 in)
Minimum bending radius when moving	Not suitable for applications with moving motor cable	100 mm (4 in) No torsion	100 mm (4 in) Max. torsion: ±270° pro 0.5 m
Approval	UL / CSA 300V	UL / CSA 300V	UL / CSA 300V
Material wire insulation	TPE-U	TPE-E	TPE-E
Material cable sheath	PUR	PUR	PUR
Oil resistance	very good acc. DIN VDE 0282 Part 10 + HD 22.10	very good acc. DIN VDE 0282 Part 10 + HD 22.10	very good acc. DIN VDE 0282 Part 10 + HD 22.10
Chemical resistance (to acids, alkalis, solvents, hydraulic fluid)	good	good	good

4.2 Connectors

For the purpose of complete encapsulation, the C-motor connector is welded onto the housing of the stator. The connector is horizontally aligned and designed to be tightened. All cable connectors with protection class IP 69k are suitable for this motor connector. Motor connector and cable connector are screwed together tightly. The dimensions and tightening torque of the cable connector are shown in the following illustration.

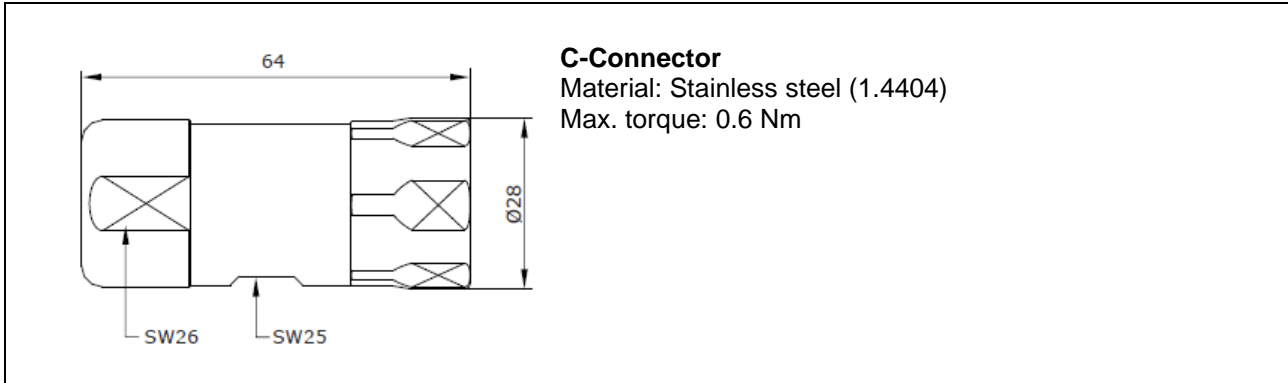

Ordering information

Item	Description	Item-No.
MC01-C/f-IP69K-SSC	Motor connector C/f, IP69k, SSC	0150-3306

4.2.1 Pin Assignment Linear Motor



Do not connect or disconnect motor when there is power on the servo drive. Use only double-shielded original LinMot cable. Cables from other sources must be checked precisely before commissioning. Incorrect connections can destroy the drive and stator.

Connector Type	C-Connector
	Pin
Phase1+	A
Phase1-	B
Phase2+	C
Phase2-	D
+5V	E
GROUND*	F
Sensor Sin	G
Sensor Cos	H
Temp sensor	L
SHIELD** of stator and stator cable	Case
Connector on the stator	



Extension cables are double shielded. The two shields of the extension cables must not be connected together: the inner shield of the extension cables is used as GROUND and must be connected to SIGNAL-GROUND*; only the outer shield must be connected to SHIELD** of the connector.

5 Accessories

5.1 Motor Cables

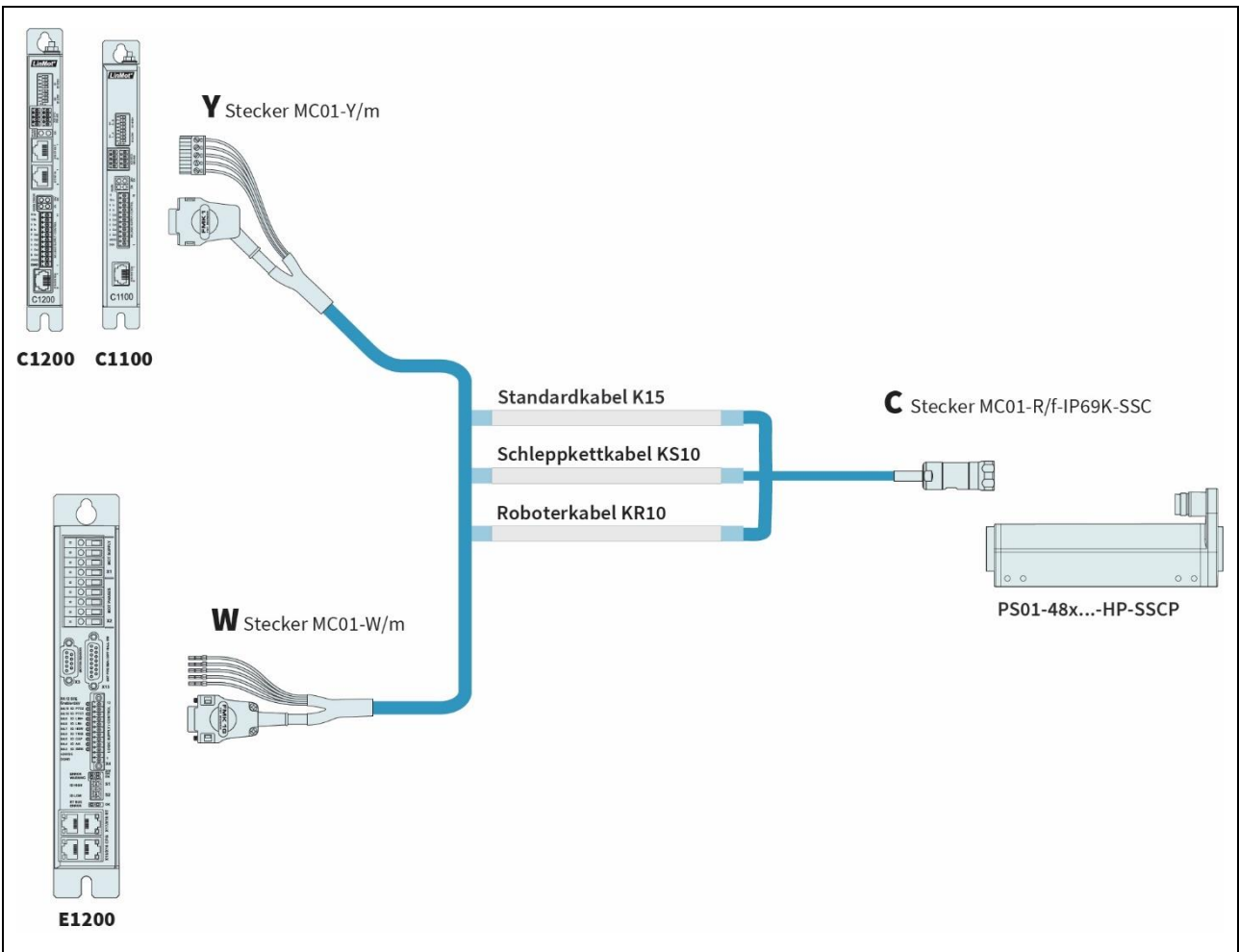

Item	Description	Item-No.
K15-W/C-SSC	Motor Cable W/C-SSC, Custom length	0150-3539
K15-Y-Fe/C-SSC-	Motor Cable Y-Fe/C-SSC, Custom length	0150-3630

Item	Description	Item-No.
KS10-W/C-SSC-2	Trailing Chain Cable W/C-SSC, 2 m	0150-2675
KS10-W/C-SSC-4	Trailing Chain Cable W/C-SSC, 4 m	0150-2676
KS10-W/C-SSC-6	Trailing Chain Cable W/C-SSC, 6 m	0150-2677
KS10-W/C-SSC-8	Trailing Chain Cable W/C-SSC, 8 m	0150-2678
KS10-W/C-SSC-	Trailing Chain Cable W/C-SSC, Custom length	0150-3358
KS10-Y/C-SSC-2	Trailing Chain Cable Y/C-SSC, 2 m	0150-2679

KS10-Y/C-SSC-4	Trailing Chain Cable Y/C-SSC, 4 m	0150-2680
KS10-Y/C-SSC-6	Trailing Chain Cable Y/C-SSC, 6 m	0150-2681
KS10-Y/C-SSC-8	Trailing Chain Cable Y/C-SSC, 8 m	0150-2682
KS10-Y-Fe/C-SSC-	Trailing Chain Cable Y/C-SSC, Custom length	0150-3574

Item	Description	Item-No.
KR10-W/C-SSC-	Robot Cable KR05-W/C-SSC-, Custom length	0150-3536

Item	Description	Item-No.
MC01-W/m	Motor Connector W/m	0150-3140
MC01-Y-Fe/m	Motor Connector Y-Fe/m	0150-3289
MC01-C/f-IP69K-SSC	Motor Connector C/f, IP69K, SSC	0150-3306
K15-04/05	Motor Cable per m	0150-1978
KS10-04/05	Trailing Chain Cable per m	0150-1977
KR10-04/05	Robot Cable per m	0150-1830

5.2 Bearing Kit



For fast, uncomplicated maintenance, the linear motors P01-48-HP-SSCP are equipped with replaceable slider bearings. The integrated sliding bearings are easy to replace in a few manual steps. These plastic bearings are specially designed for food processing and allow easy wash-down of the stator and slider. The available bearing set always consists of 2 wiper rings and the front and rear bearing sleeve.

Item	Description	Item-No.
PBS01-48-B02-SSCP	Spare-Bearing Set for PS01-48x...-B02-SSCP	0150-4715

5.2.1 Mounting

- First remove the old wiper rings and the bearing sleeves.
- The wiper rings can easily be pulled out with pliers. To do this, the bearing sleeves can first be pushed up with a screwdriver and then pulled out with pliers.
- Finally, the new bearing sleeves and the wiper rings can be inserted.



Note that the bearing sleeves are damaged when removed and cannot be reused.

5.3 Slider Mounting Kits

5.3.1 Fixed Bearing

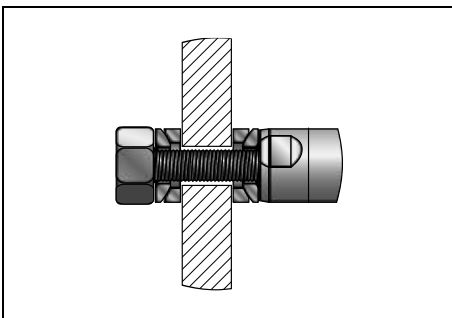

Slider mounting kit consists of a spring washer, a pair of spherical washers, and a pair of conical seats. It allows the slider to be fixed in the direction of motion. It also helps to compensate for radial and angle offset.

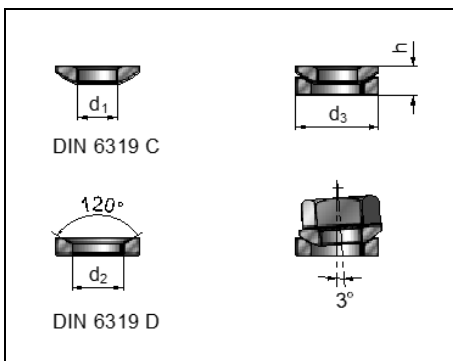

Material

Spherical washer / conical seat: Stainless steel 1.4301

Item	Item No.	Slider	Thread	d1	d2	d3	h
PLF01-28-SS (Stainless steel)	0150-3297	27mm 28mm	M10	10.5mm (0.41in)	12mm (0.47in)	21mm (0.83in)	6.5mm (0.26in)

5.3.2 Floating Bearing

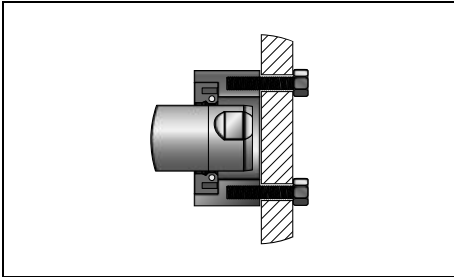

Floating bearing assembly that permits radial adjustment of slider position and permits a small amount of radial and axial movement.

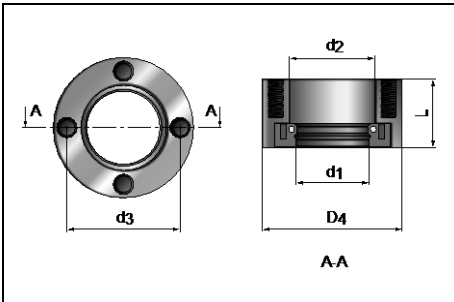

Material

Housing:
Bearing:

Stainless steel 1.4305
Nitrile butadiene rubber
Spring steel DIN17223

Item	Item No.	Slider	Thread	d1	d2	d3	D4	L
PLL01-28	0150-3094	28mm	M5	28mm (1.10in)	32mm (1.26in)	40mm (1.57in)	48mm (1.89in)	20mm (0.79in)

6 Maintenance and Test Instructions

6.1 Stator Checking

The following tables show the resistive value between the different connector pins for each stator type. If the value is not within a range of +/- 10% the stator may be damaged (temperature of the stator for all measurements: 20°C).

PS01-48x150G-HP-B02-SSCP-C (0150-4226)

Phase1+ / Phase1-	Red / Pink	Pin A / Pin B	0.8 Ω
Phase2+ / Phase2-	Blue / Gray	Pin C / Pin D	0.8 Ω
5V / GND	White / Brown	Pin E / Pin F	155 Ω
Sensor Sine / GND	Yellow / Brown	Pin G / Pin F	33 kΩ
Sensor Cosine / GND	Green / Brown	Pin H / Pin F	33 kΩ
Temp. Sensor / GND	Black / Brown	Pin L / Pin F	10 kΩ
Phase / GND	-	Pin A, B, C, D / Pin F	>20 MΩ
All Pin / Shield	-	Pin A-L / Housing	>20 MΩ

PS01-48x240F-HP-B02-SSCP-C (0150-3945)

Phase1+ / Phase1-	Red / Pink	Pin A / Pin B	1.0 Ω
Phase2+ / Phase2-	Blue / Gray	Pin C / Pin D	1.0 Ω
5V / GND	White / Brown	Pin E / Pin F	155 Ω
Sensor Sine / GND	Yellow / Brown	Pin G / Pin F	33 kΩ
Sensor Cosine / GND	Green / Brown	Pin H / Pin F	33 kΩ
Temp. Sensor / GND	Black / Brown	Pin L / Pin F	10 kΩ
Phase / GND	-	Pin A, B, C, D / Pin F	>20 MΩ
All Pin / Shield	-	Pin A-L / Housing	>20 MΩ

6.2 Maintenance of Linear Motors

The person responsible for the operation of the motors must ensure that the specified maintenance work is carried out. The following maintenance schedule is designed for the operating conditions in the food industry with contact of liquid media. The inspection cycle is 2.5 million movement cycles or 1500 friction-kilometer.

6.2.1 Maintenance Schedule

When	What	Task
Every 2.5 million movement cycles or 1500 friction-kilometer	Slider bearing Wiper	Check and, if necessary, replace the bearing sleeves and wiper rings (see section 5.2 «Bearing kit»).
	Slider	Check that the slider surface is clean and not scratched. Scratched sliders must be replaced, otherwise Clean the slider. See the following section.
	Electrical connection	Tighten the electrical connection between cable and stator. Tightening torque: 0.6 Nm (C-Connector)
	Ease of movement	If friction is felt during movement, the motor must be stopped immediately. Check the alignment of the load bearing and slider.

6.2.2 Cleaning

- Pull the sliders carefully out of the stator.
Attention! Strong magnetic attraction forces (note safety instruction “contusions” on page 5.)! Use non-magnetic material (e.g. wood) to cover close-by iron constructions.
- Clean the slider and bearings with a soft disposable paper, using for example acetone or benzene cleaner. Common cleaning agents used in the food industry may also be used. However, these should not leave any residues.

- Then, if the application allows, the slider and the bearings should be lubricated. The bearings are each greased with 1 g grease LU02. There should only be a light layer of grease on the inside. **Note!:** Avoid overlubrication!
Finally, grease the slider according to paragraph 3.2 "Assembly of the linear motor".

6.2.3 Cleaning Agents / Lubricants

All LinMot stainless steel motors have a protection class of IP69. Standard cleaning agents in food and pharmaceutical industries with usual concentration and amount, can be used for the cleaning. If necessary, the compatibility with the bearing material (PEEK / PPS), the wiper material (NBR FDA) and the cable sheath material (PUR) must be checked.

Ordering information

Item	Description	Item-No.
LU02-08	Lubricant for linear motors * (8 g)	0150-1953
LU02-50	Lubricant for linear motors * (50 g)	0150-1954
LU02-1000	Lubricant for linear motors * (1000 g)	0150-1955
* LinMot LU02 Lubricant corresponds to KLÜBERSYNTH UH1 14-31 which was developed for the food processing industry.		

7 Storage, Transport, Installation Altitude

- Sliders are to be stored and transported only in the plastic containers (with cardboard inlay) provided for this purpose, or already installed and secured in LinMot P stators.
- Remove the slider from this plastic containers only for assembling.
- The storage area must be dry, dust-free, frost-free and vibration-free.
- Prescribed storage temperature: -15 °C...70 °C
- The motor must be protected against extreme weather conditions.
- The air in the storage area must not contain any harmful gases.
- The max. installation altitude is 4'000 m above sea level.
Beyond 1'000 m, a derating of 0.5% per 100 m must be taken into account on the rated force in the case of air cooling.

8 Dimensions

8.1 Stator

8.1.1 PS01-48x150G-HP-B02-SSCP-C

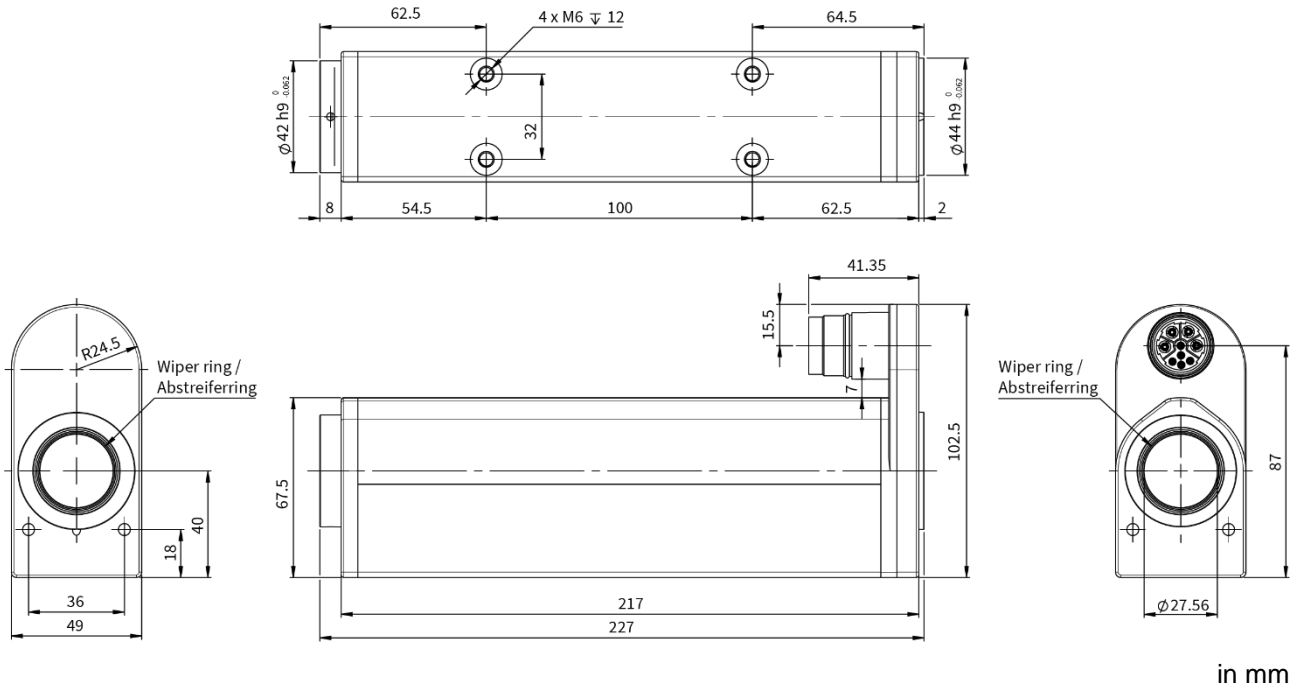

8.1.2 PS01-48x240F-HP-B02-SSCP-C

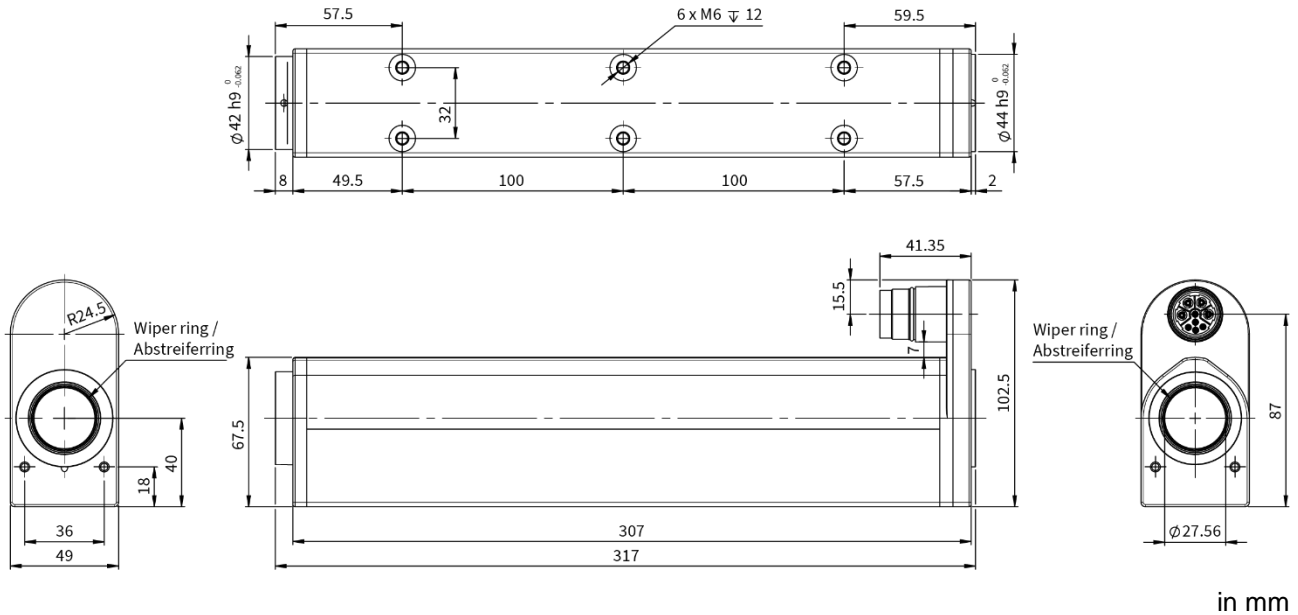

8.2 Slider

For normal applications in both dry and wet environments the standard sliders of the PL01 series are sufficient. Their slider tube is made of an austenitic, acid-resistant 18/10 chrome-nickel steel, material no. 1.4301 (AISI 304). The heavy duty sliders PL02 are additionally coated with tungsten carbide (WC/C), have better emergency running properties and are superior to standard sliders in terms of service life in abrasive environments. Sliders of the HCR series ("high corrosion resistant") are made of stainless steel 1.4404 - chrome-nickel-molybdenum (AISI 316L). Their use is particularly recommended in environments with a high chloride content at temperatures above 60°C.

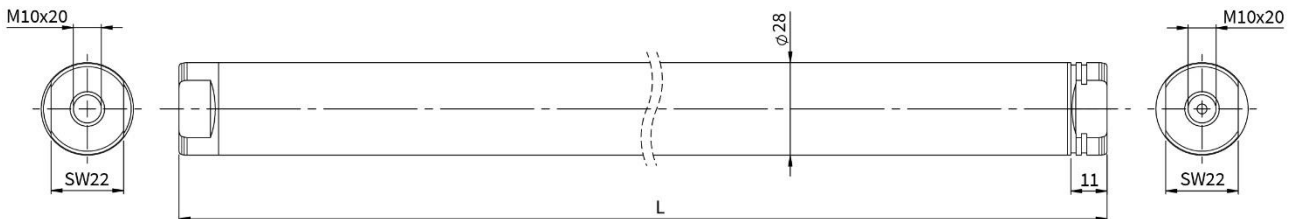

8.2.1 Slider HP / HCR



Item	Description	Item-No.	Length L [mm]
PL01-28x260/210-HP	Slider 'High Performance'	0150-3861	260
PL01-28x290/240-HP	Slider 'High Performance'	0150-3862	290
PL01-28x350/300-HP	Slider 'High Performance'	0150-3820	350
PL01-28x410/360-HP	Slider 'High Performance'	0150-3821	410
PL01-28x500/450-HP	Slider 'High Performance'	0150-3822	500
PL01-28x620/570-HP	Slider 'High Performance'	0150-3823	620
PL01-28x710/660-HP	Slider 'High Performance'	0150-3824	710
PL01-28x800/750-HP	Slider 'High Performance'	0150-3825	800
PL01-28x920/870-HP	Slider 'High Performance'	0150-3878	920
PL01-28x1010/960-HP	Slider 'High Performance'	0150-3827	1010
PL01-28x1220/1170-HP	Slider 'High Performance'	0150-3828	1220
PL01-28x1400/1350-HP	Slider 'High Performance'	0150-3829	1400
PL01-28x1610/1560-HP	Slider 'High Performance'	0150-3830	1610

Item	Description	Item-No.	Length L [mm]
PL01-28x260/210-HP-W01	Slider 'High Performance' HCR	0150-4259	260
PL01-28x290/240-HP-W01	Slider 'High Performance' HCR	0150-4288	290
PL01-28x350/300-HP-W01	Slider 'High Performance' HCR	0150-4289	350
PL01-28x410/360-HP-W01	Slider 'High Performance' HCR	0150-4290	410
PL01-28x500/450-HP-W01	Slider 'High Performance' HCR	0150-4291	500
PL01-28x620/570-HP-W01	Slider 'High Performance' HCR	0150-4292	620
PL01-28x710/660-HP-W01	Slider 'High Performance' HCR	0150-4293	710
PL01-28x800/750-HP-W01	Slider 'High Performance' HCR	0150-4294	800
PL01-28x920/870-HP-W01	Slider 'High Performance' HCR	0150-4295	920
PL01-28x1010/960-HP-W01	Slider 'High Performance' HCR	0150-4296	1010
PL01-28x1220/1170-HP-W01	Slider 'High Performance' HCR	0150-4297	1220
PL01-28x1400/1350-HP-W01	Slider 'High Performance' HCR	0150-4298	1400
PL01-28x1610/1560-HP-W01	Slider 'High Performance' HCR	0150-4299	1610

9 International Certificates

<p>Europe</p> 	<p>See chapter "EU Declaration of Conformity CE-Marking"</p>
<p>UK</p> 	<p>See chapter "UK Declaration of Conformity UKCA-Marking"</p>
<p>IECEE CB SCHEME</p>	<p>Ref. Certif. Nr. CH-8521</p>
<p>USA / Canada</p> 	<p>File Number E354430 Refers to cURus marked motors</p>

	Ref. Certif. No. CH-8521
---	---------------------------------



IEC SYSTEM FOR MUTUAL RECOGNITION OF TEST CERTIFICATES FOR ELECTRICAL EQUIPMENT (IECEE) CB SCHEME

CB TEST CERTIFICATE

Product	Linear motor	
Name and address of the applicant	NTI AG	Bodenackerstrasse 2 SWITZERLAND 8957 Spreitenbach
Name and address of the manufacturer	NTI AG	Bodenackerstrasse 2 SWITZERLAND 8957 Spreitenbach
Name and address of the factory	NTI AG	Bodenackerstrasse 2 SWITZERLAND 8957 Spreitenbach
<i>Note: When more than one factory, please report on page 2</i>	<input type="checkbox"/> Additional Information on page 2	
Ratings and principal characteristics	supplied via servo drive, see TR 17-EL-0006.E02 for details	
Trade mark (if any)	LinMot	
Customers's Testing Facility (CTF) Stage used	---	
Model / Type Ref.	PR series PS series P04 series P05 series	
Additional information (if necessary may also be reported on page 2)	---	
	<input type="checkbox"/> Additional Information on page 2	
A sample of product was tested and found to be in conformity with IEC	IEC 61000-6-2:2016 IEC 61000-6-4:2006, IEC 61000-6-4:2006/AMD1:2010 IEC 61000-6-7:2014	
National differences	EU Group Differences; EU Special National Conditions; EU A-Deviations	
As shown in the Test Report Ref. No. which forms part of this Certificate	17-EL-0006.E01 + .E02 + .Z01	



This CB Test Certificate is issued by the National Certification Body

Electrosuisse Luppenstrasse 1 8320 Fehraltorf SWITZERLAND		 electro suisse
Signed by: Martin Plüss		
Date: 2017-03-13		page 1 of 1

CERTIFICATE OF COMPLIANCE

Certificate Number UL-US-2138367-0
Report Reference E354430-20210817
Date 23-Aug-2021

Issued to: NTI AG
Bodenaeckerstr 2 SPREITENBACH
Switzerland 8957

**This is to certify that
representative samples of**

NDMM2 - Incomplete Rotating Machines and Rotating
Machine Parts - Component

See Addendum Page for Product Designation(s).

Have been investigated by UL in accordance with the
component requirements in the Standard(s) indicated on
this Certificate. UL Recognized components are incomplete
in certain constructional features or restricted in
performance capabilities and are intended for installation in
complete equipment submitted for investigation to UL LLC.

Standard(s) for Safety: UL 1004-1, 2nd Ed., Issue Date: 2012-09-19, Revision
Date: 2020-11-05

Additional Information: See the UL Online Certifications Directory at
<https://iq.ulprospector.com> for additional information

This *Certificate of Compliance* does not provide authorization to apply the UL Recognized Component Mark.
Only the UL Follow-Up Services Procedure provides authorization to apply the UL Mark.

Only those products bearing the UL Recognized Component Mark should be considered as being UL Certified
and covered under UL's Follow-Up Services.

Look for the UL Recognized Component Mark on the product.

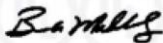

Bruce Mahrenholz, Director North American Certification Program

UL LLC

Any information and documentation involving UL Mark services are provided on behalf of UL LLC (UL) or any authorized licensee of UL. For questions, please
contact a local UL Customer Service Representative at <http://ul.com/aboutul/locations/>



CERTIFICATE OF COMPLIANCE

Certificate Number UL-US-2138367-0
Report Reference E354430-20210817
Date 23-Aug-2021

This is to certify that representative samples of the product as specified on this certificate were tested according to the current UL requirements

Model	Category Description
PS01 , PS01, Followed by 2 digits, Followed by "x" or "Sx", Followed by 2 or 3 digits, Followed by "-", "F", "H" or "G", Followed by HP, followed by "B" plus 2 digits, Followed by SSCP, followed by "G" plus 2 digits (optional), followed by R, C, H, M or MF, Followed by 2 or 3 digits (optional), followed by any alphanumeric digit (optional)	Incomplete Motor Parts
SM01 , SM01, Followed by 2 digits, Followed by "x" or "Sx", Followed by 2 or 3 digits, Followed by "-", "F", "H" or "G", Followed by HP, Followed by R, C, H, M or MF, Followed by 2 or 3 digits (Optional), Followed by 2 or 3 digits, Followed by "BE" plus 2 digits (Optional), Followed by "MS" plus 2 digits (Optional), Followed by "EN" plus 2 digits (Optional), Followed by "FS" plus 2 digits (Optional), Followed by "BK" plus 2 digits (Optional), Followed by SSCP, followed by "-" or any alphanumeric digit.	Incomplete Motor Parts
SM02 , SM02, Followed by 2 digits, Followed by "x" or "Sx", Followed by 2 or 3 digits, Followed by "-", "F", "H" or "G", Followed by HP, Followed by R, C, H, M or MF, Followed by 2 or 3 digits (Optional), Followed by 2 or 3 digits, Followed by "BE" plus 2 digits (Optional), Followed by "MS" plus 2 digits (Optional), Followed by "EN" plus 2 digits (Optional), Followed by "FS" plus 2 digits (Optional), Followed by "BK" plus 2 digits (Optional), Followed by SSCP, followed by "-" or any alphanumeric digit.	Incomplete Motor Parts

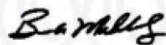

Bruce Mahrenholz, Director North American Certification Program

UL LLC

Any information and documentation involving UL Mark services are provided on behalf of UL LLC (UL) or any authorized licensee of UL. For questions, please contact a local UL Customer Service Representative at <http://ul.com/aboutul/locations/>



CERTIFICATE OF COMPLIANCE

Certificate Number UL-CA-2128754-0
Report Reference E354430-20210817
Date 23-Aug-2021

Issued to: NTI AG
Bodenaeckerstr 2 SPREITENBACH
Switzerland 8957

This is to certify that representative samples of NDMM8 - Incomplete Rotating Machines and Rotating Machine Parts Certified for Canada - Component
See Addendum Page for Product Designation(s).

Have been investigated by UL in accordance with the component requirements in the Standard(s) indicated on this Certificate. UL Recognized components are incomplete in certain constructional features or restricted in performance capabilities and are intended for installation in complete equipment submitted for investigation to UL LLC.

Standard(s) for Safety: CSA C22.2 NO. 100, 7th Ed., Issue Date: 2014-07-01, Revision Date: 2017-04-01

Additional Information: See the UL Online Certifications Directory at <https://iq.ulprospector.com> for additional information

This *Certificate of Compliance* does not provide authorization to apply the UL Recognized Component Mark. Only the UL Follow-Up Services Procedure provides authorization to apply the UL Mark.

Only those products bearing the UL Recognized Component Mark should be considered as being UL Certified and covered under UL's Follow-Up Services.

Look for the UL Recognized Component Mark on the product.

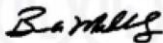

Bruce Mahrenholz, Director North American Certification Program

UL LLC

Any information and documentation involving UL Mark services are provided on behalf of UL LLC (UL) or any authorized licensee of UL. For questions, please contact a local UL Customer Service Representative at <http://ul.com/aboutul/locations/>



CERTIFICATE OF COMPLIANCE

Certificate Number UL-CA-2128754-0
Report Reference E354430-20210817
Date 23-Aug-2021

This is to certify that representative samples of the product as specified on this certificate were tested according to the current UL requirements

Model	Category Description
PS01 , PS01, Followed by 2 digits, Followed by "x" or "Sx", Followed by 2 or 3 digits, Followed by "-", "F", "H" or "G", Followed by HP, followed by "B" plus 2 digits, Followed by SSCP, followed by "G" plus 2 digits (optional), followed by R, C, H, M or MF, Followed by 2 or 3 digits (optional), followed by any alphanumeric digit (optional)	Incomplete Motor Parts
SM01 , SM01, Followed by 2 digits, Followed by "x" or "Sx", Followed by 2 or 3 digits, Followed by "-", "F", "H" or "G", Followed by HP, Followed by R, C, H, M or MF, Followed by 2 or 3 digits (Optional), Followed by 2 or 3 digits, Followed by "BE" plus 2 digits (Optional), Followed by "MS" plus 2 digits (Optional), Followed by "EN" plus 2 digits (Optional), Followed by "FS" plus 2 digits (Optional), Followed by "BK" plus 2 digits (Optional), Followed by SSCP, followed by "-" or any alphanumeric digit.	Incomplete Motor Parts
SM02 , SM02, Followed by 2 digits, Followed by "x" or "Sx", Followed by 2 or 3 digits, Followed by "-", "F", "H" or "G", Followed by HP, Followed by R, C, H, M or MF, Followed by 2 or 3 digits (Optional), Followed by 2 or 3 digits, Followed by "BE" plus 2 digits (Optional), Followed by "MS" plus 2 digits (Optional), Followed by "EN" plus 2 digits (Optional), Followed by "FS" plus 2 digits (Optional), Followed by "BK" plus 2 digits (Optional), Followed by SSCP, followed by "-" or any alphanumeric digit.	Incomplete Motor Parts

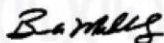

Bruce Mahrenholz, Director North American Certification Program

UL LLC

Any information and documentation involving UL Mark services are provided on behalf of UL LLC (UL) or any authorized licensee of UL. For questions, please contact a local UL Customer Service Representative at <http://ul.com/aboutul/locations/>



10 EU Declaration of Conformity CE-Marking

NTI AG / LinMot®
Bodenaeckerstrasse 2
8957 Spreitenbach

Switzerland

Tel.: +41 (0)56 419 91 91

Fax: +41 (0)56 419 91 92

declares under sole responsibility the compliance of the products:

- Linear Motors of the Series **PS01-48 SSCP**

with the EMC Directive 2014/30/EU.

Applied harmonized standards:

- **EN 61000-6-2: 2005 (Immunity for industrial environments)**
- **EN 61000-6-4: 2007 + A1: 2011 (Emission for industrial environments)**

According to the EMC directive, the listed devices are not independently operable products.

Compliance of the directive requires the correct installation of the product, the observance of specific installation guides and product documentation. This was tested on specific system configurations.

The safety instructions of the manuals are to be considered.

The product must be mounted and used in strict accordance with the installation instructions contained within the installation guide, a copy of which may be obtained from NTI AG.

Company: NTI AG
Spreitenbach, 02.08.2024



Dr.-Ing. Ronald Rohner
CEO NTI AG

11 UK Declaration of Conformity UKCA-Marking

NTI AG / LinMot®
Bodenaeckerstrasse 2
8957 Spreitenbach

Switzerland

Tel.: +41 (0)56 419 91 91

Fax: +41 (0)56 419 91 92

declares under sole responsibility the compliance of the products:

- Linear Motors of the Series **PS01-48 SSCP**

with the EMC Regulation S.I. 2016 No. 1091.

Applied designated standards:

- **EN 61000-6-2: 2005 (Immunity for industrial environments)**
- **EN 61000-6-4: 2007 + A1: 2011 (Emission for industrial environments)**

According to the EMC regulation, the listed devices are not independently operable products.

Compliance of the regulation requires the correct installation of the product, the observance of specific installation guides and product documentation. This was tested on specific system configurations.

The safety instructions of the manuals are to be considered.

The product must be mounted and used in strict accordance with the installation instructions contained within the installation guide, a copy of which may be obtained from NTI AG.

Company: NTI AG
Spreitenbach, 02.08.2024



Dr.-Ing. Ronald Rohner
CEO NTI AG

ALL LINEAR MOTION FROM A SINGLE SOURCE

Europe / Asia Headquarters

NTI AG - LinMot & MagSpring

Bodenaeckerstrasse 2
CH-8957 Spreitenbach

Sales / Administration: T +41-(0)56-419 91 91
F +41-(0)56-419 91 92
office@linmot.com

Tech. Support: +41-(0)56-544 71 00
support@linmot.com

Web: <http://www.linmot.com/>

North / South America Headquarters

LinMot USA, Inc.

N1922 State Road 120, Unit 1
Lake Geneva, WI 53147

Sales / Administration : 262-743-2555
usasales@linmot.com

Tech. Support: usasupport@linmot.com

Web: <http://www.linmot.com/>

Visit <http://www.linmot.com/> to find a distributor next to you.