

Installation Guide Linear Motors

ENG

P01-23-HP-SSCP



Content

1	General Information	4
1.1	Introduction	4
1.2	Explanation of Symbols	4
1.3	Qualified Personnel	4
1.4	Liability	4
1.5	Copyright	4
2	Safety Instructions	5
3	Installation Instructions	7
3.1	Operating Conditions	7
3.2	Assembly of the Linear Motor	7
3.3	Mounting the Stator	8
3.3.1	Vertical Mounting of the Stator	8
3.3.2	Horizontal Stator Mounting	9
3.4	Mounting the Payload to the Slider	9
3.5	"Moving Slider" Installation	10
3.6	Minimum distance from slider	11
3.6.1	Minimum distance from slider to slider	11
3.6.2	Minimum distance from slider to metallic parts	11
3.7	Material Data	12
4	Electrical connection	13
4.1	Motor Cable	13
4.1.1	Technical Data of the Stator Cable	13
4.1.2	Technical Data of Extension Cables	14
4.1.3	Cable Installation	14
4.2	Connectors	14
4.2.1	IP Class IP67	14
4.2.2	IP Class IP69k	15
4.2.3	Pin Assignment Linear Motor	15
5	Accessories	16
5.1	Motor Cables	16
5.2	Slider Mounting Kits	18
5.2.1	Fixed Bearing	18
6	Maintenance and test instructions	19
6.1	Stator Checking	19
6.2	Maintenance of Linear Motors	21
6.2.1	Maintenance Schedule	21
6.2.2	Cleaning	21
6.2.3	Cleaning Agent / Lubricant	21
7	«Wash-Down» Advice	21
8	Storage, Transport, Installation Altitude	22
9	Dimensions	22
9.1	Stator	22

9.1.1	PS01-23x80F-HP-SSCP-R20.....	22
9.1.2	PS01-23x80F-HP-SSCP-G02-R20.....	23
9.1.3	PS01-23x80F-HP-SSCP-R150.....	23
9.1.4	PS01-23x80F-HP-SSCP-G02-R150.....	24
9.1.5	PS01-23x160H-HP-SSCP-R20.....	24
9.1.6	PS01-23x160H-HP-SSCP-G02-R20.....	25
9.1.7	PS01-23x160H-HP-SSCP-R150.....	25
9.1.8	PS01-23x160H-HP-SSCP-G02-R150.....	26
9.2	Sliders.....	26
9.2.1	Sliders HP / Heavy Duty HP / HCR.....	26
9.2.2	Hollow Sliders HP.....	28
10	International Certificates.....	29
11	EU Declaration of Conformity CE-Marking.....	35
12	UK Declaration of Conformity UKCA-Marking.....	36

1 General Information

1.1 Introduction

This manual includes instructions for the assembly, installation, maintenance, transport, and storage of linear motors. The document is intended for electricians, mechanics, service technicians, and warehouse staff. Read this manual before using the product and observe the general safety instructions and those in the relevant section at all times.

Keep these operating instructions in an accessible place and make them available to the personnel assigned.

1.2 Explanation of Symbols



Triangular warning signs warn of danger.



Round command symbols tell what to do.

1.3 Qualified Personnel

All work such as installation, commissioning, operation and service of the product may only be carried out by qualified personnel.

The personnel must have the necessary qualifications for the corresponding activity and be familiar with the installation, commissioning, operation and service of the product. The manual and in particular the safety instructions must be carefully read, understood and observed.

1.4 Liability

NTI AG (as manufacturer of LinMot and MagSpring products) excludes all liability for damages and expenses caused by incorrect use of the products. This also applies to false applications, which are caused by NTI AG's own data and notes, for example in the course of sales, support or application activities. It is the responsibility of the user to check the data and information provided by NTI AG for correct applicability in terms of safety. In addition, the entire responsibility for safety-related product functionality lies exclusively with the user. Product warranties are void if products are used with stators, sliders, servo drives or cables not manufactured by NTI AG unless such use was specifically approved by NTI AG.

NTI AG's warranty is limited to repair or replacement as stated in our standard warranty policy as described in our "terms and conditions" previously supplied to the purchaser of our equipment (please request copy of same if not otherwise available). Further reference is made to our general terms and conditions.

1.5 Copyright

This work is protected by copyright.

Under the copyright laws, this publication may not be reproduced or transmitted in any form, electronic or mechanical, including photocopying, recording, microfilm, storing in an information retrieval system, not even for training purposes, or translating, in whole or in part, without the prior written consent of NTI AG.

LinMot® and MagSpring® are registered trademarks of NTI AG.

2 Safety Instructions



Contusions

Sliders contain neodymium magnets and have a strong attractive force. Careless handling could cause fingers or skin to become pinched between two sliders. This may lead to contusions, bruises, and bone fractures. When handling sliders, wear thick protective gloves and keep a minimum distance between sliders. Refer to the "Minimum distance from slider" section for minimum distance.

To reduce the risk of injury, never more than one slider should be held or transported by the same person without packaging.



Pacemaker / Implanted Heart Defibrillator

Sliders could affect the functioning of pacemakers and implanted heart defibrillators. For the duration of a strong approach to a magnetic field, these devices switch into test mode and will not function properly.

- If you wear one of those devices keep the following minimum distances between the pacemaker / defibrillator and slider:
 - Min. 250 mm (10") for slider Ø 27 mm and 28 mm (PL01-27 / 28 / PL10-28)
 - Min. 150 mm (6") for slider Ø 19 mm and 20 mm (PL01-19 / 20)
 - Min. 100 mm (4") for slider Ø 12 mm (PL01-12)
- Inform others who wear these devices to comply with these minimum distances!



Caution - Risk of Electric Shock !

Before working, make sure that there are no high voltages.



Fast-moving Machine Parts

The sliders of LinMot linear motors are fast-moving machine parts. All necessary precautions must be taken to prevent persons approaching the moving elements during operation (provide covers, guards, etc.).



Automatic Restart

The motors can start automatically under certain circumstances! If necessary, a corresponding warning symbol must be provided and protection against entering the hazardous area or a suitable safe electronic disconnection must be provided!



Risk of Injury due to a Defect or Fault

For areas where a defect or fault can result in substantial property damage or even serious personal injury, additional external precautions must be taken or devices must be installed to ensure safe operation even if a defect or fault occurs (eg. suitable safe electronic disconnection, mechanical interlocks, barriers, etc.).



Magnetic Field

Magnets integrated in the sliders produce a strong magnetic field. They could damage TVs, laptops, computer hard drives, credit and ATM cards, data storage media, mechanical watches, hearing aids, and speakers.

- Keep magnets away from devices and objects that could be damaged by strong magnetic fields.
- For the above mentioned objects, keep a minimum distance as described in the "Pacemaker / implanted defibrillator" section.
- For non-anti-magnetic watches, keep the double minimum distance.

**Combustibility**

When machining magnets, the drilling dust could easily ignite. Machining the sliders and the magnets they contain is not permitted.

**Burn Hazard**

During operation the slider can become hotter than 100 °C, which can cause burns if touched. All necessary precautions (e.g. covers, casing, etc.) must be taken to prevent contact with persons in the vicinity of the slider during operation.

**Grounding**

All metal parts that are exposed to contact during any user operation or servicing and likely to become energized shall be reliably connected to the means for grounding.

**Mechanical Handling**

Neodymium magnets are brittle and heat-sensitive. Machining the sliders and the magnets they contain is not permitted.

- Colliding magnets could crack. Sharp splinters could be catapulted for several meters and cause eye injury.
- By machining the sliders, heat would result which demagnetizes the magnets.

**Slider**

Linear motor sliders consist of a high-precision, thin-walled stainless steel tube in which the neodymium magnets are housed. The LinMot sliders should be handled with care. Avoid contact with other sliders or iron parts as this can damage the magnets and the slider surface. Do not grip the sliders with pliers, as this can also damage the surface. Do not use sliders which are already damaged on the surface (scratches, deformation, etc.). This can cause further damage to the stator.

**Effects on People**

According to the current level of knowledge, magnetic fields of permanent magnets do not have a measurable positive or negative effect on people. It is unlikely that permanent magnets constitute a health risk, but it cannot be ruled out entirely.

- For your own safety, avoid constant contact with magnets.
- Store large magnets at least one meter away from your body.

**Temperature Resistance**

Keep slider away from unshielded flame or heat. Temperature above 120°C will cause demagnetization.

3 Installation Instructions

3.1 Operating Conditions



- Maximum ambient temperature limits: 0 °C¹⁾...80 °C
- Internal temperature sensor error occurs at: 120 °C
- The motors must not be operated under water.

¹⁾ Lower temperatures on request.

3.2 Assembly of the Linear Motor



Please attend to the safety instructions in chapter 2 during the assembling!

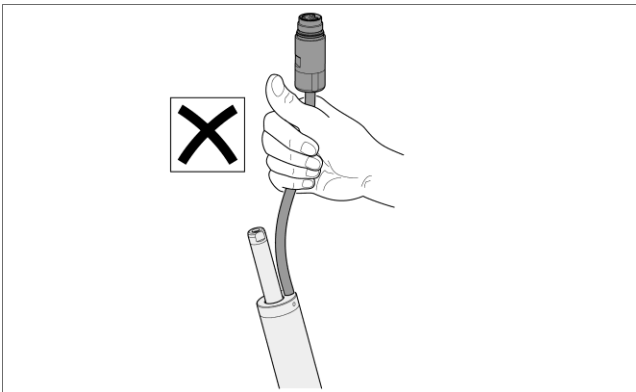

Do not hold the stator by the cable during handling. The tensile strength of the cable is only 10 N.

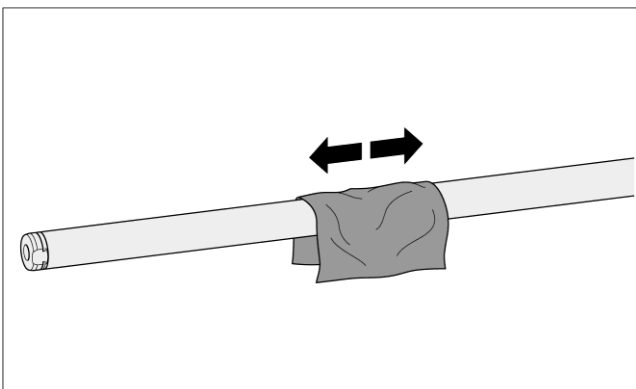

1. Clean the slider with a paper towel.

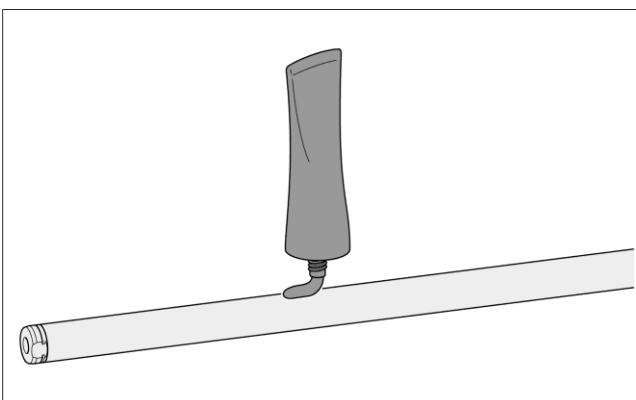

2. Lubricate the slider.

Sliders with a length of more than 500 mm are lubricated with a grease quantity of 4 g (approx. ½ hazelnut) per meter. Shorter sliders are inserted without lubrication. The grease can be applied by hand or with a soft paper towel.



Always observe the specified grease quantity. Over lubrication leads to a gumming of the grease, which appears particularly at higher operating temperatures!

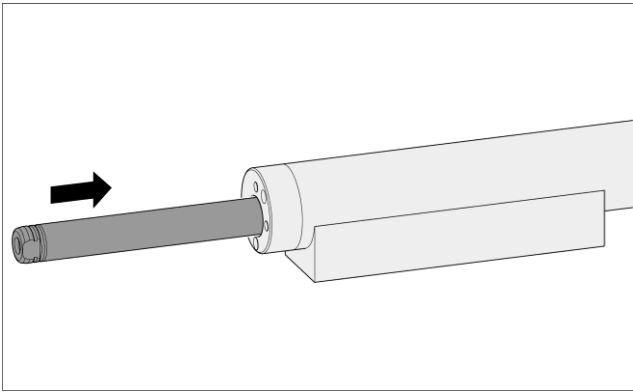

3. Insert the slider in the defined direction (see next assembly step).



Large magnetic attraction forces
(Observe warning notice from page 5)!
If necessary, cover obvious iron constructions
with non-magnetic material (e.g. wood).



Observe excentric stator bore during
assembly.
See dimensions in chapter 9.

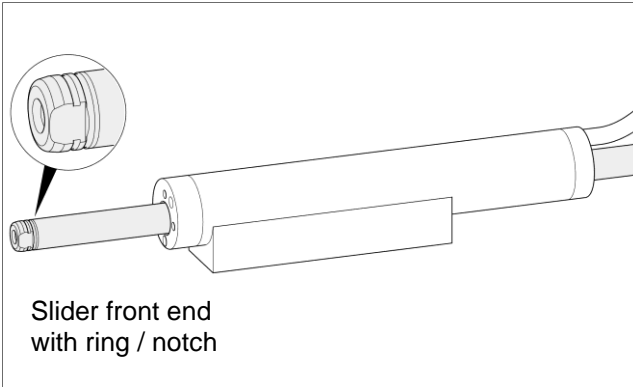

4. **Checking the installed direction of slider**
After the installation, the front end of the slider
is located at the opposite side of the stator from
the cable connector or cable exit.

3.3 Mounting the Stator

The stator can be mounted vertically and horizontally using the threaded holes provided. Both mounting options are shown below.

3.3.1 Vertical Mounting of the Stator

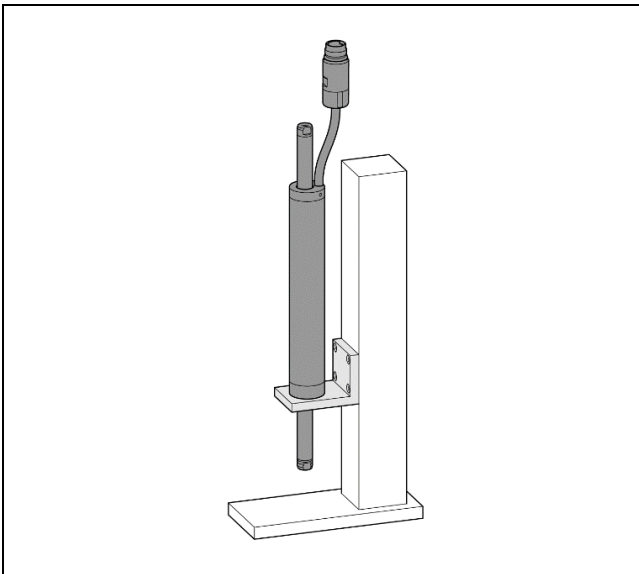

Mounting using the threaded holes on the front
side. See thread details in chapter 9 "Dimensions".

3.3.2 Horizontal Stator Mounting

The G02 stator variant, which has an integrated mounting flange, can be mounted horizontally. In this case, the stator is aligned flat and screwed to the base using the threaded holes on the underside. The positions of the threaded holes are shown in chapter 9 "Dimensions".

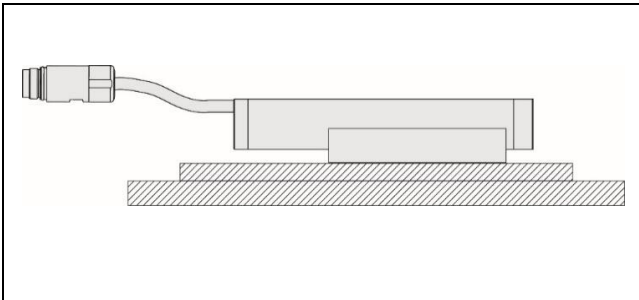

- For optimum motor cooling it is important that the complete mounting flange is in contact with the surface.
- Max. torque must be observed

Thread	Max. torque for screw
M4	2 Nm

3.4 Mounting the Payload to the Slider

The load is mounted as a fixed bearing using spherical washers and conical seats (see the section «Slider mounting kits»).



To avoid shear force on slider and wear on stator, the payload has to be beared by a linear guide.

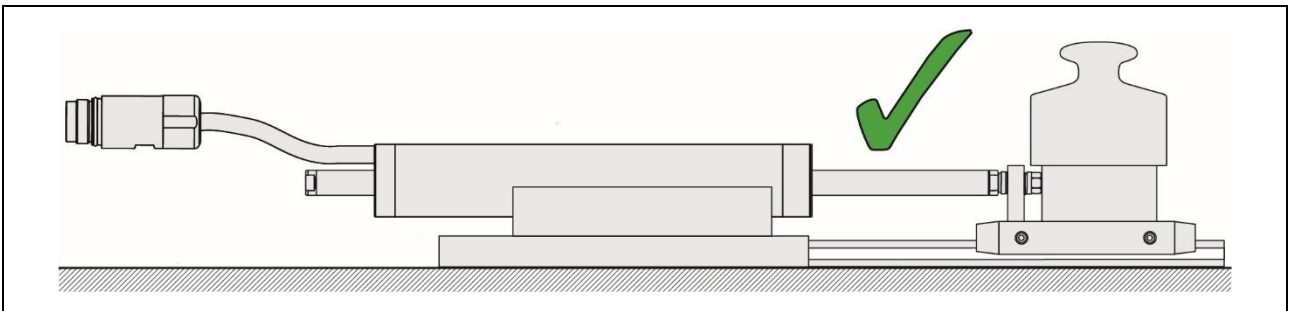
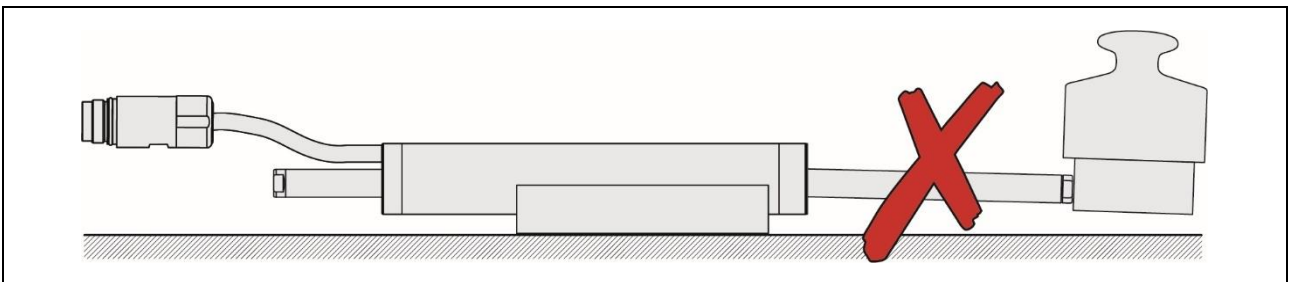

When attaching the load, the wrench for tightening the load must be used only on the load-facing side of the slider. Avoid torsional stress on slider (note the following figures).



! Incorrect Mounting
Torsional stress on slider!

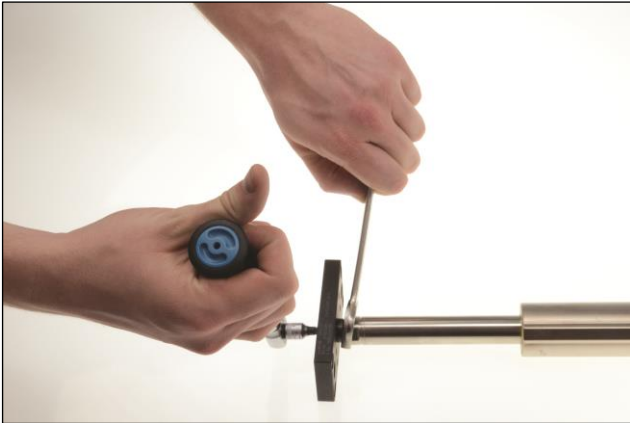

Correct Mounting

Slider	Thread	Max. torque for screw (Stainless steel A4)
12 mm	M5	3.8 Nm

3.5 "Moving Slider" Installation

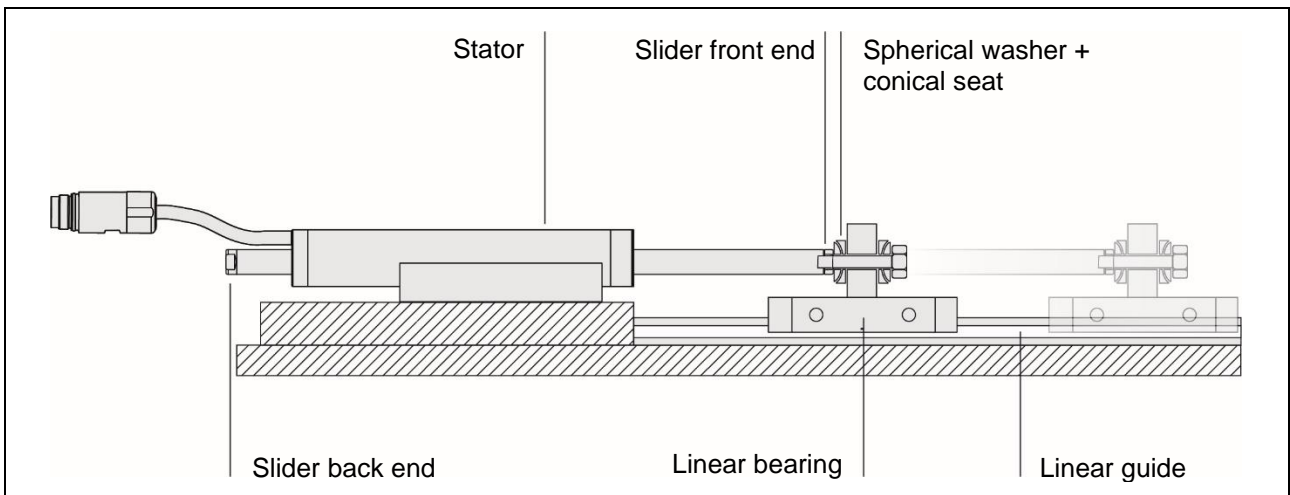

In a "moving slider" installation, the stator is fixed and the slider is the moving part. The load, borne by a linear guide, is attached directly to the end of the slider. In order to compensate for misalignment, spherical axial bearings consisting of spherical washers and conical seats (see the section Slider mounting kits) are used to connect to the load. The mounting kit of slider and an oversized hole for the screw make it possible to adjust a radial and angle offset.



If a mechanical end stop at the back end of the slider is required, make sure that the stator cable is not kinked during operation.

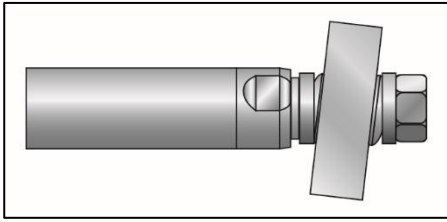

Mounted payload with radial and angle offset.

3.6 Minimum distance from slider

3.6.1 Minimum distance from slider to slider

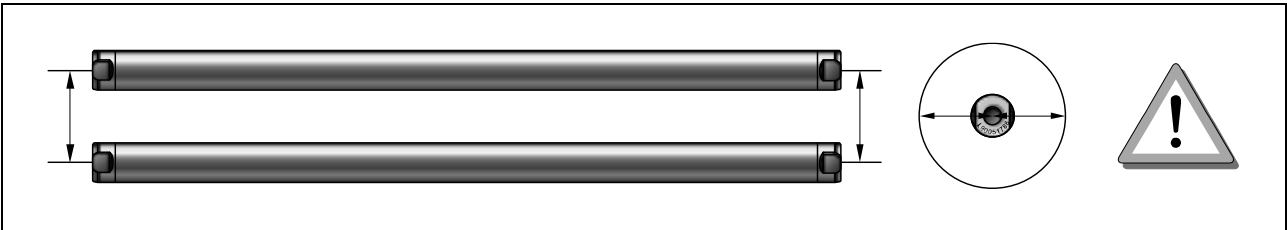

The sliders are made of neodymium magnets and have a strong magnetic attraction. It must be kept a minimum distance between the sliders. This minimized the risk of bruising and secondly, the sliders do not influence each other through their magnetic fields.

Type of slider	PL01	PL01-20 / PL01-19	PL01-28 / PL01-27	PL10-28
PL01-12	30 mm (1.18 in)			
PL01-20 / PL01-19		50 mm (1.97 in)		
PL01-28 / PL01-27			80 mm (3.15 in)	
PL10-28				70 mm (2.76 in)

The data are measured from slider center to slider center.

3.6.2 Minimum distance from slider to metallic parts

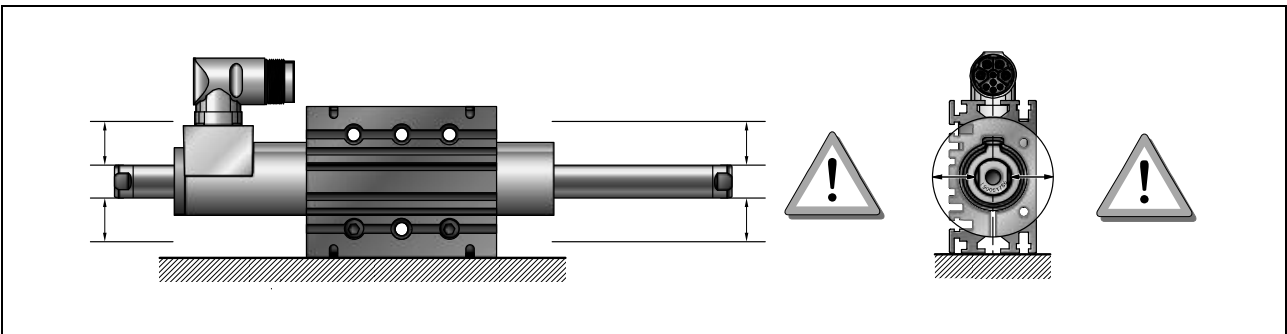

When installing linear motors in modules with metal parts near the slider, undesired forces can arise due to magnetic attraction or eddy currents. These generally manifest as erratic and jerky positioning, or reduced dynamics of the linear motor. In order to avoid this, minimum distances between the slider and any metal parts are to be observed whenever metal materials are used nearby.

Linear Motor	Minimum distance from slider surface to ferromagnetic parts (iron, steel, etc.)	Minimum distance from slider surface to non-ferromagnetic metallic parts (aluminum, bronze, stainless steel, etc.)
P01-23x...	10 mm	5 mm

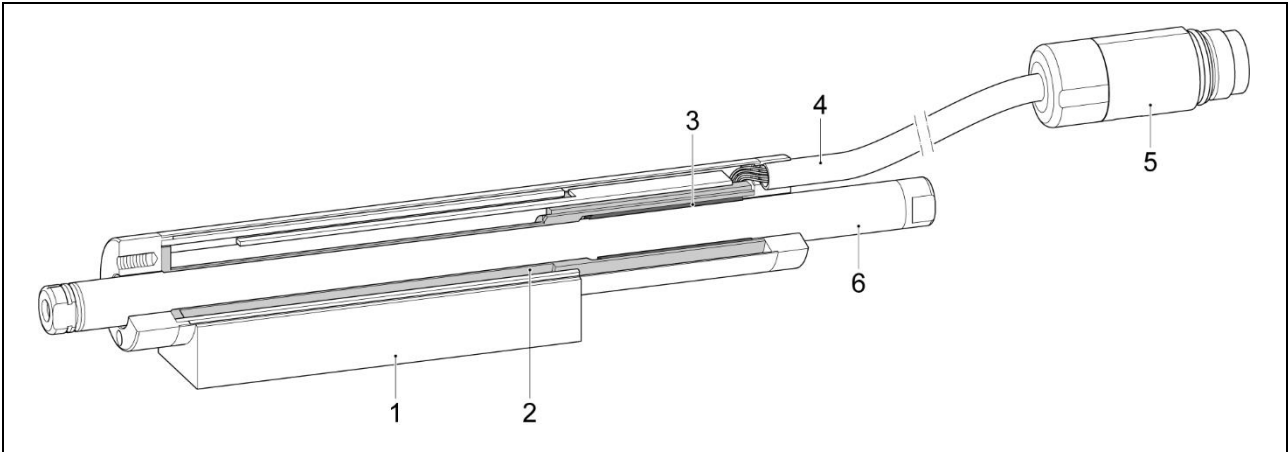
3.7 Material Data

Pos.	Component	Material
1	Stator-Housing / Flange	Stainless steel 1.4404 / AISI 316L
2	Bearing tube	PEEK
3	Bearing sleeve	PPS
4	Cable sheath	PUR
5	Stator connector housing (Statorvariant ...R20)	Stainless steel 1.4404 / AISI 316L
	Stator connector housing (Statorvariant ...R150)	Steel nickel-plated
6	Slider tube HP Standard	Stainless steel 1.4301 / AISI 304
	Slider tube HP HCR	Stainless steel 1.4404 / AISI 316L

4 Electrical connection

4.1 Motor Cable



Do not connect or disconnect motor when there is power on the servo drive. Use only double-shielded original LinMot cable. Cables from other sources must be checked precisely before commissioning. Incorrect connections can destroy the drive and stator.



The stator is connected to protective earth via the motor cable. The screw connections of R connector must be tightened up to the stop. Three types of cables are available for linear motors. The standard motor cable is intended for stationary installation. The High-Flex cable (suitable for trailing chains) and the robot cable are used for moving cable applications. The connector cable integrated in the stator is 20 cm or 150 cm (R20 or R150) long depending on the stator variant and must not be moved.

4.1.1 Technical Data of the Stator Cable

	PS01-23x80F-HP-SSCP-R20 PS01-23x160H-HP-SSCP-R20	PS01-23x80F-HP-SSCP-R150 PS01-23x160H-HP-SSCP-R150
Cable name	KS03-09	
Cable length	200 mm	1500 mm
Minimum bending radius for fixed installation	25 mm (0.98 in)	
Minimum bending radius when moving	Not suitable for applications with moving motor cable.	
Approval	UL / CSA 300V	
Material wire insulation	TPE-E	
Material cable sheath	PUR	
Permissible temperature	-40 °C...+80 °C	
Oil resistance	very good acc. DIN VDE 0282 Part 10 + HD 22.10	
Chemical resistance (to acids, alkalis, solvents, hydraulic fluid)	good	

4.1.2 Technical Data of Extension Cables

	Standard cable	High-Flex cable	Robot cable
Cable name	K05-04/05	KS05-04/05	KR05-04/05
Minimum bending radius for fixed installation	25 mm (1 in)	30 mm (1.2 in)	40 mm (1.6 in)
Minimum bending radius when moving	Not suitable for applications with moving motor cable.	60 mm (2.4 in) No Torsion	80 mm (3.2 in) Max.Torsion: ±270° pro 0.5 m
Approval	UL / CSA 300V	UL / CSA 300V	UL / CSA 300V
Material wire insulation	TPE-U	TPE-E	TPE-E
Material cable sheath	PUR	PUR	PUR
Oil resistance	very good acc. DIN VDE 0282 Part 10 + HD 22.10	very good acc. DIN VDE 0282 Part 10 + HD 22.10	very good acc. DIN VDE 0282 Part 10 + HD 22.10
Chemical resistance (to acids, alkalis, solvents, hydraulic fluid)	good	good	good

4.1.3 Cable Installation

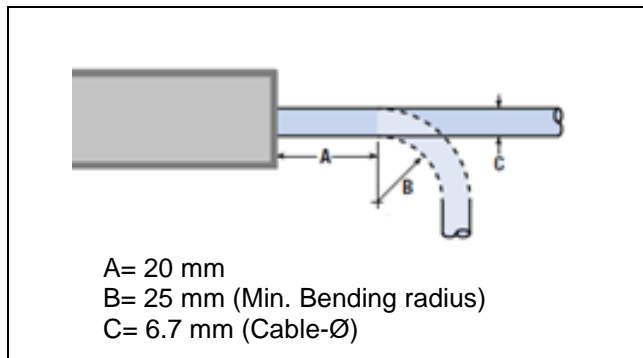

The stator cable must not be laid in a freely movable manner. The cable must be laid firmly, observing minimum bending radius for fixed installation (see chapter 4.1.1). If free movement of the cable is desired, an extension cable should be provided.

Max. tensile force 10 N of the stator cable!

4.2 Connectors

Depending on the stator variant, 2 different types of motor connectors or cable connectors are available. For the stators with the suffix R150 the connectors are designed with protection class IP67 and for the R20 stators with protection class IP69K. Motor connector and cable connector are screwed together tightly. Dimensions and tightening torque are shown in the following illustrations.

4.2.1 IP Class IP67

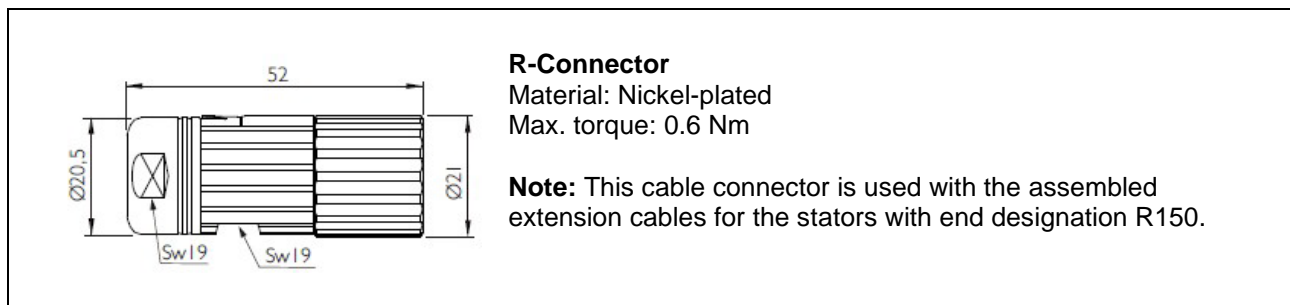

Ordering information

Item	Description	Item-No.
MC01-R/f	Motor connector R/f	0150-3129

4.2.2 IP Class IP69k

R-Connector
 Material: Stainless steel (1.4404)
 Max. torque: 0.6 Nm

Note: This cable connector is used with the assembled extension cables for the stators with end designation R20.

Ordering information

Item	Description	Item-No.
MC01-R/f-IP69K-SSC	Motor connector R/f, IP69k, SSC	0150-3347

4.2.3 Pin Assignment Linear Motor



Do not connect or disconnect motor when there is power on the servo drive. Use only double-shielded original LinMot cable. Cables from other sources must be checked precisely before commissioning. Incorrect connections can destroy the drive and stator.

Connector Type	R-Connector
	Pin
Phase1+	1
Phase1-	2
Phase2+	3
Phase2-	4
+5V	A
SIGNAL-GROUND*	B
Sensor Sin	C
Sensor Cos	D
Temp sensor	E
SHIELD** of stator and stator cable	Case
Connector on the stator (-cables)	



Extension cables are double shielded. The two shields of the extension cables must not be connected together: the inner shield of the extension cables is used as GROUND and must be connected to SIGNAL-GROUND*; only the outer shield must be connected to SHIELD** of the connector.

5 Accessories

5.1 Motor Cables

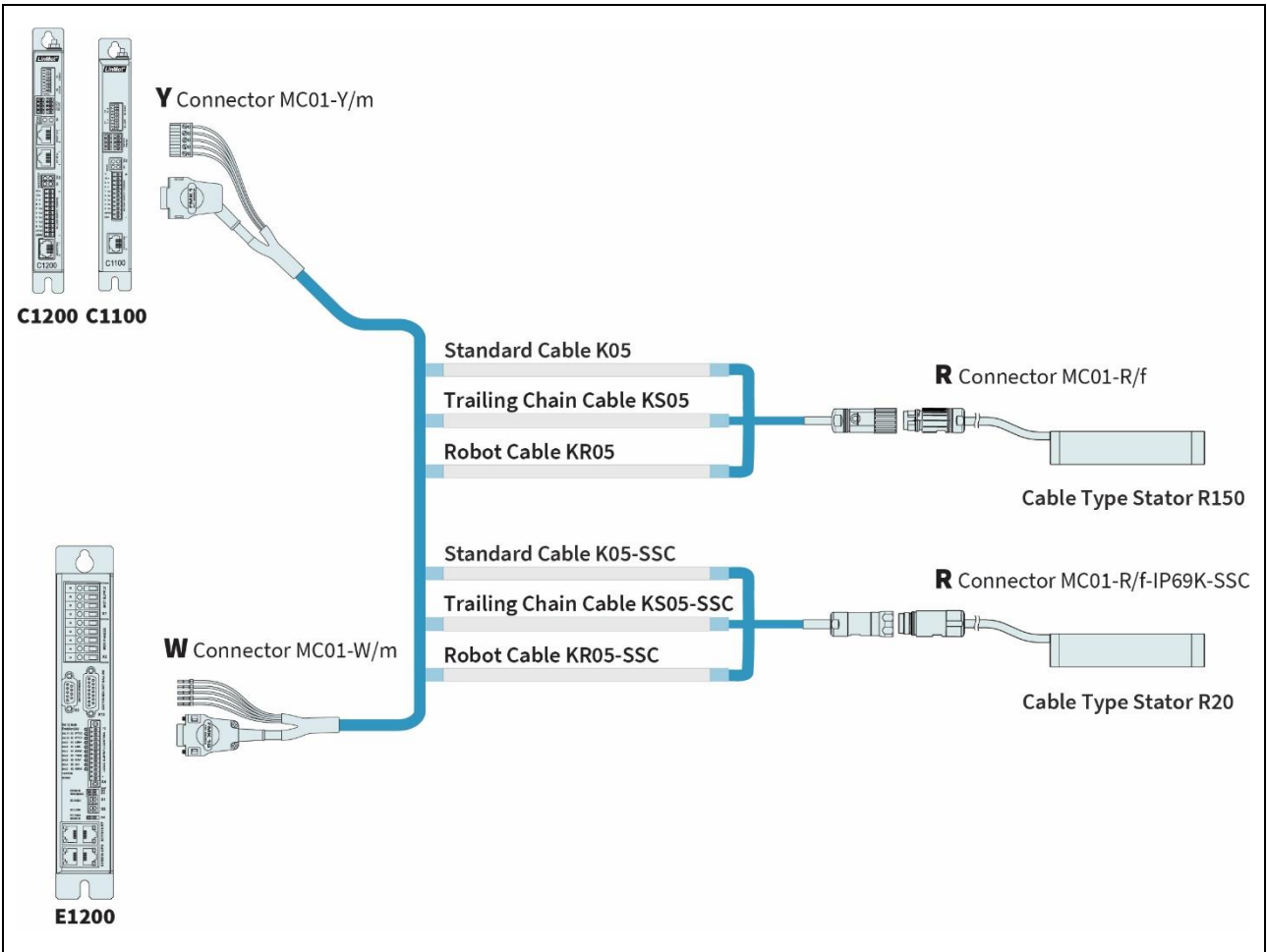

Item	Description	Item-No.
K05-W/R-2	Motor Cable W/R, 2 m	0150-2119
K05-W/R-4	Motor Cable W/R, 4 m	0150-2120
K05-W/R-6	Motor Cable W/R, 6 m	0150-2121
K05-W/R-8	Motor Cable W/R, 8 m	0150-2122
K05-W/R-	Motor Cable W/R, Custom length	0150-3262
K05-Y/R-2	Motor Cable Y/R, 2 m	0150-2421
K05-Y/R-4	Motor Cable Y/R, 4 m	0150-2422
K05-Y/R-6	Motor Cable Y/R, 6 m	0150-2423
K05-Y/R-8	Motor Cable Y/R, 8 m	0150-2424
K05-Y-Fe/R-	Motor Cable Y/R, Custom length	0150-3501
K05-W/R-SSC-	Motor Cable W/R-SSC, Custom length	0150-3586

K05-Y-Fe/R-SSC-	Motor Cable Y-Fe/R-SSC, Custom length	0150-3715
-----------------	---------------------------------------	-----------

Item	Description	Item-No.
KS05-W/R-4	Trailing Chain Cable W/R, 4 m	0150-2106
KS05-W/R-6	Trailing Chain Cable W/R, 6 m	0150-2131
KS05-W/R-8	Trailing Chain Cable W/R, 8 m	0150-2107
KS05-W/R-	Trailing Chain Cable W/R, Custom length	0150-3256
KS05-Y/R-2	Trailing Chain Cable Y/R, 2 m	0150-4165
KS05-Y/R-4	Trailing Chain Cable Y/R, 4 m	0150-2433
KS05-Y/R-6	Trailing Chain Cable Y/R, 6 m	0150-2434
KS05-Y/R-8	Trailing Chain Cable Y/R, 8 m	0150-2435
KS05-Y-Fe/R-	Trailing Chain Cable Y-Fe/R, Custom length	0150-3507
KS05-W/R-SSC-2	Trailing Chain Cable W/R-SSC, 2 m	0150-2683
KS05-W/R-SSC-4	Trailing Chain Cable W/R-SSC, 4 m	0150-2684
KS05-W/R-SSC-6	Trailing Chain Cable W/R-SSC, 6 m	0150-2685
KS05-W/R-SSC-8	Trailing Chain Cable W/R-SSC, 8 m	0150-2686
KS05-W/R-SSC-	Trailing Chain Cable W/R-SSC, Custom length	0150-3583
KS05-Y/R-SSC-2	Trailing Chain Cable Y/R-SSC, 2 m	0150-2687
KS05-Y/R-SSC-4	Trailing Chain Cable Y/R-SSC, 4 m	0150-2688
KS05-Y/R-SSC-6	Trailing Chain Cable Y/R-SSC, 6 m	0150-2689
KS05-Y/R-SSC-8	Trailing Chain Cable Y/R-SSC, 8 m	0150-2690
KS05-Y-Fe/R-SSC-	Trailing Chain Cable Y-Fe/R-SSC, Custom length	0150-3646

Item	Description	Item-No.
KR05-W/R-	Robot Cable KR05-W/R, Custom length	0150-3336
KR05-Y-Fe/R-	Robot Cable KR05-Y-Fe/R, Custom length	0150-3512
KR05-W/R-SSC-	Robot Cable KR05-W/R-SSC-, Custom length	0150-3587
KR05-Y-Fe/R-SSC-	Robot Cable KR05-Y-Fe/R-SSC-, Custom length	0150-4364

Item	Description	Item-No.
MC01-W/m	Motor Connector W/m	0150-3140
MC01-Y-Fe/m	Motor Connector Y-Fe/m	0150-3289
MC01-R/f	Motor Connector R/f	0150-3129
MC01-R/f-IP69K-SSC	Motor Connector R/f, IP69k, SSC	0150-3347
K05-04/05	Motor Cable per m	0150-1920
KS05-04/05	Trailing Chain Cable per m	0150-1938
KR05-04/05	Robot Cable per m	0150-1846

5.2 Slider Mounting Kits

5.2.1 Fixed Bearing

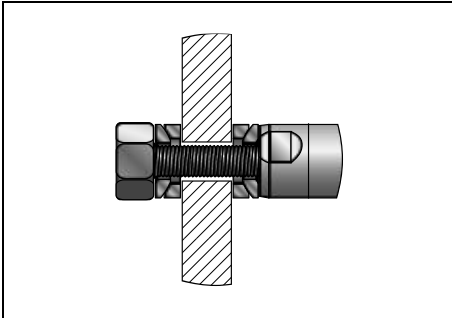

Slider mounting kit consists of a spring washer, a pair of spherical washers, and a pair of conical seats. It allows the slider to be fixed in the direction of motion. It also helps to compensate for radial and angle offset.

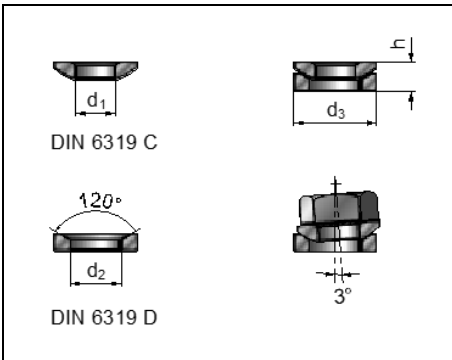

Material

Spherical washer / conical seat: case hardened steel

Item	Item No.	Slider	Thread	d1	d2	d3	h
PLF01-12-Ni (Nickel-plated)	0150-3573	12mm	M5	5.2mm (0.20in)	6.0mm (0.24in)	10.5mm (0.41in)	3.2mm (0.13in)

6 Maintenance and test instructions

6.1 Stator Checking

The following tables show the resistive value between the different connector pins for each stator type. If the value is not within a range of +/- 10% the stator may be damaged (temperature of the stator for all measurements: 20°C).

PS01-23x80F-HP-SSCP-R150 (0150-4379)

Phase1+ / Phase1-	Red / Orange	Pin 1 / Pin 2	4.2 Ω
Phase2+ / Phase2-	Blue / Gray	Pin 3 / Pin 4	4.2 Ω
5V / GND	White / Brown	Pin A / Pin B	505 Ω
Sensor Sine / GND	Yellow / Brown	Pin C / Pin B	37.5 kΩ
Sensor Cosine / GND	Green / Brown	Pin D / Pin B	37.5 kΩ
Temp. Sensor / GND	Black / Brown	Pin E / Pin B	10 kΩ
Phase / GND	-	Pin 1,2,3,4 / Pin B	>20 MΩ
All Pin / Shield	-	Pin 1-E / Housing	>20 MΩ

PS01-23x80F-HP-SSCP-G02-R150 (0150-4471)

Phase1+ / Phase1-	Red / Orange	Pin 1 / Pin 2	4.2 Ω
Phase2+ / Phase2-	Blue / Gray	Pin 3 / Pin 4	4.2 Ω
5V / GND	White / Brown	Pin A / Pin B	505 Ω
Sensor Sine / GND	Yellow / Brown	Pin C / Pin B	37.5 kΩ
Sensor Cosine / GND	Green / Brown	Pin D / Pin B	37.5 kΩ
Temp. Sensor / GND	Black / Brown	Pin E / Pin B	10 kΩ
Phase / GND	-	Pin 1,2,3,4 / Pin B	>20 MΩ
All Pin / Shield	-	Pin 1-E / Housing	>20 MΩ

PS01-23x80F-HP-SSCP-R20 (0150-4359)

Phase1+ / Phase1-	Red / Orange	Pin 1 / Pin 2	4.2 Ω
Phase2+ / Phase2-	Blue / Gray	Pin 3 / Pin 4	4.2 Ω
5V / GND	White / Brown	Pin A / Pin B	505 Ω
Sensor Sine / GND	Yellow / Brown	Pin C / Pin B	37.5 kΩ
Sensor Cosine / GND	Green / Brown	Pin D / Pin B	37.5 kΩ
Temp. Sensor / GND	Black / Brown	Pin E / Pin B	10 kΩ
Phase / GND	-	Pin 1,2,3,4 / Pin B	>20 MΩ
All Pin / Shield	-	Pin 1-E / Housing	>20 MΩ

PS01-23x80F-HP-SSCP-G02-R20 (0150-4472)

Phase1+ / Phase1-	Red / Orange	Pin 1 / Pin 2	4.2 Ω
Phase2+ / Phase2-	Blue / Gray	Pin 3 / Pin 4	4.2 Ω
5V / GND	White / Brown	Pin A / Pin B	505 Ω
Sensor Sine / GND	Yellow / Brown	Pin C / Pin B	37.5 kΩ
Sensor Cosine / GND	Green / Brown	Pin D / Pin B	37.5 kΩ
Temp. Sensor / GND	Black / Brown	Pin E / Pin B	10 kΩ
Phase / GND	-	Pin 1,2,3,4 / Pin B	>20 MΩ
All Pin / Shield	-	Pin 1-E / Housing	>20 MΩ

PS01-23x160H-HP-SSCP-R150 (0150-4380)

Phase1+ / Phase1-	Red / Orange	Pin 1 / Pin 2	3.9 Ω
Phase2+ / Phase2-	Blue / Gray	Pin 3 / Pin 4	3.9 Ω
5V / GND	White / Brown	Pin A / Pin B	505 Ω
Sensor Sine / GND	Yellow / Brown	Pin C / Pin B	37.5 k Ω
Sensor Cosine / GND	Green / Brown	Pin D / Pin B	37.5 k Ω
Temp. Sensor / GND	Black / Brown	Pin E / Pin B	10 k Ω
Phase / GND	-	Pin 1,2,3,4 / Pin B	>20 M Ω
All Pin / Shield	-	Pin 1-E / Housing	>20 M Ω

PS01-23x160H-HP-SSCP-G02-R150 (0150-4473)

Phase1+ / Phase1-	Red / Orange	Pin 1 / Pin 2	3.9 Ω
Phase2+ / Phase2-	Blue / Gray	Pin 3 / Pin 4	3.9 Ω
5V / GND	White / Brown	Pin A / Pin B	505 Ω
Sensor Sine / GND	Yellow / Brown	Pin C / Pin B	37.5 k Ω
Sensor Cosine / GND	Green / Brown	Pin D / Pin B	37.5 k Ω
Temp. Sensor / GND	Black / Brown	Pin E / Pin B	10 k Ω
Phase / GND	-	Pin 1,2,3,4 / Pin B	>20 M Ω
All Pin / Shield	-	Pin 1-E / Housing	>20 M Ω

PS01-23x160H-HP-SSCP-R20 (0150-4381)

Phase1+ / Phase1-	Red / Orange	Pin 1 / Pin 2	3.9 Ω
Phase2+ / Phase2-	Blue / Gray	Pin 3 / Pin 4	3.9 Ω
5V / GND	White / Brown	Pin A / Pin B	505 Ω
Sensor Sine / GND	Yellow / Brown	Pin C / Pin B	37.5 k Ω
Sensor Cosine / GND	Green / Brown	Pin D / Pin B	37.5 k Ω
Temp. Sensor / GND	Black / Brown	Pin E / Pin B	10 k Ω
Phase / GND	-	Pin 1,2,3,4 / Pin B	>20 M Ω
All Pin / Shield	-	Pin 1-E / Housing	>20 M Ω

PS01-23x160H-HP-SSCP-G02-R20 (0150-4474)

Phase1+ / Phase1-	Red / Orange	Pin 1 / Pin 2	3.9 Ω
Phase2+ / Phase2-	Blue / Gray	Pin 3 / Pin 4	3.9 Ω
5V / GND	White / Brown	Pin A / Pin B	505 Ω
Sensor Sine / GND	Yellow / Brown	Pin C / Pin B	37.5 k Ω
Sensor Cosine / GND	Green / Brown	Pin D / Pin B	37.5 k Ω
Temp. Sensor / GND	Black / Brown	Pin E / Pin B	10 k Ω
Phase / GND	-	Pin 1,2,3,4 / Pin B	>20 M Ω
All Pin / Shield	-	Pin 1-E / Housing	>20 M Ω

6.2 Maintenance of Linear Motors

The person responsible for the operation of the motors must ensure that the specified maintenance work is carried out. The following maintenance schedule is designed for the operating conditions in the food industry with contact of liquid media. The inspection cycle is 2.5 million movement cycles or 1500 friction-kilometer.

6.2.1 Maintenance Schedule

When	What	Task
Every 2.5 million movement cycles or 1500 friction-kilometer	Slider	Check that the slider surface is clean and not scratched. Scratched sliders must be replaced, otherwise Clean the slider. See the following section.
	Electrical connection	Tighten the electrical connection between cable and stator. Tightening torque: 0.6 Nm (R-Connector)
	Ease of movement	If friction is felt during movement, the motor must be stopped immediately. Check the alignment of the load bearing and slider.

6.2.2 Cleaning

- Pull the sliders carefully out of the stator.
Attention!: Strong magnetic attraction forces (note safety instruction "contusions" on page 5.)! Use non-magnetic material (e.g. wood) to cover close-by iron constructions.
- Clean the slider and bearings with a soft disposable paper, using for example acetone or benzene cleaner. Common cleaning agents used in the food industry may also be used. However, these should not leave any residues.
- Afterwards, lubricate the bore of the stators with about 2-3 g (0.1 oz) grease LU02. There should only be a slight film of lubricant. **Note:** Do not over lubricate!
- Finally, grease the slider according to paragraph 3.2 "Assembly of the linear motor".

6.2.3 Cleaning Agent / Lubricant

All stainless steel motors from LinMot have an IP69 protection class. They can be cleaned with the usual cleaning agents, in the usual concentration and quantity as used in the food and pharmaceutical industry. If necessary, the compatibility with the bearing material (PEEK / PPS) and the cable sheath material (PUR) must be checked.

Ordering information

Item	Description	Item-No.
LU02-08	Lubricant for linear motors * (8 g)	0150-1953
LU02-50	Lubricant for linear motors * (50 g)	0150-1954
LU02-1000	Lubricant for linear motors * (1000 g)	0150-1955

* LinMot LU02 Lubricant corresponds to KLÜBERSYNTH UH1 14-31 which was developed for the food processing industry.

7 «Wash-Down» Advice

- Cleaning should only be carried out by qualified personnel.
- Cleaning should only be carried out when the machine is not in motion.
- Observe the limits of the IP69K standard for pressure, temperature, angle and distance of the cleaning agent jet.
- Observe the specifications for chemical compatibility for the materials used in the motor. See chapter 3.7.
- If the plug connection is also in the cleaning area, please refer to the details in the chapters "Motor Cable" and "Connectors".
- Do not use wire brushes or scrapers to clean the motor surface and cables. Remove dirt only by hosing down (comply with IP69K limits!) or wiping off.

8 Storage, Transport, Installation Altitude

- Sliders are to be stored and transported only in the plastic containers (with cardboard inlay) provided for this purpose, or already installed and secured in LinMot P stators.
- Remove the slider from this plastic containers only for assembling.
- The storage area must be dry, dust-free, frost-free and vibration-free.
- Prescribed storage temperature: -15 °C...70 °C
- The motor must be protected against extreme weather conditions.
- The air in the storage area must not contain any harmful gases.
- The max. installation altitude is 4'000 m above sea level.
Beyond 1'000 m, a derating of 0.5% per 100 m must be taken into account on the rated force in the case of air cooling.

9 Dimensions

9.1 Stator

9.1.1 PS01-23x80F-HP-SSCP-R20

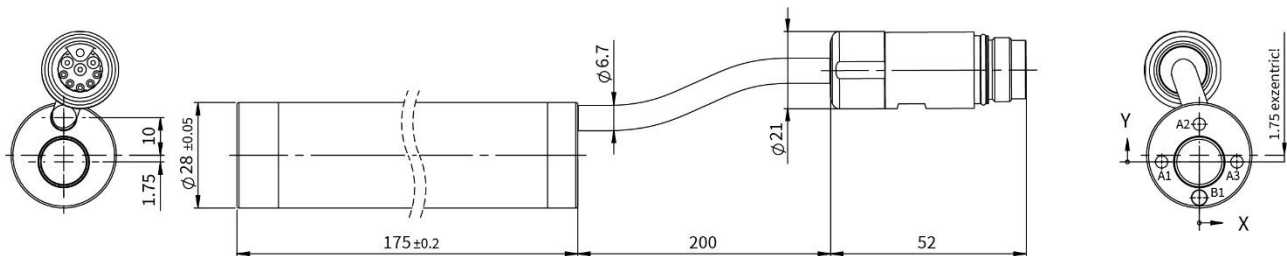

	X-POS.	Y-POS.	SIZE
A1	-10	0	M4 ∇ 7
A2	0	10	
A3	10	0	
B1	0	-9.5	\varnothing 4 H8 $\begin{matrix} +0.018 \\ 0 \end{matrix}$ ∇ 5

in mm

9.1.2 PS01-23x80F-HP-SSCP-G02-R20

	X-POS.	Y-POS.	SIZE
A1	15	-11.5	M4 ∇ 7
A2	15	11.5	
A3	50	-11.5	
A4	50	11.5	
A5	85	-11.5	
A6	85	11.5	
B1	15	0	\varnothing 4 H7 $\frac{+0.012}{0}$ ∇ 4
B2	85	0	

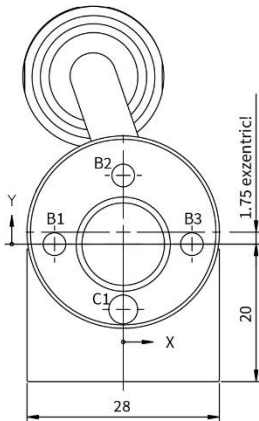
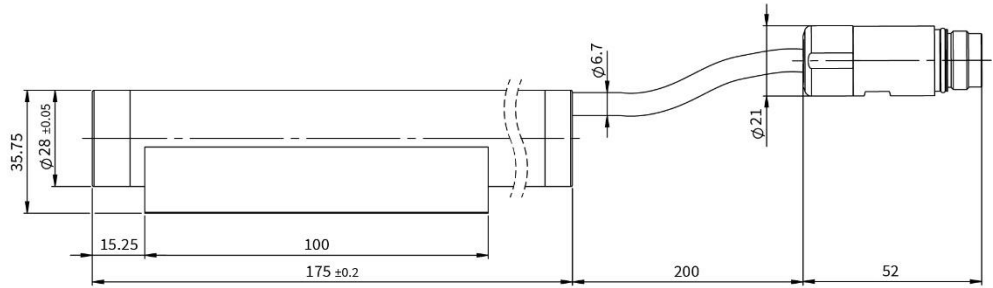
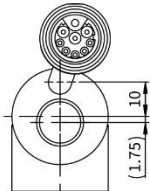
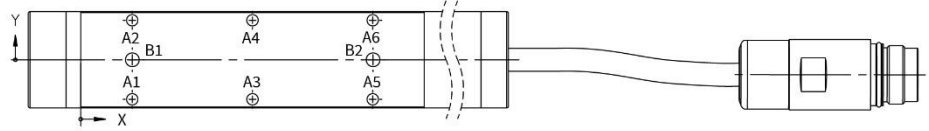

	X-POS.	Y-POS.	SIZE
B1	-10	0	M4 ∇ 7
B2	0	10	
B3	10	0	
C1	0	-9.5	\varnothing 4 H8 $\frac{+0.018}{0}$ ∇ 5

in mm

9.1.3 PS01-23x80F-HP-SSCP-R150

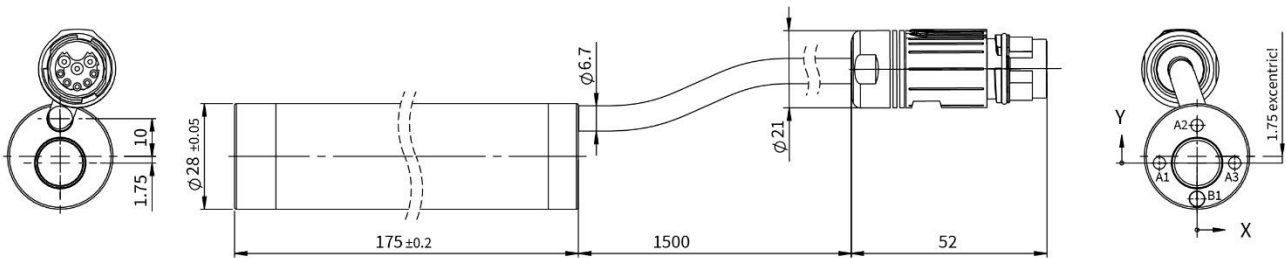

	X-POS.	Y-POS.	SIZE
A1	-10	0	M4 ∇ 7
A2	0	10	
A3	10	0	
B1	0	-9.5	\varnothing 4 H8 $\frac{+0.018}{0}$ ∇ 5

in mm

9.1.4 PS01-23x80F-HP-SSCP-G02-R150

	X-POS.	Y-POS.	SIZE
A1	15	-11.5	M4 ∇ 7
A2	15	11.5	
A3	50	-11.5	
A4	50	11.5	
A5	85	-11.5	
A6	85	11.5	
B1	15	0	ϕ 4 H7 $\begin{matrix} +0.012 \\ 0 \\ \nabla 4 \end{matrix}$
B2	85	0	

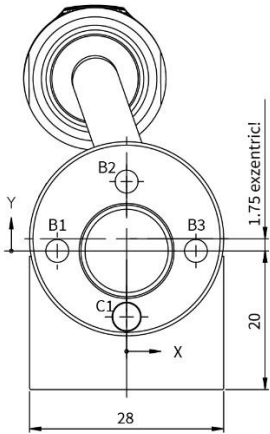
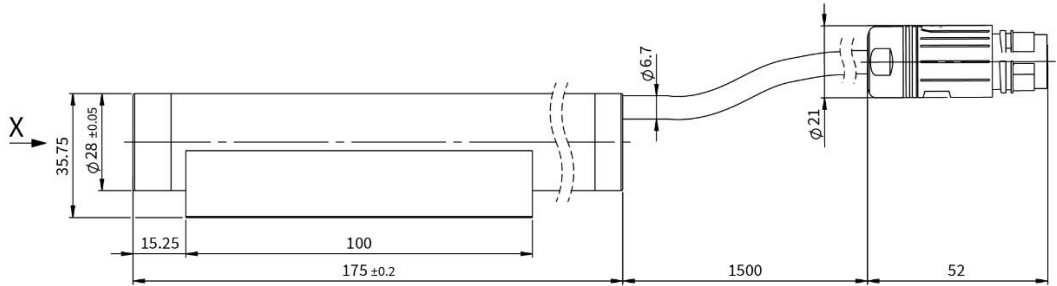
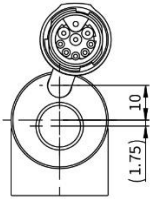
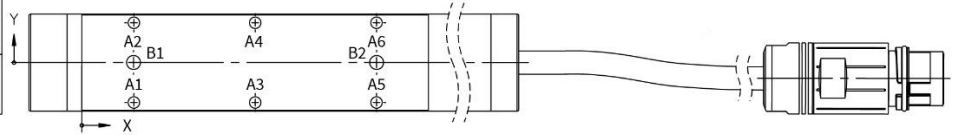

	X-POS.	Y-POS.	SIZE
B1	-10	0	M4 ∇ 7
B2	0	10	
B3	10	0	
C1	0	-9.5	ϕ 4 H8 $\begin{matrix} +0.018 \\ 0 \\ \nabla 5 \end{matrix}$

in mm

9.1.5 PS01-23x160H-HP-SSCP-R20

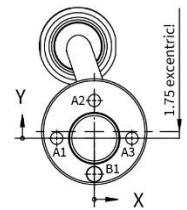
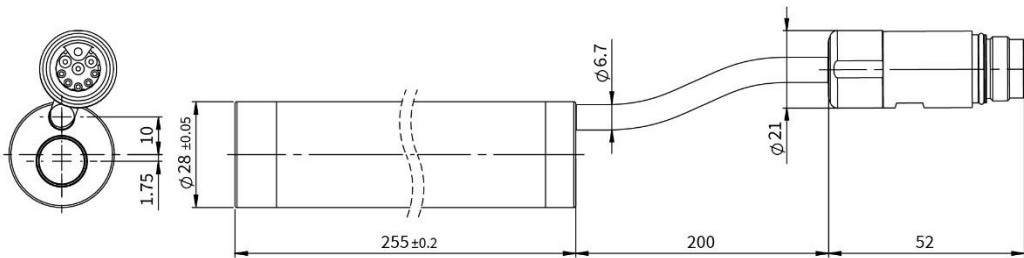

	X-POS.	Y-POS.	SIZE
A1	-10	0	M4 ∇ 7
A2	0	10	
A3	10	0	
B1	0	-9.5	ϕ 4 H8 $\begin{matrix} +0.018 \\ 0 \\ \nabla 5 \end{matrix}$

in mm

9.1.6 PS01-23x160H-HP-SSCP-G02-R20

	X-POS.	Y-POS.	SIZE
A1	15	-11.5	M4 ∇ 7
A2	15	11.5	
A3	70	-11.5	
A4	70	11.5	
A5	125	-11.5	
A6	125	11.5	
B1	105	0	ϕ 4 H7 $\begin{matrix} +0.012 \\ 0 \\ \nabla 4 \end{matrix}$
B2	35	0	

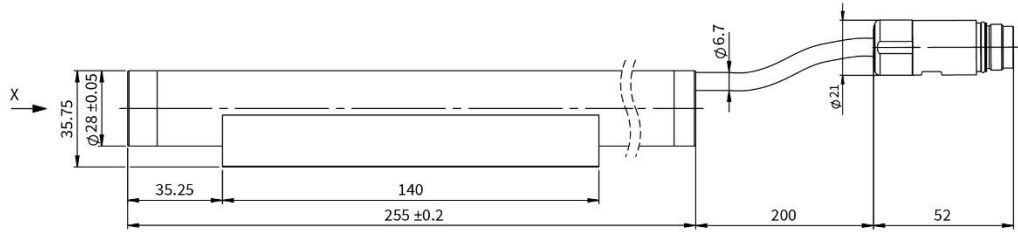
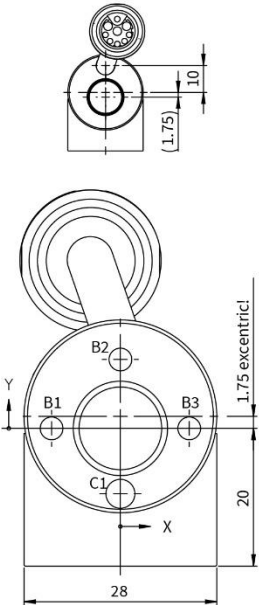
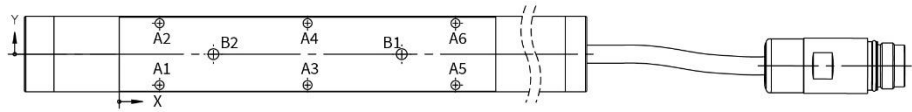

	X-POS.	Y-POS.	SIZE
B1	-10	0	M4 ∇ 7
B2	0	10	
B3	10	0	
C1	0	-9.5	ϕ 4 H8 $\begin{matrix} +0.018 \\ 0 \\ \nabla 5 \end{matrix}$

in mm

9.1.7 PS01-23x160H-HP-SSCP-R150

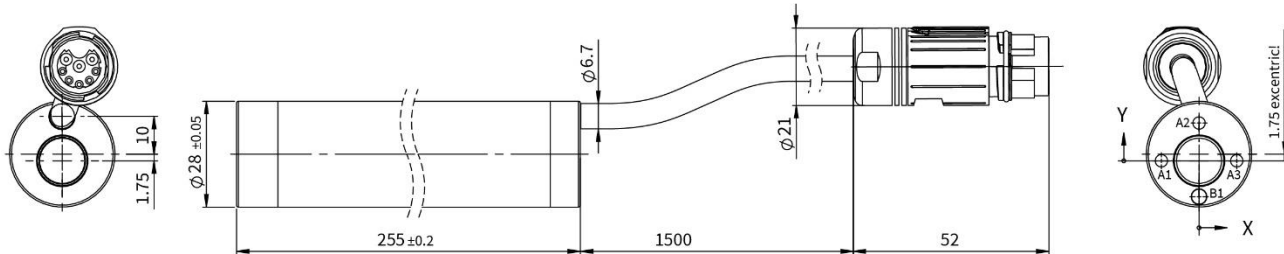

	X-POS.	Y-POS.	SIZE
A1	-10	0	M4 ∇ 7
A2	0	10	
A3	10	0	
B1	0	-9.5	ϕ 4 H8 $\begin{matrix} +0.018 \\ 0 \\ \nabla 5 \end{matrix}$

in mm

9.1.8 PS01-23x160H-HP-SSCP-G02-R150

	X-POS.	Y-POS.	SIZE
A1	125	11.5	M4 ∇ 7
A2	125	-11.5	
A3	70	11.5	
A4	70	-11.5	
A5	15	11.5	
A6	15	-11.5	
B1	35	0	\varnothing 4 H7 $\begin{smallmatrix} +0.012 \\ 0 \end{smallmatrix}$ ∇ 4
B2	105	0	

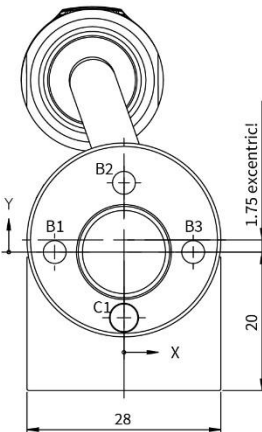
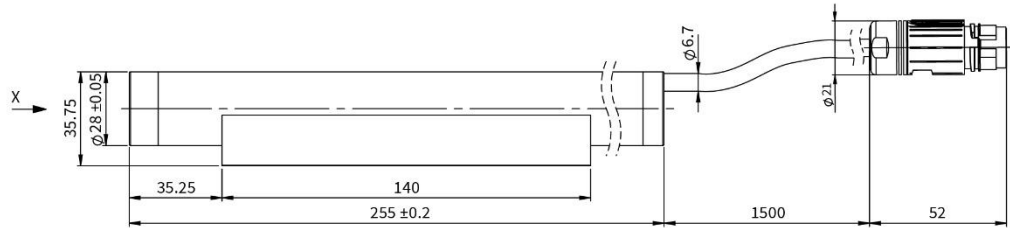
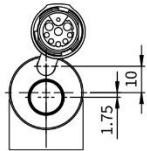
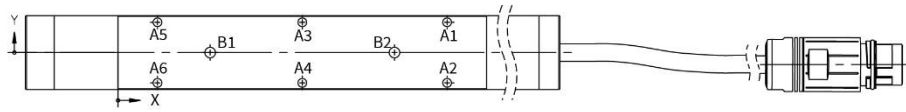

	X-POS.	Y-POS.	SIZE
B1	-10	0	M4 ∇ 7
B2	0	10	
B3	10	0	
C1	0	-9.5	\varnothing 4 H8 $\begin{smallmatrix} +0.018 \\ 0 \end{smallmatrix}$ ∇ 5

in mm

9.2 Sliders

For normal applications in both dry and wet environments the standard sliders of the PL01 series are sufficient. Their slider tube is made of an austenitic, acid-resistant 18/10 chrome-nickel steel, material no. 1.4301 (AISI 304). The heavy duty sliders PL02 are additionally coated with tungsten carbide (WC/C), have better emergency running properties and are superior to standard sliders in terms of service life in abrasive environments. Sliders of the HCR series ("high corrosion resistant") are made of stainless steel 1.4404 - chrome-nickel-molybdenum (AISI 316L). Their use is particularly recommended in environments with a high chloride content at temperatures above 60°C.

9.2.1 Sliders HP / Heavy Duty HP / HCR

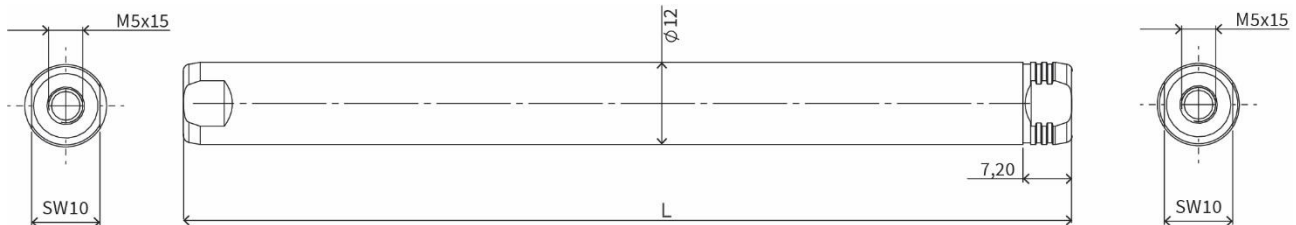

Item	Description	Item-No.	Length L [mm]
PL01-12x130/90-HP	Slider 'High Performance'	0150-2209	130
PL01-12x150/110-HP	Slider 'High Performance'	0150-2281	150
PL01-12x170/130-HP	Slider 'High Performance'	0150-1529	170
PL01-12x200/160-HP	Slider 'High Performance'	0150-1518	200
PL01-12x230/190-HP	Slider 'High Performance'	0150-1519	230
PL01-12x270/230-HP	Slider 'High Performance'	0150-1520	270
PL01-12x290/250-HP	Slider 'High Performance'	0150-1521	290
PL01-12x350/310-HP	Slider 'High Performance'	0150-1522	350
PL01-12x420/380-HP	Slider 'High Performance'	0150-1523	420
PL01-12x480/440-HP	Slider 'High Performance'	0150-1524	480
PL01-12x580/540-HP	Slider 'High Performance'	0150-1525	580
PL01-12x690/650-HP	Slider 'High Performance'	0150-2646	690
PL01-12x760/720-HP	Slider 'High Performance'	0150-1526	760
PL01-12x850/810-HP	Slider 'High Performance'	0150-1527	850

Item	Description	Item-No.	Length L [mm]
PL02-12x130/90-HP	Slider 'heavy duty' 'High Performance'	0150-2983	130
PL02-12x150/110-HP	Slider 'heavy duty' 'High Performance'	0150-3793	150
PL02-12x170/130-HP	Slider 'heavy duty' 'High Performance'	0150-1559	170
PL02-12x200/160-HP	Slider 'heavy duty' 'High Performance'	0150-1537	200
PL02-12x230/190-HP	Slider 'heavy duty' 'High Performance'	0150-1552	230
PL02-12x270/230-HP	Slider 'heavy duty' 'High Performance'	0150-1553	270
PL02-12x290/250-HP	Slider 'heavy duty' 'High Performance'	0150-1495	290
PL02-12x350/310-HP	Slider 'heavy duty' 'High Performance'	0150-1555	350
PL02-12x420/380-HP	Slider 'heavy duty' 'High Performance'	0150-1554	420
PL02-12x480/440-HP	Slider 'heavy duty' 'High Performance'	0150-2519	480
PL02-12x580/540-HP	Slider 'heavy duty' 'High Performance'	0150-2520	580
PL02-12x690/650-HP	Slider 'heavy duty' 'High Performance'	0150-4559	690
PL02-12x760/720-HP	Slider 'heavy duty' 'High Performance'	0150-2521	760
PL02-12x850/810-HP	Slider 'heavy duty' 'High Performance'	0150-2516	850

Item	Description	Item-No.	Length L [mm]
PL01-12x130/90-HP-W01	Slider 'High Performance' HCR	0150-4255	130
PL01-12x150/110-HP-W01	Slider 'High Performance' HCR	0150-4256	150
PL01-12x170/130-HP-W01	Slider 'High Performance' HCR	0150-4257	170
PL01-12x200/160-HP-W01	Slider 'High Performance' HCR	0150-4265	200
PL01-12x230/190-HP-W01	Slider 'High Performance' HCR	0150-4266	230
PL01-12x270/230-HP-W01	Slider 'High Performance' HCR	0150-4267	270
PL01-12x290/250-HP-W01	Slider 'High Performance' HCR	0150-4228	290
PL01-12x350/310-HP-W01	Slider 'High Performance' HCR	0150-4268	350
PL01-12x420/380-HP-W01	Slider 'High Performance' HCR	0150-4269	420
PL01-12x480/440-HP-W01	Slider 'High Performance' HCR	0150-4270	480
PL01-12x580/540-HP-W01	Slider 'High Performance' HCR	0150-4271	580
PL01-12x690/650-HP-W01	Slider 'High Performance' HCR	0150-4522	690
PL01-12x760/720-HP-W01	Slider 'High Performance' HCR	0150-4272	760
PL01-12x850/810-HP-W01	Slider 'High Performance' HCR	0150-4273	850

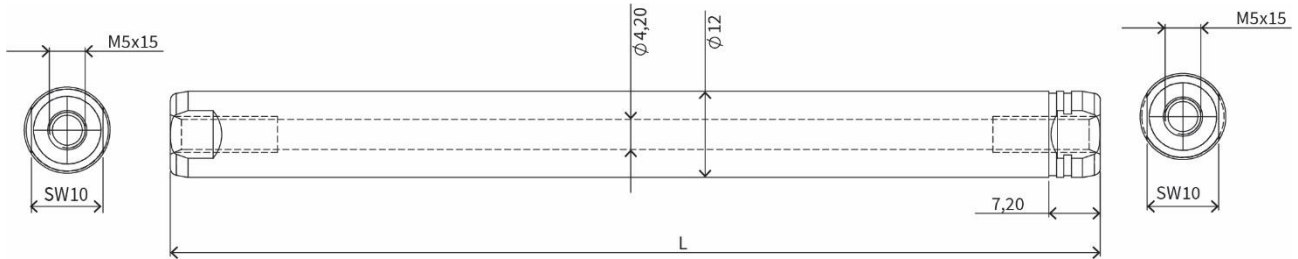

9.2.2 Hollow Sliders HP



Note: Inner wall of slider is not made of chrome steel.

Item	Description	Item-No.	Length L [mm]
PL01-12x130/90-HP-L	Slider 'High Performance L'	0150-3687	130
PL01-12x150/110-HP-L	Slider 'High Performance L'	On request	150
PL01-12x170/130-HP-L	Slider 'High Performance L'	0150-3688	170
PL01-12x200/160-HP-L	Slider 'High Performance L'	0150-3689	200
PL01-12x230/190-HP-L	Slider 'High Performance L'	0150-2546	230
PL01-12x270/230-HP-L	Slider 'High Performance L'	0150-2557	270
PL01-12x290/250-HP-L	Slider 'High Performance L'	0150-3690	290
PL01-12x350/310-HP-L	Slider 'High Performance L'	0150-3691	350
PL01-12x420/380-HP-L	Slider 'High Performance L'	0150-3692	420
PL01-12x480/440-HP-L	Slider 'High Performance L'	0150-3693	480
PL01-12x580/540-HP-L	Slider 'High Performance L'	0150-3694	580
PL01-12x690/650-HP-L	Slider 'High Performance L'	0150-4521	690
PL01-12x760/720-HP-L	Slider 'High Performance L'	0150-3695	760
PL01-12x850/810-HP-L	Slider 'High Performance L'	On request	850

10 International Certificates

<p>Europe</p> 	<p>See chapter "EU Declaration of Conformity CE-Marking"</p>
<p>UK</p> 	<p>See chapter "UK Declaration of Conformity UKCA-Marking"</p>
<p>IECEE CB SCHEME</p>	<p>Ref. Certif. Nr. CH-8521</p>
<p>USA / Canada</p> 	<p>File Number E354430 Refers to cURus marked motors</p>

 	Ref. Certif. No. CH-8521
---	---------------------------------



IEC SYSTEM FOR MUTUAL RECOGNITION OF TEST CERTIFICATES FOR ELECTRICAL EQUIPMENT (IECEE) CB SCHEME

CB TEST CERTIFICATE

Product	Linear motor	
Name and address of the applicant	NTI AG	Bodenackerstrasse 2 SWITZERLAND 8957 Spreitenbach
Name and address of the manufacturer	NTI AG	Bodenackerstrasse 2 SWITZERLAND 8957 Spreitenbach
Name and address of the factory	NTI AG	Bodenackerstrasse 2 SWITZERLAND 8957 Spreitenbach
<i>Note: When more than one factory, please report on page 2</i>	<input type="checkbox"/> Additional Information on page 2	
Ratings and principal characteristics	supplied via servo drive, see TR 17-EL-0006.E02 for details	
Trade mark (if any)	LinMot	
Customers's Testing Facility (CTF) Stage used	---	
Model / Type Ref.	PR series PS series P04 series P05 series	
Additional information (if necessary may also be reported on page 2)	---	
	<input type="checkbox"/> Additional Information on page 2	
A sample of product was tested and found to be in conformity with IEC	IEC 61000-6-2:2016 IEC 61000-6-4:2006, IEC 61000-6-4:2006/AMD1:2010 IEC 61000-6-7:2014	
National differences	EU Group Differences; EU Special National Conditions; EU A-Deviations	
As shown in the Test Report Ref. No. which forms part of this Certificate	17-EL-0006.E01 + .E02 + .Z01	



This CB Test Certificate is issued by the National Certification Body

Electrosuisse Luppenstrasse 1 8320 Fehraltorf SWITZERLAND		 page 1 of 1
Signed by: Martin Plüss Date: 2017-03-13		

CERTIFICATE OF COMPLIANCE

Certificate Number UL-US-2138367-0
Report Reference E354430-20210817
Date 23-Aug-2021

Issued to: NTI AG
Bodenaeckerstr 2 SPREITENBACH
Switzerland 8957

**This is to certify that
representative samples of**

NDMM2 - Incomplete Rotating Machines and Rotating
Machine Parts - Component

See Addendum Page for Product Designation(s).

Have been investigated by UL in accordance with the
component requirements in the Standard(s) indicated on
this Certificate. UL Recognized components are incomplete
in certain constructional features or restricted in
performance capabilities and are intended for installation in
complete equipment submitted for investigation to UL LLC.

Standard(s) for Safety: UL 1004-1, 2nd Ed., Issue Date: 2012-09-19, Revision
Date: 2020-11-05

Additional Information: See the UL Online Certifications Directory at
<https://iq.ulprospector.com> for additional information

This *Certificate of Compliance* does not provide authorization to apply the UL Recognized Component Mark.
Only the UL Follow-Up Services Procedure provides authorization to apply the UL Mark.

Only those products bearing the UL Recognized Component Mark should be considered as being UL Certified
and covered under UL's Follow-Up Services.

Look for the UL Recognized Component Mark on the product.

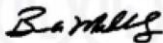

Bruce Mahrenholz, Director North American Certification Program

UL LLC

Any information and documentation involving UL Mark services are provided on behalf of UL LLC (UL) or any authorized licensee of UL. For questions, please
contact a local UL Customer Service Representative at <http://ul.com/aboutul/locations/>



CERTIFICATE OF COMPLIANCE

Certificate Number UL-US-2138367-0
Report Reference E354430-20210817
Date 23-Aug-2021

This is to certify that representative samples of the product as specified on this certificate were tested according to the current UL requirements

Model	Category Description
PS01 , PS01, Followed by 2 digits, Followed by "x" or "Sx", Followed by 2 or 3 digits, Followed by "-", "F", "H" or "G", Followed by HP, followed by "B" plus 2 digits, Followed by SSCP, followed by "G" plus 2 digits (optional), followed by R, C, H, M or MF, Followed by 2 or 3 digits (optional), followed by any alphanumeric digit (optional)	Incomplete Motor Parts
SM01 , SM01, Followed by 2 digits, Followed by "x" or "Sx", Followed by 2 or 3 digits, Followed by "-", "F", "H" or "G", Followed by HP, Followed by R, C, H, M or MF, Followed by 2 or 3 digits (Optional), Followed by 2 or 3 digits, Followed by "BE" plus 2 digits (Optional), Followed by "MS" plus 2 digits (Optional), Followed by "EN" plus 2 digits (Optional), Followed by "FS" plus 2 digits (Optional), Followed by "BK" plus 2 digits (Optional), Followed by SSCP, followed by "-" or any alphanumeric digit.	Incomplete Motor Parts
SM02 , SM02, Followed by 2 digits, Followed by "x" or "Sx", Followed by 2 or 3 digits, Followed by "-", "F", "H" or "G", Followed by HP, Followed by R, C, H, M or MF, Followed by 2 or 3 digits (Optional), Followed by 2 or 3 digits, Followed by "BE" plus 2 digits (Optional), Followed by "MS" plus 2 digits (Optional), Followed by "EN" plus 2 digits (Optional), Followed by "FS" plus 2 digits (Optional), Followed by "BK" plus 2 digits (Optional), Followed by SSCP, followed by "-" or any alphanumeric digit.	Incomplete Motor Parts

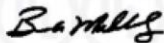

Bruce Mahrenholz, Director North American Certification Program

UL LLC

Any information and documentation involving UL Mark services are provided on behalf of UL LLC (UL) or any authorized licensee of UL. For questions, please contact a local UL Customer Service Representative at <http://ul.com/aboutul/locations/>



CERTIFICATE OF COMPLIANCE

Certificate Number UL-CA-2128754-0
Report Reference E354430-20210817
Date 23-Aug-2021

Issued to: NTI AG
Bodenaeckerstr 2 SPREITENBACH
Switzerland 8957

This is to certify that representative samples of NDMM8 - Incomplete Rotating Machines and Rotating Machine Parts Certified for Canada - Component
See Addendum Page for Product Designation(s).

Have been investigated by UL in accordance with the component requirements in the Standard(s) indicated on this Certificate. UL Recognized components are incomplete in certain constructional features or restricted in performance capabilities and are intended for installation in complete equipment submitted for investigation to UL LLC.

Standard(s) for Safety: CSA C22.2 NO. 100, 7th Ed., Issue Date: 2014-07-01, Revision Date: 2017-04-01

Additional Information: See the UL Online Certifications Directory at <https://iq.ulprospector.com> for additional information

This *Certificate of Compliance* does not provide authorization to apply the UL Recognized Component Mark. Only the UL Follow-Up Services Procedure provides authorization to apply the UL Mark.

Only those products bearing the UL Recognized Component Mark should be considered as being UL Certified and covered under UL's Follow-Up Services.

Look for the UL Recognized Component Mark on the product.

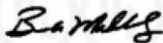

Bruce Mahrenholz, Director North American Certification Program

UL LLC

Any information and documentation involving UL Mark services are provided on behalf of UL LLC (UL) or any authorized licensee of UL. For questions, please contact a local UL Customer Service Representative at <http://ul.com/aboutul/locations/>



CERTIFICATE OF COMPLIANCE

Certificate Number UL-CA-2128754-0
Report Reference E354430-20210817
Date 23-Aug-2021

This is to certify that representative samples of the product as specified on this certificate were tested according to the current UL requirements

Model	Category Description
PS01 , PS01, Followed by 2 digits, Followed by "x" or "Sx", Followed by 2 or 3 digits, Followed by "-", "F", "H" or "G", Followed by HP, followed by "B" plus 2 digits, Followed by SSCP, followed by "G" plus 2 digits (optional), followed by R, C, H, M or MF, Followed by 2 or 3 digits (optional), followed by any alphanumeric digit (optional)	Incomplete Motor Parts
SM01 , SM01, Followed by 2 digits, Followed by "x" or "Sx", Followed by 2 or 3 digits, Followed by "-", "F", "H" or "G", Followed by HP, Followed by R, C, H, M or MF, Followed by 2 or 3 digits (Optional), Followed by 2 or 3 digits, Followed by "BE" plus 2 digits (Optional), Followed by "MS" plus 2 digits (Optional), Followed by "EN" plus 2 digits (Optional), Followed by "FS" plus 2 digits (Optional), Followed by "BK" plus 2 digits (Optional), Followed by SSCP, followed by "-" or any alphanumeric digit.	Incomplete Motor Parts
SM02 , SM02, Followed by 2 digits, Followed by "x" or "Sx", Followed by 2 or 3 digits, Followed by "-", "F", "H" or "G", Followed by HP, Followed by R, C, H, M or MF, Followed by 2 or 3 digits (Optional), Followed by 2 or 3 digits, Followed by "BE" plus 2 digits (Optional), Followed by "MS" plus 2 digits (Optional), Followed by "EN" plus 2 digits (Optional), Followed by "FS" plus 2 digits (Optional), Followed by "BK" plus 2 digits (Optional), Followed by SSCP, followed by "-" or any alphanumeric digit.	Incomplete Motor Parts

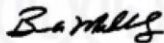

Bruce Mahrenholz, Director North American Certification Program

UL LLC

Any information and documentation involving UL Mark services are provided on behalf of UL LLC (UL) or any authorized licensee of UL. For questions, please contact a local UL Customer Service Representative at <http://ul.com/aboutul/locations/>



11 EU Declaration of Conformity CE-Marking

NTI AG / LinMot®
Bodenaeckerstrasse 2
8957 Spreitenbach

Switzerland

Tel.: +41 (0)56 419 91 91

Fax: +41 (0)56 419 91 92

declares under sole responsibility the compliance of the products:

- Linear Motors of the Series **PS01-23 SSCP**

with the EMC Directive 2014/30/EU.

Applied harmonized standards:

- **EN 61000-6-2: 2005 (Immunity for industrial environments)**
- **EN 61000-6-4: 2007 + A1: 2011 (Emission for industrial environments)**

According to the EMC directive, the listed devices are not independently operable products.

Compliance of the directive requires the correct installation of the product, the observance of specific installation guides and product documentation. This was tested on specific system configurations.

The safety instructions of the manuals are to be considered.

The product must be mounted and used in strict accordance with the installation instructions contained within the installation guide, a copy of which may be obtained from NTI AG.

Company: NTI AG
Spreitenbach, 02.08.2024



Dr.-Ing. Ronald Rohner
CEO NTI AG

12 UK Declaration of Conformity UKCA-Marking

NTI AG / LinMot®
Bodenaeckerstrasse 2
8957 Spreitenbach

Switzerland

Tel.: +41 (0)56 419 91 91

Fax: +41 (0)56 419 91 92

declares under sole responsibility the compliance of the products:

- Linear Motors of the Series **PS01-23 SSCP**

with the EMC Regulation S.I. 2016 No. 1091.

Applied designated standards:

- **EN 61000-6-2: 2005 (Immunity for industrial environments)**
- **EN 61000-6-4: 2007 + A1: 2011 (Emission for industrial environments)**

According to the EMC regulation, the listed devices are not independently operable products.

Compliance of the regulation requires the correct installation of the product, the observance of specific installation guides and product documentation. This was tested on specific system configurations.

The safety instructions of the manuals are to be considered.

The product must be mounted and used in strict accordance with the installation instructions contained within the installation guide, a copy of which may be obtained from NTI AG.

Company: NTI AG
Spreitenbach, 02.08.2024



Dr.-Ing. Ronald Rohner
CEO NTI AG

ALL LINEAR MOTION FROM A SINGLE SOURCE

Europe / Asia Headquarters

NTI AG - LinMot & MagSpring

Bodenaeckerstrasse 2
CH-8957 Spreitenbach
Switzerland

Sales / Administration: +41 56 419 91 91
office@linmot.com

Tech. Support: +41 56 544 71 00
support@linmot.com

Web: <https://www.linmot.com/>

Visit <https://linmot.com/contact/> to find a distributor near you.

North / South America Headquarters

LinMot USA Inc.

N1922 State Road 120, Unit 1
Lake Geneva, WI 53147
USA

Sales / Administration: 262.743.2555
usasales@linmot.com

Tech. Support: 262.743.2555
usasupport@linmot.com

Web: <https://www.linmot.com/>