

LINEAR MOTORS P01-23X160H-HP-SSCP



- ✓ Stainless steel housing EN 1.4404 / AISI / SAE 316L
- ✓ Compact, slim and hygienic design
- ✓ Protection against external influences (protection class IP66/IP67, IP69S)
- ✓ For environments with high humidity
- ✓ Ideal for food applications
- ✓ Resistant to dry cleaning and disinfectants
- ✓ Efficient cleaning of contaminations (germs, microorganisms etc.)
- ✓ Maximum protection against flash rust and oxidation
- ✓ Reduced cabling due to single-cable solution with LinMot encoder technology

LINEAR MOTORS P01-23X160H-HP-SSCP

Description _____	3
Technical Data _____	4
Motor Specifications	
P01-23x160H/20x160-HP-SSCP	9
P01-23x160H/60x200-HP-SSCP	10
P01-23x160H/80x220-HP-SSCP	11
P01-23x160H/140x280-HP-SSCP	12
P01-23x160H/210x350-HP-SSCP	13
P01-23x160H/270x410-HP-SSCP	14
P01-23x160H/370x510-HP-SSCP	15
P01-23x160H/480x620-HP-SSCP	16
P01-23x160H/550x690-HP-SSCP	17
P01-23x160H/640x780-HP-SSCP	18
Accessories _____	19

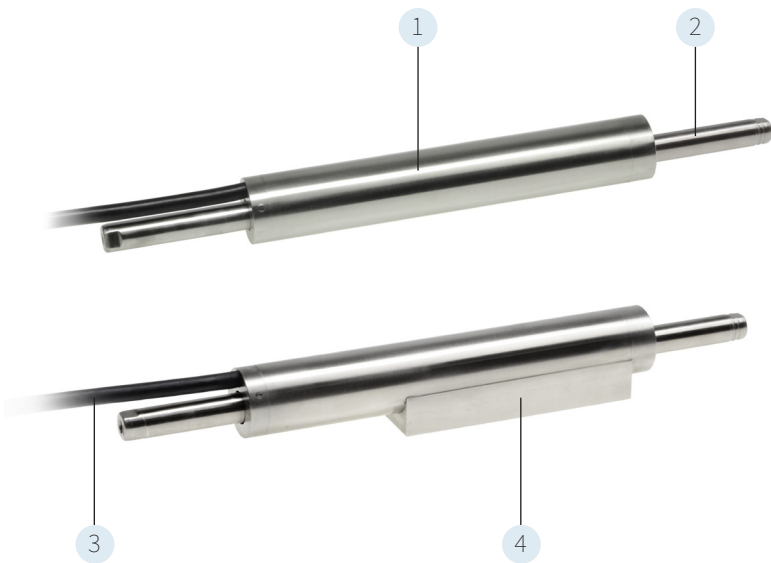

1. Stainless steel linear motor with integrated temperature and position sensors
2. Magnetic slider of the linear motor (magnets are protected in a stainless steel tube.)
3. Cable connector with cable length 1.5 m (protection class IP67) or cable plug with cable length 0.2 m (protection class IP69)
4. Mounting flange for flexible fastening and efficient heat dissipation

The linear motors P01-23x160H-HP-SSCP are the slimmest representatives in the SSC product family. They are made completely of stainless steel and achieve protection class IP 69, thus enabling them to be used optimally in machines and systems for food processing or for operation in the pharmaceutical industry. The simple design makes it particularly easy for the user to remove dirt, germs and micro-organisms from the drive unit and also offers sufficient freedom for installation in the plant. Chemical cleaning and the use of disin-

fectants can be applied to the motors without any problems. In addition to the simple, purely tubular motor variant, LinMot also offers a motor with an integrated mounting flange. Due to its larger surface area, this motor type provides more efficient heat dissipation and offers several options for mounting the motor. The already established single-cable solution with LinMot encoder technology is also available for this motor type and leads to significantly less cabling effort on the user side.

Designation Code Linear Motors P01-23x160H-HP-SSCP

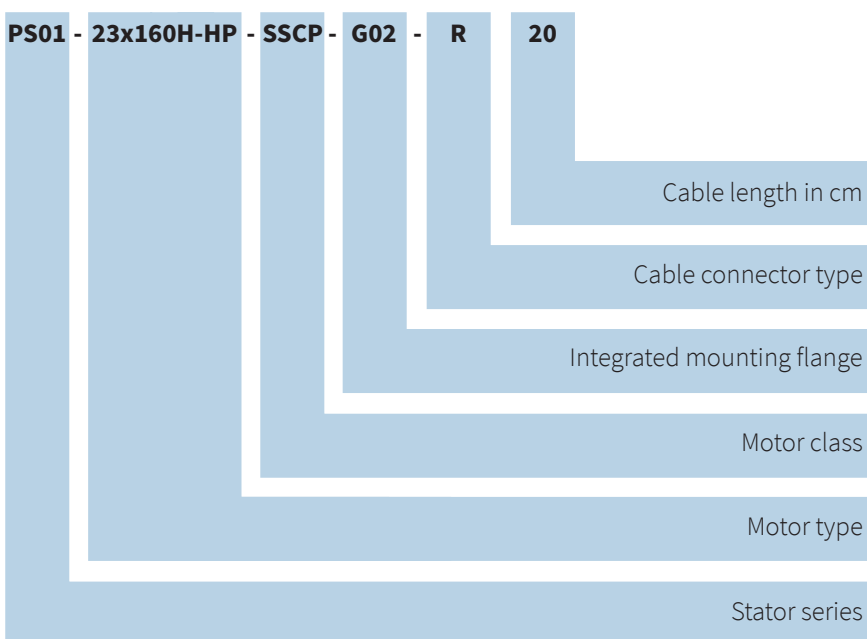

The P01-23x160H-HP-SSCP product family currently offers more than 40 stator-runner combinations. The difference between the stators are the cable connectors and the mounting flange. The number of slider lengths provides the user with a perfectly matched stroke spectrum.



MOTOR FAMILY PS01-23X160H-HP-SSCP

Technical Data				
Stroke				
Maximum Stroke	mm	(in)	780	(30.69)
Force				
Max. Force @ 48VDC	N	(lbf)	126	(28.32)
Max. Force @ 72VDC	N	(lbf)	138	(31.02)
Max. Cont. Force without Mounting Flange [Passive cooling]	N	(lbf)	21.5	(4.83)
Max. Cont. Force with Mounting Flange G02 [Passive cooling/ Passive mounted ¹ / Cold Plate ²]	N	(lbf)	23.5 / 30 / 35	(5.28 / 6.74 / 7.87)
Max. Border Force relative		%	56	
Force Constant	N/A _{pk}	(lbf/A _{pk})	12.5	(2.81)
Velocity				
Max. Velocity @ 48VDC	m/s	(in/s)	3.4	(133.9)
Max. Velocity @ 72VDC	m/s	(in/s)	5.2	(204.7)
Position Detection				
Position Resolution	mm	(in)	0.002	(0.0002)
Repeatability	mm	(in)	±0.05	(±0.002)
Electrical Data				
Max. Current @ 48VDC	A _{pk}		10	
Max. Current @ 72VDC	A _{pk}		10	
Max. Cont. Current without Mounting Flange [Passive cooling]	A _{pk}		1.7	
Max. Cont. Current with Mounting Flange G02 [Passive cooling/ Passive mounted ¹ / Cold Plate ²]	A _{pk}		1.9 / 2.4 / 2.9	
Terminal Resistance 25 °C / 150 °C	Ohm		3.9 / 5.7	
Terminal Inductivity	mH		0.54	
Magnetic Period	mm	(in)	20	(787.4)
Thermal Data				
Max. Winding Temperature (Sensor)	°C		120	
Thermal Resistance without Mounting Flange [Passive cooling]	°K/W		5	
Thermal Resistance with Mounting Flange G02 [Passive cooling/ Passive mounted ¹ / Cold Plate ²]	°K/W		4.3 / 2.7 / 2	
Thermal Time Constant without Mounting Flange [Passive cooling]	s		600	
Thermal Time Constant with Mounting Flange G02 [Passive cooling/ Passive mounted ¹ / Cold Plate ²]	s		800 / 1500 / 400	
Mechanical Data				
Stator Diameter	mm	(in)	28	(1.1)
Stator Length	mm	(in)	255	(10.04)
Stator Mass [without Mounting Flange / with Mounting Flange G02]	g	(lb)	520 / 820	(1.15 / 1.81)
Slider Diameter	mm	(in)	12	(0.47)
Slider Length	mm	(in)	200 - 850	(7.87 - 33.4)
Slider Mass	g	(lb)	155 - 700	(0.34 - 1.54)
IP Code [Connector Type R20 / Connector Type R150]			IP 69S / IP 67	
Material Housing			EN 1.4404	
Material Stator-Bearing			PEEK / PPS	
Motor Connection				
Cable Cross Section	mm	(in)	6.7	(0.26)
Cable Weight	g/m	(lb/in)	64	(0.0036)
Cable Length [Connector Type R20 / Connector Type R150]	mm	(in)	200 / 1500	(7.87 / 59.06)
Cable Sheath			PUR	
Minimum Bending Radius	mm	(in)	25	(0.98)

1) Motor is mounted on a stainless steel surface of 0.03 m².
 2) Motor is mounted on a 20°C cold plate.

STATOR

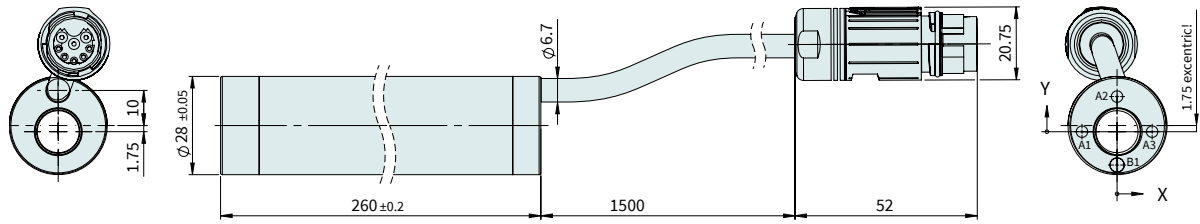

	X-POS.	Y-POS.	SIZE
A1	-10	0	M4 ∇ 7
A2	0	10	
A3	10	0	
B1	0	-9.5	\varnothing 4 H8 $\begin{matrix} +0.018 \\ 0 \\ \nabla 5 \end{matrix}$

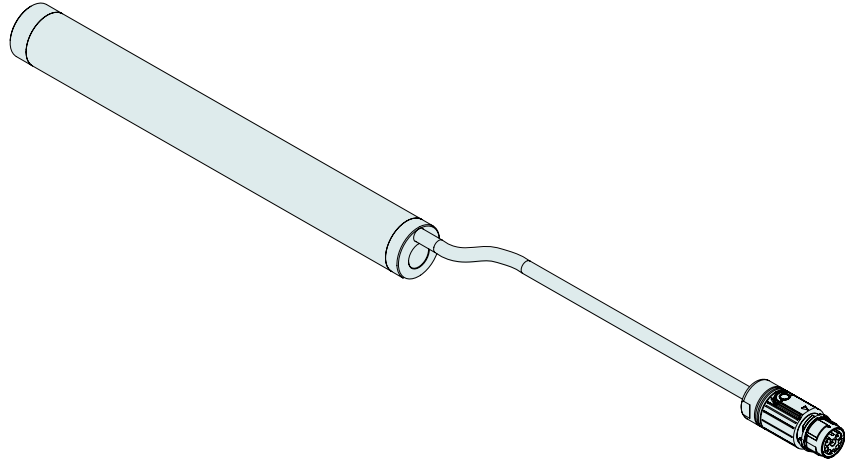

Item	Description	Item-No.
PS01-23x160H-HP-SSCP-R150	Stainless Steel Stator Performance, 1.5m Cable	0150-4380

	X-POS.	Y-POS.	SIZE
A1	125	11.5	M4 ∇ 7
A2	125	-11.5	
A3	70	11.5	
A4	70	-11.5	
A5	15	11.5	
A6	15	-11.5	
B1	35	0	\varnothing 4 H7 $\begin{matrix} -0.012 \\ 0 \\ \nabla 4 \end{matrix}$
B2	105	0	

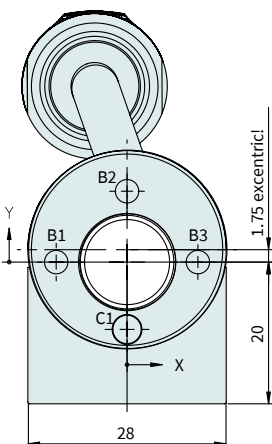
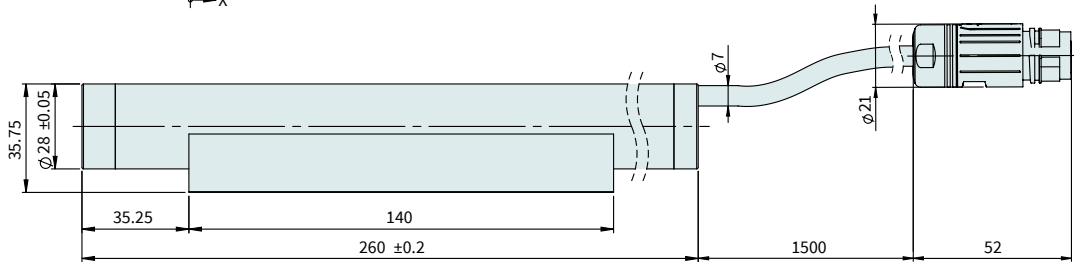
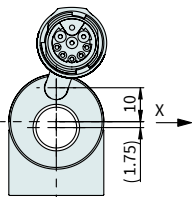
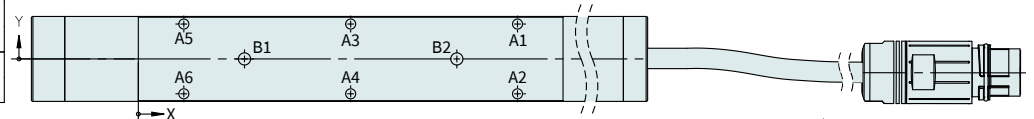

	X-POS.	Y-POS.	SIZE
B1	-10	0	M4 ∇ 7
B2	0	10	
B3	10	0	
C1	0	-9.5	\varnothing 4 H8 $\begin{matrix} +0.018 \\ 0 \\ \nabla 5 \end{matrix}$

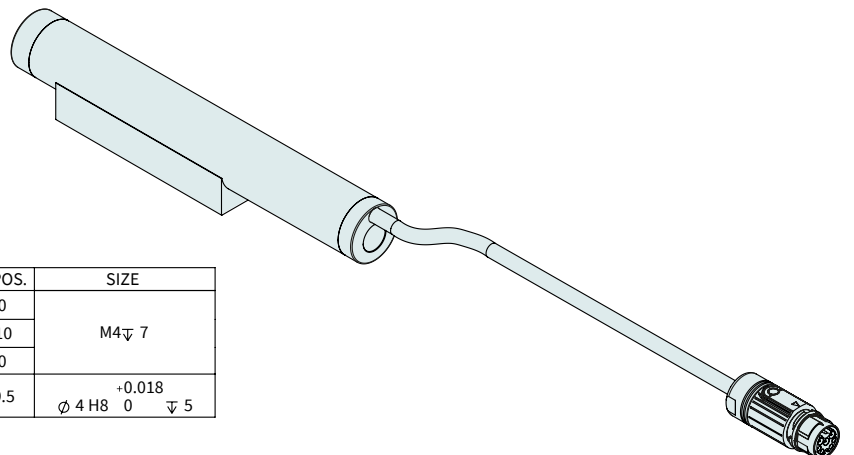

Item	Description	Item-No.
PS01-23x160H-HP-SSCP-G02-R150	Stainless Steel Stator Performance mit Flansch, 1.5m Cable	0150-4473

STATOR

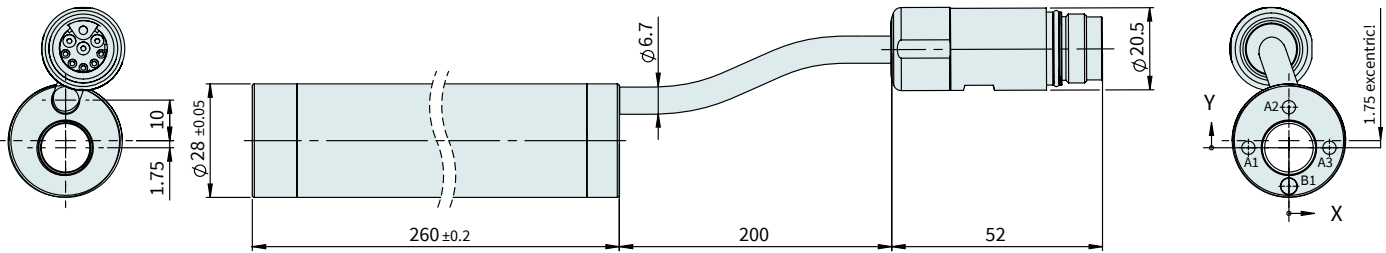

	X-POS.	Y-POS.	SIZE
A1	-10	0	M4 ∇ 7
A2	0	10	
A3	10	0	
B1	0	-9.5	∇ 5
			ϕ 4 H8 $\begin{matrix} +0.018 \\ 0 \end{matrix}$

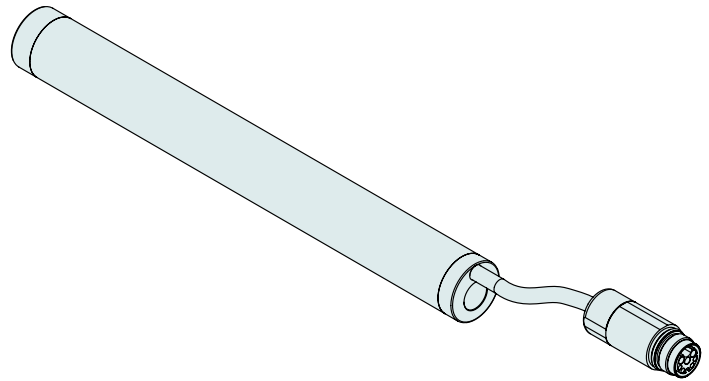

Item	Description	Item-No.
PS01-23x160H-HP-SSCP-R20	Stainless Steel Stator Performance, 0.2m Cable, SSC-Connector	0150-4381

	X-POS.	Y-POS.	SIZE
A1	15	-11.5	M4 ∇ 7
A2	15	11.5	
A3	70	-11.5	
A4	70	11.5	
A5	125	-11.5	
A6	125	11.5	
B1	105	0	∇ 4
B2	35	0	ϕ 4 H7 $\begin{matrix} +0.012 \\ 0 \end{matrix}$

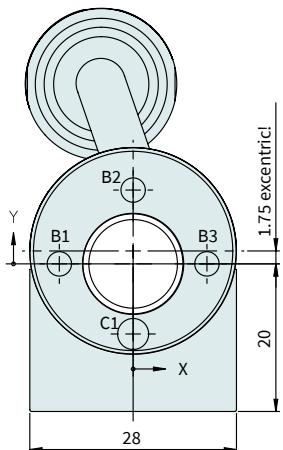
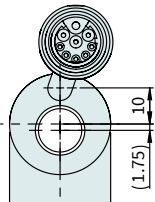
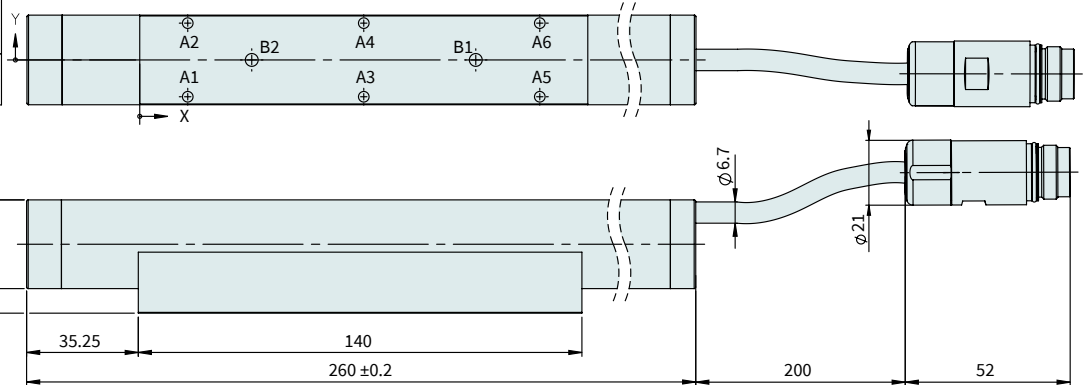

	X-POS.	Y-POS.	SIZE
B1	-10	0	M4 ∇ 7
B2	0	10	
B3	10	0	
C1	0	-9.5	∇ 5
			ϕ 4 H8 $\begin{matrix} +0.018 \\ 0 \end{matrix}$

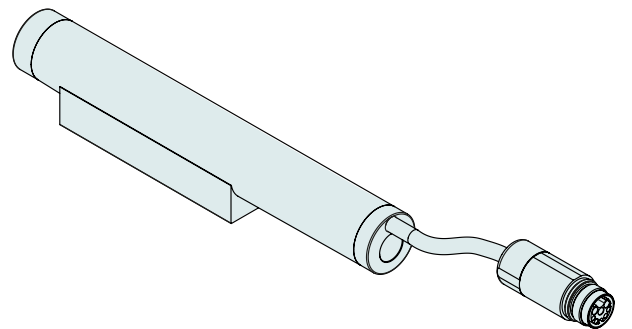

Item	Description	Item-No.
PS01-23x160H-HP-SSCP-G02-R20	Stainless Steel Stator Performance mit Flansch, 0.2m Cable, SSC-Connector	0150-4474

CONNECTOR

Motor Connector Wiring	R-Connector	Wire color motor cable
Ph 1+	1	red
Ph 1-	2	pink
Ph 2+	3	blue
Ph 2-	4	grey
+5VDC	A	white
GND	B	inner Shield
Sinus	C	yellow
Cosinus	D	green
Temp.	E	black
Shield	Case	outer Shield

R-Connector

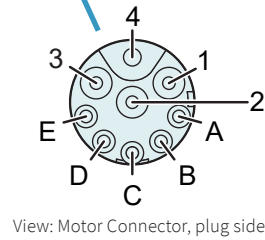

SLIDER

For normal applications in both dry and wet environments the standard sliders of the PL01 series are sufficient. Their slider tube is made of an austenitic, acid-resistant 18/10 chrome-nickel steel, material no. 1.4301 (AISI 304). The heavy duty sliders PL02 are additionally coated with tungsten carbide (WC/C), have better emergency running properties and are superior

to standard sliders in terms of service life in abrasive environments. Sliders of the HCR series ("high corrosion resistant") are made of stainless steel 1.4404 - chrome-nickel-molybdenum (AISI 316L). Their use is particularly recommended in environments with a high chloride content at temperatures above 60°C.

Slider HP / HCR

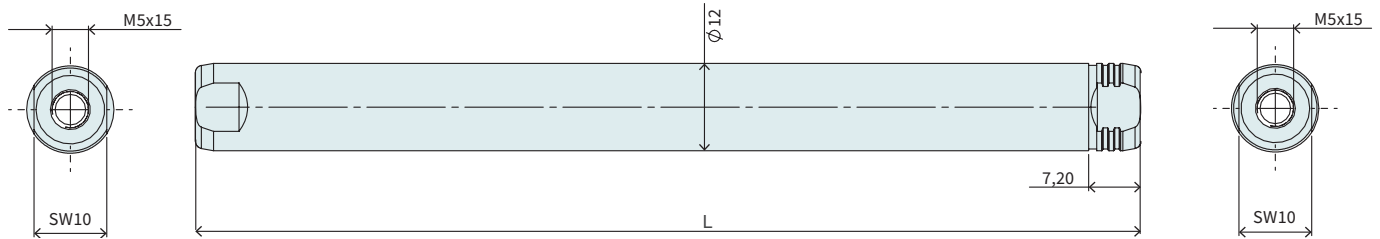

Hollow Slider HP

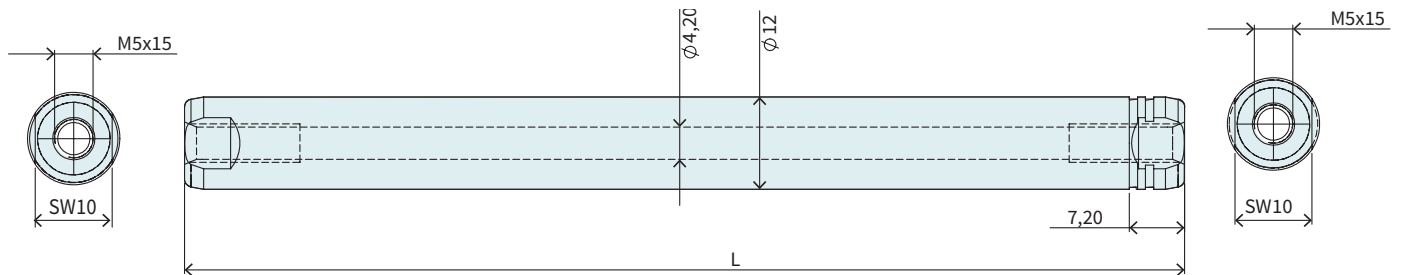

Slider High Performance				
Item	Description	Max. Stroke [mm]	Standard Stroke [mm]	Item-No.
PL01-12x230/190-HP	Slider 'High Performance'	160	20	0150-1519
PL01-12x270/230-HP	Slider 'High Performance'	200	60	0150-1520
PL01-12x290/250-HP	Slider 'High Performance'	220	80	0150-1521
PL01-12x350/310-HP	Slider 'High Performance'	280	140	0150-1522
PL01-12x420/380-HP	Slider 'High Performance'	350	210	0150-1523
PL01-12x480/440-HP	Slider 'High Performance'	410	270	0150-1524
PL01-12x580/540-HP	Slider 'High Performance'	510	370	0150-1525
PL01-12x690/650-HP	Slider 'High Performance'	620	480	0150-2646
PL01-12x760/720-HP	Slider 'High Performance'	690	550	0150-1526
PL01-12x850/810-HP	Slider 'High Performance'	780	640	0150-1527

Slider Heavy Duty / High Performance				
Item	Description	Max. Stroke [mm]	Standard Stroke [mm]	Item-No.
PL02-12x230/190-HP	Slider 'heavy duty' 'High Performance'	160	20	0150-1552
PL02-12x270/230-HP	Slider 'heavy duty' 'High Performance'	200	60	0150-1533
PL02-12x290/250-HP	Slider 'heavy duty' 'High Performance'	220	80	0150-1495
PL02-12x350/310-HP	Slider 'heavy duty' 'High Performance'	280	140	0150-1555
PL02-12x420/380-HP	Slider 'heavy duty' 'High Performance'	350	210	0150-1554
PL02-12x480/440-HP	Slider 'heavy duty' 'High Performance'	410	270	0150-2519
PL02-12x580/540-HP	Slider 'heavy duty' 'High Performance'	510	370	0150-2520
PL02-12x690/650-HP	Slider 'heavy duty' 'High Performance'	620	480	0150-4559
PL02-12x760/720-HP	Slider 'heavy duty' 'High Performance'	690	550	0150-2521
PL02-12x850/810-HP	Slider 'heavy duty' 'High Performance'	780	640	0150-2516

Slider High Performance HCR				
Item	Description	Max. Stroke [mm]	Standard Stroke [mm]	Item-No.
PL01-12x230/190-HP-W01	Slider 'High Performance' HCR	160	20	0150-4266
PL01-12x270/230-HP-W01	Slider 'High Performance' HCR	200	60	0150-4267
PL01-12x290/250-HP-W01	Slider 'High Performance' HCR	220	80	0150-4228
PL01-12x350/310-HP-W01	Slider 'High Performance' HCR	280	140	0150-4268
PL01-12x420/380-HP-W01	Slider 'High Performance' HCR	350	210	0150-4269
PL01-12x480/440-HP-W01	Slider 'High Performance' HCR	410	270	0150-4270
PL01-12x580/540-HP-W01	Slider 'High Performance' HCR	510	370	0150-4271
PL01-12x690/650-HP-W01	Slider 'High Performance' HCR	620	480	0150-4522
PL01-12x760/720-HP-W01	Slider 'High Performance' HCR	690	550	0150-4272
PL01-12x850/810-HP-W01	Slider 'High Performance' HCR	780	640	0150-4273

Hollow Slider High Performance				
Item	Description	Max. Stroke [mm]	Standard Stroke [mm]	Item-No.
PL01-12x230/190-HP-L	Slider 'High Performance L'	160	20	0150-2546
PL01-12x270/230-HP-L	Slider 'High Performance L'	200	60	0150-2557
PL01-12x290/250-HP-L	Slider 'High Performance L'	220	80	0150-3690
PL01-12x350/310-HP-L	Slider 'High Performance L'	280	140	0150-3691
PL01-12x420/380-HP-L	Slider 'High Performance L'	350	210	0150-3692
PL01-12x480/440-HP-L	Slider 'High Performance L'	410	270	0150-3693
PL01-12x580/540-HP-L	Slider 'High Performance L'	510	370	0150-3694
PL01-12x690/650-HP-L	Slider 'High Performance L'	620	480	0150-4521
PL01-12x760/720-HP-L	Slider 'High Performance L'	690	550	0150-3695
PL01-12x850/810-HP-L	Slider 'High Performance L'	780	640	Auf Anfrage

P01-23x160H/20x160-HP-SSCP

Max. Stroke: 160 mm
Peak Force: 138 N

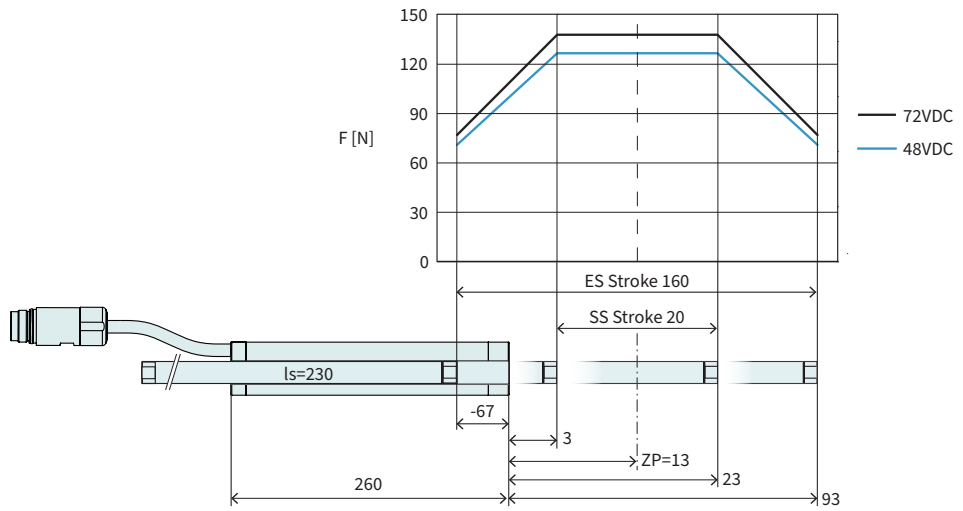

Dimensions mm

Technical Data P01-23x160H/20x160-HP-SSCP			
Stroke			
Standard Stroke (SS)	mm (in)	20	(0.79)
Extended Stroke (ES)	mm (in)	160	(6.29)
Force			
Max. Force @ 48VDC	N (lbf)	126	(28.32)
Max. Force @ 72VDC	N (lbf)	138	(31.02)
Max. Cont. Force without Mounting Flange [Passive cooling]	N (lbf)	21.5	(4.83)
Max. Cont. Force with Mounting Flange [Passive cooling/ Passive mounted ¹ / Cold Plate ²]	N (lbf)	23.5 / 30 / 35	(5.28 / 6.74 / 7.87)
Max. Border Force relative	%	56	
Force Constant	N/A _{pk} (lbf/A _{pk})	12.5	(2.81)
Velocity			
Max. Velocity @ 48VDC	m/s (in/s)	3.4	(133.9)
Max. Velocity @ 72VDC	m/s (in/s)	5.2	(204.7)
Position Detection			
Repeatability	mm (in)	±0.05	(±0.002)
Linearity	%	± 0.25	
Electrical Data			
Max. Current @ 48VDC	A _{pk}	10	
Max. Current @ 72VDC	A _{pk}	10	
Max. Cont. Current without Mounting Flange [Passive cooling]	A _{pk}	1.7	
Max. Cont. Current with Mounting Flange [Passive cooling/ Passive mounted ¹ / Cold Plate ²]	A _{pk}	1.9 / 2.4 / 2.9	
Thermal Data			
Max. Winding Temperature (Sensor)	°C	120	
Thermal Resistance without Mounting Flange [Passive cooling]	°K/W	5	
Thermal Resistance with [Passive cooling/ Passive mounted ¹ / Cold Plate ²]	°K/W	4.3 / 2.7 / 2	
Thermal Time Constant without Mounting Flange [Passive cooling]	s	600	
Thermal Time Constant with Mounting Flange [Passive cooling/ Passive mounted ¹ / Cold Plate ²]	s	800 / 1500 / 400	
Mechanical Data			
Slider Length	mm (in)	230	(9.1)
Slider Mass	g (lb)	180	(0.4)

1) Motor is mounted on a stainless steel surface of 0.03 m².
 2) Motor is mounted on a 20°C cold plate.

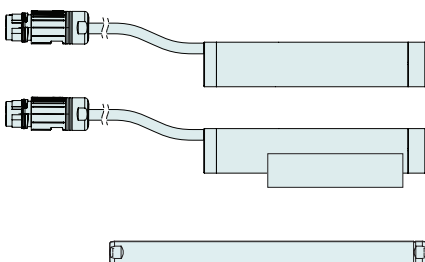

Item	Description	Item-No.
PS01-23x160H-HP-SSCP-R150	Stainless Steel Stator Performance, 1.5m Cable	Q150-4380
PS01-23x160H-HP-SSCP-G02-R150	Stainless Steel Stator Performance with Flange, 1.5m Cable	Q150-4473
PS01-23x160H-HP-SSCP-R20	Stainless Steel Stator Performance, 0.2m Cable, SSC-Plug	Q150-4381
PS01-23x160H-HP-SSCP-G02-R20	Stainless Steel Stator Perf. with Flange, 0.2m Cable, SSC-Plug	Q150-4474
PL01-12x230/190-HP-W01	Slider 'High Performance', HCR	Q150-4266
PL01-12x230/190-HP	Slider 'High Performance'	Q150-1519
PL02-12x230/190-HP	Slider 'heavy duty' 'High Performance'	Q150-1552
PL01-12x230/190-HP-L*	Slider 'High Performance L'	Q150-2546

* With this slider, the motor specifications above change.

P01-23x160H/60x200-HP-SSCP

Max. Stroke: 200 mm
Peak Force: 138 N

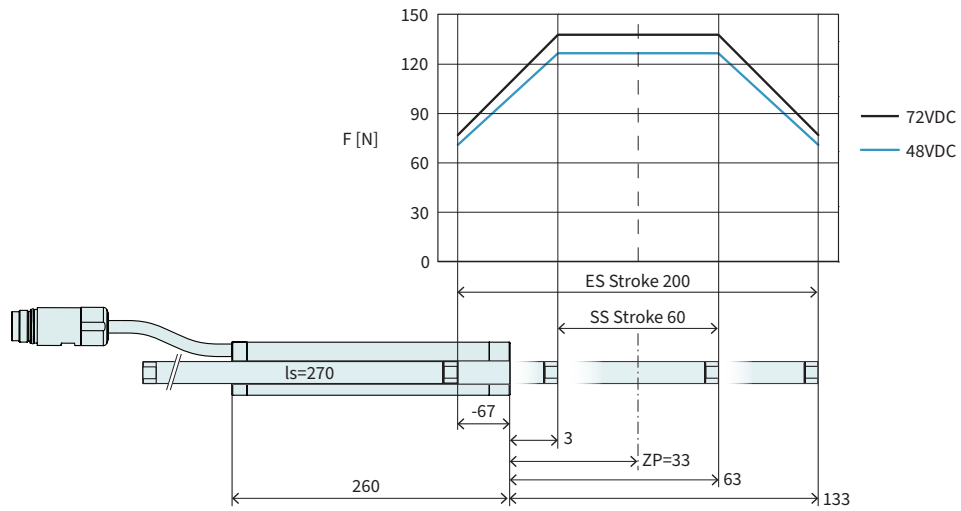

Dimensions mm

Technical Data P01-23x160H/60x200-HP-SSCP

Stroke				
Standard Stroke (SS)	mm	(in)	60	(2.36)
Extended Stroke (ES)	mm	(in)	200	(7.86)
Force				
Max. Force @ 48VDC	N	(lbf)	126	(28.32)
Max. Force @ 72VDC	N	(lbf)	138	(31.02)
Max. Cont. Force without Mounting Flange [Passive cooling]	N	(lbf)	21.5	(4.83)
Max. Cont. Force with Mounting Flange [Passive cooling/ Passive mounted ¹ / Cold Plate ²]	N	(lbf)	23.5 / 30 / 35	(5.28 / 6.74 / 7.87)
Max. Border Force relative	%		56	
Force Constant	N/A _{pk}	(lbf/A _{pk})	12.5	(2.81)
Velocity				
Max. Velocity @ 48VDC	m/s	(in/s)	3.4	(133.9)
Max. Velocity @ 72VDC	m/s	(in/s)	5.2	(204.7)
Position Detection				
Repeatability	mm	(in)	±0.05	(±0.002)
Linearity	%		± 0.2	
Electrical Data				
Max. Current @ 48VDC	A _{pk}		10	
Max. Current @ 72VDC	A _{pk}		10	
Max. Cont. Current without Mounting Flange [Passive cooling]	A _{pk}		1.7	
Max. Cont. Current with Mounting Flange [Passive cooling/ Passive mounted ¹ / Cold Plate ²]	A _{pk}		1.9 / 2.4 / 2.9	
Thermal Data				
Max. Winding Temperature (Sensor)	°C		120	
Thermal Resistance without Mounting Flange [Passive cooling]	*K/W		5	
Thermal Resistance with [Passive cooling/ Passive mounted ¹ / Cold Plate ²]	*K/W		4.3 / 2.7 / 2	
Thermal Time Constant without Mounting Flange [Passive cooling]	s		600	
Thermal Time Constant with Mounting Flange [Passive cooling/ Passive mounted ¹ / Cold Plate ²]	s		800 / 1500 / 400	
Mechanical Data				
Slider Length	mm	(in)	270	(11)
Slider Mass	g	(lb)	215	(0.47)

1) Motor is mounted on a stainless steel surface of 0.03 m².
 2) Motor is mounted on a 20°C cold plate.

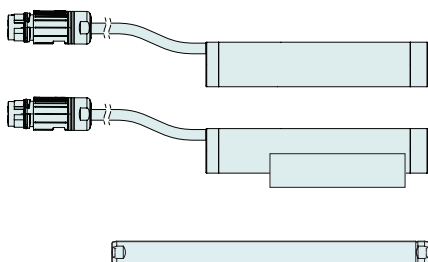

Item	Description	Item-No.
PS01-23x160H-HP-SSCP-R150	Stainless Steel Stator Performance, 1.5m Cable	0150-4380
PS01-23x160H-HP-SSCP-G02-R150	Stainless Steel Stator Performance with Flange, 1.5m Cable	0150-4473
PS01-23x160H-HP-SSCP-R20	Stainless Steel Stator Performance, 0.2m Cable, SSC-Plug	0150-4381
PS01-23x160H-HP-SSCP-G02-R20	Stainless Steel Stator Perf. with Flange, 0.2m Cable, SSC-Plug	0150-4474
PL01-12x270/230-HP-W01	Slider 'High Performance', HCR	0150-4267
PL01-12x270/230-HP	Slider 'High Performance'	0150-1520
PL02-12x270/230-HP	Slider 'heavy duty' 'High Performance'	0150-1533
PL01-12x270/230-HP-L*	Slider 'High Performance' L'	0150-2557

* With this slider, the motor specifications above change.

P01-23x160H/80x220-HP-SSCP

Max. Stroke: 220 mm
Peak Force: 138 N

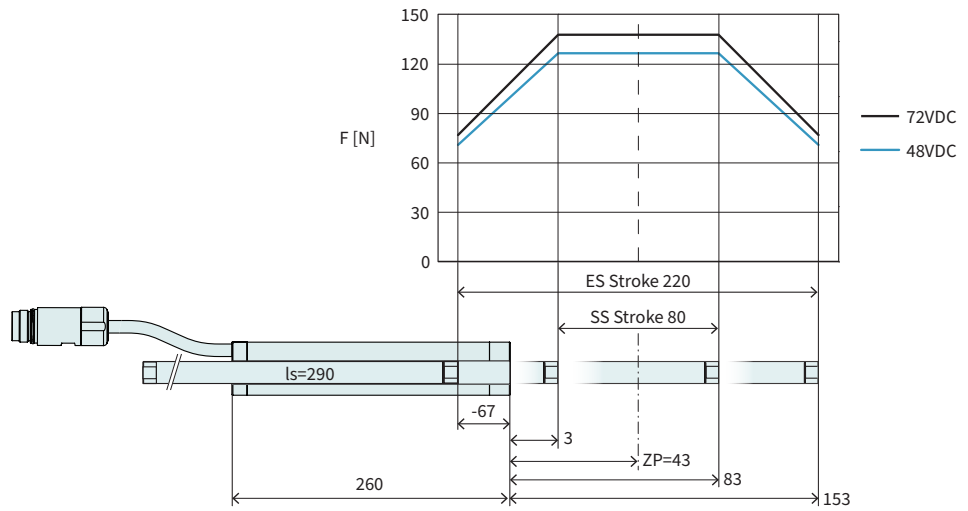

Dimensions mm

Technical Data P01-23x160H/80x220-HP-SSCP

Stroke			
Standard Stroke (SS)	mm (in)	80	(3.15)
Extended Stroke (ES)	mm (in)	220	(8.65)
Force			
Max. Force @ 48VDC	N (lbf)	126	(28.32)
Max. Force @ 72VDC	N (lbf)	138	(31.02)
Max. Cont. Force without Mounting Flange [Passive cooling]	N (lbf)	21.5	(4.83)
Max. Cont. Force with Mounting Flange [Passive cooling/ Passive mounted ¹ / Cold Plate ²]	N (lbf)	23.5 / 30 / 35	(5.28 / 6.74 / 7.87)
Max. Border Force relative	%	56	
Force Constant	N/A _{psl} (lbf/A _{psl})	12.5	(2.81)
Velocity			
Max. Velocity @ 48VDC	m/s (in/s)	3.4	(133.9)
Max. Velocity @ 72VDC	m/s (in/s)	5.2	(204.7)
Position Detection			
Repeatability	mm (in)	±0.05	(±0.002)
Linearity	%	± 0.2	
Electrical Data			
Max. Current @ 48VDC	A _{psl}	10	
Max. Current @ 72VDC	A _{psl}	10	
Max. Cont. Current without Mounting Flange [Passive cooling]	A _{psl}	1.7	
Max. Cont. Current with Mounting Flange [Passive cooling/ Passive mounted ¹ / Cold Plate ²]	A _{psl}	1.9 / 2.4 / 2.9	
Thermal Data			
Max. Winding Temperature (Sensor)	°C	120	
Thermal Resistance without Mounting Flange [Passive cooling]	°K/W	5	
Thermal Resistance with [Passive cooling/ Passive mounted ¹ / Cold Plate ²]	°K/W	4.3 / 2.7 / 2	
Thermal Time Constant without Mounting Flange [Passive cooling]	s	600	
Thermal Time Constant with Mounting Flange [Passive cooling/ Passive mounted ¹ / Cold Plate ²]	s	800 / 1500 / 400	
Mechanical Data			
Slider Length	mm (in)	290	(11)
Slider Mass	g (lb)	230	(0.51)

1) Motor is mounted on a stainless steel surface of 0.03 m².
 2) Motor is mounted on a 20°C cold plate.

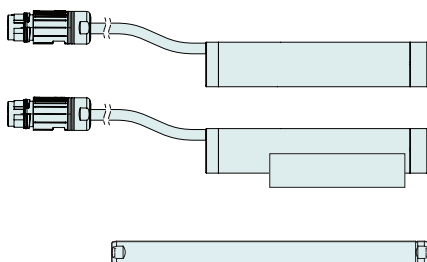

Item	Description	Item-No.
PS01-23x160H-HP-SSCP-R150	Stainless Steel Stator Performance, 1.5m Cable	Q150-4380
PS01-23x160H-HP-SSCP-G02-R150	Stainless Steel Stator Performance with Flange, 1.5m Cable	Q150-4473
PS01-23x160H-HP-SSCP-R20	Stainless Steel Stator Performance, 0.2m Cable, SSC-Plug	Q150-4381
PS01-23x160H-HP-SSCP-G02-R20	Stainless Steel Stator Perf. with Flange, 0.2m Cable, SSC-Plug	Q150-4474
PL01-12x290/250-HP-W01	Slider 'High Performance', HCR	Q150-4228
PL01-12x290/250-HP	Slider 'High Performance'	Q150-1521
PL02-12x290/250-HP	Slider 'heavy duty' 'High Performance'	Q150-1495
PL01-12x290/250-HP-L*	Slider 'High Performance L'	Q150-3690

* With this slider, the motor specifications above change.

P01-23x160H/140x280-HP-SSCP

Max. Stroke: 280 mm
Peak Force: 138 N

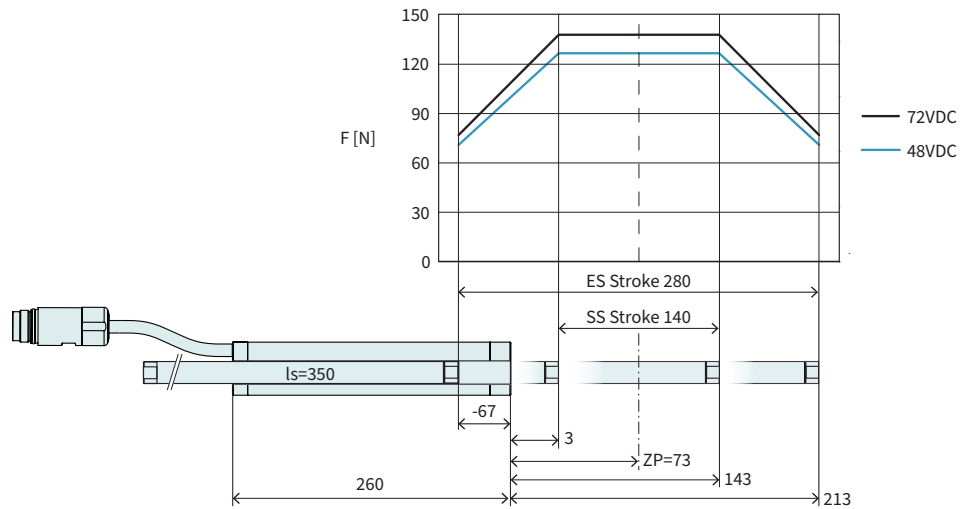

Dimensions mm

Technical Data P01-23x160H/140x280-HP-SSCP

Stroke			
Standard Stroke (SS)	mm (in)	140 (5.51)	
Extended Stroke (ES)	mm (in)	280 (10.99)	
Force			
Max. Force @ 48VDC	N (lbf)	126 (28.32)	
Max. Force @ 72VDC	N (lbf)	138 (31.02)	
Max. Cont. Force without Mounting Flange [Passive cooling]	N (lbf)	21.5 (4.83)	
Max. Cont. Force with Mounting Flange [Passive cooling/ Passive mounted ¹ / Cold Plate ²]	N (lbf)	23.5 / 30 / 35 (5.28 / 6.74 / 7.87)	
Max. Border Force relative	%	56	
Force Constant	N/A _{pk} (lbf/A _{pk})	12.5 (2.81)	
Velocity			
Max. Velocity @ 48VDC	m/s (in/s)	3.4 (133.9)	
Max. Velocity @ 72VDC	m/s (in/s)	5.2 (204.7)	
Position Detection			
Repeatability	mm (in)	±0.05 (±0.002)	
Linearity	%	± 0.2	
Electrical Data			
Max. Current @ 48VDC	A _{pk}	10	
Max. Current @ 72VDC	A _{pk}	10	
Max. Cont. Current without Mounting Flange [Passive cooling]	A _{pk}	1.7	
Max. Cont. Current with Mounting Flange [Passive cooling/ Passive mounted ¹ / Cold Plate ²]	A _{pk}	1.9 / 2.4 / 2.9	
Thermal Data			
Max. Winding Temperature (Sensor)	°C	120	
Thermal Resistance without Mounting Flange [Passive cooling]	°K/W	5	
Thermal Resistance with [Passive cooling/ Passive mounted ¹ / Cold Plate ²]	°K/W	4.3 / 2.7 / 2	
Thermal Time Constant without Mounting Flange [Passive cooling]	s	600	
Thermal Time Constant with Mounting Flange [Passive cooling/ Passive mounted ¹ / Cold Plate ²]	s	800 / 1500 / 400	
Mechanical Data			
Slider Length	mm (in)	350 (14)	
Slider Mass	g (lb)	280 (0.62)	

1) Motor is mounted on a stainless steel surface of 0.03 m².
 2) Motor is mounted on a 20°C cold plate.

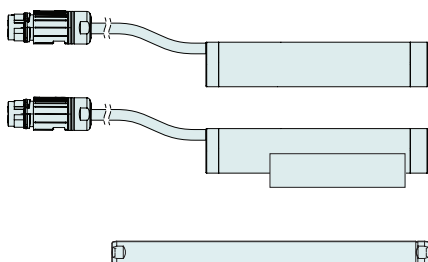

Item	Description	Item-No.
PS01-23x160H-HP-SSCP-R150	Stainless Steel Stator Performance, 1.5m Cable	0150-4380
PS01-23x160H-HP-SSCP-G02-R150	Stainless Steel Stator Performance with Flange, 1.5m Cable	0150-4473
PS01-23x160H-HP-SSCP-R20	Stainless Steel Stator Performance, 0.2m Cable, SSC-Plug	0150-4381
PS01-23x160H-HP-SSCP-G02-R20	Stainless Steel Stator Perf. with Flange, 0.2m Cable, SSC-Plug	0150-4474
PL01-12x350/310-HP-W01	Slider 'High Performance', HCR	0150-4268
PL01-12x350/310-HP	Slider 'High Performance'	0150-1522
PL02-12x350/310-HP	Slider 'heavy duty' 'High Performance'	0150-1555
PL01-12x350/310-HP-L	Slider 'High Performance' L'	0150-3691

* With this slider, the motor specifications above change.

P01-23x160H/210x350-HP-SSCP

Max. Stroke: 350 mm
Peak Force: 138 N

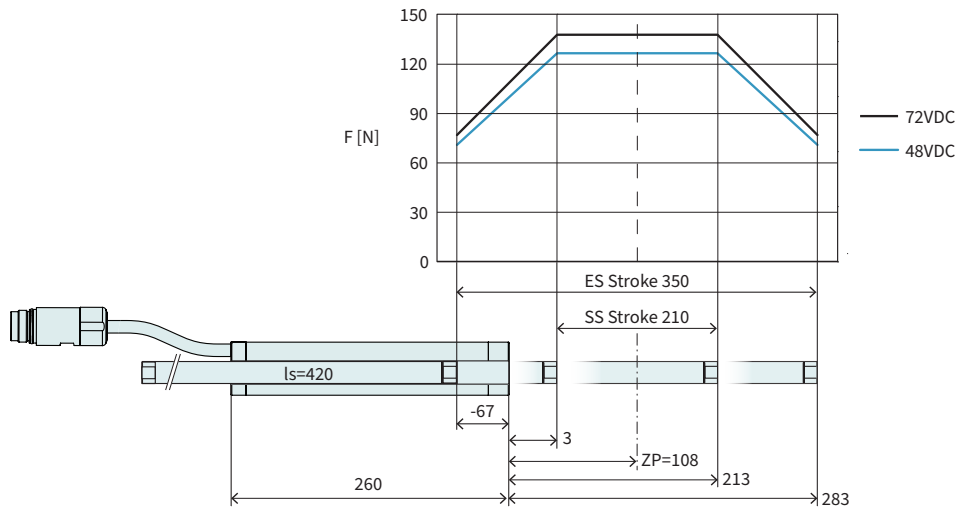

Dimensions mm

Technical Data P01-23x160H/210x350-HP-SSCP			
Stroke			
Standard Stroke (SS)	mm (in)	210	(8.27)
Extended Stroke (ES)	mm (in)	350	(13.8)
Force			
Max. Force @ 48VDC	N (lbf)	126	(28.32)
Max. Force @ 72VDC	N (lbf)	138	(31.02)
Max. Cont. Force without Mounting Flange [Passive cooling]	N (lbf)	21.5	(4.83)
Max. Cont. Force with Mounting Flange [Passive cooling/ Passive mounted ¹ / Cold Plate ²]	N (lbf)	23.5 / 30 / 35	(5.28 / 6.74 / 7.87)
Max. Border Force relative	%	56	
Force Constant	N/A _{pk} (lbf/A _{pk})	12.5	(2.81)
Velocity			
Max. Velocity @ 48VDC	m/s (in/s)	3.4	(133.9)
Max. Velocity @ 72VDC	m/s (in/s)	5.2	(204.7)
Position Detection			
Repeatability	mm (in)	±0.05	(±0.002)
Linearity	%	± 0.15	
Electrical Data			
Max. Current @ 48VDC	A _{pk}	10	
Max. Current @ 72VDC	A _{pk}	10	
Max. Cont. Current without Mounting Flange [Passive cooling]	A _{pk}	1.7	
Max. Cont. Current with Mounting Flange [Passive cooling/ Passive mounted ¹ / Cold Plate ²]	A _{pk}	1.9 / 2.4 / 2.9	
Thermal Data			
Max. Winding Temperature (Sensor)	°C	120	
Thermal Resistance without Mounting Flange [Passive cooling]	*K/W	5	
Thermal Resistance with [Passive cooling/ Passive mounted ¹ / Cold Plate ²]	*K/W	4.3 / 2.7 / 2	
Thermal Time Constant without Mounting Flange [Passive cooling]	s	600	
Thermal Time Constant with Mounting Flange [Passive cooling/ Passive mounted ¹ / Cold Plate ²]	s	800 / 1500 / 400	
Mechanical Data			
Slider Length	mm (in)	420	(17)
Slider Mass	g (lb)	340	(0.75)

1) Motor is mounted on a stainless steel surface of 0.03 m².
 2) Motor is mounted on a 20°C cold plate.

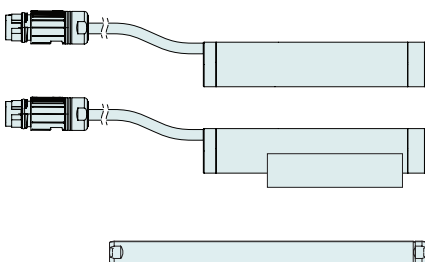

Item	Description	Item-No.
PS01-23x160H-HP-SSCP-R150	Stainless Steel Stator Performance, 1.5m Cable	Q150-4380
PS01-23x160H-HP-SSCP-G02-R150	Stainless Steel Stator Performance with Flange, 1.5m Cable	Q150-4473
PS01-23x160H-HP-SSCP-R20	Stainless Steel Stator Performance, 0.2m Cable, SSC-Plug	Q150-4381
PS01-23x160H-HP-SSCP-G02-R20	Stainless Steel Stator Perf. with Flange, 0.2m Cable, SSC-Plug	Q150-4474
PL01-12x420/380-HP-W01	Slider 'High Performance', HCR	Q150-4269
PL01-12x420/380-HP	Slider 'High Performance'	Q150-1523
PL02-12x420/380-HP	Slider 'heavy duty' 'High Performance'	Q150-1554
PL01-12x420/380-HP-L	Slider 'High Performance L'	Q150-3692

* With this slider, the motor specifications above change.

P01-23x160H/270x410-HP-SSCP

Max. Stroke: 410 mm
Peak Force: 138 N

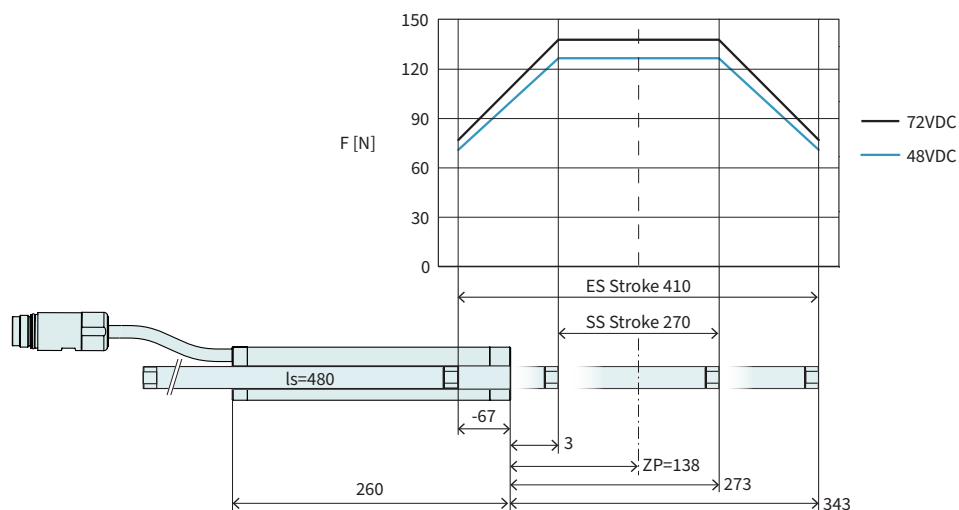

Dimensions mm

Technical Data P01-23x160H/270x410-HP-SSCP

Stroke				
Standard Stroke (SS)	mm	(in)	270	(10.63)
Extended Stroke (ES)	mm	(in)	410	(16.14)
Force				
Max. Force @ 48VDC	N	(lbf)	126	(28.32)
Max. Force @ 72VDC	N	(lbf)	138	(31.02)
Max. Cont. Force without Mounting Flange [Passive cooling]	N	(lbf)	21.5	(4.83)
Max. Cont. Force with Mounting Flange [Passive cooling / Passive mounted ¹ / Cold Plate ²]	N	(lbf)	23.5 / 30 / 35	(5.28 / 6.74 / 7.87)
Max. Border Force relative	%		56	
Force Constant	N/A _{pk}	(lbf/A _{pk})	12.5	(2.81)
Velocity				
Max. Velocity @ 48VDC	m/s	(in/s)	3.4	(133.9)
Max. Velocity @ 72VDC	m/s	(in/s)	5.2	(204.7)
Position Detection				
Repeatability	mm	(in)	±0.05	(±0.002)
Linearity	%		± 0.15	
Electrical Data				
Max. Current @ 48VDC	A _{pk}		10	
Max. Current @ 72VDC	A _{pk}		10	
Max. Cont. Current without Mounting Flange [Passive cooling]	A _{pk}		1.7	
Max. Cont. Current with Mounting Flange [Passive cooling / Passive mounted ¹ / Cold Plate ²]	A _{pk}		1.9 / 2.4 / 2.9	
Thermal Data				
Max. Winding Temperature (Sensor)	°C		120	
Thermal Resistance without Mounting Flange [Passive cooling]	°K/W		5	
Thermal Resistance with [Passive cooling / Passive mounted ¹ / Cold Plate ²]	°K/W		4.3 / 2.7 / 2	
Thermal Time Constant without Mounting Flange [Passive cooling]	s		600	
Thermal Time Constant with Mounting Flange [Passive cooling / Passive mounted ¹ / Cold Plate ²]	s		800 / 1500 / 400	
Mechanical Data				
Slider Length	mm	(in)	480	(19)
Slider Mass	g	(lb)	390	(0.86)

1) Motor is mounted on a stainless steel surface of 0.03 m².
 2) Motor is mounted on a 20°C cold plate.

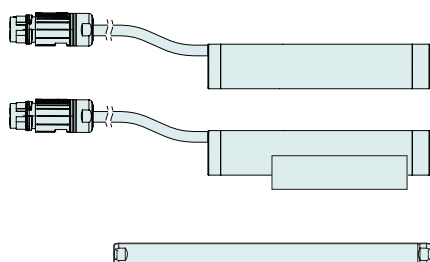

Item	Description	Item-No.
PS01-23x160H-HP-SSCP-R150	Stainless Steel Stator Performance, 1.5m Cable	0150-4380
PS01-23x160H-HP-SSCP-G02-R150	Stainless Steel Stator Performance with Flange, 1.5m Cable	0150-4473
PS01-23x160H-HP-SSCP-R20	Stainless Steel Stator Performance, 0.2m Cable, SSC-Plug	0150-4381
PS01-23x160H-HP-SSCP-G02-R20	Stainless Steel Stator Perf. with Flange, 0.2m Cable, SSC-Plug	0150-4474
PL01-12x480/440-HP-W01	Slider 'High Performance', HCR	0150-4270
PL01-12x480/440-HP	Slider 'High Performance'	0150-1524
PL02-12x480/440-HP	Slider 'heavy duty' 'High Performance'	0150-2519
PL01-12x480/440-HP-L	Slider 'High Performance' L'	0150-3693

* With this slider, the motor specifications above change.

P01-23x160H/370x510-HP-SSCP

Max. Stroke: 510 mm
Peak Force: 138 N

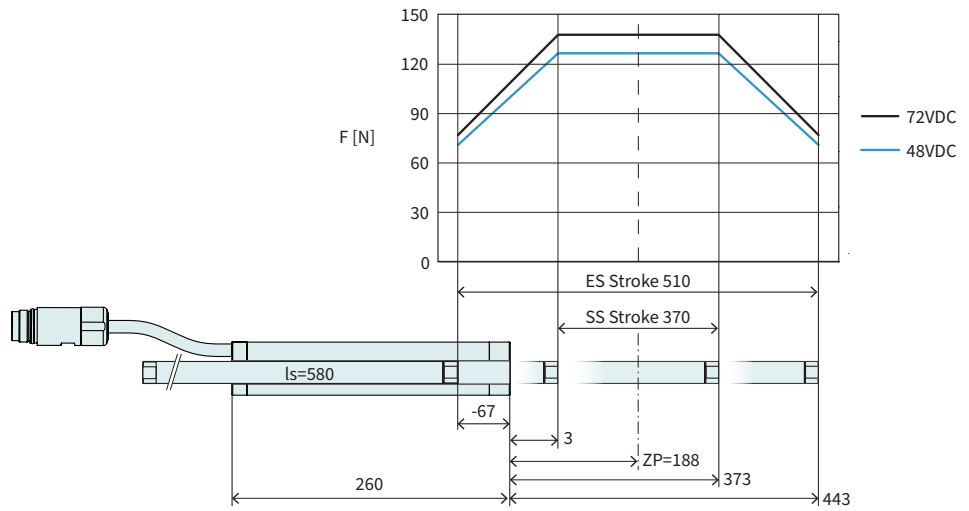

Dimensions mm

Technical Data P01-23x160H/370x510-HP-SSCP

Stroke			
Standard Stroke (SS)	mm (in)	370	(14.57)
Extended Stroke (ES)	mm (in)	510	(20.08)
Force			
Max. Force @ 48VDC	N (lbf)	126	(28.32)
Max. Force @ 72VDC	N (lbf)	138	(31.02)
Max. Cont. Force without Mounting Flange [Passive cooling]	N (lbf)	21.5	(4.83)
Max. Cont. Force with Mounting Flange [Passive cooling/ Passive mounted ¹ / Cold Plate ²]	N (lbf)	23.5 / 30 / 35	(5.28 / 6.74 / 7.87)
Max. Border Force relative	%	56	
Force Constant	N/A _{pk} (lbf/A _{pk})	12.5	(2.81)
Velocity			
Max. Velocity @ 48VDC	m/s (in/s)	3.4	(133.9)
Max. Velocity @ 72VDC	m/s (in/s)	5.2	(204.7)
Position Detection			
Repeatability	mm (in)	±0.05	(±0.002)
Linearity	%	± 0.15	
Electrical Data			
Max. Current @ 48VDC	A _{pk}	10	
Max. Current @ 72VDC	A _{pk}	10	
Max. Cont. Current without Mounting Flange [Passive cooling]	A _{pk}	1.7	
Max. Cont. Current with Mounting Flange [Passive cooling/ Passive mounted ¹ / Cold Plate ²]	A _{pk}	1.9 / 2.4 / 2.9	
Thermal Data			
Max. Winding Temperature (Sensor)	°C	120	
Thermal Resistance without Mounting Flange [Passive cooling]	°K/W	5	
Thermal Resistance with [Passive cooling/ Passive mounted ¹ / Cold Plate ²]	°K/W	4.3 / 2.7 / 2	
Thermal Time Constant without Mounting Flange [Passive cooling]	s	600	
Thermal Time Constant with Mounting Flange [Passive cooling/ Passive mounted ¹ / Cold Plate ²]	s	800 / 1500 / 400	
Mechanical Data			
Slider Length	mm (in)	580	(23)
Slider Mass	g (lb)	480	(1.06)

1) Motor is mounted on a stainless steel surface of 0.03 m².
 2) Motor is mounted on a 20°C cold plate.

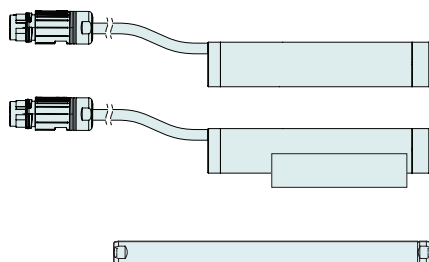

Item	Description	Item-No.
PS01-23x160H-HP-SSCP-R150	Stainless Steel Stator Performance, 1.5m Cable	Q150-4380
PS01-23x160H-HP-SSCP-G02-R150	Stainless Steel Stator Performance with Flange, 1.5m Cable	Q150-4473
PS01-23x160H-HP-SSCP-R20	Stainless Steel Stator Performance, 0.2m Cable, SSC-Plug	Q150-4381
PS01-23x160H-HP-SSCP-G02-R20	Stainless Steel Stator Perf. with Flange, 0.2m Cable, SSC-Plug	Q150-4474
PL01-12x580/540-HP-W01	Slider 'High Performance', HCR	Q150-4271
PL01-12x580/540-HP	Slider 'High Performance'	Q150-1525
PL02-12x580/540-HP	Slider 'heavy duty' 'High Performance'	Q150-2520
PL01-12x580/540-HP-L	Slider 'High Performance L'	Q150-3694

* With this slider, the motor specifications above change.

P01-23x160H/480x620-HP-SSCP

Max. Stroke: 620 mm
Peak Force: 138 N

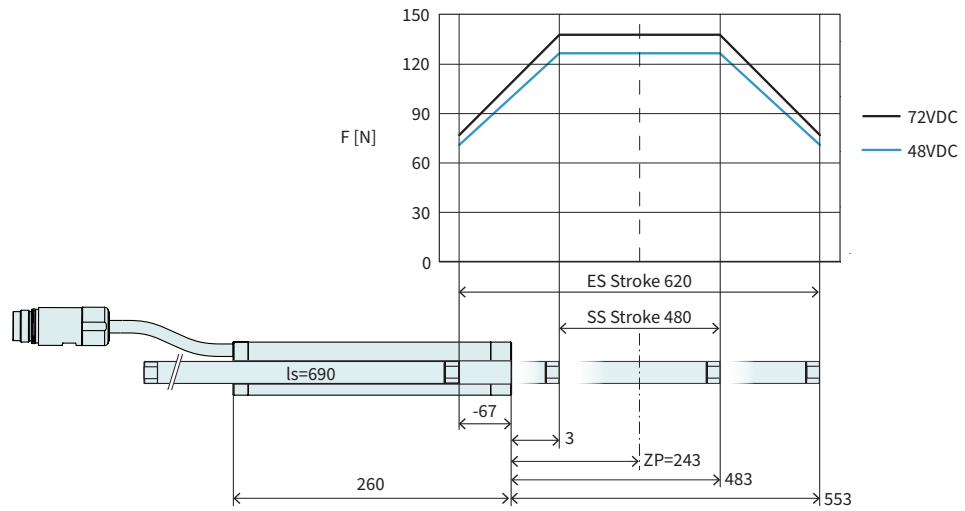

Dimensions mm

Technical Data P01-23x160H/480x620-HP-SSCP

Stroke				
Standard Stroke (SS)	mm	(in)	480	(18.89)
Extended Stroke (ES)	mm	(in)	620	(24.41)
Force				
Max. Force @ 48VDC	N	(lbf)	126	(28.32)
Max. Force @ 72VDC	N	(lbf)	138	(31.02)
Max. Cont. Force without Mounting Flange [Passive cooling]	N	(lbf)	21.5	(4.83)
Max. Cont. Force with Mounting Flange [Passive cooling / Passive mounted ¹ / Cold Plate ²]	N	(lbf)	23.5 / 30 / 35	(5.28 / 6.74 / 7.87)
Max. Border Force relative	%		56	
Force Constant	N/A _{pk}	(lbf/A _{pk})	12.5	(2.81)
Velocity				
Max. Velocity @ 48VDC	m/s	(in/s)	3.4	(133.9)
Max. Velocity @ 72VDC	m/s	(in/s)	5.2	(204.7)
Position Detection				
Repeatability	mm	(in)	±0.05	(±0.002)
Linearity	%		± 0.15	
Electrical Data				
Max. Current @ 48VDC	A _{pk}		10	
Max. Current @ 72VDC	A _{pk}		10	
Max. Cont. Current without Mounting Flange [Passive cooling]	A _{pk}		1.7	
Max. Cont. Current with Mounting Flange [Passive cooling / Passive mounted ¹ / Cold Plate ²]	A _{pk}		1.9 / 2.4 / 2.9	
Thermal Data				
Max. Winding Temperature (Sensor)	°C		120	
Thermal Resistance without Mounting Flange [Passive cooling]	°K/W		5	
Thermal Resistance with [Passive cooling / Passive mounted ¹ / Cold Plate ²]	°K/W		4.3 / 2.7 / 2	
Thermal Time Constant without Mounting Flange [Passive cooling]	s		600	
Thermal Time Constant with Mounting Flange [Passive cooling / Passive mounted ¹ / Cold Plate ²]	s		800 / 1500 / 400	
Mechanical Data				
Slider Length	mm	(in)	690	(27.17)
Slider Mass	g	(lb)	570	(1.26)

1) Motor is mounted on a stainless steel surface of 0.03 m².
 2) Motor is mounted on a 20°C cold plate.

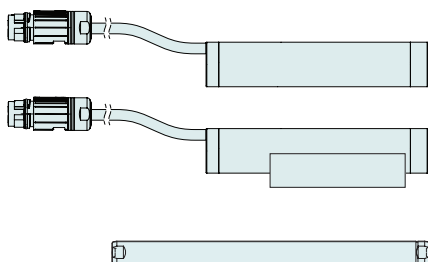

Item	Description	Item-No.
PS01-23x160H-HP-SSCP-R150	Stainless Steel Stator Performance, 1.5m Cable	0150-4380
PS01-23x160H-HP-SSCP-G02-R150	Stainless Steel Stator Performance with Flange, 1.5m Cable	0150-4473
PS01-23x160H-HP-SSCP-R20	Stainless Steel Stator Performance, 0.2m Cable, SSC-Plug	0150-4381
PS01-23x160H-HP-SSCP-G02-R20	Stainless Steel Stator Perf. with Flange, 0.2m Cable, SSC-Plug	0150-4474
PL01-12x690/650-HP-W01	Slider 'High Performance', HCR	0150-4522
PL01-12x690/650-HP	Slider 'High Performance'	0150-2646
PL02-12x690/650-HP	Slider 'heavy duty' 'High Performance'	0150-4559
PL01-12x690/650-HP-L	Slider 'High Performance' L'	0150-4521

* With this slider, the motor specifications above change.

P01-23x160H/550x690-HP-SSCP

Max. Stroke: 690 mm
Peak Force: 138 N

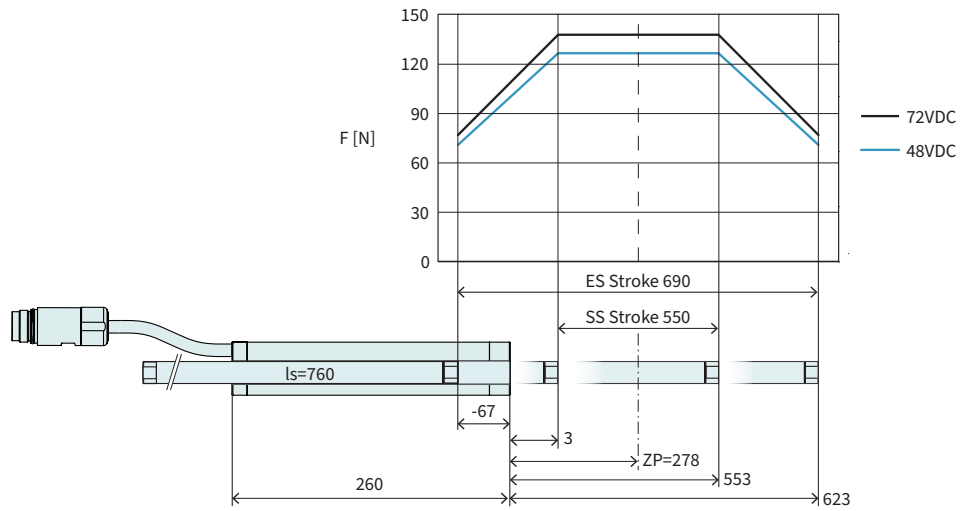

Dimensions mm

Technical Data P01-23x160H/550x690-HP-SSCP			
Stroke			
Standard Stroke (SS)	mm (in)	550	(21.65)
Extended Stroke (ES)	mm (in)	690	(27.19)
Force			
Max. Force @ 48VDC	N (lbf)	126	(28.32)
Max. Force @ 72VDC	N (lbf)	138	(31.02)
Max. Cont. Force without Mounting Flange [Passive cooling]	N (lbf)	21.5	(4.83)
Max. Cont. Force with Mounting Flange [Passive cooling/ Passive mounted ¹ / Cold Plate ²]	N (lbf)	23.5 / 30 / 35	(5.28 / 6.74 / 7.87)
Max. Border Force relative	%	56	
Force Constant	N/A _{psk} (lbf/A _{psk})	12.5	(2.81)
Velocity			
Max. Velocity @ 48VDC	m/s (in/s)	3.4	(133.9)
Max. Velocity @ 72VDC	m/s (in/s)	5.2	(204.7)
Position Detection			
Repeatability	mm (in)	±0.05	(±0.002)
Linearity	%	± 0.15	
Electrical Data			
Max. Current @ 48VDC	A _{psk}	10	
Max. Current @ 72VDC	A _{psk}	10	
Max. Cont. Current without Mounting Flange [Passive cooling]	A _{psk}	1.7	
Max. Cont. Current with Mounting Flange [Passive cooling/ Passive mounted ¹ / Cold Plate ²]	A _{psk}	1.9 / 2.4 / 2.9	
Thermal Data			
Max. Winding Temperature (Sensor)	°C	120	
Thermal Resistance without Mounting Flange [Passive cooling]	°K/W	5	
Thermal Resistance with [Passive cooling/ Passive mounted ¹ / Cold Plate ²]	°K/W	4.3 / 2.7 / 2	
Thermal Time Constant without Mounting Flange [Passive cooling]	s	600	
Thermal Time Constant with Mounting Flange [Passive cooling/ Passive mounted ¹ / Cold Plate ²]	s	800 / 1500 / 400	
Mechanical Data			
Slider Length	mm (in)	760	(30)
Slider Mass	g (lb)	630	(1.4)

1) Motor is mounted on a stainless steel surface of 0.03 m².
 2) Motor is mounted on a 20°C cold plate.

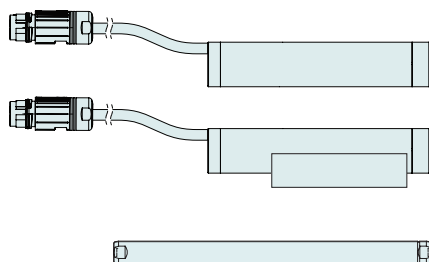

Item	Description	Item-No.
PS01-23x160H-HP-SSCP-R150	Stainless Steel Stator Performance, 1.5m Cable	Q150-4380
PS01-23x160H-HP-SSCP-G02-R150	Stainless Steel Stator Performance with Flange, 1.5m Cable	Q150-4473
PS01-23x160H-HP-SSCP-R20	Stainless Steel Stator Performance, 0.2m Cable, SSC-Plug	Q150-4381
PS01-23x160H-HP-SSCP-G02-R20	Stainless Steel Stator Perf. with Flange, 0.2m Cable, SSC-Plug	Q150-4474
PL01-12x760/720-HP-W01	Slider 'High Performance', HCR	Q150-4272
PL01-12x760/720-HP	Slider 'High Performance'	Q150-1526
PL02-12x760/720-HP	Slider 'heavy duty' 'High Performance'	Q150-2521
PL01-12x760/720-HP-L	Slider 'High Performance L'	Q150-3695

* With this slider, the motor specifications above change.

P01-23x160H/640x780-HP-SSCP

Max. Stroke: 780 mm
Peak Force: 138 N

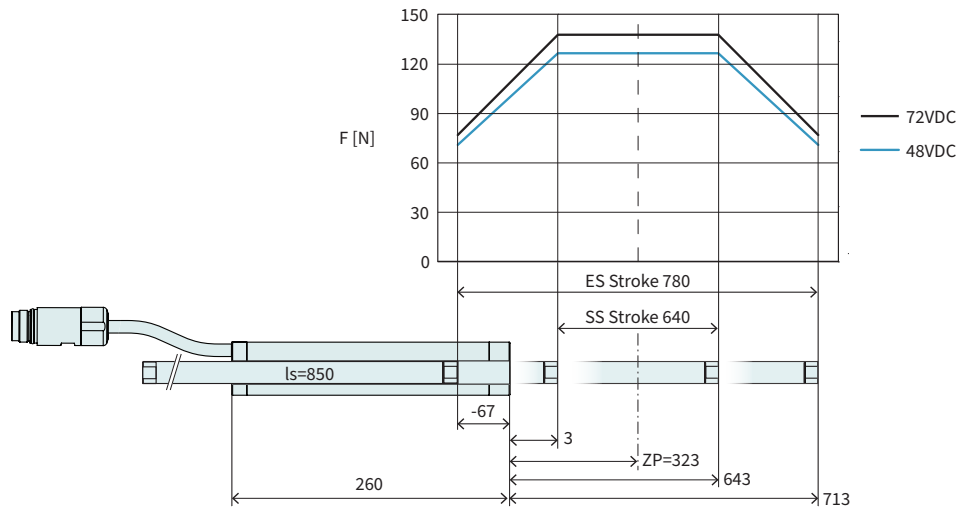

Dimensions mm

Technical Data P01-23x160H/640x780-HP-SSCP

Stroke				
Standard Stroke (SS)	mm	(in)	640	(25.20)
Extended Stroke (ES)	mm	(in)	780	(30.69)
Force				
Max. Force @ 48VDC	N	(lbf)	126	(28.32)
Max. Force @ 72VDC	N	(lbf)	138	(31.02)
Max. Cont. Force without Mounting Flange [Passive cooling]	N	(lbf)	21.5	(4.83)
Max. Cont. Force with Mounting Flange [Passive cooling / Passive mounted ¹ / Cold Plate ²]	N	(lbf)	23.5 / 30 / 35	(5.28 / 6.74 / 7.87)
Max. Border Force relative	%		56	
Force Constant	N/A _{pk}	(lbf/A _{pk})	12.5	(2.81)
Velocity				
Max. Velocity @ 48VDC	m/s	(in/s)	3.4	(133.9)
Max. Velocity @ 72VDC	m/s	(in/s)	5.2	(204.7)
Position Detection				
Repeatability	mm	(in)	±0.05	(±0.002)
Linearity	%		± 0.15	
Electrical Data				
Max. Current @ 48VDC	A _{pk}		10	
Max. Current @ 72VDC	A _{pk}		10	
Max. Cont. Current without Mounting Flange [Passive cooling]	A _{pk}		1.7	
Max. Cont. Current with Mounting Flange [Passive cooling / Passive mounted ¹ / Cold Plate ²]	A _{pk}		1.9 / 2.4 / 2.9	
Thermal Data				
Max. Winding Temperature (Sensor)	°C		120	
Thermal Resistance without Mounting Flange [Passive cooling]	°K/W		5	
Thermal Resistance with [Passive cooling / Passive mounted ¹ / Cold Plate ²]	°K/W		4.3 / 2.7 / 2	
Thermal Time Constant without Mounting Flange [Passive cooling]	s		600	
Thermal Time Constant with Mounting Flange [Passive cooling / Passive mounted ¹ / Cold Plate ²]	s		800 / 1500 / 400	
Mechanical Data				
Slider Length	mm	(in)	850	(33)
Slider Mass	g	(lb)	700	(1.5)

1) Motor is mounted on a stainless steel surface of 0.03 m².
 2) Motor is mounted on a 20°C cold plate.

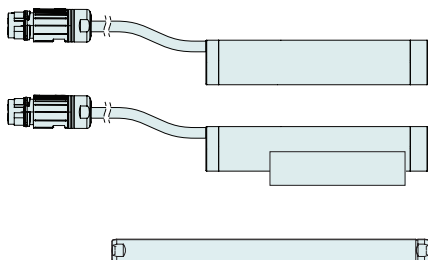

Item	Description	Item-No.
PS01-23x160H-HP-SSCP-R150	Stainless Steel Stator Performance, 1.5m Cable	0150-4380
PS01-23x160H-HP-SSCP-G02-R150	Stainless Steel Stator Performance with Flange, 1.5m Cable	0150-4473
PS01-23x160H-HP-SSCP-R20	Stainless Steel Stator Performance, 0.2m Cable, SSC-Plug	0150-4381
PS01-23x160H-HP-SSCP-G02-R20	Stainless Steel Stator Perf. with Flange, 0.2m Cable, SSC-Plug	0150-4474
PL01-12x850/810-HP-W01	Slider 'High Performance', HCR	0150-4273
PL01-12x850/810-HP	Slider 'High Performance'	0150-1527
PL02-12x850/810-HP	Slider 'heavy duty' 'High Performance'	0150-2516
PL01-12x850/810-HP-L	Slider 'High Performance' L'	On request

* With this slider, the motor specifications above change.

Motor Cable

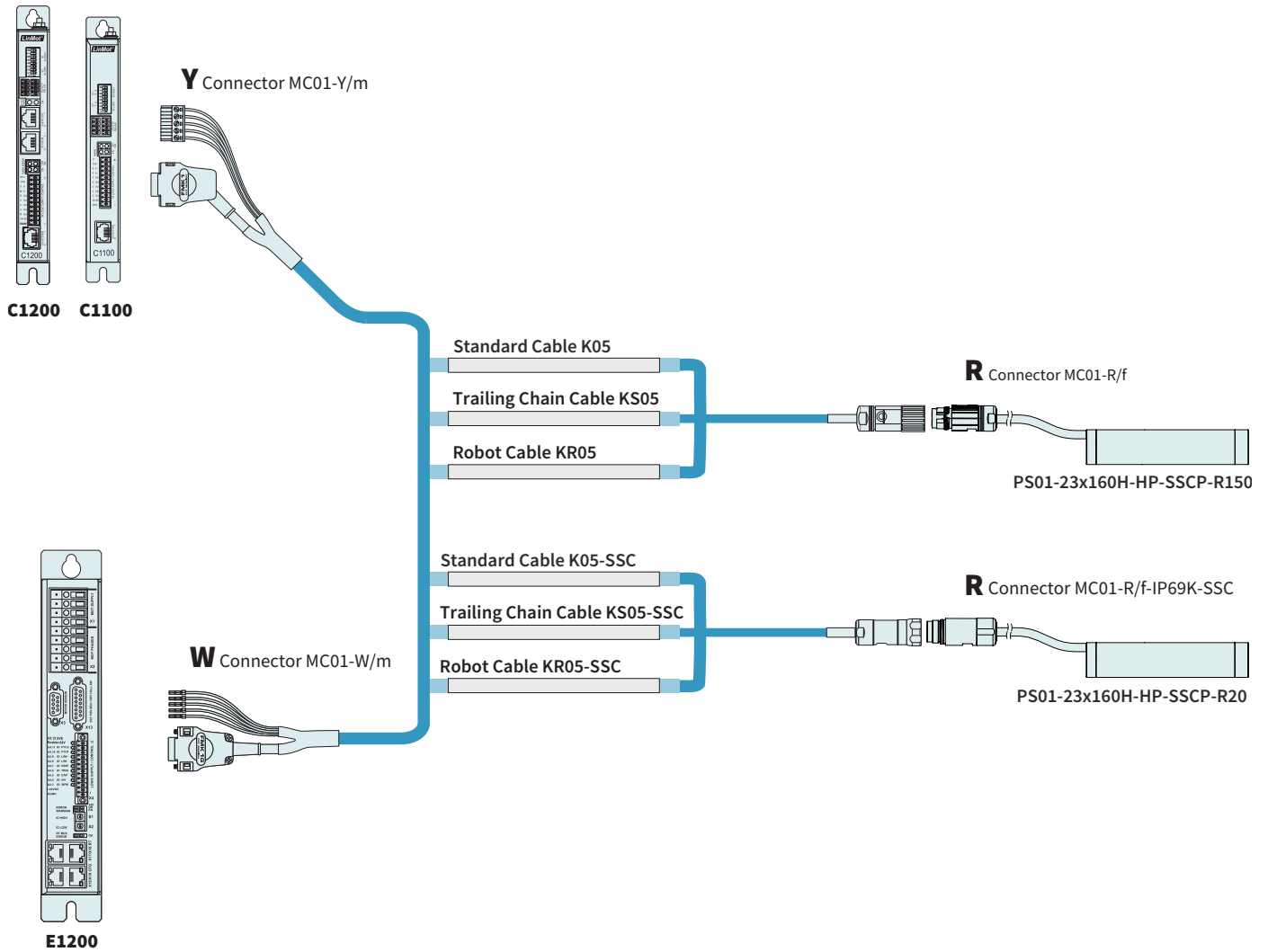

Note: Linear Motor does not run on servo drive series E100 and E1000 as well as on the series B1100 and E1100.

ORDERING INFORMATION

STANDARD CABLE		
Item	Description	Item-No.
K05-W/R-2	Motor Cable W/R, 2 m	0150-2119
K05-W/R-4	Motor Cable W/R, 4 m	0150-2120
K05-W/R-6	Motor Cable W/R, 6 m	0150-2121
K05-W/R-8	Motor Cable W/R, 8 m	0150-2122
K05-W/R-	Motor Cable W/R, Custom length	0150-3262
K05-Y/R-2	Motor Cable Y/R, 2 m	0150-2421
K05-Y/R-4	Motor Cable Y/R, 4 m	0150-2422
K05-Y/R-6	Motor Cable Y/R, 6 m	0150-2423
K05-Y/R-8	Motor Cable Y/R, 8 m	0150-2424
K05-Y-Fe/R-	Motor Cable Y/R, Custom length	0150-3501
K05-W/R-SSC-	Trailing Chain Cable W/R-SSC, Custom length	0150-3586
K05-Y-Fe/R-SSC-	Trailing Chain Cable Y-Fe/R-SSC, Custom length	0150-3715

TRAILING CHAIN CABLE

Item	Description	Item-No.
KS05-W/R-4	Trailing Chain Cable W/R, 4 m	0150-2106
KS05-W/R-6	Trailing Chain Cable W/R, 6 m	0150-2131
KS05-W/R-8	Trailing Chain Cable W/R, 8 m	0150-2107
KS05-W/R-	Trailing Chain Cable W/R, Custom length	0150-3256
KS05-Y/R-2	Trailing Chain Cable Y/R, 2 m	0150-4165
KS05-Y/R-4	Trailing Chain Cable Y/R, 4 m	0150-2433
KS05-Y/R-6	Trailing Chain Cable Y/R, 6 m	0150-2434
KS05-Y/R-8	Trailing Chain Cable Y/R, 8 m	0150-2435
KS05-Y-Fe/R-	Trailing Chain Cable Y-Fe/R, Custom length	0150-3507
KS05-W/R-SSC-2	Trailing Chain Cable W/R-SSC, 2 m	0150-2683
KS05-W/R-SSC-4	Trailing Chain Cable W/R-SSC, 4 m	0150-2684
KS05-W/R-SSC-6	Trailing Chain Cable W/R-SSC, 6 m	0150-2685
KS05-W/R-SSC-8	Trailing Chain Cable W/R-SSC, 8 m	0150-2686
KS05-W/R-SSC-	Trailing Chain Cable W/R-SSC, Custom length	0150-3583
KS05-Y/R-SSC-2	Trailing Chain Cable Y/R-SSC, 2 m	0150-2687
KS05-Y/R-SSC-4	Trailing Chain Cable Y/R-SSC, 4 m	0150-2688
KS05-Y/R-SSC-6	Trailing Chain Cable Y/R-SSC, 6 m	0150-2689
KS05-Y/R-SSC-8	Trailing Chain Cable Y/R-SSC, 8 m	0150-2690
KS05-Y-Fe/R-SSC-	Trailing Chain Cable Y-Fe/R-SSC, Custom length	0150-3646

ROBOT CABLE

Item	Description	Item-No.
KR05-W/R-	Robot Cable KR05-W/R, Custom length	0150-3336
KR05-Y-Fe/R-	Robot Cable KR05-Y-Fe/R, Custom length	0150-3512
KR05-W/R-SSC-	Robot Cable KR05-W/R-SSC-, Custom length	0150-3587
KR05-Y-Fe/R-SSC-	Robot Cable KR05-Y-Fe/R-SSC-, Custom length	0150-4364

CONNECTOR & CABLE (INDIVIDUAL)

Item	Description	Item-No.
MC01-W/m	Motor Connector W/m	0150-3140
MC01-Y-Fe/m	Motor Connector Y-Fe/m	0150-3289
MC01-R/f	Motor Connector R/f	0150-3129
MC01-R/f-IP69K-SSC	Motor Connector R/f, IP69k, SSC	0150-3347
KS05-04/05	Trailing Chain Cable per m	0150-1938
KS05-04/05	Trailing Chain Cable per m	0150-1938
KR05-04/05	Robot Cable per m	0150-1846

SLIDER MOUNTING



Item	Description	Item-No.
PLF01-12-Ni	Fixed Bearing Set for 12 mm sliders, nickel-plated	0150-3573

FIND MORE PRODUCT DETAILS IN THE CHAPTER "ACCESSORIES".

Area with horizontal dotted lines for notes.