

Installation Guide Linear Motors

ENG

P01-48-HP EX protected



Content

1	General information	4
1.1	Introduction	4
1.2	Explanation of symbols	4
1.3	Qualified personnel	4
1.4	Liability	4
1.5	Copyright	4
2	Safety instructions	5
2.1	Appropriate application	5
2.2	Warning signs	6
2.3	Additional ATEX safety instructions	8
3	Product description	9
3.1	Structure	9
3.1.1	Linear Motor	9
3.1.2	LinMot Servo Drive	9
3.1.3	Temperature relay	10
3.1.4	Circuit breaker	10
3.2	Exterior view	10
3.3	Interior view	11
3.4	Technical data	11
3.5	Performance characteristic	16
3.6	Thermal behavior	16
3.6.1	Internal temperature monitoring	16
3.6.2	Higher-level temperature monitoring	18
3.7	Dimensions	19
3.7.1	PS01-48x150 with bearing PB01	19
3.7.2	PS01-48x150 with bearing flange PB03	20
3.7.3	PS01-48x240 with bearing PB01	21
3.7.4	PS01-48x240 with bearing flange PB03	22
3.7.5	PS01-48x360 with bearing PB01	23
3.7.6	PS01-48x360 with bearing flange PB03	24
3.8	Marking	25
3.9	Connector assignment	25
3.10	Motor cable	26
3.11	Cabling	27
4	Installation and commissioning	27
4.1	Operating conditions	27
4.2	Mounting the motor	28
4.3	Mounting the flange	29
4.4	Mounting the payload to the slider	29
4.5	«Moving slider» installation	30
4.6	Electrical connection of the motor	31
4.7	Check before commissioning	32

4.8	Design of water cooling	32
4.8.1	Determination of the max. possible amount of cont. power dissipation P_{v_Max}	33
4.8.2	Determination of water flow Q	33
4.8.3	Determination of water pressure Δp	34
4.8.4	Corrosion protection.....	34
4.8.5	Cooling line connection.....	34
5	Accessories	35
5.1	Slider mounting kit fixed bearing	35
5.2	Cooling Flange.....	35
6	Maintenance and test instructions	36
6.1	Maintenance schedule.....	36
6.2	Cleaning in assembled state	37
6.3	Cleaning in disassembled state.....	37
6.4	Cleaning agent.....	37
6.5	Stator checking	37
7	Storage, transport, installation height	39
8	Declaration of Conformity	40
9	IECEX Conformity certificate.....	41
10	EC Type examination certificate	45

1 General information

1.1 Introduction

This manual includes instructions for the assembly, installation, maintenance, transport, and storage of linear motors. The document is intended for electricians, mechanics, service technicians, and warehouse staff. Read this manual before using the product and observe the general safety instructions and those in the relevant section at all times.

Keep these operating instructions in an accessible place and make them available to the personnel assigned.

1.2 Explanation of symbols



Triangular warning signs warn of danger.



Round command symbols tell what to do.

1.3 Qualified personnel

All work such as installation, commissioning, operation and service of the product may only be carried out by qualified personnel.

The personnel must have the necessary qualifications for the corresponding activity and be familiar with the installation, commissioning, operation and service of the product. The manual and in particular the safety instructions must be carefully read, understood and observed.

1.4 Liability

NTI AG (as manufacturer of LinMot and MagSpring products) excludes all liability for damages and expenses caused by incorrect use of the products. This also applies to false applications, which are caused by NTI AG's own data and notes, for example in the course of sales, support or application activities. It is the responsibility of the user to check the data and information provided by NTI AG for correct applicability in terms of safety. In addition, the entire responsibility for safety-related product functionality lies exclusively with the user. Product warranties are void if products are used with stators, sliders, servo drives or cables not manufactured by NTI AG unless such use was specifically approved by NTI AG.

NTI AG's warranty is limited to repair or replacement as stated in our standard warranty policy as described in our "terms and conditions" previously supplied to the purchaser of our equipment (please request copy of same if not otherwise available). Further reference is made to our general terms and conditions.

1.5 Copyright

This work is protected by copyright.

Under the copyright laws, this publication may not be reproduced or transmitted in any form, electronic or mechanical, including photocopying, recording, microfilm, storing in an information retrieval system, not even for training purposes, or translating, in whole or in part, without the prior written consent of NTI AG.

LinMot® is a registered trademark of NTI AG.

2 Safety instructions

2.1 Appropriate application

The linear motors of the types described here are used exclusively to carry out linear movements. The direct drives are intended for use in industrial plants. The motors are only operated with original LinMot servo drives. For external temperature monitoring, 2 temperature sensors and a temperature relay are used, which interrupts the power supply in the event of a fault. The motors are intended for use in potentially explosive atmospheres which occasionally occur (zone classification 1, 21, 2, 22 according to DIN EN 60079-14). Explosivity can consist of gases, vapours, mists and dust. The motors are dimensioned for an ambient temperature of 0 °C to 60 °C. The motors are designed for a temperature range of 0 °C to 50 °C. The user determines the operating conditions and thus the maximum surface temperature of the device by means of the specific type of application of the motors. This allows several temperature classes to be assigned. The ATEX motors used here correspond to temperature class T4 (max. surface temperature = 135 °C) and T6 (max. surface temperature = 85 °C) according to DIN EN 60079-14. According to this, the devices may be used in an explosive atmosphere in which the ignition temperature is above the max. surface temperature.

2.2 Warning signs



Contusions

Sliders contain neodymium magnets and have a strong attractive force. Careless handling could cause fingers or skin to become pinched between two sliders. This may lead to contusions, bruises, and bone fractures. When handling sliders, wear thick protective gloves and keep a minimum distance between sliders. Refer to the "Minimum distance from slider" section for minimum distance.

To reduce the risk of injury, never more than one slider should be held or transported by the same person without packaging.



Pacemaker / Implanted heart defibrillator

Sliders could affect the functioning of pacemakers and implanted heart defibrillators. For the duration of a strong approach to a magnetic field, these devices switch into test mode and will not function properly.

- If you wear one of those devices keep the following minimum distances between the pacemaker / defibrillator and slider:
 - Min. 250 mm (10") for slider Ø 27 mm and 28 mm (PL01-27 / 28 / PL10-28)
 - Min. 150 mm (6") for slider Ø 19 mm and 20 mm (PL01-19 / 20)
 - Min. 100 mm (4") for slider Ø 12 mm (PL01-12)
- Inform others who wear these devices to comply with these minimum distances!



Caution - Risk of Electric Shock !

Before working, make sure that there are no high voltages.



Fast-moving machine parts

The sliders of LinMot linear motors are fast-moving machine parts. All necessary precautions must be taken to prevent persons approaching the moving elements during operation (provide covers, guards, etc.).



Automatic restart

The motors can start automatically under certain circumstances! If necessary, a corresponding warning symbol must be provided and protection against entering the hazardous area or a suitable safe electronic disconnection must be provided!



Risk of injury due to a defect or fault

For areas where a defect or fault can result in substantial property damage or even serious personal injury, additional external precautions must be taken or devices must be installed to ensure safe operation even if a defect or fault occurs (eg. suitable safe electronic disconnection, mechanical interlocks, barriers, etc.).



Magnetic field

Magnets integrated in the sliders produce a strong magnetic field. They could damage TVs, laptops, computer hard drives, credit and ATM cards, data storage media, mechanical watches, hearing aids, and speakers.

- Keep magnets away from devices and objects that could be damaged by strong magnetic fields.
- For the above mentioned objects, keep a minimum distance as described in the "Pacemaker / implanted defibrillator" section.
- For non-anti-magnetic watches, keep the double minimum distance.

**Combustibility**

When machining magnets, the drilling dust could easily ignite. Machining the sliders and the magnets they contain is not permitted.

**Burn hazard**

The sliders of LinMot motors can reach temperatures of 80 °C, which may cause burns upon contact.

**Grounding**

All metal parts that are exposed to contact during any user operation or servicing and likely to become energized shall be reliably connected to the means for grounding.

**Mechanical handling**

Neodymium magnets are brittle and heat-sensitive. Machining the sliders and the magnets they contain is not permitted.

- Colliding magnets could crack. Sharp splinters could be catapulted for several meters and cause eye injury.
- By machining the sliders, heat would result which demagnetises the magnets.

**Slider**

Linear motor sliders consist of a high-precision, thin-walled stainless steel tube in which the neodymium magnets are housed. The LinMot sliders should be handled with care. Avoid contact with other sliders or iron parts as this can damage the magnets and the slider surface. Do not grip the sliders with pliers, as this can also damage the surface. Do not use sliders which are already damaged on the surface (scratches, deformation, etc.). This can cause further damage to the stator.

**Effects on people**

According to the current level of knowledge, magnetic fields of permanent magnets do not have a measurable positive or negative effect on people. It is unlikely that permanent magnets constitute a health risk, but it cannot be ruled out entirely.

- For your own safety, avoid constant contact with magnets.
- Store large magnets at least one meter away from your body.

**Temperature resistance**

Keep slider away from unshielded flame or heat. Temperature above 150°C will cause demagnetization.

2.3 Additional ATEX safety instructions



Assembly, commissioning, and maintenance of the motors may be performed only by qualified personnel who are familiar with the directives of DIN EN 60079-14.



Maintenance and service work may be performed only in a clean room with no explosive atmosphere. Dangerous ignition sources may arise when disassembling component parts.



Only original parts from LinMot may be used for commissioning and maintenance work.



The stator is grounded via the motor cable. The connector must be firmly tightened. Observe the specified tightening torque in chapter 3.9.



Do not separate when energized.



Operation is allowed only in conjunction with a temperature relay and circuit breaker.



Only for use with a LinMot inverter.



The permissible ambient temperature for operating the motor is 0 °C ... +60°C.

3 Product description

3.1 Structure

LinMot ATEX linear motors are assembled into a complete servo drive system consisting of several connected components (see the illustration below). Only the motor is located in the "hazardous" area, all other components are located on the "safe" side.

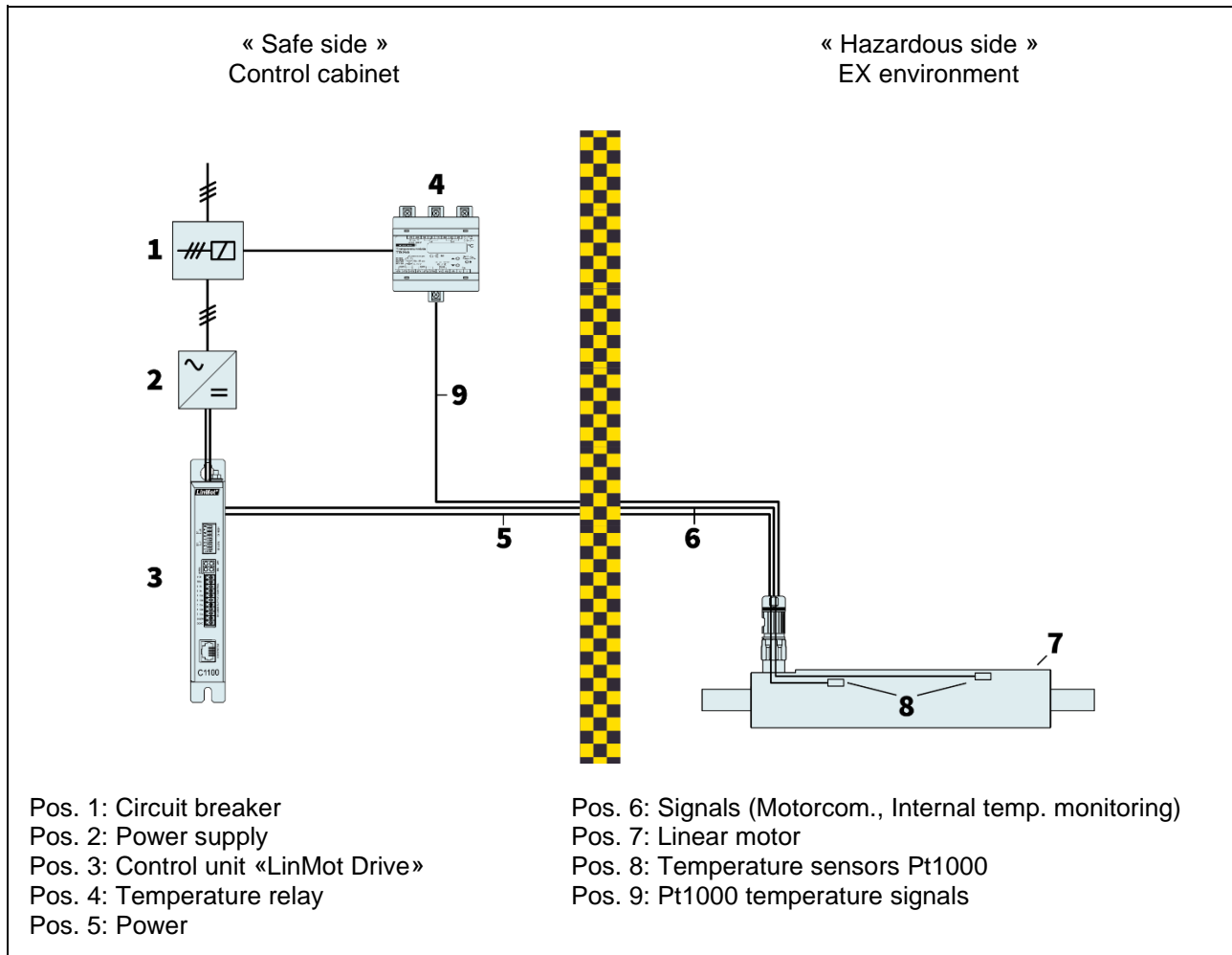

3.1.1 Linear Motor

LinMot motors are direct-drive electromagnetic tubular linear motors. The main components of the motor are the stator and the slider. The slider, the so-called "magnet bar", consists of permanent magnets that are arranged with alternating polarization. The stator contains the windings and position sensors. The windings are fed with current at an appropriate electrical phase angle, like a permanently excited synchronous motor, thus producing a force in the desired direction. The motor has 2 to 4 temperature sensors on the windings depending on the length. These sensors can be used with a series x1100 or x1200 LinMot drive to read and analyze the absolute temperature. This allows the winding temperature to be determined and the motor to be switched off if the motor runs too hot. If the drive can no longer communicate with the motor, then it will shift to a fault state. Feedback is provided to the control system. The position is sensed by measuring the magnetic field of the slider. The stator is encapsulated and welded completely shut. ATEX linear motors can be equipped with a copper cooling system as an option.

3.1.2 LinMot Servo Drive

Takes over the current control, positioning control and temperature monitoring of the motor as well as monitoring the power section.

3.1.3 Temperature relay

Receives values from the Pt1000 temperature sensors mounted on the exterior of the motor under the stainless steel housing. In case of a fault (overtemperature), it initiates the interruption of the power supply to the servo drive. Feedback to the machine control system.

3.1.4 Circuit breaker

Interrupts the system power supply if the maximum surface temperature setting is exceeded.

3.2 Exterior view

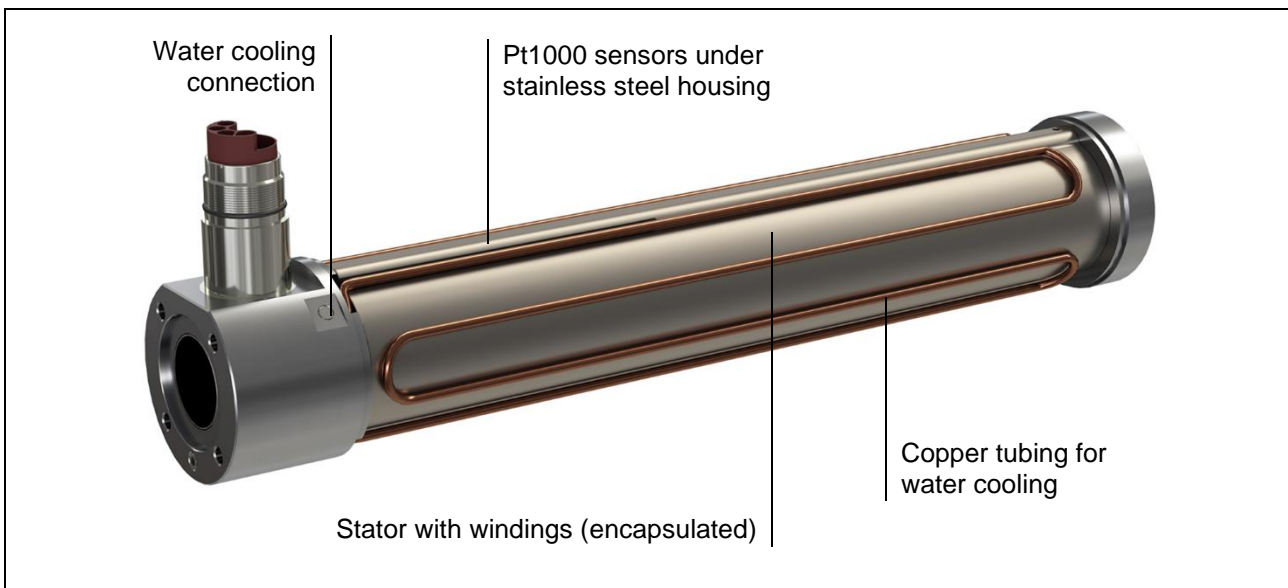
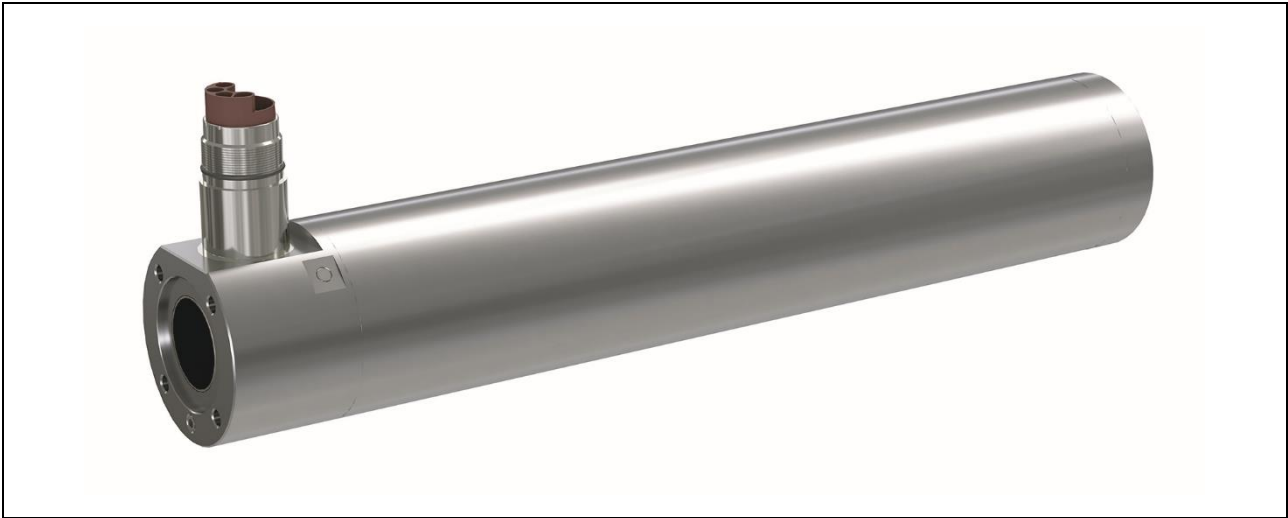

3.3 Interior view

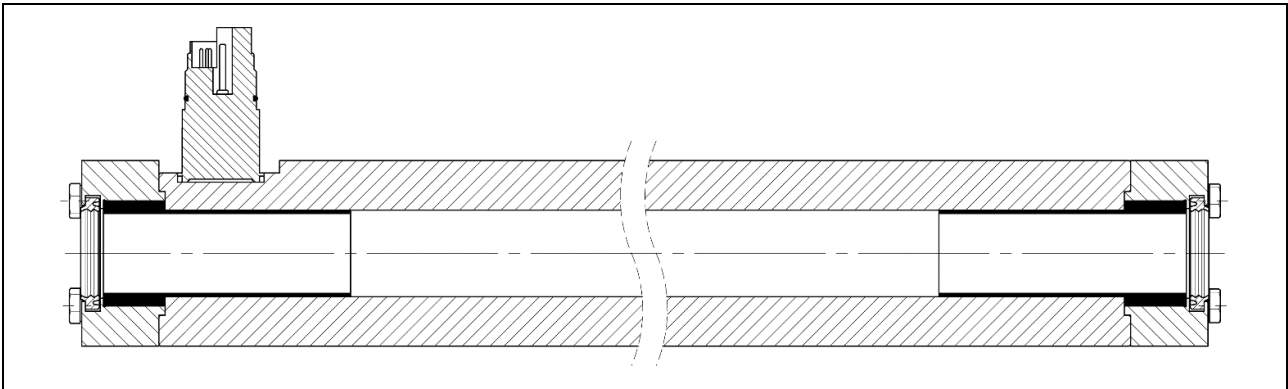

3.4 Technical data

		PS01-48x150G-HP-EX-E (Art: 0150-4370) PS01-48x150G-HP-EX-E-FC (Art: 0150-4371)								
Stroke	mm (in)	80 (3.15)	170 (6.69)	290 (11.42)	380 (14.96)	470 (18.49)	590 (23.23)	680 (26.75)	890 * (35.04)	1070 * (42.13)
Maximum force E12x0-UC	N (lbf)	310 (69.70)								
Maximum force E11x0-XC	N (lbf)	310 (69.70)								
Nominal force	N (lbf)	65 (14.60)								
Nom. force, liquid cooled	N (lbf)	175 (39.35)								
Force constant	N/A (lbf/A)	21.9 (5.14)								
Max. Current @ 72VDC	A	14.1								
Max. Speed @ 72VDC	m/s (in/s)	3.0 (118)								
Phase resist. 25/120 °C	Ohm	0.87 / 1.2								
Phase inductivity	mH	0.7								
Stator diameter	mm (in)	60 (2.36)								
Stator length	mm (in)	255 (10.04)								
Stator mass	g (lb)	2742 (6.05)								
Slider diameter	mm (in)	27 (0.059)								
Slider length	mm (in)	410 (16.14)	500 (19.69)	620 (24.41)	710 (27.95)	800 (31.50)	920 (36.22)	1010 (39.76)	1220 (48.03)	1400 (55.12)
Slider mass	g (lb)	1620 (3.57)	2010 (4.43)	2530 (5.58)	2920 (6.44)	3310 (7.30)	3830 (8.44)	4220 (9.30)	5130 (11.31)	5910 (13.03)
Repeatability	mm (in)	±0.05 (±0.0020)								
Linearity	%	±0.10								
Repeatability with EPS	mm (in)	±0.01 (±0.0004)								
Linearity with EPS	mm (in)	±0.01 (±0.0004)								

* on request

Ordering information

Item	Description	Item-No.
PS01-48x150G-HP-EX-E	Stator HP, EX, IP67	0150-4370
PS01-48x150G-HP-EX-E-FC	Stator HP, EX, IP67, FC	0150-4371

Item	Description	Slider length mm (in)	Item-No.
PL01-27x410/330	Slider 'high clearance'	410 (16.14)	0150-1468
PL01-27x500/420	Slider 'high clearance'	500 (19.69)	0150-1469
PL01-27x620/540	Slider 'high clearance'	620 (24.41)	0150-1470
PL01-27x710/630	Slider 'high clearance'	710 (27.95)	0150-1471
PL01-27x800/720	Slider 'high clearance'	800 (31.50)	0150-1472
PL01-27x920/840	Slider 'high clearance'	920 (36.22)	0150-1447
PL01-27x1010/930	Slider 'high clearance'	1010 (39.76)	0150-1473
PL01-27x1220/1140	Slider 'high clearance'	1220 (48.03)	0150-1587
PL01-27x1400/1320	Slider 'high clearance'	1400 (55.12)	0150-1588

Item	Description	Item-No.
PB01-48x25-80-F-SSC	Bearing for PS01-48x...-SSC (Stainless/ATEX)	0150-6339
PB03-48x25-80-F-SSC	Bearing for PS01-48x...-SSC (Stainless/ATEX)	0150-6340

		PS01-48x240F-HP-EX-E (Art: 0150-4365) PS01-48x240F-HP-EX-E-FC (Art: 0150-4366)							
Stroke	mm (in)	80 (3.15)	200 (7.87)	290 (11.42)	380 (14.96)	500 (19.69)	590 (23.23)	800 (31.50)	980 (38.58)
Maximum force E12x0-UC	N (lbf)	496 (111.51)							
Maximum force E11x0-XC	N (lbf)	477 (107.23)							
Nominal force	N (lbf)	98 (22.03)							
Nom. force, liquid cooled	N (lbf)	280 (62.95)							
Force constant	N/A (lbf/A)	19.1 (4.29)							
Max. Current @ 72VDC	A	25.9							
Max. Speed @ 72VDC	m/s (in/s)	3.4 (134)							
Phase resist. 25/120 °C	Ohm	0.97 / 1.3							
Phase inductivity	mH	1.1							
Stator diameter	mm (in)	60 (2.36)							
Stator length	mm (in)	345 (13.58)							
Stator mass	g (lb)	3710 (8.18)							
Slider diameter	mm (in)	27 (0.059)							
Slider length	mm (in)	500 (19.69)	620 (24.41)	710 (27.95)	800 (31.50)	920 (36.22)	1010 (39.76)	1220 (48.03)	1400 (55.12)
Slider mass	g (lb)	2010 (4.43)	2530 (5.58)	2920 (6.44)	3310 (7.30)	3830 (8.44)	4220 (9.30)	5130 (11.31)	5910 (13.03)
Repeatability	mm (in)	±0.05 (±0.0020)							
Linearity	%	±0.10							
Repeatability with EPS	mm (in)	±0.01 (±0.0004)							
Linearity with EPS	mm (in)	±0.01 (±0.0004)							

Ordering information

Item	Description	Item-No.
PS01-48x240F-HP-EX-E	Stator HP, EX, IP67	0150-4365
PS01-48x240F-HP-EX-E-FC	Stator HP, EX, IP67, FC	0150-4366

Item	Description	Slider length mm (in)	Item-No.
PL01-27x500/420	Slider 'high clearance'	500 (19.69)	0150-1469
PL01-27x620/540	Slider 'high clearance'	620 (24.41)	0150-1470
PL01-27x710/630	Slider 'high clearance'	710 (27.95)	0150-1471
PL01-27x800/720	Slider 'high clearance'	800 (31.50)	0150-1472
PL01-27x920/840	Slider 'high clearance'	920 (36.22)	0150-1447
PL01-27x1010/930	Slider 'high clearance'	1010 (39.76)	0150-1473
PL01-27x1220/1140	Slider 'high clearance'	1220 (48.03)	0150-1587

PL01-27x1400/1320	Slider 'high clearance'	1400 (55.12)	0150-1588
-------------------	-------------------------	--------------	-----------

Item	Description	Item-No.
PB01-48x25-80-F-SSC	Bearing for PS01-48x...-SSC (Stainless/ATEX)	0150-6339
PB03-48x25-80-F-SSC	Bearing for PS01-48x...-SSC (Stainless/ATEX)	0150-6340

		PS01-48x360F-HP-EX-E (Art: 0150-4367) PS01-48x360F-HP-EX-E-FC (Art: 0150-4368)						
Stroke	mm (in)	80 (3.15)	170 (6.69)	260 (10.24)	380 (14.96)	470 (18.50)	680 (26.77)	860 (33.86)
Maximum force E12x0-UC	N (lbf)	721 (162.1)						
Maximum force E11x0-XC	N (lbf)	562 (126.3)						
Nominal force	N (lbf)	151 (34.9)						
Nom. force, liquid cooled	N (lbf)	408 (91.7)						
Force constant	N/A (lbf/A)	27.7 (6.23)						
Max. Current @ 72VDC	A	25.9						
Max. Speed @ 72VDC	m/s (in/s)	2.35						
Phase resistance 25/120 °C	Ohm	1.4 / 1.9						
Phase inductivity	mH	1.6						
Stator diameter	mm (in)	60 (2.36)						
Stator length	mm (in)	465 (18.31)						
Stator mass	g (lb)	5000 (11.02)						
Slider diameter	mm (in)	27 (0.059)						
Slider length	mm (in)	620 (24.41)	710 (27.95)	800 (31.50)	920 (36.22)	1010 (39.76)	1220 (48.03)	1400 (55.12)
Slider mass	g (lb)	2530 (5.58)	2920 (6.44)	3310 (7.30)	3830 (8.44)	4220 (9.30)	5130 (11.31)	5910 (13.03)
Repeatability	mm (in)	±0.05 (±0.0020)						
Linearity	%	±0.10						
Repeatability with EPS	mm (in)	±0.01 (±0.0004)						
Linearity with EPS	mm (in)	±0.01 (±0.0004)						

Ordering information

Item	Description	Item-No.
PS01-48x360F-HP-EX-E	Stator HP, EX, IP67	0150-4367
PS01-48x360F-HP-EX-E-FC	Stator HP, EX, IP67, FC	0150-4368

Item	Description	Slider length mm (in)	Item-No.
PL01-27x620/540	Slider 'high clearance'	620 (24.41)	0150-1470
PL01-27x710/630	Slider 'high clearance'	710 (27.95)	0150-1471
PL01-27x800/720	Slider 'high clearance'	800 (31.50)	0150-1472
PL01-27x920/840	Slider 'high clearance'	920 (36.22)	0150-1447
PL01-27x1010/930	Slider 'high clearance'	1010 (39.76)	0150-1473
PL01-27x1220/1140	Slider 'high clearance'	1220 (48.03)	0150-1587
PL01-27x1400/1320	Slider 'high clearance'	1400 (55.12)	0150-1588

Artikel	Beschreibung	Art-Nr.
PB01-48x25-80-F-SSC	Bearing for PS01-48x...-SSC (Stainless/ATEX)	0150-6339
PB03-48x25-80-F-SSC	Bearing for PS01-48x...-SSC (Stainless/ATEX)	0150-6340

3.5 Performance characteristic

With the design software "LinMot Designer" software (download from the link <https://linmot.com/download/linmot-designer/>), the key data corresponding to the required load situation, such as peak force, nominal force, or maximum speed, can be calculated and presented. The motor operating temperature can also be determined. This must be verified in the real application.

3.6 Thermal behavior

3.6.1 Internal temperature monitoring

Setting the motor internal temperature monitoring:

Operation in temperature class T4

The temperature monitoring configuration can be left in the default settings.

The nominal sensor operating temperature is 90°C. At 95 °C a warning is given and at 100 °C the drive goes into error state. The LinMot-Designer program provides concrete information on the motion designs.



Logging in is necessary to view these parameters.

- User-ID: «SERVICE»
- Password: without (in default state)

The screenshot shows the 'LinMot-Talk 6.8' software interface. The left sidebar displays a tree view of the configuration, with 'Monitoring' > 'Temperatur Monitoring' > 'Temperature Sensor' selected. The main window shows a table of parameters for the 'Temperature Sensor'.

Name	Value	Raw Data	Value...	UPID	Type	Scale
Temperature Sensor Type	Communication	0001h	***	1230h	UInt16	
Temp Sens 'Warn Time	0.5 s	01F4h	*** s	11F9h	UInt16	0.001 s
Temp Sens Error Time	1.5 s	05DCh	*** s	11FAh	UInt16	0.001 s
Temp Sens 'Warn Temp	95 °C	03B6h	*** °C	1251h	SInt16	0.1 °C
Temp Sens Error Temp	100 °C	03E8h	*** °C	1252h	SInt16	0.1 °C

T4 Max. Sensor Temperature (Default Setting)

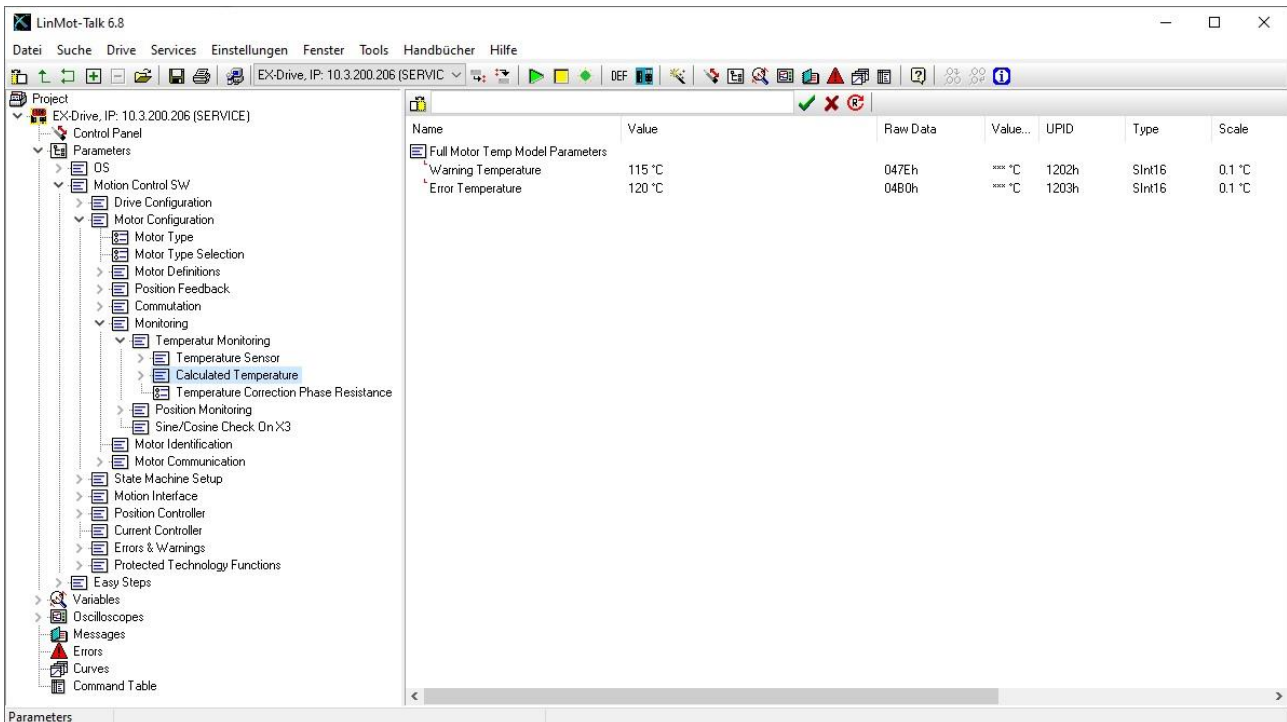

T4 Max. Winding Temperature (Default Setting)

Operation in temperature class T6



The sensor operating temperature is 60°C.
The parameters for temperature monitoring must be adjusted according to the following figures.

Logging in is necessary to view these parameters.

- User-ID: «SERVICE»
- Password: without (in default state)

A service password must be set to prevent unintentional changes.

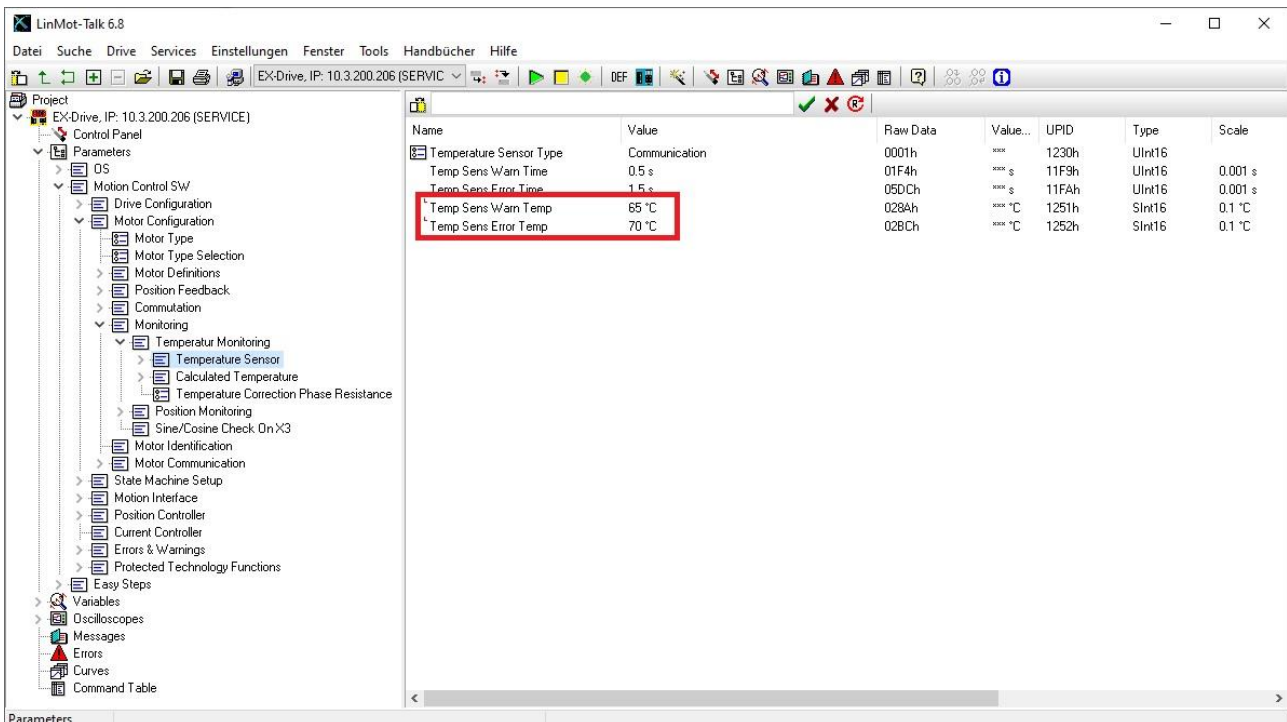

T6 Setting Max. Sensor Temperature

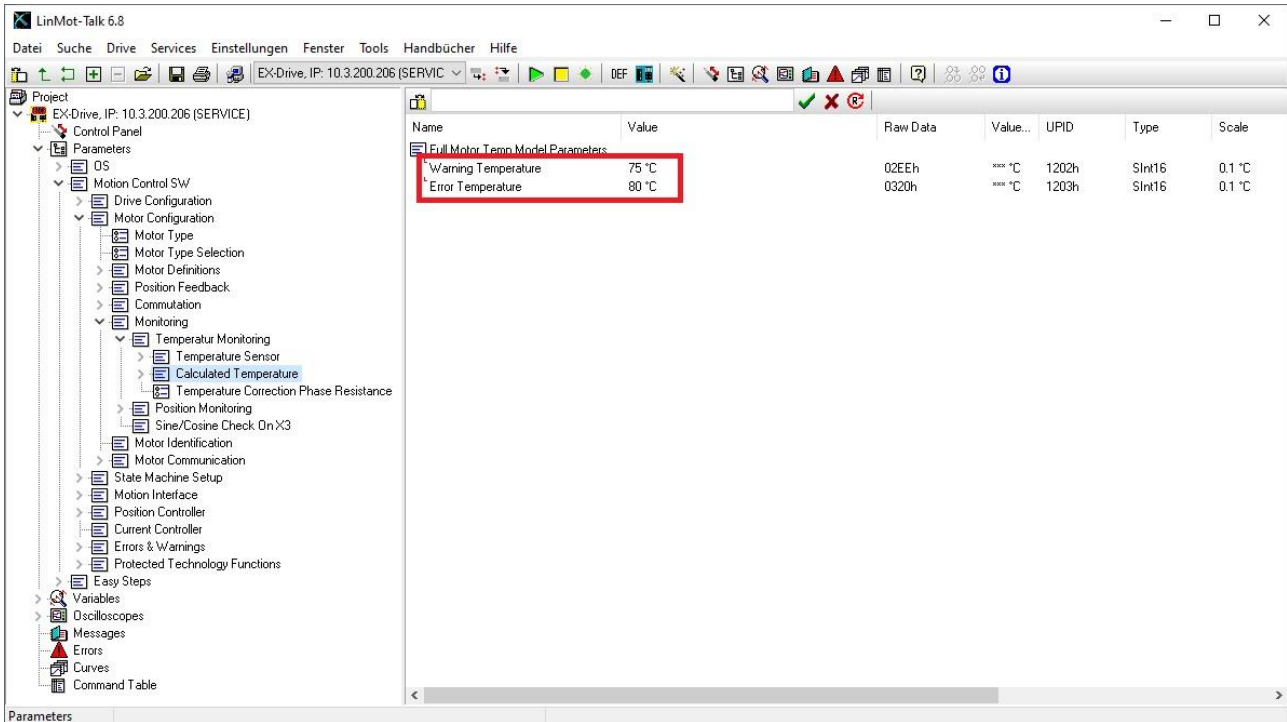

T6 Setting Max. Winding Temperature

3.6.2 Higher-level temperature monitoring

The motors have an additional superior temperature monitoring by means of 2 Pt1000 temperature sensors, which interrupts the power supply when the defined max. surface temperature is exceeded. The table below must be consulted for setting the temperature relay.

Setting of Temperature Relais

Temperature class	Sensor	Max. surface temperature
T4	Pt1000	135 °C
T6	Pt1000	85 °C

3.7 Dimensions

3.7.1 PS01-48x150 with bearing PB01

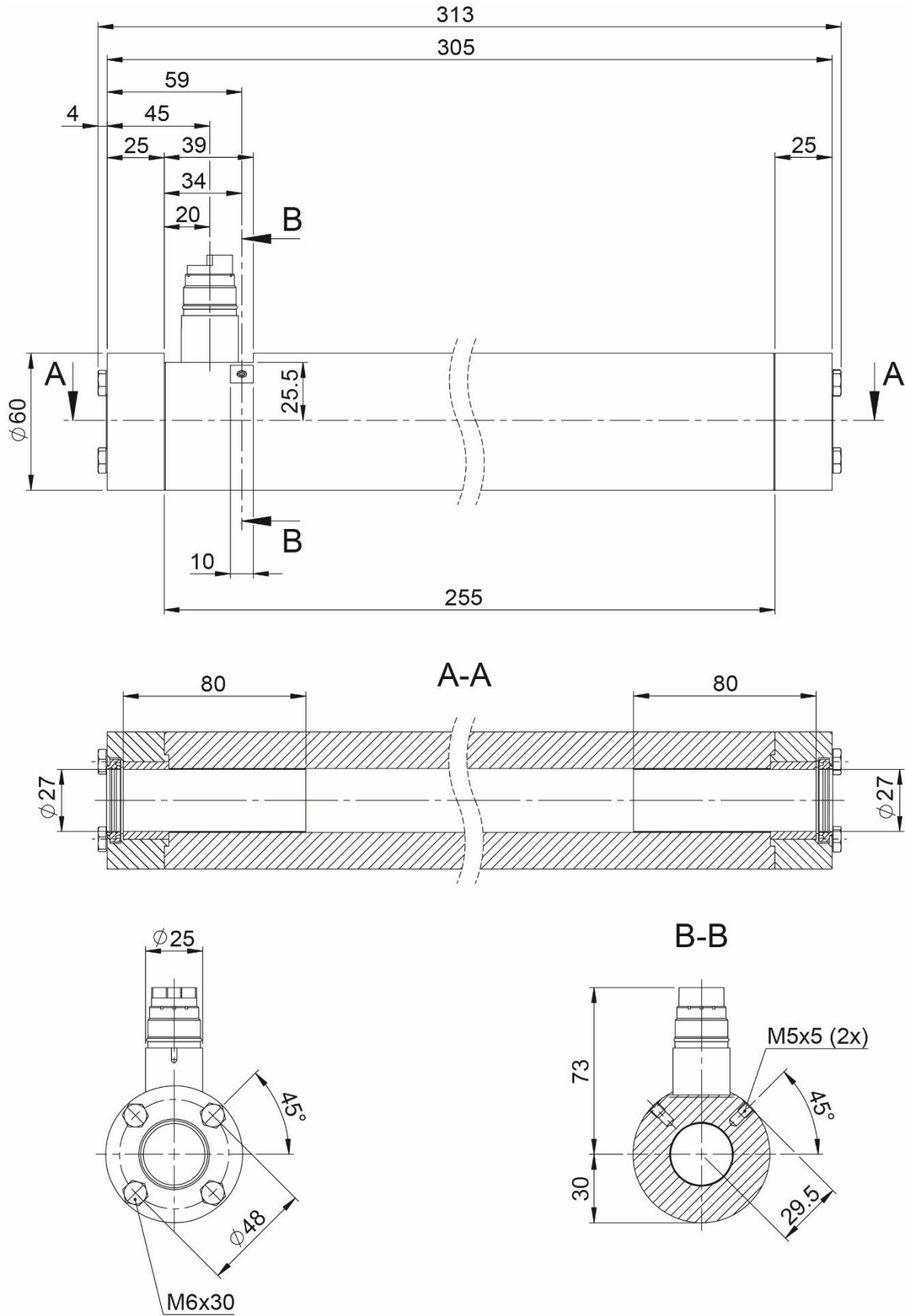

in mm

3.7.2 PS01-48x150 with bearing flange PB03

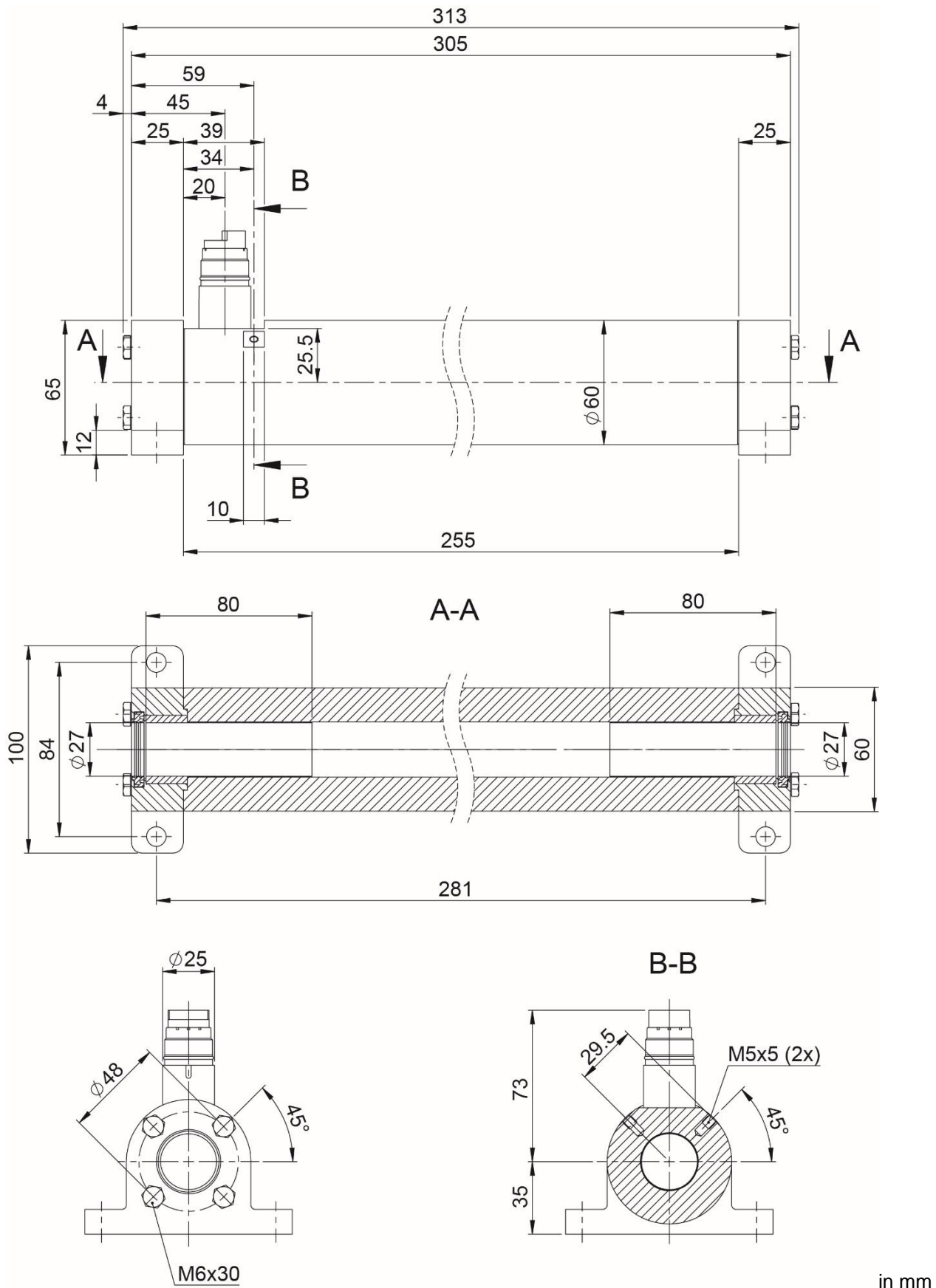

in mm

3.7.3 PS01-48x240 with bearing PB01

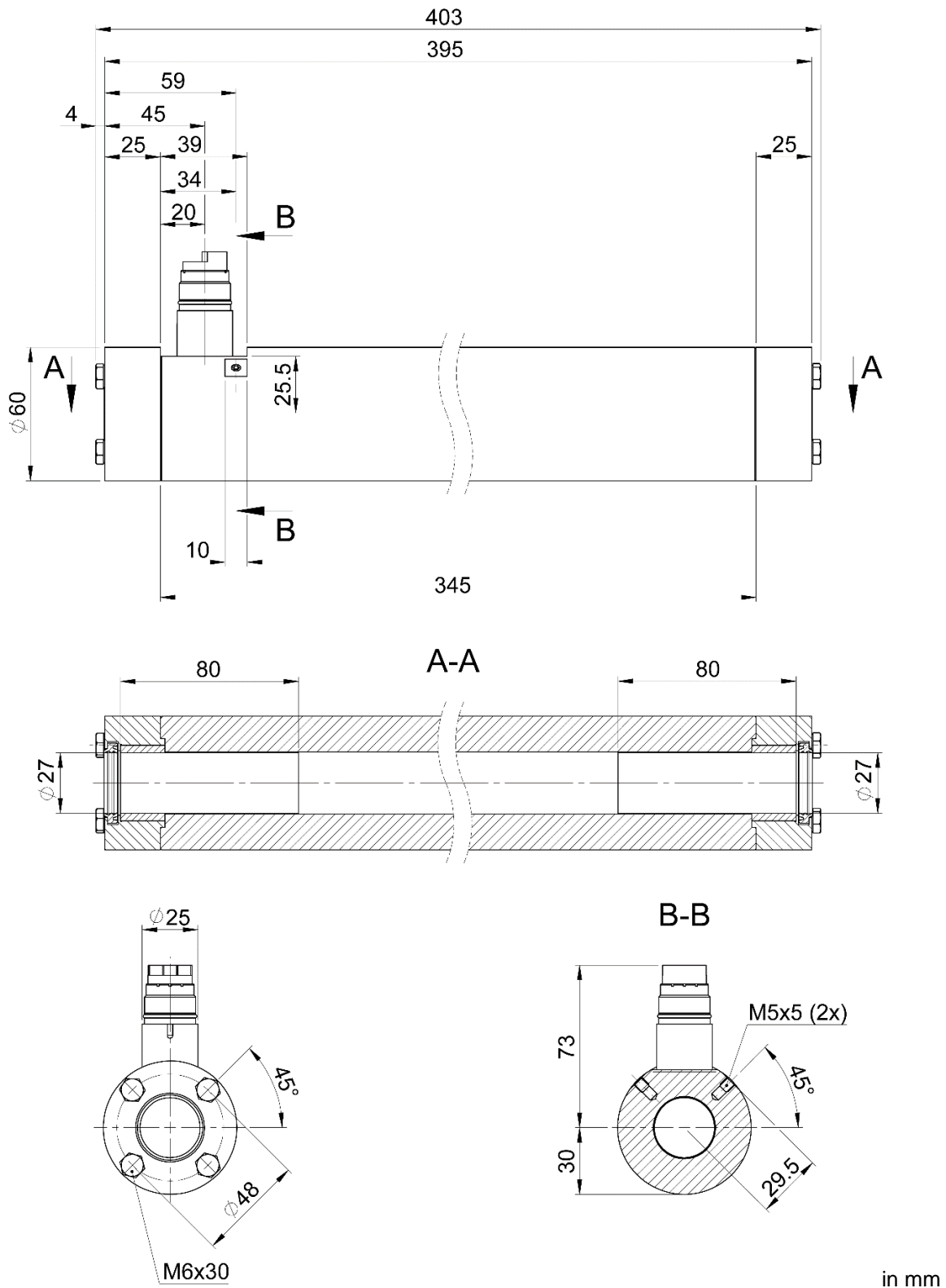

3.7.4 PS01-48x240 with bearing flange PB03

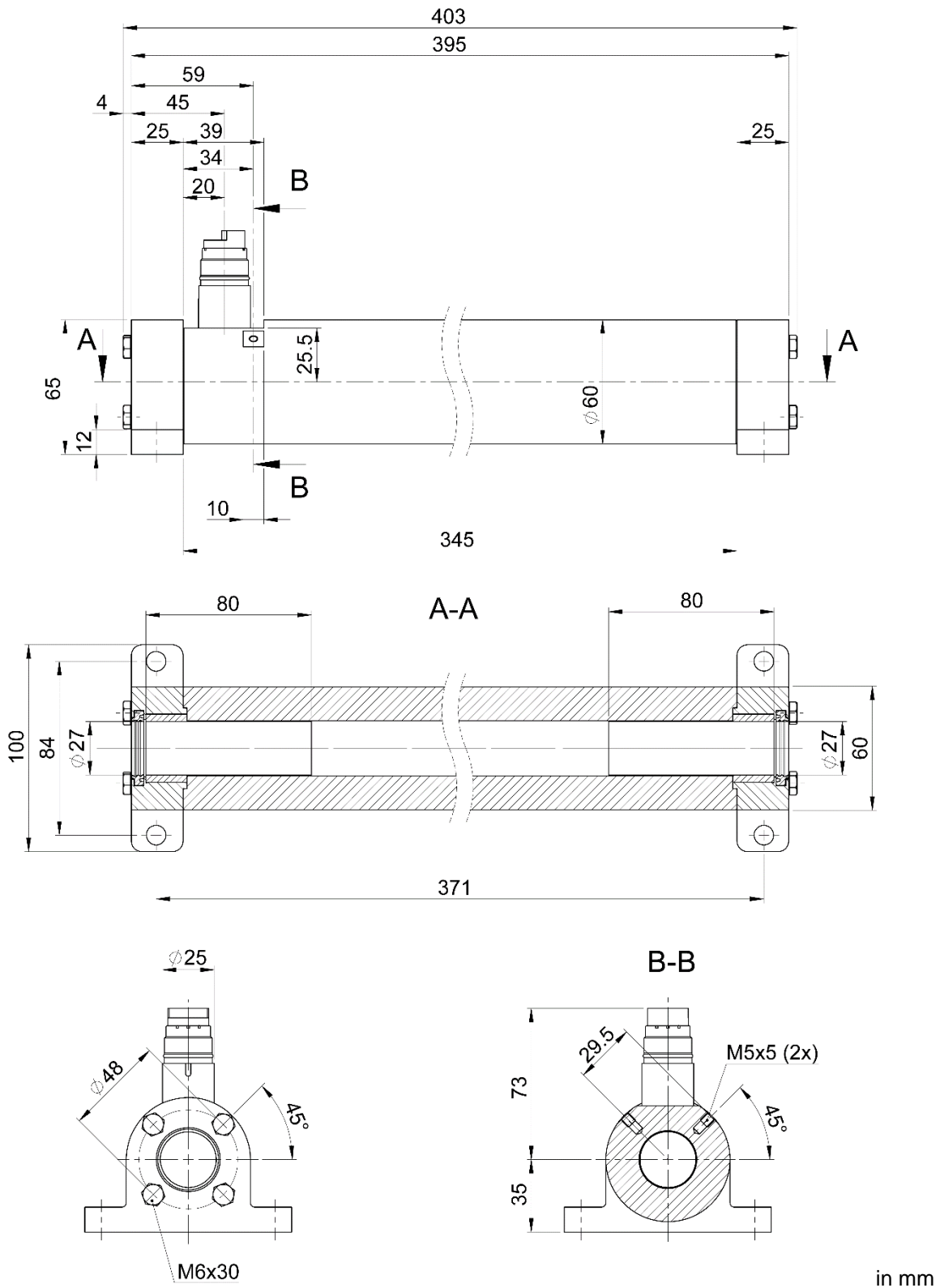

3.7.5 PS01-48x360 with bearing PB01

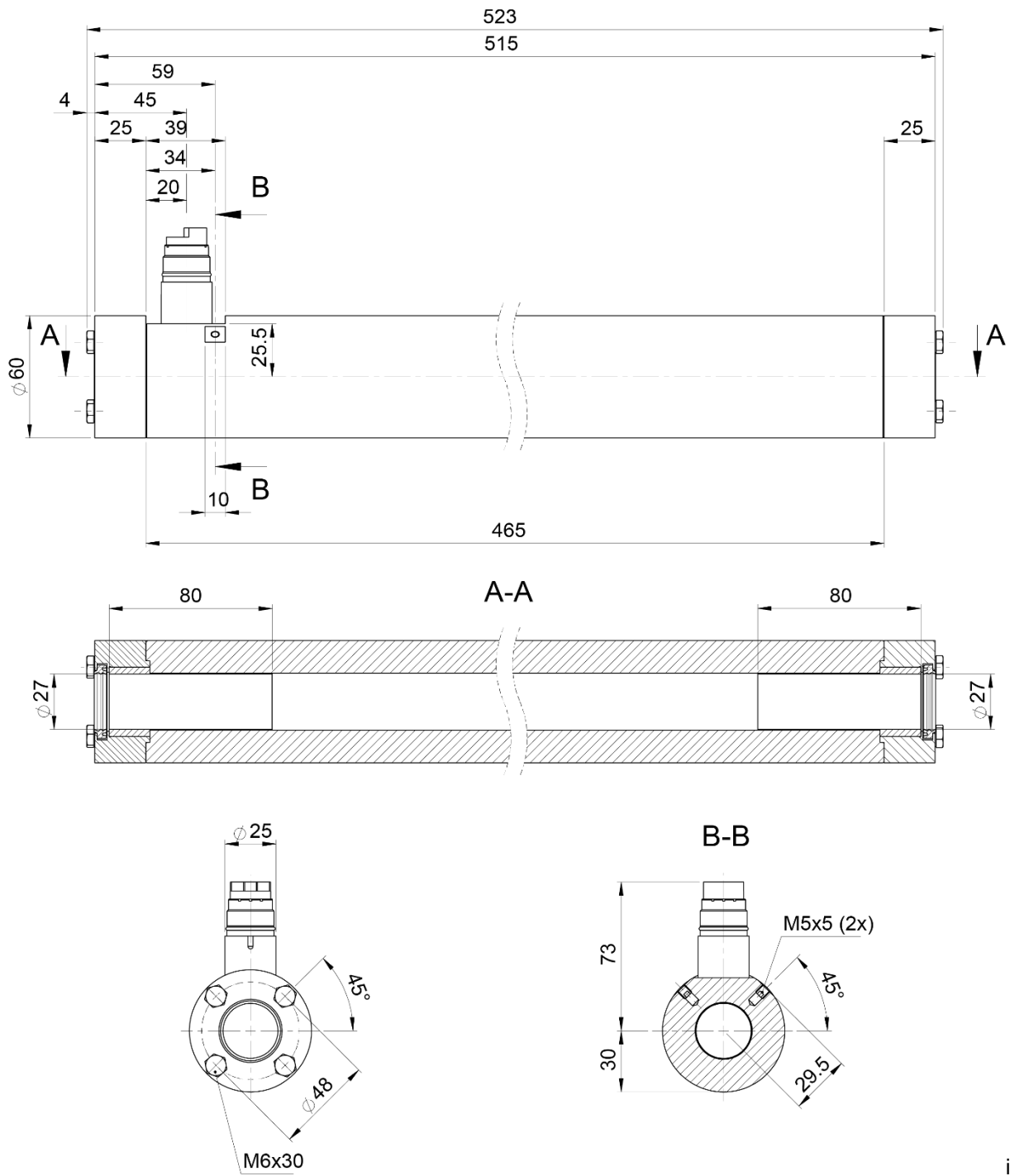

in mm

3.7.6 PS01-48x360 with bearing flange PB03

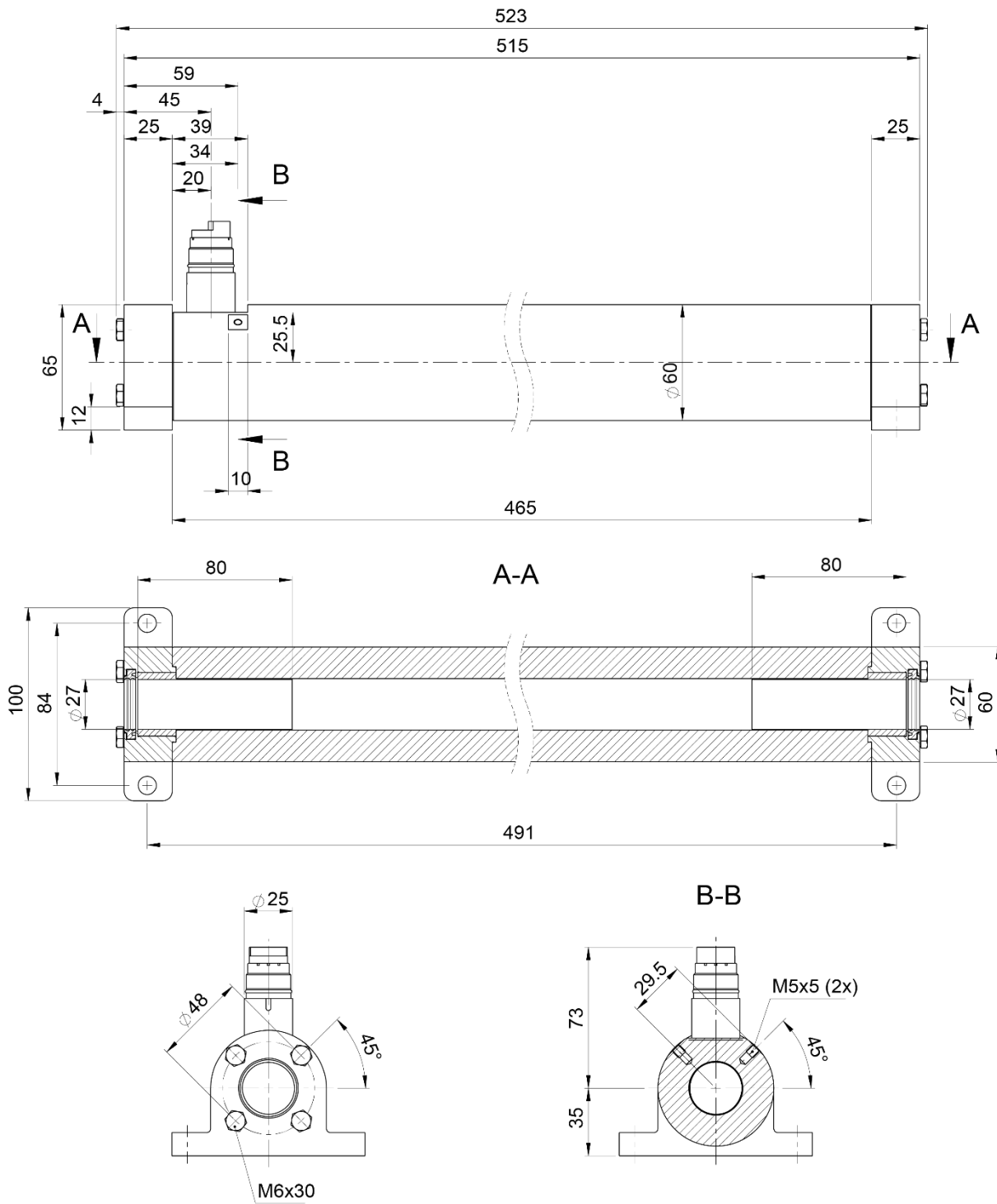

in mm

3.8 Marking

LinMot ATEX linear motors are identified as follows:

CE 1258 Ex II 2G Ex eb IIC T6...T4 Gb

CE 1258 Ex II 2D Ex tb IIIC T85 °C...T135 °C Db



Example of marking for item no. 0150-4365

3.9 Connector assignment

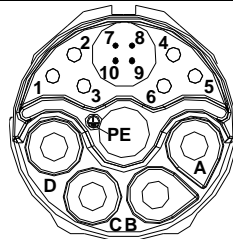

View: Motor connector, Plug side

Wiring	Pin	Wire color
Ph1+	A	Red
Ph1-	B	Pink
Ph2+	C	Blue
Ph2-	D	Grey
PE	PE	Green-Yellow
+5V	1	White
Gnd	2	Inner shield
Sin	3	Yellow
Cos	4	Green
Temp	5	Black
n.c.	6	-
Pt1000 1+	7	Orange
Pt1000 1-	8	Brown
Pt1000 2+	9	Purple
Pt1000 2-	10	Beige

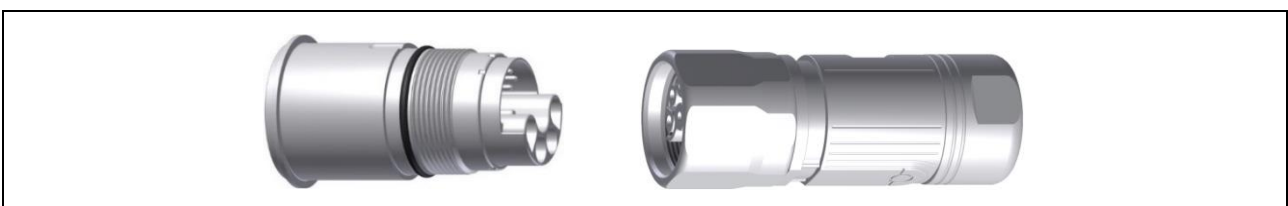

For the purpose of complete encapsulation, the plug is welded to the motor housing. The connector on the motor is made of stainless steel and has a thread for tightening. When plugged in, the protection class IP67 is fulfilled. The motor and cable connectors are screwed tightly together (tightening torque 5 Nm, WAF 27).

3.10 Motor cable

	KS10-05/05/04-EX
Cable type	High-Flex Cable
Minimum bending radius for fixed installation	60 mm (2.36 in)
Minimum bending radius when moving	120 mm (4.72 in)
Approval	UL / CSA 300V
Material wire isolation	TPE
Material cable sheath	PUR
Oil resistance	very good
Chemical resistance (to acids, alkalis, solvents, hydraulic fluid)	good
Outdoor durability	very good
Flammability	flame-retardant

Ordering information

Item	Description	Item-No.
KS10-EX-Y-Fe/E6k-	Trailing Chain Cable KS10-EX-Y-Fe/E6k-, Custom length	0150-3642

Item	Description	Item-No.
MC01-Y-Fe/m	Motor Connector Y-Fe/m	0150-3289
MC01-E6k/f-EX	Connerctor with hexagonal union nut	0150-3538
KS10-05/05/04-EX	Motor cable for EX applications per m	0150-9010

3.11 Cabling

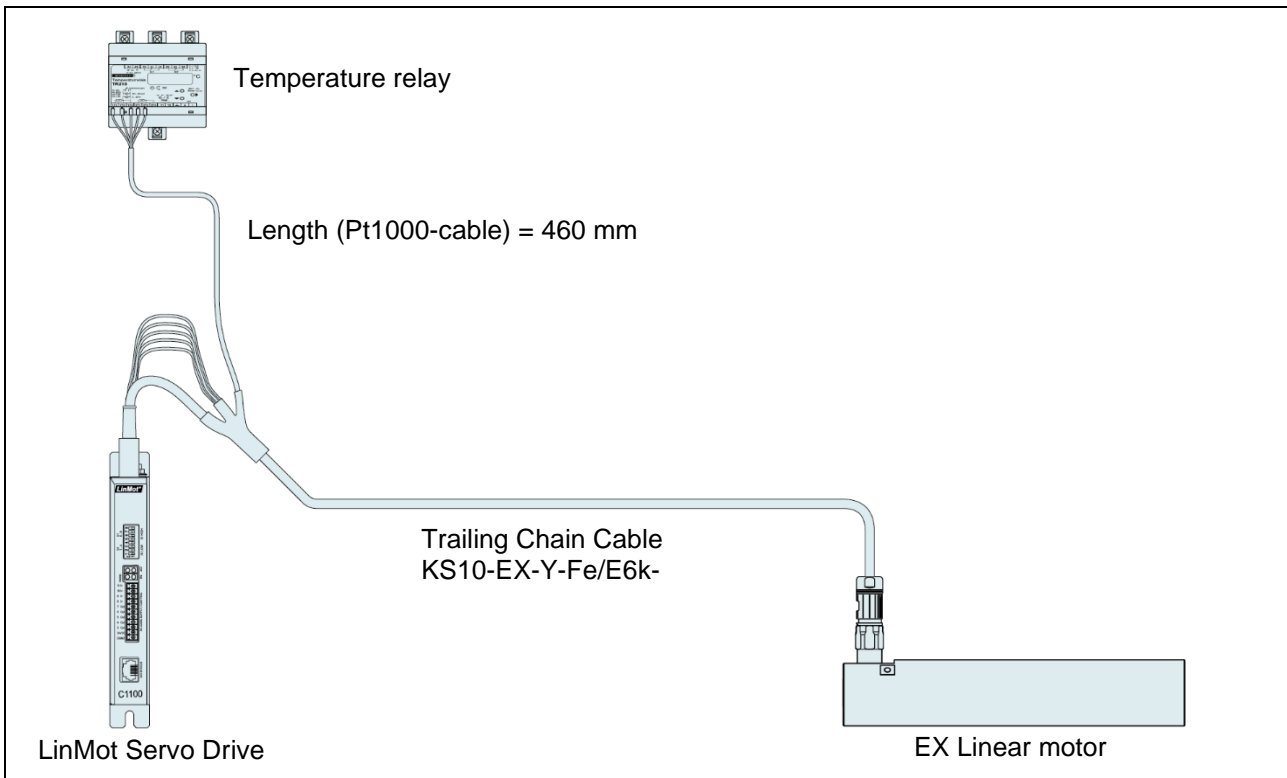

The cables must be laid in such a way that they cannot be damaged by external influences.

4 Installation and commissioning



- The specified power supply to the drive unit must not be exceeded.
- All intended operating modes of the linear motors must be designed in accordance with the design software and verified in application testing.
- In order to avoid unintended use, the information on the rating plate must be complied with.
- Installation must be carried out in accordance with the IEC/EN 60079-14 standard.

4.1 Operating conditions



- Maximum ambient temperature limits are 0 °C...60 °C
- The temperature of the cooling fluid must not fall below the ambient temperature, as this presents a risk of water condensation. See Paragraph 4.8, Liquid cooling.
- The maximum switch-off temperature to be set on the temperature relay is 85 °C or 135 °C, depending on the temperature class.
- The max. installation altitude is 2'000 m (for higher values contact LinMot) above sea level.
- From 1'000 m, derating of 1 °C per 100 m is to be considered for air cooling.

4.2 Mounting the motor



Please attend to the safety instructions in the chapter 2 during the assembling!

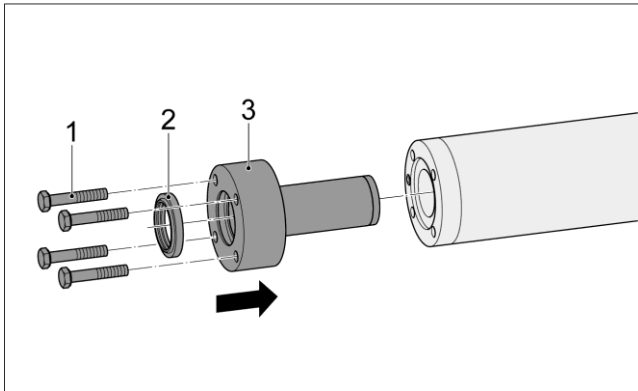

- 1. Installing the external bearing (front).**
Pos. 1: Hexagon head screw M6 x 35 (Torque = 6 Nm)
Pos. 2: Wiper
Pos. 3: Bearing (PB01) or Bearing flange (PB03)



Mount the bearing / bearing flange with care, since the plastic sleeve may break.

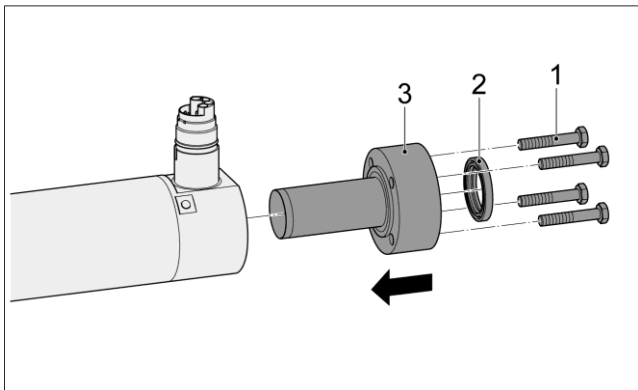

- 2. Installing the external bearing (rear).**



The corresponding bearings must be ordered separately! A selection can be found in section 3.4.

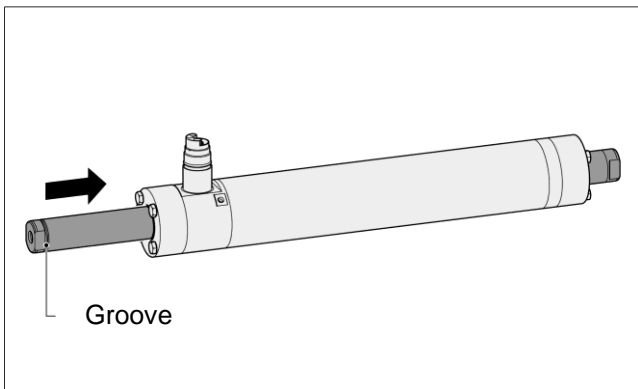

- 3. Insert the slider into the stator.**
After installation, the notch of the slider is located on the connector side.



The slider is magnetically attracted.

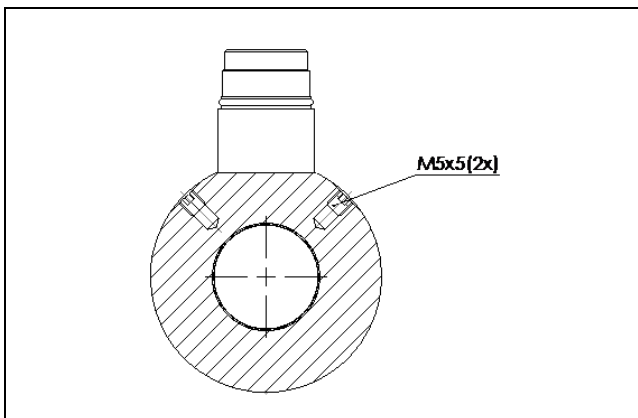

- 4. If fluid cooling is used, remove headless screws.**
For the stator variant with liquid cooling, the headless screws must be removed and replaced with the corresponding threaded plugs. See additional details in Paragraph 4.8.5

4.3 Mounting the flange

The motor is leveled and attached by means of the mounting threads at both ends of the stator. The hole pattern is shown on p. 15 in the Dimensions section.

4.4 Mounting the payload to the slider

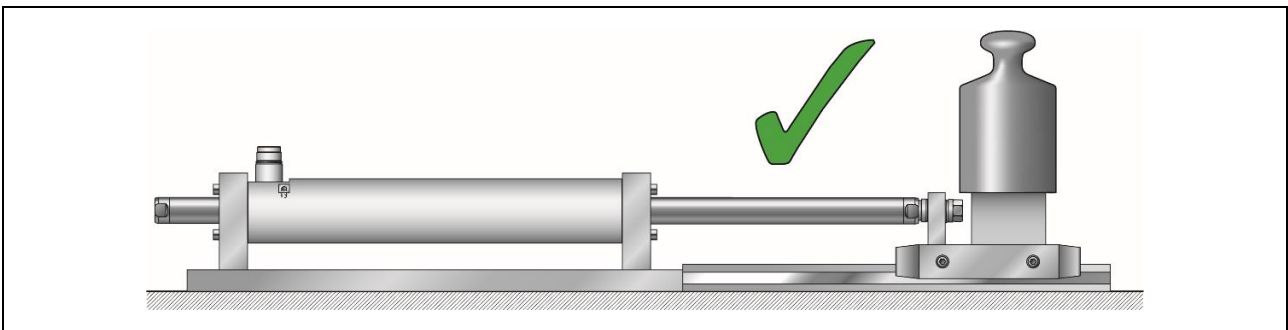
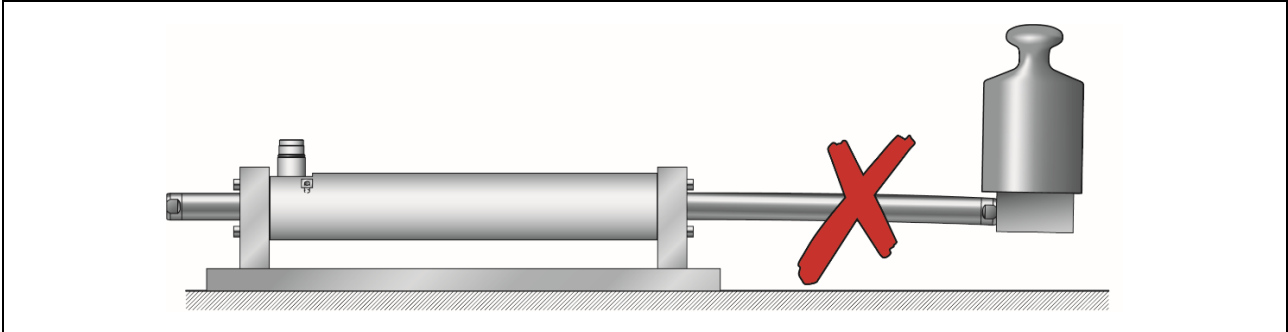

The load is mounted as a fixed bearing using spherical washers and conical seats (see the section on Slider accessories / mounting kits)

To avoid shear force on slider and wear on stator, the payload has to be supported by a linear guide.



When attaching the load, the wrench for tightening the load must be used only on the load-facing side of the slider. It is important to avoid torsional stress on slider (note figure below).

Slider	Thread	Max. torque for screw
27 mm	M 10	47 Nm

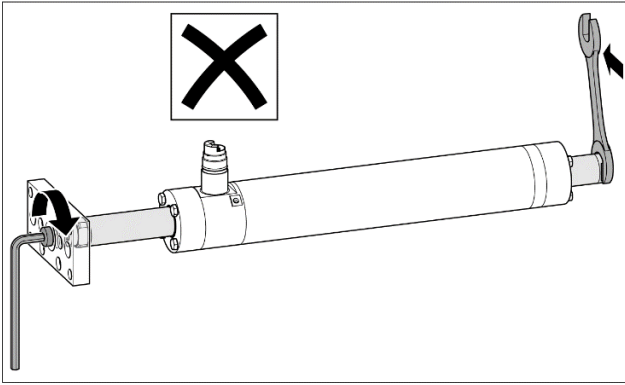

Incorrect assembly
Torsional stress on slider

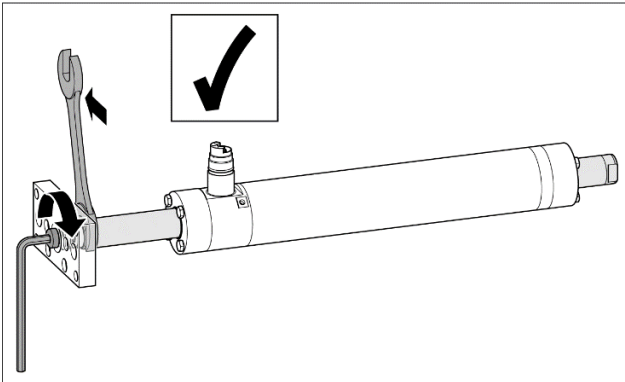

Correct assembly

4.5 «Moving slider» installation

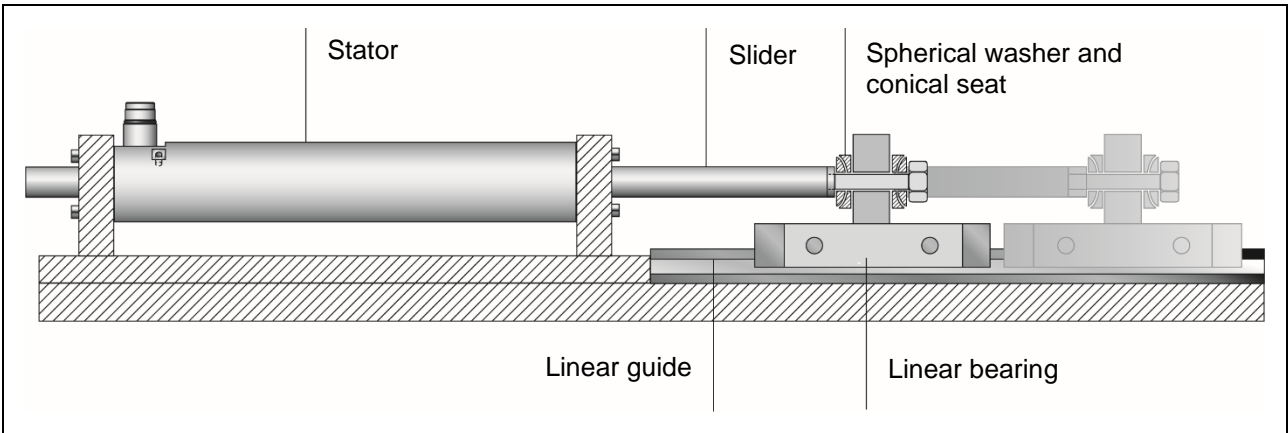

In a "moving slider" installation, the stator is fixed and the slider is the moving part. The load, borne by a linear guide, is attached directly to the end of the slider. In order to compensate for misalignment, spherical axial bearings consisting of spherical washers and conical seats (see the section 5.1 Slider mounting kit fixed bearing) are used to connect to the load. The mounting kit of slider and an oversized hole for the screw make it possible to adjust a radial and angle offset.

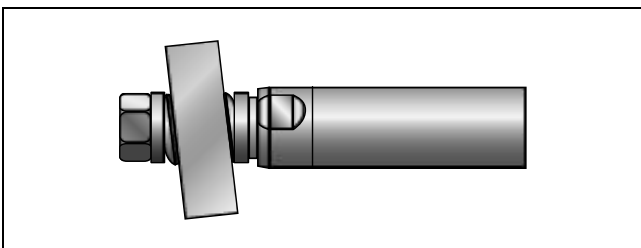

Mounted payload with radial and angle offset

4.6 Electrical connection of the motor



The connection must be made by a technician in accordance with applicable standards and safety regulations. The applicable installation and operating specifications and typical national and international specifications must be considered. Follow the information on the rating plate. For EX-products the installation standard EN/IEC 60079-14 applies.

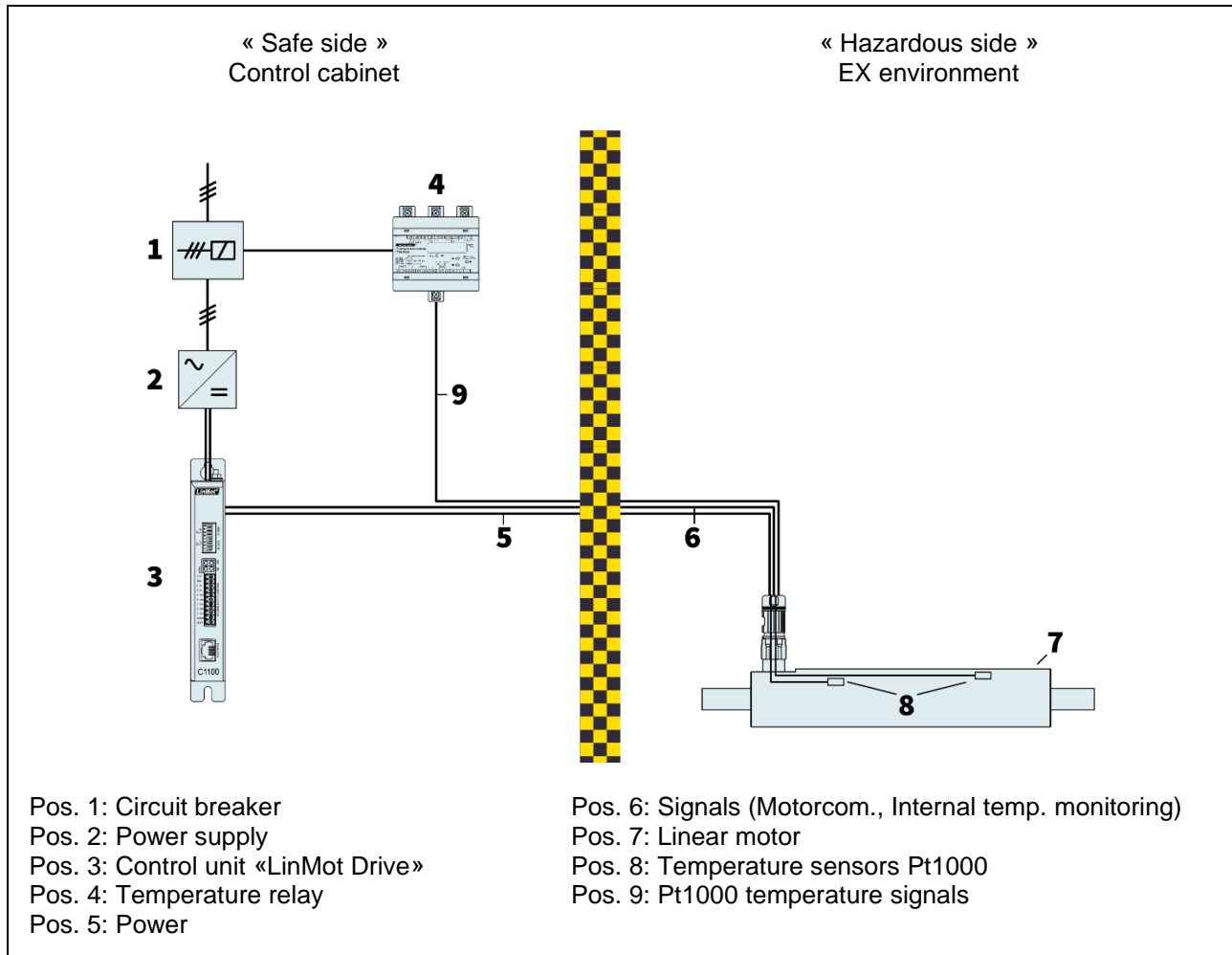

The motor is connected to the temperature relay and the LinMot control unit as shown in the diagram above. The terminal assignment of the control unit and the temperature relay can be found in the respective operating instructions. LinMot uses the TR210 from Ziehl (data sheet at <https://www.ziehl.com/en/products/?filterP=&filterG=&view=detail&detail=32>) as temperature relay. The connector assignment of the motor is shown in chapter 3.9.



- Connect or disconnect the motor plug only when there is no live voltage on the servo drive. Use only the original K10-Ex cable LinMot for the motor connection. Self-fabricated cables must be inspected carefully prior to commissioning. An incorrect motor cable can damage the motor and/or the servo drive.
- The motor plug must be connected to the cable by tightening the cable plug. The torque is 5 Nm and can be applied using the size 27 WAF.
- In addition to the safety regulations in this operation manual, be sure to follow the safety instructions in the operation manuals for the temperature relay and the LinMot control unit.



For the temperature relay, the limits for both temperature sensors must be set as follows:
Temperature class T4 (max. surface temperature = 135 °C) = 135 °C
Temperature class T6 (max. surface temperature = 85 °C) = 85 °C

4.7 Check before commissioning

Prior to commissioning, important components should be tested. See the table below.

When	What	Task
Prior to commissioning	Electrical connection	Tighten the plug thread. (Torque 5 Nm)
	Tightness	Check that external bearings are securely threaded onto the stator with no gap. (Torque 6 Nm)
	Ease of movement	Align the motor for load attachment so that the slider can move freely.

4.8 Design of water cooling

This paragraph relates to the ATEX linear motor versions with liquid cooling (motor identification numbers with the suffix –FC). The heat produced by the motor is dissipated by the liquid cooling. If the motor is operated with a liquid-cooling, the continuous force value increases many times in comparison with the self-cooling.

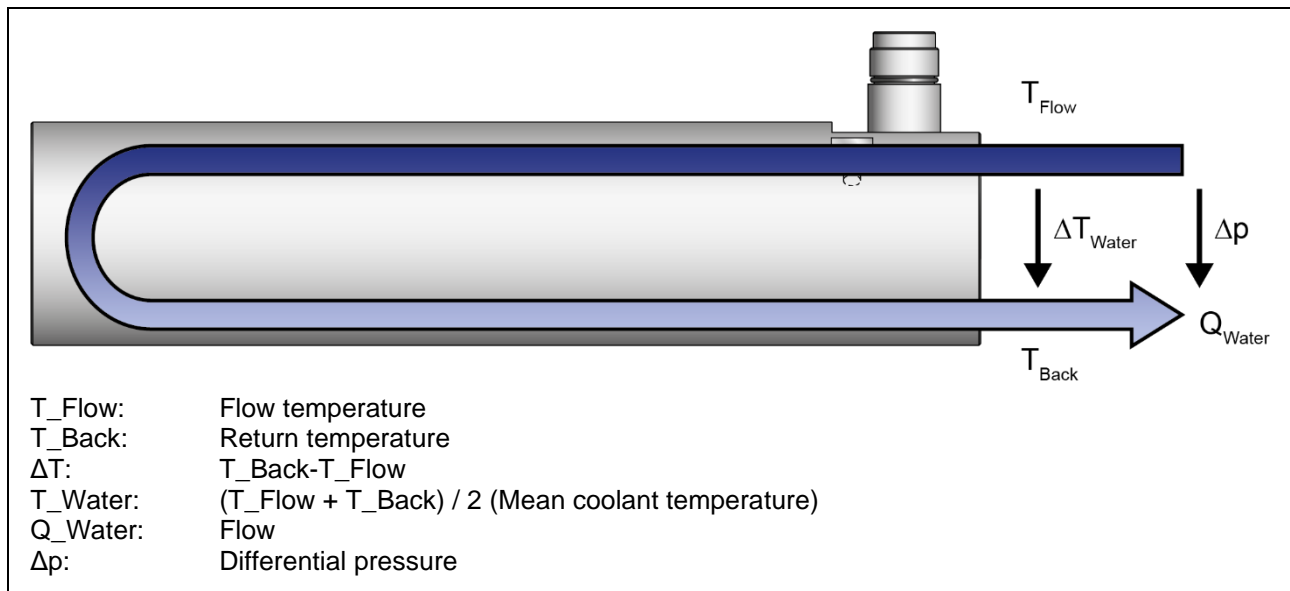

With the water cooling, the coolant is passed through the cooling circuit of the motor flange.

Starting from the adjusted mean coolant temperature T_{Water} all other parameters of the cooling circuit may be dimensioned based on the diagrams referred to:

- $T_{Water} \rightarrow P_{v_Max}$ (Continuous power dissipation) $\rightarrow Q_{Water} \rightarrow \Delta p$

The design is illustrated by an example in the following.

4.8.1 Determination of the max. possible amount of cont. power dissipation Pv_Max

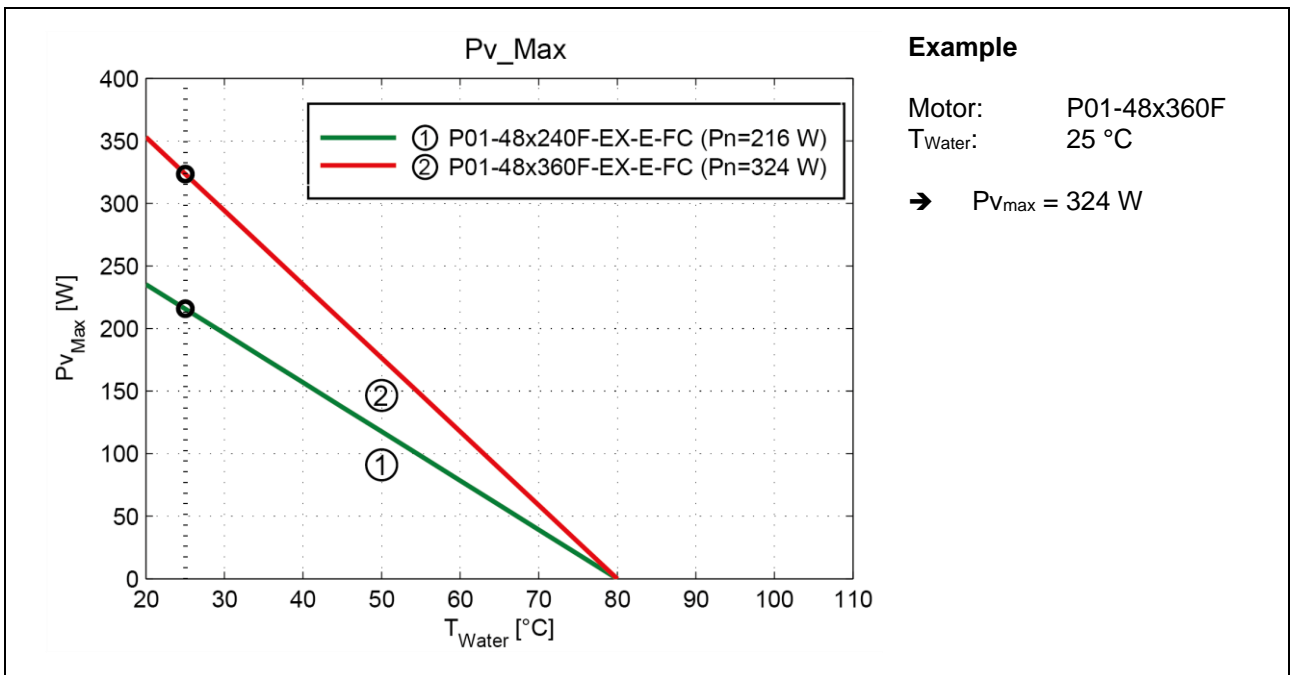

- The coolant temperature must not fall below the ambient temperature, otherwise there is a risk of condensation.
- When used and stored in a frost-prone area, corrosion protection (e.g. Clariant) has to be added.

4.8.2 Determination of water flow Q

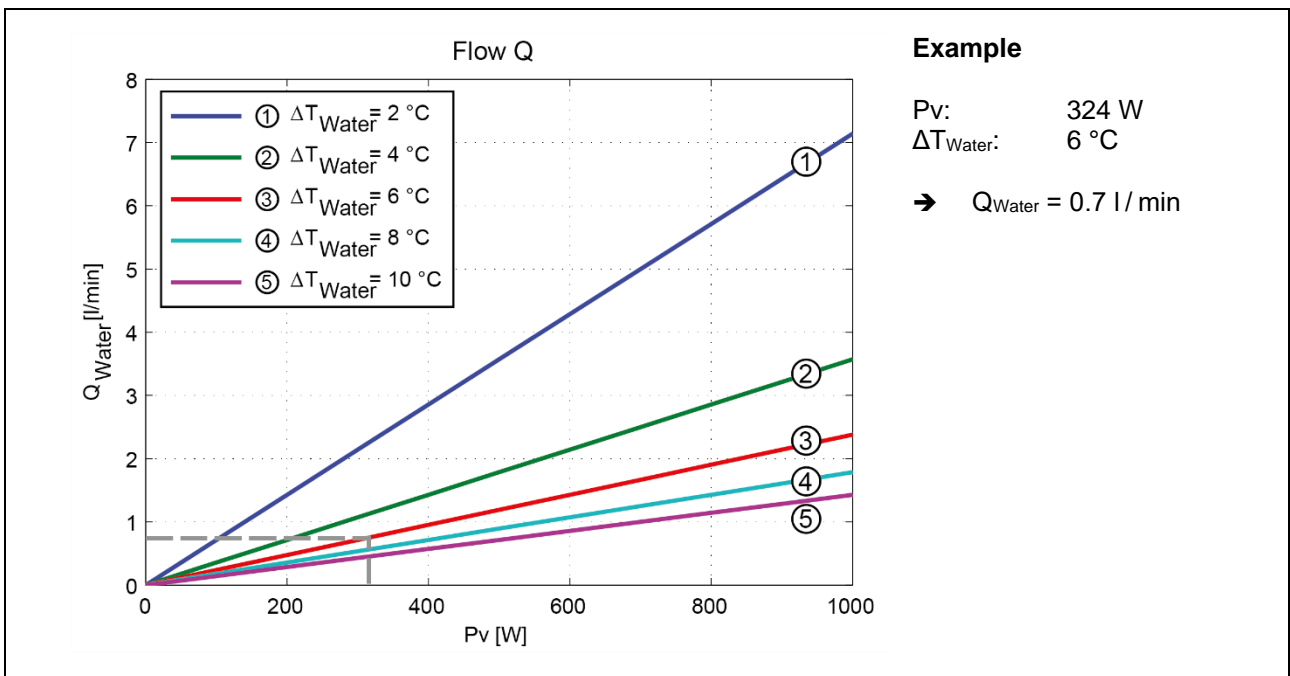

To achieve a very regular cooling of the motor, the max. difference between flow and return temperature should not exceed 10 °C.

4.8.3 Determination of water pressure Δp

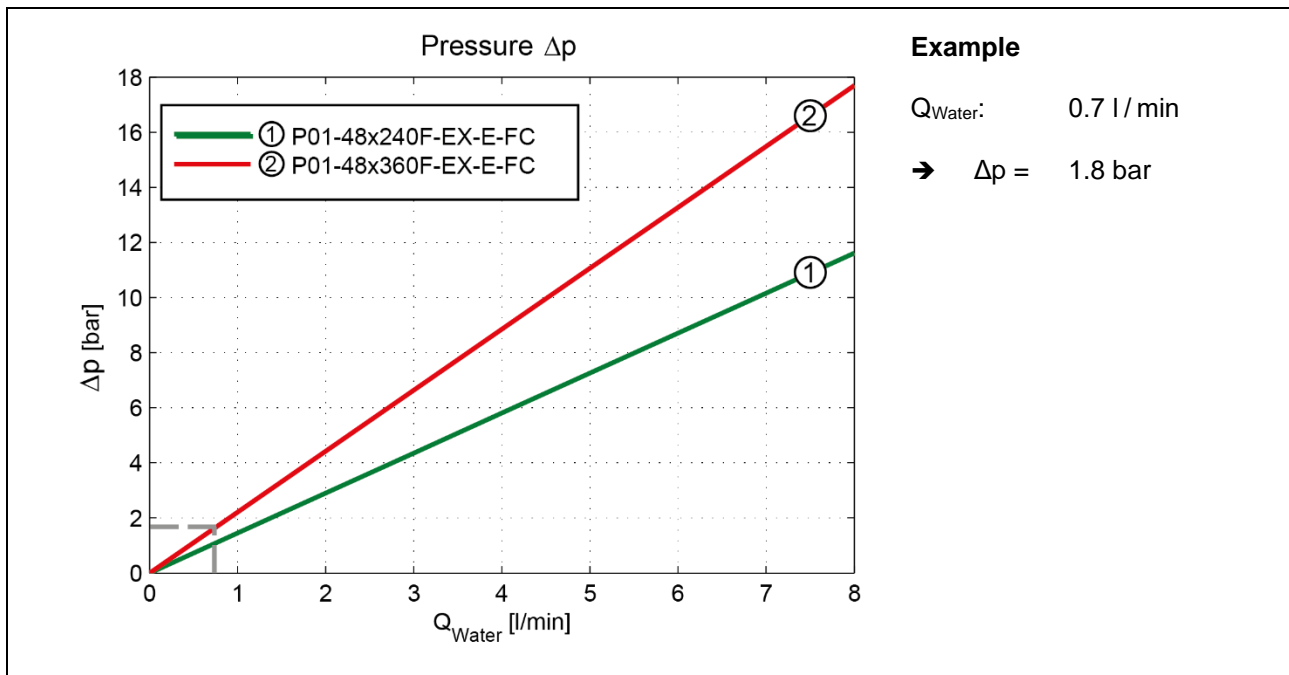

The required water pressure to inject the required water flow depends on the hydraulic resistance of the cooling circuit.

4.8.4 Corrosion protection

It is advised to add a corrosion protection into the cooling medium (water). A suitable agent can be, for example, Protectogen C Aqua by Clariant. Information of the mixing ratio between the cooling medium and the corrosion protection agent can be taken from the manufacturer's instructions.



- Mixing of various corrosion protection agents is to be avoided.
- Corrosion protection products must be matched to the materials of the cooling circuit.
- The cooling system consists of copper tubing.

4.8.5 Cooling line connection

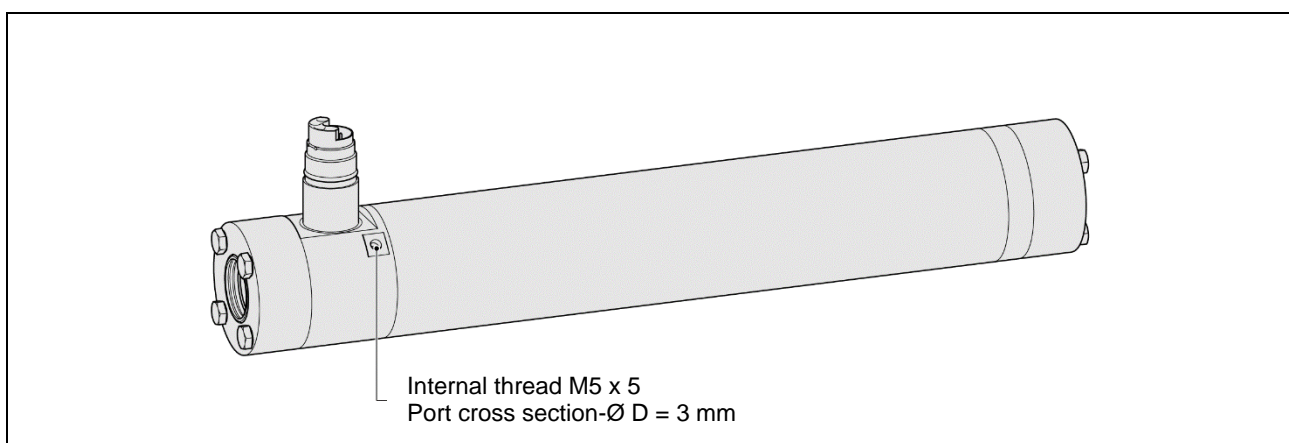

Two threaded connections are used for the inflow and outflow of the cooling medium to and from the stator (see illustration above). The connection can be implemented as an M5 thread.

5 Accessories

5.1 Slider mounting kit fixed bearing

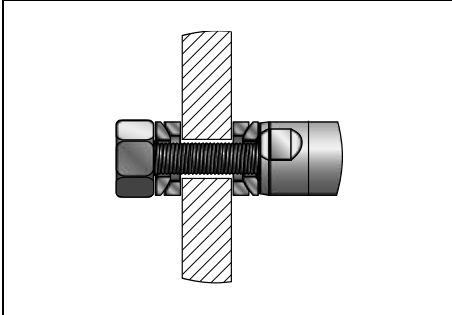

Slider mounting kit consists of a spring washer, a pair of spherical washers, and a pair of conical seats. It allows the slider to be fixed in the direction of motion. It also helps to compensate for radial and angle offset.

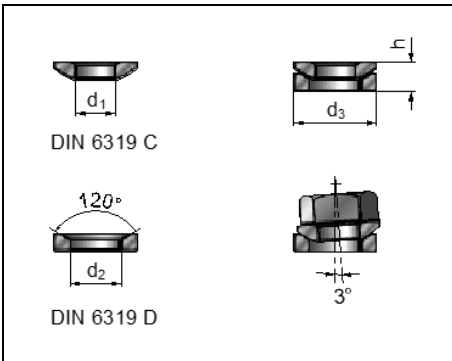

Material

Spherical washer / conical seat: Stainless steel

Item	Item-No.	Slider	Thread	d1	d2	d3	h
PLF01-28-SS (Edelstahl)	0150-3297	27mm 28mm	M10	10.5mm (0.41in)	12mm (0.47in)	21mm (0.83in)	6.5mm (0.26in)

Ordering information

Item	Description	Item-No.
PLF01-28-SS	Fixed End Washer Set for 27/28 mm sliders, SS consisting of spherical washer, conical seat and washer	0150-3297

5.2 Cooling Flange

The motor can also be mounted using a cooling flange. You will find the mounting diagram below.

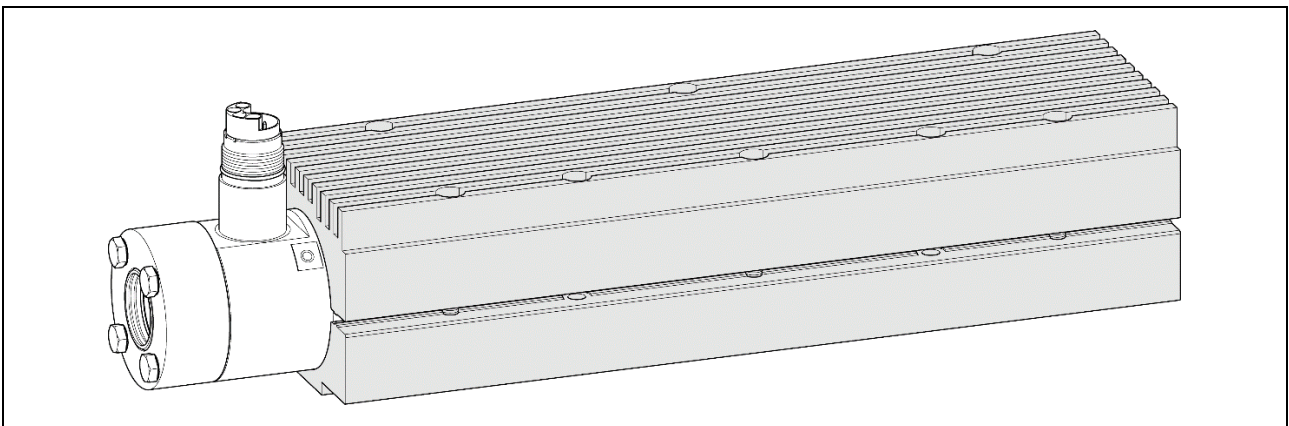

Ordering Information

Item	Description	Item-No.
PF01-48x330-SSC	Flange 48x330mm-SSC	0150-4350

6 Maintenance and test instructions

The person responsible for operating the motors must ensure that the prescribed maintenance work is carried out. The following maintenance schedule is designed for use in hazardous areas (see section 2.1 Intended use).

The inspection cycles are subdivided below into the "Vertical" and "Horizontal" applications.



Mechanical maintenance work with pointed tools must be carried out outside the explosive atmosphere.

6.1 Maintenance schedule

Vertical Application	Horizontal Application	What	Action
10 million movement cycles each or 1200 friction kilometres	5 million movement cycles each or 600 friction kilometres	Bearing clearance Abrasion Ease of movement	Check for bearing clearance, abrasion and ease of movement. The bearing must be replaced if there is clear evidence of wear or sluggishness of the slider.
		Slider	Check that the slider surface is clean and not scratched. Scratched sliders must be replaced, otherwise clean sliders.
		Electrical Connection	Tighten the plug screw connection. (Tightening torque 5 Nm according to section "Electrical connection of the motor")
		Water cooling	Check whether the cooling circuit is permanently guaranteed.
		Tightness	Check whether the external bearings are still firmly screwed onto the stator without a gap. (Tightening torque 6 Nm according to section "Mounting the motor")
		Case	Ensure that no thick layers of dust form on the housing and external bearings. Large deposits disturb the heat radiation.
50 million movement cycles each or 6000 friction kilometres	25 million movement cycles each or 3000 friction kilometres	External bearings and wipers	Replace the plastic bearing and the wiper on both sides (see section "Mounting the motor").
		Slider	Check that the slider surface is clean and not scratched. Scratched sliders must be replaced, otherwise clean sliders.
		Electrical Connection	Tighten the plug screw connection. (Tightening torque 5 Nm according to section "Electrical connection of the motor")
		Water cooling	Check whether the cooling circuit is permanently guaranteed.
		Tightness	Check whether the external bearings are still firmly screwed onto the stator without a gap. (Tightening torque 6 Nm according to section "Mounting the motor")
		Case	Ensure that no thick layers of dust form on the housing and external bearings. Large deposits disturb the heat radiation.
		Ease of movement	If friction is noticeable during the movement of the rotor, the motor must be switched off immediately. Check the alignment of the load guide and the rotor.

6.2 Cleaning in assembled state

- **Attention:** Strong magnetic attraction forces! (note section «Warning signs») Use non magnetic material (e.g. wood) to cover close-by iron constructions.
- Position the slider at the top and clean the visible slider area with a soft disposable paper, ideally with the aid of LU06 cleaning spray (alternatively methylated spirits or alcohol).
- Move the slider down and clean the visible slider area with a soft disposable paper, ideally with the aid of LU06 cleaning spray (alternatively methylated spirits or alcohol).

6.3 Cleaning in disassembled state

- Pull the sliders carefully out of the stator.
Attention: Strong magnetic attraction forces! (note section «Warning signs») Use non magnetic material (e.g. wood) to cover close-by iron constructions.
- Clean slider and stator with a soft disposable paper, ideally with the help of LU06 cleaning spray (or methylated spirits or alcohol).
- Finally, slider should be inserted according to the chapter «Mounting the motor».

6.4 Cleaning agent

For the cleaning of LinMot stators and sliders cleaning agent spray LU06 is recommended.

Ordering information

Item	Description	Item-No.
LU06-250	Klüberfood NH1 4-002 Spray* (250 ml)	0150-2394
* LinMot Spray LU06 corresponds to KLÜBERFOOD NH1 4-002 which was developed for the food processing industry.		

6.5 Stator checking

The following tables show the resistive value between the different connector pins for each stator type. If the value is not within a range of +/- 10% the stator may be damaged (temperature of the stator for all measurements: 20°C).

PS01-48x150G-HP-EX-E (Art: 0150-4370)

PS01-48x150G-HP-EX-E-FC (Art: 0150-4371)

Phase1+ / Phase1-	Red / Pink	Pin A / Pin B	0.8 Ω
Phase2+ / Phase2-	Blue / Grey	Pin C / Pin D	0.8 Ω
5V / GND	White / Inner shield	Pin 1 / Pin 2	155 Ω
Sensor Sine / GND	Yellow / Inner shield	Pin 3 / Pin 2	33 kΩ
Sensor Cosine / GND	Green / Inner shield	Pin 4 / Pin 2	33 kΩ
Temp. Sensor / GND	Black / Inner shield	Pin 5 / Pin 2	10 kΩ
Phase / GND	-	Pin 1 - 4 / Pin 2	> 20 MΩ
All Pin / Shield	-	Pin A - 10 / Housing	> 20 MΩ
Pt1000 1	-	Pin 7, 8	1080 Ω @ 20 °C
Pt1000 2	-	Pin 9, 10	1080 Ω @ 20 °C

PS01-48x240F-HP-EX-E (Art: 0150-4365)**PS01-48x240F-HP-EX-E-FC (Art: 0150-4366)**

Phase1+ / Phase1-	Red / Pink	Pin A / Pin B	1.1 Ω
Phase2+ / Phase2-	Blue / Grey	Pin C / Pin D	1.1 Ω
5V / GND	White / Inner shield	Pin 1 / Pin 2	155 Ω
Sensor Sine / GND	Yellow / Inner shield	Pin 3 / Pin 2	33 k Ω
Sensor Cosine / GND	Green / Inner shield	Pin 4 / Pin 2	33 k Ω
Temp. Sensor / GND	Black / Inner shield	Pin 5 / Pin 2	10 k Ω
Phase / GND	-	Pin 1 - 4 / Pin 2	> 20 M Ω
All Pin / Shield	-	Pin A - 10 / Housing	> 20 M Ω
Pt1000 1	-	Pin 7, 8	1080 Ω @ 20 °C
Pt1000 2	-	Pin 9, 10	1080 Ω @ 20 °C

PS01-48x360F-HP-EX-E (Art: 0150-4367)**PS01-48x360F-HP-EX-E-FC (Art: 0150-4368)**

Phase1+ / Phase1-	Red / Pink	Pin A / Pin B	1.5 Ω
Phase2+ / Phase2-	Blue / Grey	Pin C / Pin D	1.5 Ω
5V / GND	White / Inner shield	Pin 1 / Pin 2	155 Ω
Sensor Sine / GND	Yellow / Inner shield	Pin 3 / Pin 2	33 k Ω
Sensor Cosine / GND	Green / Inner shield	Pin 4 / Pin 2	33 k Ω
Temp. Sensor / GND	Black / Inner shield	Pin 5 / Pin 2	10 k Ω
Phase / GND	-	Pin 1 - 4 / Pin 2	> 20 M Ω
All Pin / Shield	-	Pin A - 10 / Housing	> 20 M Ω
Pt1000 1	-	Pin 7, 8	1080 Ω @ 20 °C
Pt1000 2	-	Pin 9, 10	1080 Ω @ 20 °C

7 Storage, transport, installation height

- LinMot stators and sliders may only be transported and stored in their original packaging.
- The sliders should only be removed from the packaging during installation.
- The storage room must be dry, dust-free, frost-free and vibration-free.
- The relative humidity should be less than 60 %.
- Prescribed storage temperature: -15 °C...70 °C
- The motor must be protected from extreme weather conditions.
- The ambient air must not contain aggressive gases.
- The maximum installation altitude is 2000 m above sea level.
Above 1,000 m, a derating of 0.5% per 100 m must be taken into account for the nominal force in the case of air cooling.

8 Declaration of Conformity

Wir
We
Nous

NTI AG
Bodenaeckerstrasse 2
8957 Spreitenbach

erklären in alleiniger Verantwortung, dass das Produkt
declare under our sole responsibility that the product
declarons sous notre seule responsabilité que le produit

Product	Item-No.
PS01-48x150G-HP-EX-E	0150-4370
PS01-48x150G-HP-EX-E-FC	0150-4371
PS01-48x240F-HP-EX-E	0150-4365
PS01-48x240F-HP-EX-E-FC	0150-4366
PS01-48x360F-HP-EX-E	0150-4367
PS01-48x360F-HP-EX-E-FC	0150-4368

konform ist mit den Anforderungen der Richtlinien,
is conform to the provisions of directives,
est conforme aux exigences des directives,

2014/34/EU (ATEX)

2014/30/EU (EMC)

gestützt auf die folgenden Normen,
based on the following standards,
base aux normes suivants,

EN IEC 60079-0: 2018

EN 60079-31: 2014

EN 60079-7: 2015

EN IEC 61000-6-2: 2005

EN IEC 61000-6-4: 2007+A1: 2011

Das Produkt muss in strikter Übereinstimmung mit den Installationsanweisungen in der Installationsanleitung, die bei der NTI AG angefordert werden kann, montiert und verwendet werden.

The product must be mounted and used in strict accordance with the installation instructions contained within the installation guide, a copy of which may be obtained from NTI AG.

Le produit doit être monté et utilisé en stricte conformité avec les instructions d'installation contenues dans le guide d'installation, dont une copie peut être obtenue auprès de NTI AG.

Notified Body: Eurofins N° 1258

Certificate N° SEV15 ATEX 0133 X

Spreitenbach, 21.03.2023



Dr.-Ing. Ronald Rohner
CEO NTI AG



Dr.-Ing. Marco Hitz
RESPONSIBLE FOR DOCUMENTATION

9 IECEx Conformity certificate

		<h2>IECEX Certificate of Conformity</h2>	
INTERNATIONAL ELECTROTECHNICAL COMMISSION IEC Certification System for Explosive Atmospheres <small>for rules and details of the IECEx Scheme visit www.iecex.com</small>			
Certificate No.:	IECEX SEV 15.0015X	Page 1 of 4	<u>Certificate history:</u>
Status:	Current	Issue No: 3	Issue 2 (2016-05-19) Issue 1 (2016-03-09) Issue 0 (2015-11-03)
Date of Issue:	2020-07-24		
Applicant:	NTI AG Bodenackerstrasse 2 8957 Spreitenbach Switzerland		
Equipment:	PS01-48 Linear motor		
Optional accessory:			
Type of Protection:	e, t		
Marking:	Ex eb IIC T6...T4 Gb Ex tb IIIC T85 °C...135 °C Db		
Approved for issue on behalf of the IECEx Certification Body:		Martin Plüss Manager Product Certification	
Position:		 <hr/> 2020-07-24	
Signature: (for printed version)			
Date:			
1. This certificate and schedule may only be reproduced in full. 2. This certificate is not transferable and remains the property of the Issuing body. 3. The Status and authenticity of this certificate may be verified by visiting www.iecex.com or use of this QR Code.			
Certificate issued by: Eurofins Electric & Electronic Product Testing AG Luppenstrasse 3 CH-8320 FEHRALTORF Switzerland		 eurofins E&E	



IECEX Certificate of Conformity

Certificate No.: **IECEX SEV 15.0015X**

Page 2 of 4

Date of issue: 2020-07-24

Issue No: 3

Manufacturer: **NTI AG**
Bodenackerstrasse 2
8957 Spreitenbach
Switzerland

Additional
manufacturing
locations:

This certificate is issued as verification that a sample(s), representative of production, was assessed and tested and found to comply with the IEC Standard list below and that the manufacturer's quality system, relating to the Ex products covered by this certificate, was assessed and found to comply with the IECEx Quality system requirements. This certificate is granted subject to the conditions as set out in IECEx Scheme Rules, IECEx 02 and Operational Documents as amended

STANDARDS :

The equipment and any acceptable variations to it specified in the schedule of this certificate and the identified documents, was found to comply with the following standards

IEC 60079-0:2017 Explosive atmospheres - Part 0: Equipment - General requirements
Edition:7.0

IEC 60079-31:2013 Explosive atmospheres - Part 31: Equipment dust ignition protection by enclosure "t"
Edition:2

IEC 60079-7:2015 Explosive atmospheres – Part 7: Equipment protection by increased safety "e"
Edition:5.0

This Certificate **does not** indicate compliance with safety and performance requirements other than those expressly included in the Standards listed above.

TEST & ASSESSMENT REPORTS:

A sample(s) of the equipment listed has successfully met the examination and test requirements as recorded in:

Test Report:

[CH/SEV/EXTR15.0017/03](#)

Quality Assessment Report:

[CH/SEV/QAR15.0004/02](#)



IECEx Certificate of Conformity

Certificate No.: **IECEx SEV 15.0015X**

Page 3 of 4

Date of issue: 2020-07-24

Issue No: 3

EQUIPMENT:

Equipment and systems covered by this Certificate are as follows:

PS01-48 Linear motor

Types:

PS01-48x150G-HP-EX-E
 PS01-48x150G-HP-EX-E-FC
 PS01-48x240F-HP-EX-E
 PS01-48x240F-HP-EX-E-FC
 PS01-48x360F-HP-EX-E
 PS01-48x360F-HP-EX-E-FC

Linear motor LinMot motors are direct-drive electromagnetic tubular linear motors. The main components of the motor are the stator and the slider. The slider, the so-called "magnet bar", consists of permanent magnets that are arranged with alternating polarization. The stator contains the windings and position sensors. The windings are fed with current at an appropriate electrical phase angle, like a permanently excited synchronous motor, thus producing a force in the desired direction. The motor has 3 (or 4) temperature sensors on the windings. These sensors can be used with a series x1100 or x1200 LinMot drive to read and analyze the absolute temperature. This makes it possible to determine the winding temperature and to shut off the motor in case of a fault. If the drive can no longer communicate with the motor, then it will shift to a fault state. Feedback is provided to the control system. The position is sensed by measuring the magnetic field of the slider. The stator is encapsulated and welded completely shut. ATEX linear motors can be equipped with a copper cooling system as an option.

SPECIFIC CONDITIONS OF USE: YES as shown below:

- The permissible ambient temperature range is 0 °C ... +60 °C.
- Always make sure that the external ground connection on the motor is connected to the PE of the machine
- Only for use with an inverter.
- Operation is allowed only in conjunction with a temperature relay and line protection
- Do not separate the power connector when energized
- Maintenance and service work may be performed only in a clean room with no explosive atmosphere. Dangerous ignition sources may arise when disassembling component parts



IECEx Certificate of Conformity

Certificate No.: **IECEX SEV 15.0015X**

Page 4 of 4

Date of issue: 2020-07-24

Issue No: 3

DETAILS OF CERTIFICATE CHANGES (for issues 1 and above)

- New bearings made of electrically conductive material with a longer service life
- Expansion with a new heat sink
- Extension of the permissible ambient temperature up to 60 °C
- New temperature sensor for the higher-level monitoring circuit
- Additional winding body material for higher service temperatures
- Deviations of the standard generation were checked in accordance with the actual current standard IEC 60079-0:2017 Edition 7.0.



10 EC Type examination certificate

(1) **EU-Type Examination Certificate**

- (2) Equipment or protective system intended for use in potentially explosive atmospheres - **Directive 2014/34/EU**
- (3) Certificate number: **SEV 15 ATEX 0133 X**
- (4) Product: PS01-48 Linear motor
Type See page 2
- (5) Manufacturer: NTI AG
- (6) Address: Bodenackerstrasse 2, 8957 Spreitenbach, Switzerland
- (7) The equipment and any acceptable variation thereto is specified in the schedule to this certificate and the documents therein referred to.
- (8) Eurofins, notified body No. 1258, in accordance with article 17 of Directive 2014/34/EU of the European parliament and of the council, dated 26 February 2014, certifies that this product has been found to comply with the essential health and safety requirements relating to the design and construction of products intended for use in potentially explosive atmospheres given in Annex II to the Directive.
The examination and test results are recorded in confidential report no 20CH-00249.X04
- (9) Compliance with the essential health and safety requirements has been assured by compliance with:
EN IEC 60079-0:2018
EN 60079-31:2014
EN 60079-7:2015
- Except in respect of those requirements listed at item 18 of the schedule.
- (10) If the sign «X» is placed after the certificate number, it indicates that the product is subjected to special conditions for safe use specified in the schedule to this certificate. The sign "U" is placed after the certificate number. It indicates that this certificate must not be mistaken for a certificate intended for an equipment or protective system. This partial certification may be used as a basis for certification of an equipment or protective system.
- (11) This EU type examination certificate relates only to design and construction of the specified product. Further requirements of this directive apply to the manufacturing process and supply of this product. These are not covered by this certificate.
- (12) The marking of the product shall include the following:

 II 2 G Ex eb IIC T6...T4 Gb
II 2 D Ex tb IIIC T85 °C...135 °C Db

Eurofins Electric & Electronic Product Testing AG
Notified Body ATEX

Martin Plüss
Product Certification



www.eurofins.ch

Fehraltorf, 2020-07-24

Issue: 3

Page 1 of 2

T8a_V01



(13)

Appendix

(14)

EU-Type Examination Certificate no. SEV 15 ATEX 0133 X

(15) **Description of product**

Types: PS01-48x150G-HP-EX-E PS01-48x150G-HP-EX-E-FC PS01-48x240F-HP-EX-E
 PS01-48x240F-HP-EX-E-FC PS01-48x360F-HP-EX-E PS01-48x360F-HP-EX-E-FC

Linear motor LinMot motors are direct-drive electromagnetic tubular linear motors. The main components of the motor are the stator and the slider. The slider, the so-called "magnet bar", consists of permanent magnets that are arranged with alternating polarization. The stator contains the windings and position sensors. The windings are fed with current at an appropriate electrical phase angle, like a permanently excited synchronous motor, thus producing a force in the desired direction. The motor has 3 (or 4) temperature sensors on the windings. These sensors can be used with a series x1100 or x1200 LinMot drive to read and analyze the absolute temperature. This makes it possible to determine the winding temperature and to shut off the motor in case of a fault. If the drive can no longer communicate with the motor, then it will shift to a fault state. Feedback is provided to the control system. The position is sensed by measuring the magnetic field of the slider. The stator is encapsulated and welded completely shut. ATEX linear motors can be equipped with a copper cooling system as an option.

Ratings:	U _{max} : 72 V DC
	I _{max} : 32 A
Classification of installation and use:	stationary
Ingress protection:	IP68
Rated ambient temperature range (°C):	0 °C ... +60 °C

(16) **Specific conditions of use**

- Always make sure that the external ground connection on the motor is connected to the PE of the machine
- Only for use with an inverter.
- Operation is allowed only in conjunction with a temperature relay and line protection
- Do not separate the power connector when energized
- Maintenance and service work may be performed only in a clean room with no explosive atmosphere. Dangerous ignition sources may arise when disassembling component parts

(17) **Essential health and safety requirements**

In addition to the essential health and safety requirements (EHSRs) covered by the standards listed at item 9, the following are considered relevant to this product, and conformity is demonstrated in the report:

Clause	Subject
None	

(18) **Drawings and Documents**

See test report "Manufacturer's Documents"



ALL LINEAR MOTION FROM A SINGLE SOURCE

Europe / Asia Headquarters

NTI AG - LinMot & MagSpring

Bodenaeckerstrasse 2
CH-8957 Spreitenbach
Switzerland

Sales / Administration: +41 56 419 91 91
office@linmot.com

Tech. Support: +41 56 544 71 00
support@linmot.com

Web: <https://www.linmot.com/>

Visit <https://linmot.com/contact/> to find a distributor near you.

North / South America Headquarters

LinMot USA Inc.

N1922 State Road 120, Unit 1
Lake Geneva, WI 53147
USA

Sales / Administration: 262.743.2555
usasales@linmot.com

Tech. Support: 262.743.2555
usasupport@linmot.com

Web: <https://www.linmot-usa.com/>