

Installation Guide Power Supply

ENG

Type S02-72/1000

Power range 1000 W



Important Notice:

Please note that we use machine translation to provide documents in your local language. It is possible that not all texts will be translated correctly. If you have any questions or discrepancies regarding the accuracy of the information in the translated version, please read the original English version (0185-0118-E).

Content

1	General Information	3
1.1	Introduction	3
1.2	Explanation of Symbols	3
1.3	Qualified Personnel	3
1.4	Liability	3
1.5	Copyright	3
2	Safety Instructions	4
2.1	Personal Safety	4
2.2	Application as directed	4
2.3	Transport, Storage	4
2.4	Installation	4
2.5	Electrical Connection	5
2.6	Operation	5
2.7	Protection of Persons	5
3	Mains Connection and Grounding	6
4	Description of the Connectors / Interfaces	7
4.1	Protective Earth	7
4.2	X30	7
4.3	X56	7
5	LED Blink Codes	7
6	Physical Dimension	8
7	Output Voltage Regulation	9
8	Load Behavioral	9
9	Parallel Connection	11
10	Ordering Information	12
11	International Certificates	12
12	Declaration of Conformity and CE-marking	18
13	UK Declaration of Conformity UKCA-Marking	19

1 General Information

1.1 Introduction

Observe the following safety instructions and the instructions on the unit (the term "unit" in the following refers to a single power supply module) as well as all the information in this manual in order to prevent danger to persons and hazards or damage to the unit and other connected products.

1.2 Explanation of Symbols



Triangular warning symbols warn against a danger.



Round command symbols tell what to do.

1.3 Qualified Personnel

All work such as transport, installation, commissioning and service is only allowed to be carried out by qualified personnel. Qualified personnel in the sense of the safety instructions in this documentation are persons who are familiar with the transport, installation, assembly, commissioning and operation of the product and who have the appropriate qualifications.

This manual must be read carefully before transport, installation, commissioning, service and all safety-related information must be adhered to.

1.4 Liability

NTI AG (as manufacturer of LinMot linear motors and MagSpring products) excludes all liability for damages and expenses caused by incorrect use of the products. This also applies to false applications, which are caused by NTI AG's own data and notes, for example in the course of sales, support or application activities. It is the sole responsibility of the user to check the information and information provided by NTI AG regarding their safety-relevant correctness. In addition, the entire responsibility for safety-related product functionality lies exclusively with the user. Product warranties are void if products are used with stators, sliders, servo drives or cables not manufactured by NTI AG unless such use was specifically approved by NTI AG. NTI AG's warranty is limited to repair or replacement as stated in our standard warranty policy as described in our "terms and conditions" previously supplied to the purchaser of our equipment (please request copy of same if not otherwise available). Further reference is made to our general terms and conditions.

1.5 Copyright

This work is protected by copyright.

Under the copyright laws, this publication may not be reproduced or transmitted in any form, electronic or mechanical, including photocopying, recording, microfilm, storing in an information retrieval system, not even for training purposes, or translating, in whole or in part, without the prior written consent of NTI AG.

LinMot® is a registered trademark of NTI AG.

2 Safety Instructions

2.1 Personal Safety

**For your personal safety**

Disregarding the following safety measures can lead to severe injury to persons and damage to material:

- Only use the product as directed.
- Never commission the product in the event of visible damage.
- Never commission the product before assembly has been completed.
- Do not carry out any technical changes on the product.
- Only use the accessories approved for the product.
- Only use original spare parts from LinMot.
- Observe all regulations for the prevention of accidents, directives and laws applicable on site.
- Transport, installation, commissioning and maintenance work must only be carried out by qualified personnel.
 - Observe IEC 364 and CENELEC HD 384 or DIN VDE 0100 and IEC report 664 or DIN VDE 0110 and all national regulations for the prevention of accidents.
 - According to the basic safety information, qualified, skilled personnel are persons who are familiar with the assembly, installation, commissioning, and operation of the product and who have the qualifications necessary for their occupation.
- Observe all specifications in this documentation.
 - This is the condition for safe and trouble-free operation and the achievement of the specified product features.
 - The procedural notes and circuit details described in this documentation are only proposals. It is up to the user to check whether they can be transferred to the particular applications. NTI AG / LinMot does not accept any liability for the suitability of the procedures and circuit proposals described.
- LinMot servo drives, power supplies and the accessory components can include live and moving parts (depending on their type of protection) during operation. Surfaces can be hot.
 - Non-authorized removal of the required cover, inappropriate use, incorrect installation or operation create the risk of severe injury to persons or damage to material assets.
 - For more information, please see the documentation.
- High amounts of energy are produced in the power supply. Therefore, it is required to wear personal protective equipment (body protection, headgear, eye protection, hand guard).

2.2 Application as directed

- LinMot power supplies are components, which are designed for installation in electrical systems or machines. They are not to be used as domestic appliances, but only for industrial purposes according to EN 61000-3-2.
- When power supplies are installed into machines, commissioning (i.e. starting of the operation as directed) is prohibited until it is proven that the machine complies with the regulations of the EC Directive 2006/42/EG (Machinery Directive); EN 60204 must be observed.
- Commissioning (i.e. starting of the operation as directed) is only allowed when there is compliance with the EMC Directive (2014/30/EU).
- The technical data and supply conditions can be obtained from the nameplate and the documentation. They must be strictly observed.

2.3 Transport, Storage

- Please observe the notes on transport, storage, and appropriate handling.
- Observe the climatic conditions according to the technical data.

2.4 Installation

- The power supply must be installed and cooled according to the instructions given in the corresponding documentation.
- The ambient air must not exceed degree of pollution 2 according to EN IEC 61800-5-1.

- Ensure proper handling and avoid excessive mechanical stress. Do not bend any components and do not change any insulation distances during transport or handling. Do not touch any electronic components and contacts.
- Power supplies contain electrostatic sensitive devices, which can easily be damaged by inappropriate handling. Do not damage or destroy any electrical components since this might endanger your health!

2.5 Electrical Connection



When working on live power supplies, observe the applicable national regulations for the prevention of accidents.



The electrical installation must be carried out according to the appropriate regulations (e.g. cable cross-sections, circuit breakers, fuses, PE connection). Additional information can be obtained from the documentation.



This product can cause high-frequency interferences in non-industrial environments, which can require measures for interference suppression.

2.6 Operation

- If necessary, systems containing switching power supplies must be equipped with additional monitoring and protective devices in accordance with the applicable safety regulations (e.g. law on technical equipment, regulations for the prevention of accidents).
- After the power supply has been disconnected from the supply voltage, all live components and power connections must not be touched immediately because capacitors can still be charged. Please observe the corresponding stickers on the power supply. All protection covers and doors must be shut during operation.

2.7 Protection of Persons



The power terminals L1, L2, L3 and PWR+, PGND remain energized for a maximum of five minutes after the power supply has been disconnected.



Before servicing, disconnect supply, wait 5 minutes and measure between PWR+ and PGND to be sure that the capacitors have discharged below 42 VDC.



The housing of the power supply can have an operating temperature of $> 80\text{ °C}$: Contact with the heat sink results in burns.

3 Mains Connection and Grounding

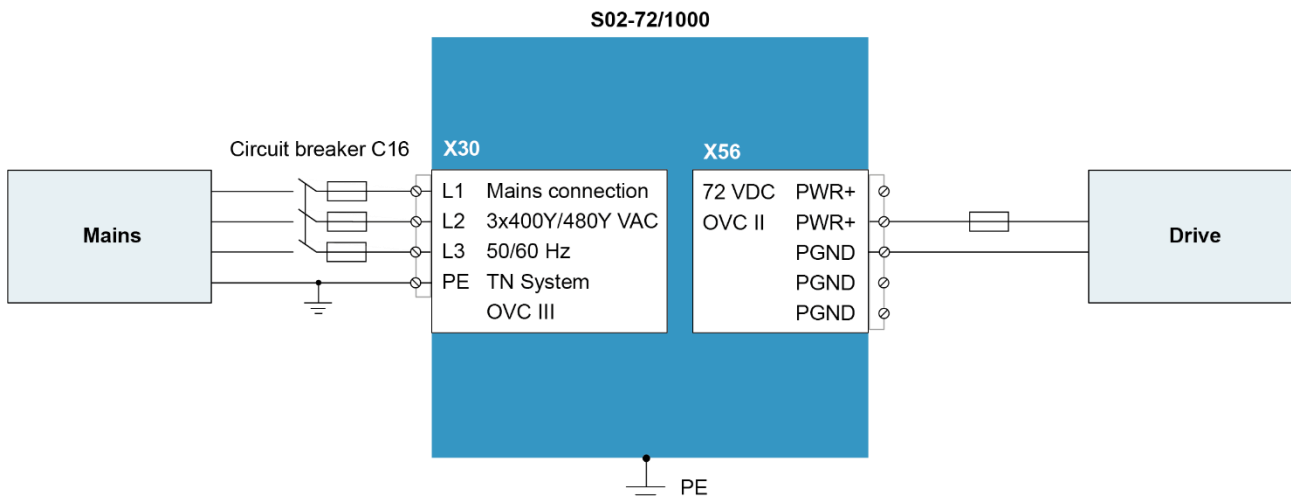

Figure 3-1: Mains connection, grounding and overvoltage category (OVC)



In order to assure a safe and error free operation, and to avoid severe damage to system components, **all system components must be well grounded to protective earth PE.** This includes both LinMot and all other control system components on the same ground bus.



Each system component should be tied directly to the ground bus (**star pattern**). Daisy chaining from component to component is forbidden.



Power supply connectors must not be connected or disconnected while DC voltage is present. (Capacitors in the power supply may not fully discharge for several minutes after input voltage has been disconnected). Failure to observe these precautions may result in severe damage to electronic components in LinMot motors and/or drives.



Integral solid state short circuit protection does not provide branch circuit protection. Branch circuit protection must be provided in accordance with the National Electrical Code / Canadian Electrical Code, and any additional local codes.



Do not switch Power Supply DC Voltage. All power supply switching and E-Stop breaks should be done to the AC supply voltage of the power supply. Failure to observe these precautions may result in severe damage to the power supply unit.

4 Description of the Connectors / Interfaces

4.1 Protective Earth

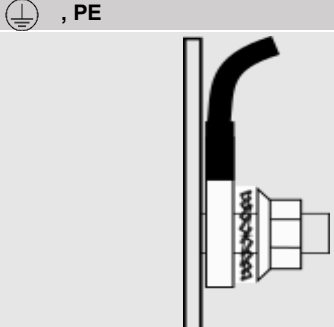
	Protective Earth	
	1	⊕, PE
<ul style="list-style-type: none"> - Use min 4 mm² (AWG 11) - Tightening Torque 2 Nm (18 lbin) 		

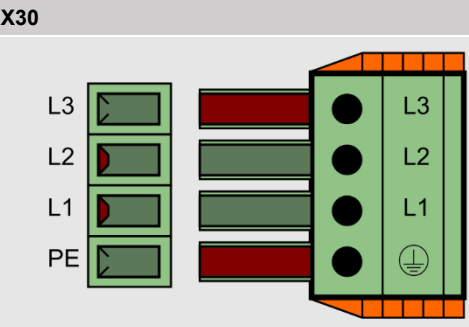

4.2 X30

	Supply Mains	
	2, 3, 4	L1, L2, L3
1	PE	PE, Protective Earth
<ul style="list-style-type: none"> - Tightening torque: 0.8 Nm (7 lbin) - Use 60/75°C copper conductors only - Conductor cross-section 2.5 - 4 mm² / AWG 24 - 12 - Stripping length: 10 mm - external circuit breaker (16 A Type C UL listed) required - total conductor length must be 10 m or less - Suitable for use on a circuit with Short Circuit Current Rating (SCCR) not more than 5 kA rms symmetrical. 		

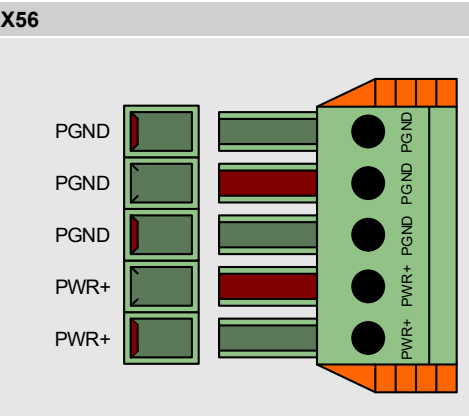
4.3 X56

	DC Output	
	4, 5	PWR+
1, 2, 3	PGND	Negative output
<ul style="list-style-type: none"> - Tightening torque: 0.8 Nm (7 lbin) - Use 60/75°C copper conductors only - Conductor cross-section 2.5 - 4 mm² / AWG 24 - 12 - Stripping length: 10 mm - total conductor length must be 10 m or less 		

5 LED Blink Codes

LED Blink Codes		
	enabled	
	error	
enabled	error	Description
On	Off	Power supply is enabled
Off / On	On	Error occurred

6 Physical Dimension

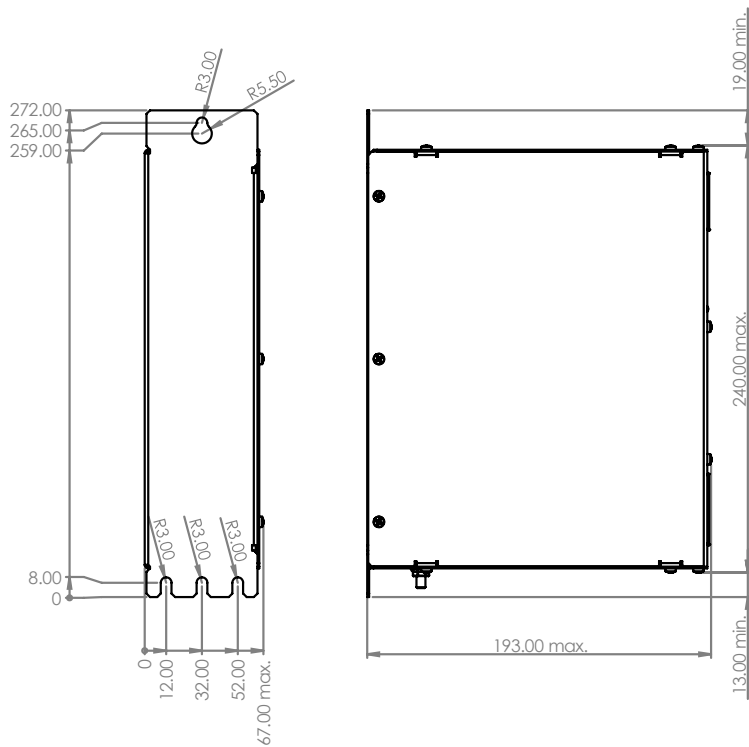

in mm

Figure 6-1: Drawing of the power supply

S02-72/1000-xS Power Supplies		
Width	mm	67
Height	mm	240
Height with fixings	mm	272
Depth	mm	193
Weight	kg	2.6
Mounting screws		up to M5
Mounting distance	mm	257 - 262
Case, degree of protection	IP	20
Storage temperature	°C	-25...40
Transport temperature	°C	-25...70
Operating temperature	°C	0...40 at rated data
Relative humidity		< 95% (non-condensing)
Pollution		Pollution degree 2 acc. EN IEC 61800-5-1
Altitude		< 2000 m above sea level
Max. power dissipation	W	100
Mounting place		Control cabinet with minimum protection class IP54
Mounting position		vertical
Minimum distance between surrounding components and air admission and air exit holes	mm	50

7 Output Voltage Regulation

The regulated output voltage depends on the output load. This characteristic makes it possible to connect power supplies in parallel.

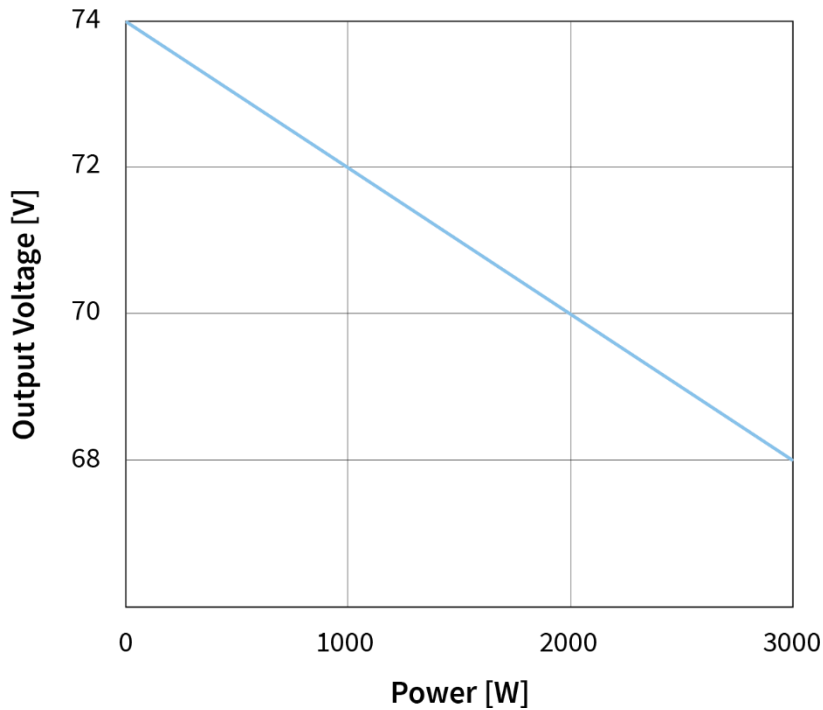

Figure 7-1: Output Voltage Regulation

8 Load Behavioral

During power boost mode, the power supply can triple its output power for a limited time. The overload is calculated over a period of 4 seconds. If the overload stays below 1000 W*s during 4 seconds, no cool down phase is required (green area in Figure 8-1).

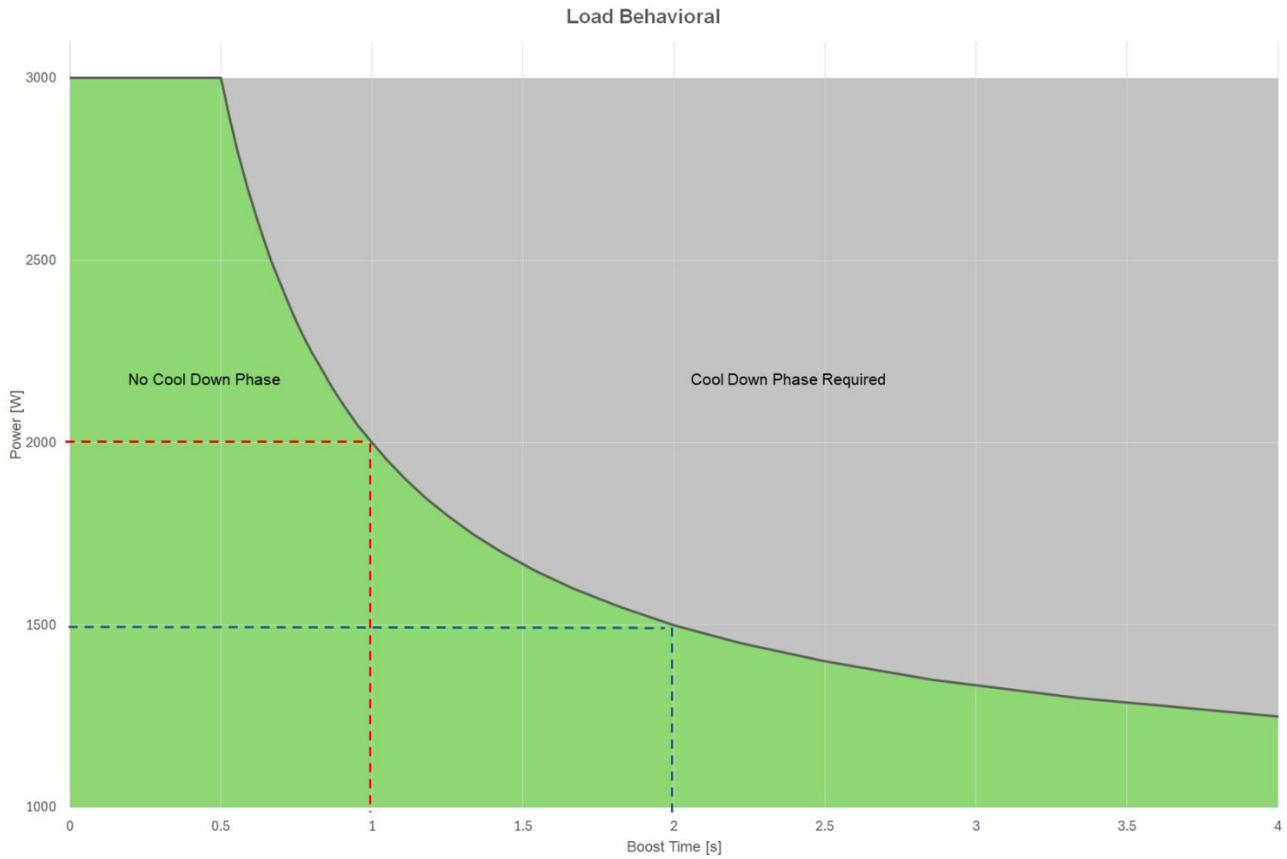

Figure 8-1: Load Behavioral

Example1: Within a period of 4 seconds, the power supply may deliver 1500 W during a total time of up to 2 seconds, without requiring a cool down phase (blue box).

Example2: Within a period of 4 seconds, the power supply may deliver 2000 W during a total time of up to 1 second, without requiring a cool down phase (red box).

The required cool down phase can be found in Figure 8-2. The RMS power of the power supply should not exceed 1 kW with the power boost included.

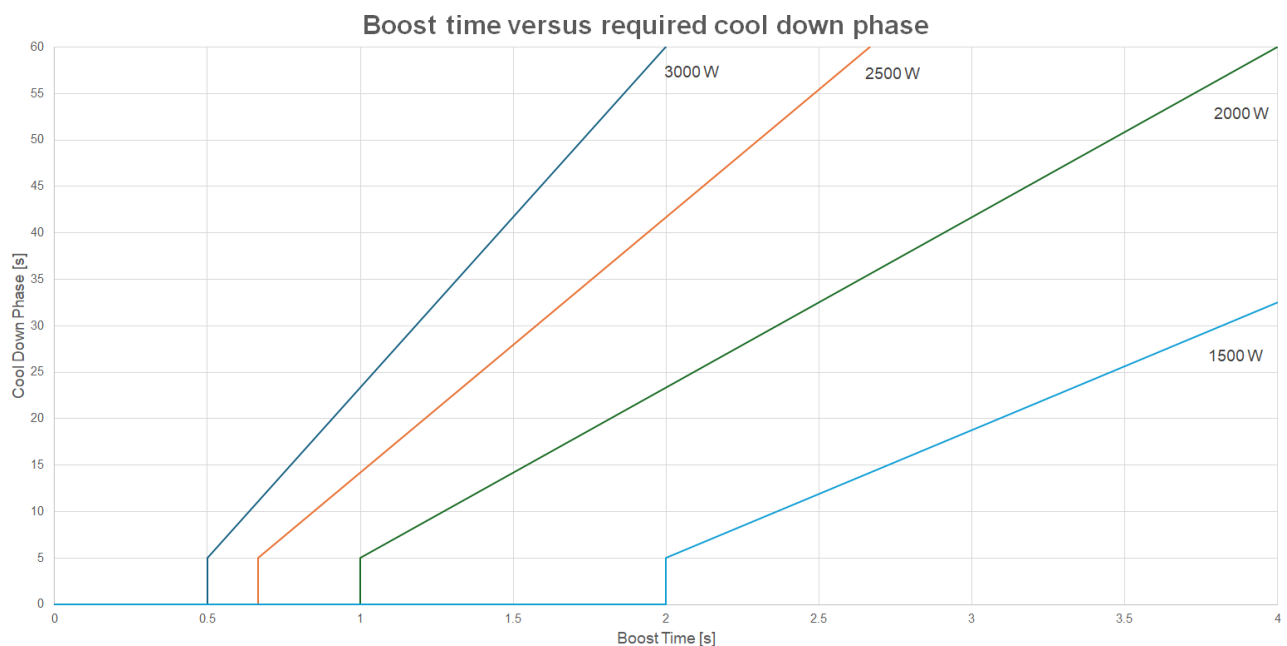

Figure 8-2: Boost time versus required cool down phase

Example 1: If the power supply delivers 1500 W during a total time of 2.0 seconds within a period of 4 seconds, no cool down phase is required.

Example 2: If the power supply delivers 1500 W during a total time of 2.5 seconds within a period of 4 seconds, the output power will be limited at 1000 W for 12 seconds.

Note: Due to tolerances, it is advisable to keep a reserve of 5%.

Note: For power supplies V1RB and lower, only the 3000 W boost curve is applicable. No different load states will be considered and the Figure 8-1 is not applicable.

9 Parallel Connection



Up to three power supplies can be connected in parallel. The power supply automatically detects the parallel connection. The connected wires must be adjusted to the maximal current. The connectors of the power supply are rated for 41 A. The power boost is not synchronized but still available.¹



¹ UL 61800-5-1 does not support parallel connection of power supplies. This function is not covered with the UL certification of the power supply.

10 Ordering Information

Item	Description	Item-No.
S02-72/1000	Power Supply 72 V/1000 W, 3x400-480 VAC	0150-4535

11 International Certificates

Europe 	See chapter 12 "Declaration of Conformity and CE-marking"
UK 	See chapter 13 UK Declaration of Conformity UKCA-Marking
<i>IECEE</i> <i>CB SCHEME</i>	Ref. Certif. No. CH-11541
USA / Canada 	All products marked with this symbol are tested and listed by Underwriters Laboratories and the production facilities are checked quarterly by an UL inspector. This mark is valid for the USA and Canada and eases certification of your machines and systems in these areas. File number E316095 UL 61800-5-1 Power Conversion Equipment CSA C22.2 Industrial Control Equipment

	<p>Ref. Certif. No.</p> <p>CH-11541</p>
<p>IEC SYSTEM FOR MUTUAL RECOGNITION OF TEST CERTIFICATES FOR ELECTRICAL EQUIPMENT (IECEE) CB SCHEME</p>	
<p>CB TEST CERTIFICATE</p>	
<p>Product</p> <p>Name and address of the applicant</p> <p>Name and address of the manufacturer</p> <p>Name and address of the factory</p> <p><i>Note: When more than one factory, please report on page 2</i></p> <p>Ratings and principal characteristics</p> <p>Trademark / Brand (if any)</p> <p>Customer Test Facility (CTF) Stage used</p> <p>Model / Type Ref.</p> <p>Additional information (if necessary may also be reported on page 2)</p> <p>A sample of the product was tested and found to be in conformity with</p> <p>As shown in the Test Report Ref. No. which forms part of this Certificate</p>	<p>Power Supply S02-72/1000</p> <p>NTI AG Bodenackerstrasse 2, 8957 Spreitenbach Switzerland</p> <p>NTI AG Bodenackerstrasse 2, 8957 Spreitenbach Switzerland</p> <p>NTI AG Bodenackerstrasse 2, 8957 Spreitenbach Switzerland</p> <p>U/I in: AC 3x400-480 V / 3.1 A, 50/60 Hz, Class I U/I out: 72 V / 13.9 A, 1000 W</p> <p>Linmot</p> <p>.</p> <p>S02-72/1000</p> <p>National Differences specified in the CB Test Report</p> <p>IEC 61000-3-2:2018 IEC 61000-3-2:2018/AMD1:2020 IEC 61000-3-3:2013 IEC 61000-3-3:2013/AMD1:2017 IEC 61000-6-2:2016 IEC 61000-6-4:2018 21CH-01109.E01</p>
<p>This CB Test Certificate is issued by the National Certification Body</p>	
 <p>Date: 2022-03-10</p>	<p>Eurofins Electric & Electronic Product Testing AG Luppenstrasse 3 8320 Fehraltorf SWITZERLAND</p> <p>Signature: Martin Plüss </p>

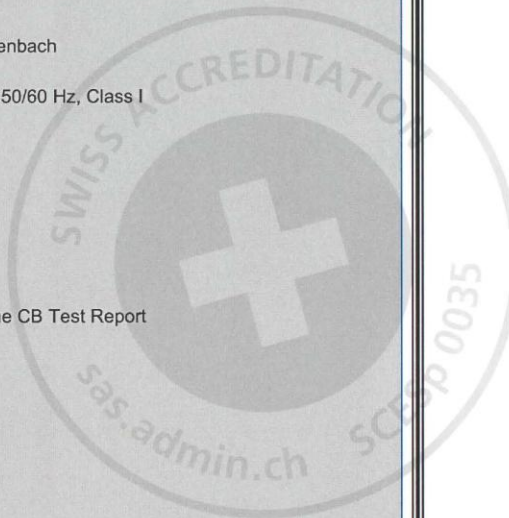

T01_V04

CERTIFICATE OF COMPLIANCE

Certificate Number UL-US-2205770-0
Report Reference E316095-20220222
Date 24-Feb-2022

Issued to: NTI AG
Bodenaeckerstr 2 SPREITENBACH 8957
Switzerland

This is to certify that representative samples of NMMS - Power Conversion Equipment
See Addendum Page for Product Designation(s).

Have been investigated by UL in accordance with the Standard(s) indicated on this Certificate.

Standard(s) for Safety: UL 61800-5-1, 1st Ed., Issue Date: 2012-06-08, Revision Date: 2021-02-11

Additional Information: See the UL Online Certifications Directory at <https://iq.ulprospector.com> for additional information

This Certificate of Compliance does not provide authorization to apply the UL Mark. Only the UL Follow-Up Services Procedure provides authorization to apply the UL Mark.

Only those products bearing the UL Mark should be considered as being UL Certified and covered under UL's Follow-Up Services.

Look for the UL Certification Mark on the product.

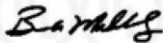

Bruce Mahrenholz, Director North American Certification Program

UL LLC

Any information and documentation involving UL Mark services are provided on behalf of UL LLC (UL) or any authorized licensee of UL. For questions, please contact a local UL Customer Service Representative at <http://ul.com/aboutul/locations/>



CERTIFICATE OF COMPLIANCE

Certificate Number UL-US-2205770-0
Report Reference E316095-20220222
Date 24-Feb-2022

This is to certify that representative samples of the product as specified on this certificate were tested according to the current UL requirements

Model	Category Description
S02-72/1000	Open Type, Power Conversion Equipment, Non-Isolated Power Supply

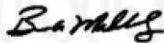

Bruce Mahrenholz, Director North American Certification Program

UL LLC

Any information and documentation involving UL Mark services are provided on behalf of UL LLC (UL) or any authorized licensee of UL. For questions, please contact a local UL Customer Service Representative at <http://ul.com/aboutul/locations/>



CERTIFICATE OF COMPLIANCE

Certificate Number UL-CA-2205785-0
Report Reference E316095-20220222
Date 24-Feb-2022

Issued to: NTI AG
Bodenaeckerstr 2 SPREITENBACH 8957
Switzerland

This is to certify that representative samples of NMMS7 - Power Conversion Equipment Certified for Canada
See Addendum Page for Product Designation(s).

Have been investigated by UL in accordance with the Standard(s) indicated on this Certificate.

Standard(s) for Safety: CSA C22.2 NO. 274, 2nd Ed., Issue Date: 2017-04-01, Revision Date: 2017-04-01

Additional Information: See the UL Online Certifications Directory at <https://iq.ulprospector.com> for additional information

This Certificate of Compliance does not provide authorization to apply the UL Mark. Only the UL Follow-Up Services Procedure provides authorization to apply the UL Mark.

Only those products bearing the UL Mark should be considered as being UL Certified and covered under UL's Follow-Up Services.

Look for the UL Certification Mark on the product.

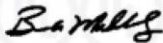

Bruce Mahrenholz, Director North American Certification Program

UL LLC

Any information and documentation involving UL Mark services are provided on behalf of UL LLC (UL) or any authorized licensee of UL. For questions, please contact a local UL Customer Service Representative at <http://ul.com/aboutul/locations/>



CERTIFICATE OF COMPLIANCE

Certificate Number UL-CA-2205785-0
Report Reference E316095-20220222
Date 24-Feb-2022

This is to certify that representative samples of the product as specified on this certificate were tested according to the current UL requirements

Model	Category Description
S02-72/1000	Open Type, Power Conversion Equipment, Non-Isolated Power Supply

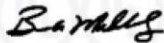

Bruce Mahrenholz, Director North American Certification Program

UL LLC

Any information and documentation involving UL Mark services are provided on behalf of UL LLC (UL) or any authorized licensee of UL. For questions, please contact a local UL Customer Service Representative at <http://ul.com/aboutul/locations/>



12 Declaration of Conformity and CE-marking

NTI AG / LinMot®
Bodenaeckerstrasse 2
8957 Spreitenbach
Switzerland
Tel.: +41 (0)56 419 91 91
Fax: +41 (0)56 419 91 92

declares under sole responsibility the compliance of the products:

Power supplies of the Series **S02-72/1000**

with the

Low Voltage Directive 2014/35/EU

Applied harmonized standard:

EN 61800-5-1: 2007

EMC Directive 2014/30/EU

Applied harmonized standards:

EN 61000-6-2: 2005 (Immunity for industrial environments)

EN 61000-6-4: 2007 + A1:2011 (Emission for industrial environments)

EN 61000-6-4: 2019

According to the EMC directive, the listed devices are not independently operable products.

Compliance of the directive requires the correct installation of the product, the observance of specific installation guides and product documentation. This was tested on specific system configurations.

The safety instructions of the manuals are to be considered.

The product must be mounted and used in strict accordance with the installation instructions contained within the installation guide, a copy of which may be obtained from NTI AG.

Company: NTI AG

Spreitenbach, 29.12.2021



Dr.-Ing. Ronald Rohner
CEO NTI AG



Dr.-Ing. Marco Hitz
RESPONSIBLE FOR DOCUMENTATION

13 UK Declaration of Conformity UKCA-Marking

NTI AG / LinMot®
Bodenaeckerstrasse 2
8957 Spreitenbach
Switzerland
Tel.: +41 (0)56 419 91 91
Fax: +41 (0)56 419 91 92

declares under sole responsibility the compliance of the products:

Power supplies of the Series **S02-72/1000**

with the

Electrical Equipment (Safety) Regulations 2016 SI 2016 No. 1101

Applied designated standards:

EN 61800-5-1: 2007

EMC Regulation S.I. 2016 No. 1091.

Applied designated standards:

EN 61000-6-2: 2005 (Immunity for industrial environments)

EN 61000-6-4: 2007 + A1:2011 (Emission for industrial environments)

EN 61000-6-4: 2019

According to the EMC regulation, the listed devices are not independently operable products.

Compliance of the regulation requires the correct installation of the product, the observance of specific installation guides and product documentation. This was tested on specific system configurations.

The safety instructions of the manuals are to be considered.

The product must be mounted and used in strict accordance with the installation instructions contained within the installation guide, a copy of which may be obtained from NTI AG.

Company: NTI AG Spreitenbach, 29.12.2021



Dr.-Ing. Ronald Rohner
CEO NTI AG



Dr.-Ing. Marco Hitz
RESPONSIBLE FOR DOCUMENTATION

ALL LINEAR MOTION FROM A SINGLE SOURCE

Europe / Asia Headquarters

NTI AG - LinMot & MagSpring

Bodenaeckerstrasse 2
CH-8957 Spreitenbach
Switzerland

Sales / Administration: +41 56 419 91 91
office@linmot.com

Tech. Support: +41 56 544 71 00
support@linmot.com

Web: <https://www.linmot.com/>

Visit <https://linmot.com/contact/> to find a distributor near you.

North / South America Headquarters

LinMot USA Inc.

N1922 State Road 120, Unit 1
Lake Geneva, WI 53147
USA

Sales / Administration: 262.743.2555
usasales@linmot.com

Tech. Support: 262.743.2555
usasupport@linmot.com

Web: <https://www.linmot-usa.com/>