

# Installation Guide

## Controller Series E100/E200/E400



**Products**

- E100-AT / -MT /-DN /-CO
- E200-AT / -MT /-DN/-CO
- E400-AT / -MT /-DN/-CO

**Content**

**IMPORTANT NOTES FOR E100/E200/E400 SERIES CONTROLLERS..... 2**

**SYSTEM OVERVIEW..... 3**

**E100 SERIES FUNCTION AND WIRING ..... 4**

**POWER SUPPLY AND GROUNDING ..... 5**

**DESCRIPTION OF THE CONNECTORS / INTERFACES ..... 6**

**POWER SUPPLY REQUIREMENT ..... 10**

**ORDERING INFORMATION ..... 10**

**DECLARATION OF CONFORMITY CE-MARKING ..... 11**

**ERROR CODES ..... 12**

**CONTACT ADDRESSES ..... 12**

**Important notes for E100/E200/E400 series controllers**

**CAUTION !!**



In order to assure a safe and error free operation, and to avoid severe damage to system components, all system components must be directly attached to a single ground bus that is earth or utility grounded.



Each system component should be tied directly to the ground bus (star pattern), rather than daisy chaining from component to component. (LinMot motors are properly grounded through their power cables when connected to LinMot controllers.)



All connectors must not be connected or disconnected while DC voltage is present. Do not disconnect system components until all LinMot controller LED's have turned off. (Capacitors in the power supply may not fully discharge for several minutes after input voltage been disconnected). Failure to observe these precautions may result in severe damage to electronic components in LinMot motors and/or controllers.



Do not switch Power Supply DC Voltage. All power supply switching and E-Stop breaks should be done to the AC supply voltage of the power supply.



Do not connect or disconnect the motors from controllers with voltage present. Wait to connect or disconnect motors until all LinMot controller LED's have turned off. (Capacitors may not fully discharge for several minutes after power has been turned off). Failure to observe these precautions may result in severe damage to electronic components in LinMot motors and/or controllers.

© 2010 NTI Ltd

This work is protected by copyright.

Under the copyright laws, this publication may not be reproduced or transmitted in any form, electronic or mechanical, including photocopying, recording, microfilm, storing in an information retrieval system, not even for didactical use, or translating, in whole or in part, without the prior written consent of NTI AG.

LinMot® is a registered trademark of NTI AG.

Note

The information in this documentation reflects the stage of development at the time of press and is therefore without obligation. NTI AG. reserves itself the right to make changes at any time and without notice to reflect further technical advance or product improvement.

**System Overview**

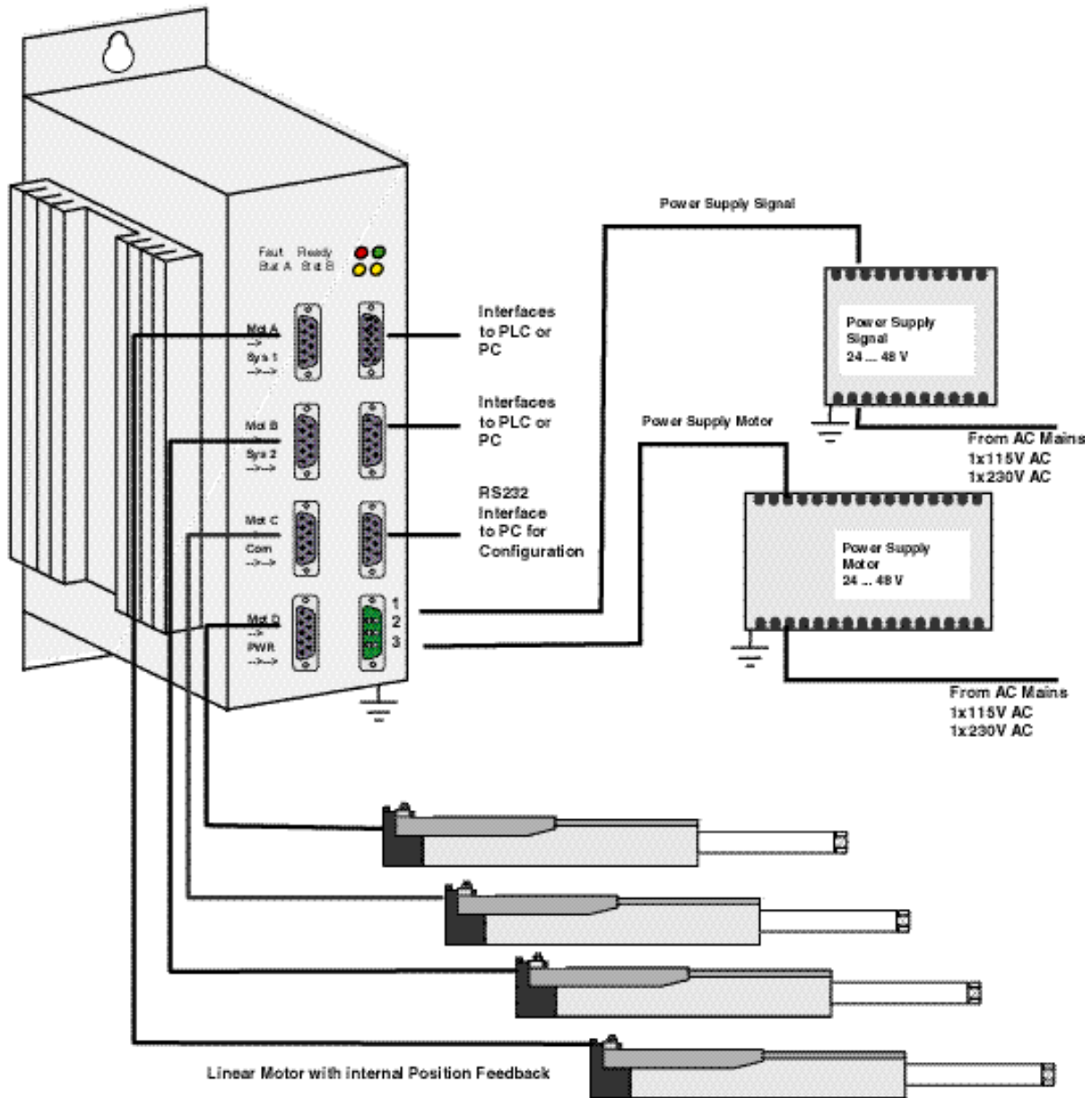

Complete E400 Controller based system (E100 and E200 controllers will only drive one respectively two motors). Power Supply for Signal and Motor may be the same device (see later).

**E100 series Function and Wiring**

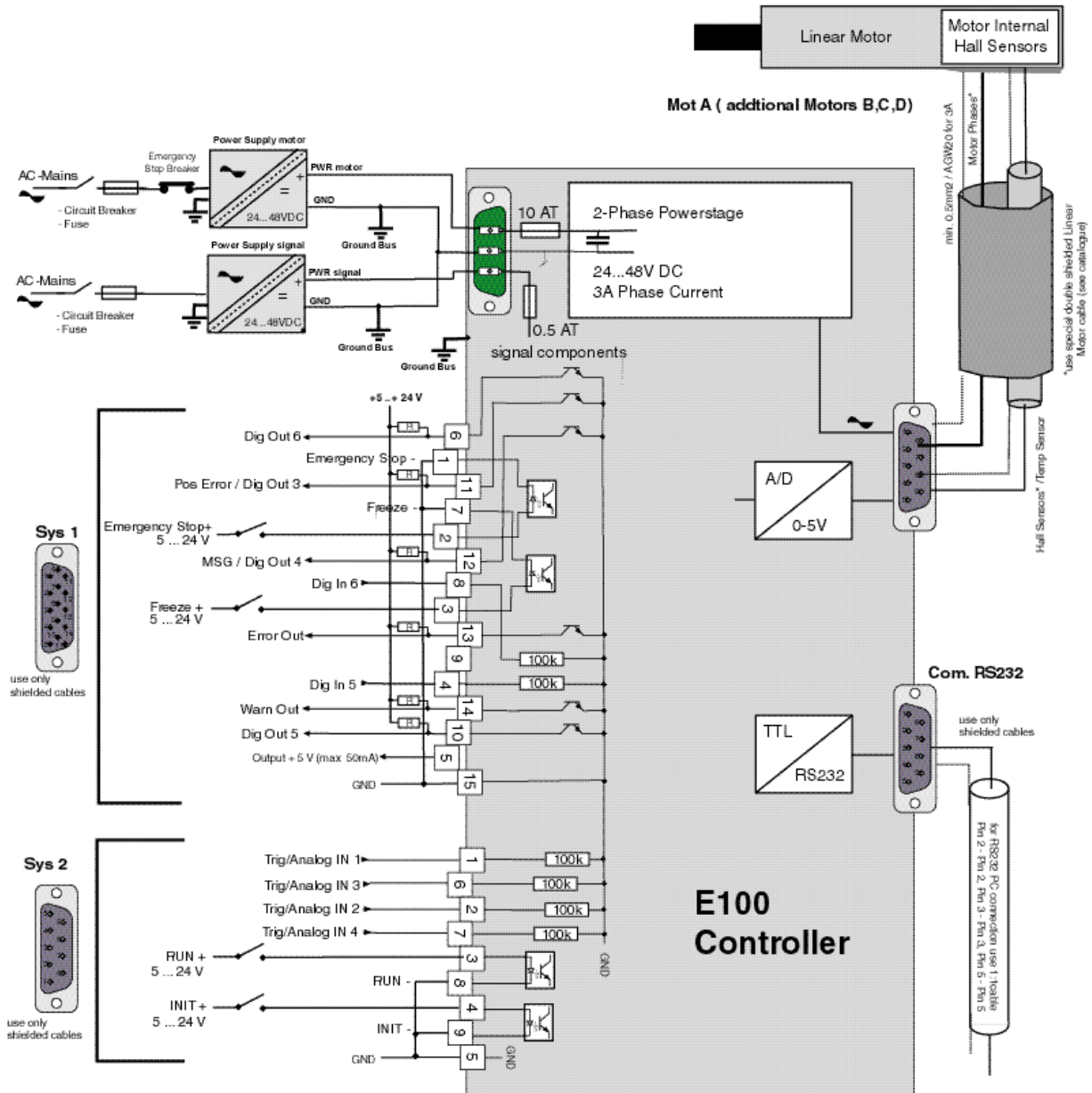

Typical wiring of a single axes controller. Multiple axes controller have additional motor connectors.

## Power Supply and Grounding

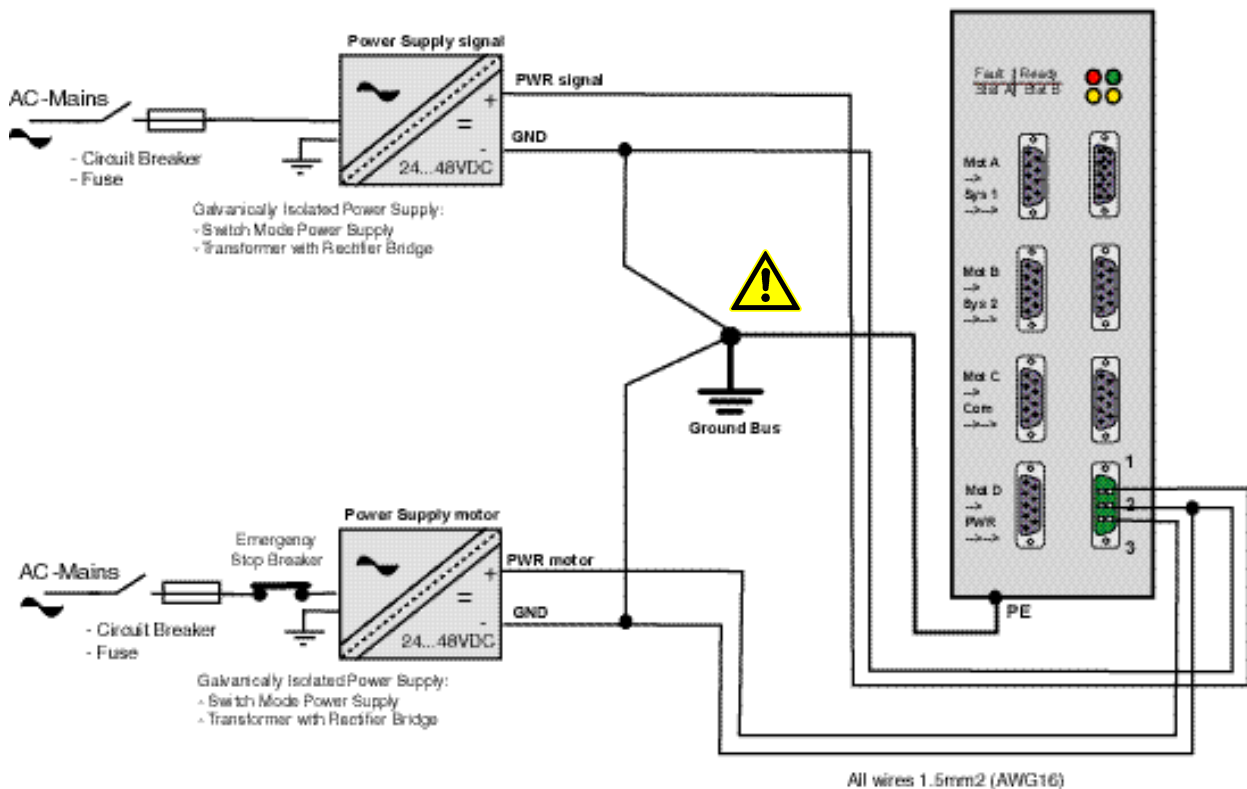

Instead of two separated power supplies it may be possible to use only one power supply if there is no need to control the signal power supply (logical devices of the controller) and the power supply of the powerstage for the motors independently (see safety rules of the application).



In order to assure a safe and error free operation, and to avoid severe damage to system components, **all system components must be well grounded to either a single earth or utility ground.** This includes both LinMot and all other control system components to the same ground bus.



Each system component should be tied directly to the ground bus (**star pattern**), rather than daisy chaining from component to component. (LinMot motors are properly grounded through their power cables when connected to LinMot controllers.)



**Power supply connectors must not be connected or disconnected while DC voltage is present.** Do not disconnect system components until all LinMot controller LED's have turned off. (Capacitors in the power supply may not fully discharge for several minutes after input voltage been disconnected). Failure to observe these precautions may result in severe damage to electronic components in LinMot motors and/or controllers.



**Do not switch Power Supply DC Voltage.** All power supply switching and E-Stop breaks should be done to the AC supply voltage of the power supply. Failure to observe these precautions may result in severe damage to controller.

## Description of the connectors / Interfaces

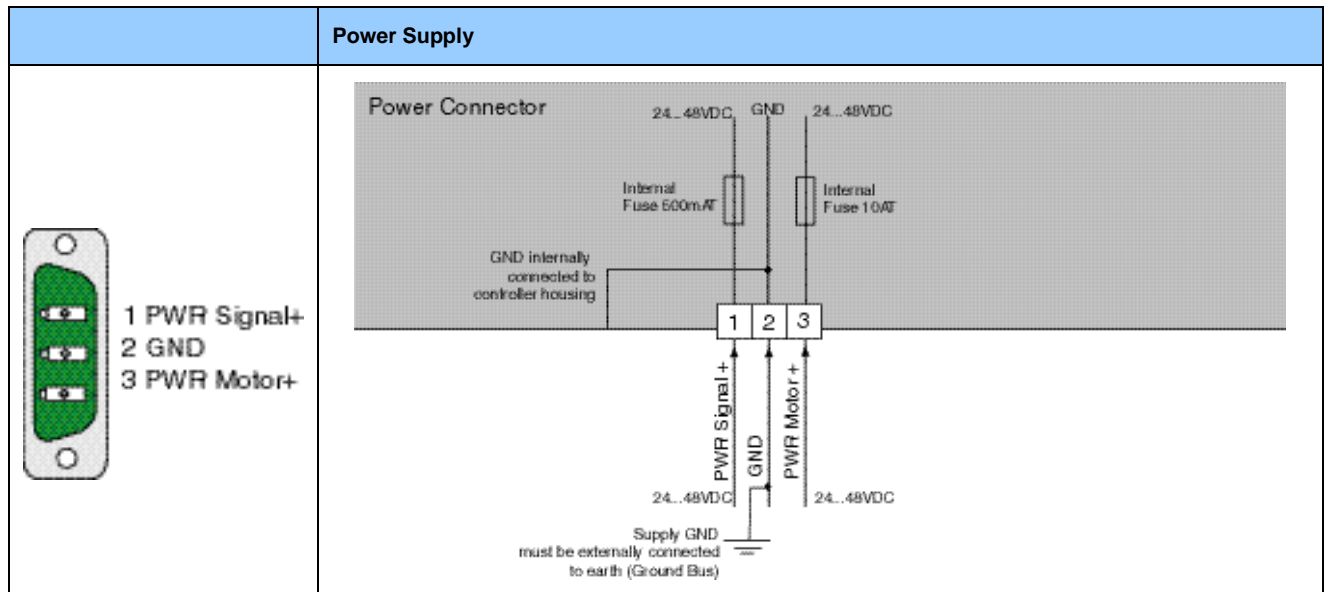

**Supply:**  
 Supply Voltage 24...48VDC. Absolute max. Rating 48VDC + 10%  
 Supply voltage for PWR Signal and PWR Motor may be different  
 Motor Supply GND must be externally connected to earth



**Caution:**  
 By exceeding 53VDC supply voltage, the controller will go into error state. Voltage higher than 55 VDC will damage the controller!  
 Do not switch Power Supply DC Voltage. All power supply switching and E-Stop breaks should be done to the AC supply voltage of the power supplies  
 Power supply connectors must not be connected or disconnected while DC voltage is present.

**Wiring:**  
 1.5 mm<sup>2</sup> (AWG16), max length 5 m

LED	State Display
-----	---------------



Ready Green	READY	The system has started correctly
Stat A Yellow	STAT A	Coding for the actual operating state
Stat B Yellow	STAT B	Coding for the actual operating state
		The display of the various operating states is shown on the last page of this manual..
Fault red	FAULT	An error has occurred (In the state ERROR a blink code of the STAT LEDs A and B tells what the actual error is. The blink codes are explained in chapter 'Service' of the user Manual.)



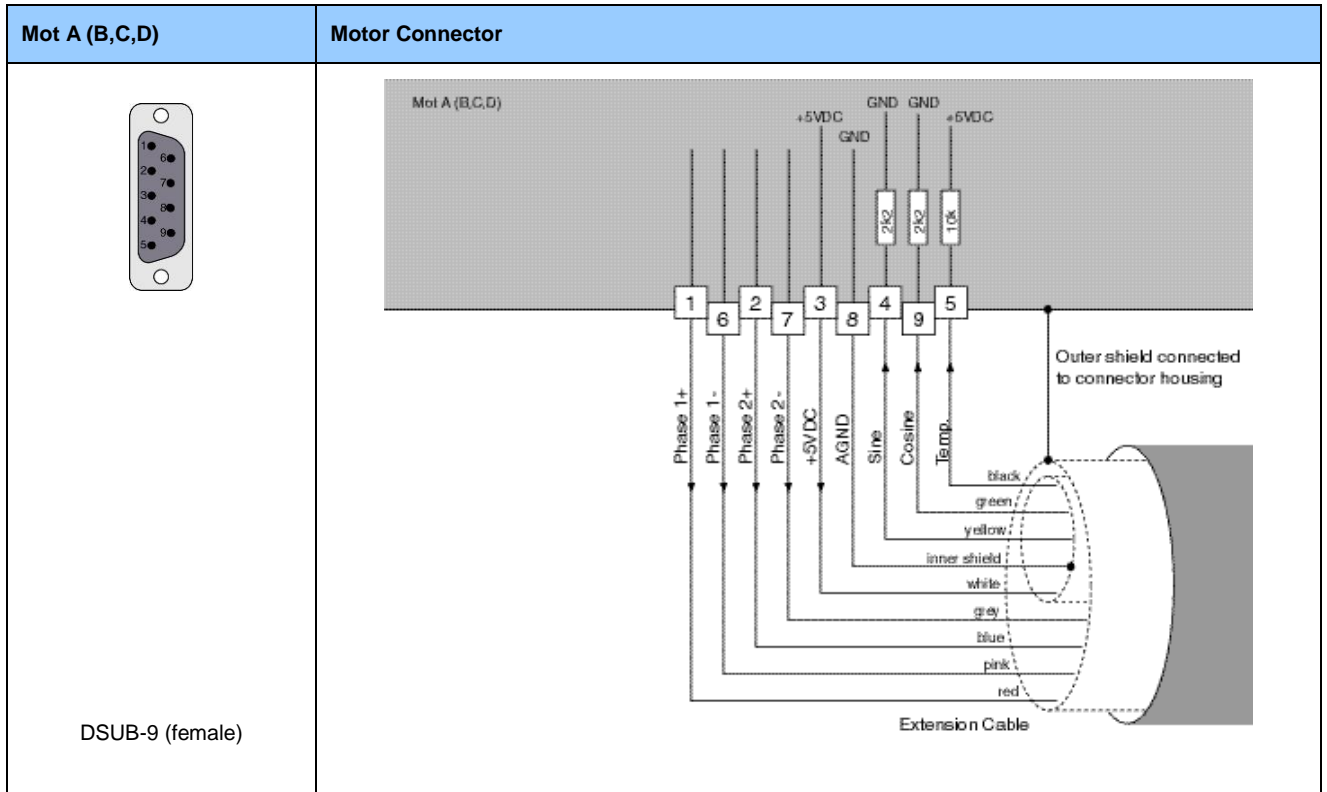

**Note:**

- Use only special double-shielded Linear Motor Cable (see datasheet 'extension cables')
- Use +5V (Pin 3) and AGND (Pin 8) only for motor internal Hall Sensor supply (max. 100mA).
- Do NOT connect AGND (Pin 8) to ground or earth!
- Inner shield (AGND) and outer shield (earth) must be isolated to each other.



**Caution:**

- Wrong Motor wiring may damage Linear Motors and/or Servo Controller.
- If you are assembling motor cables by your own, double check motor wiring carefully before power up.



**Do not connect or disconnect the motors from controllers with voltage present.** Wait to connect or disconnect motors until all LinMot controller LED's have turned off. (Capacitors may not fully discharge for several minutes after power has been turned off). Failure to observe these precautions may result in severe damage to electronic components in LinMot motors and/or controllers.

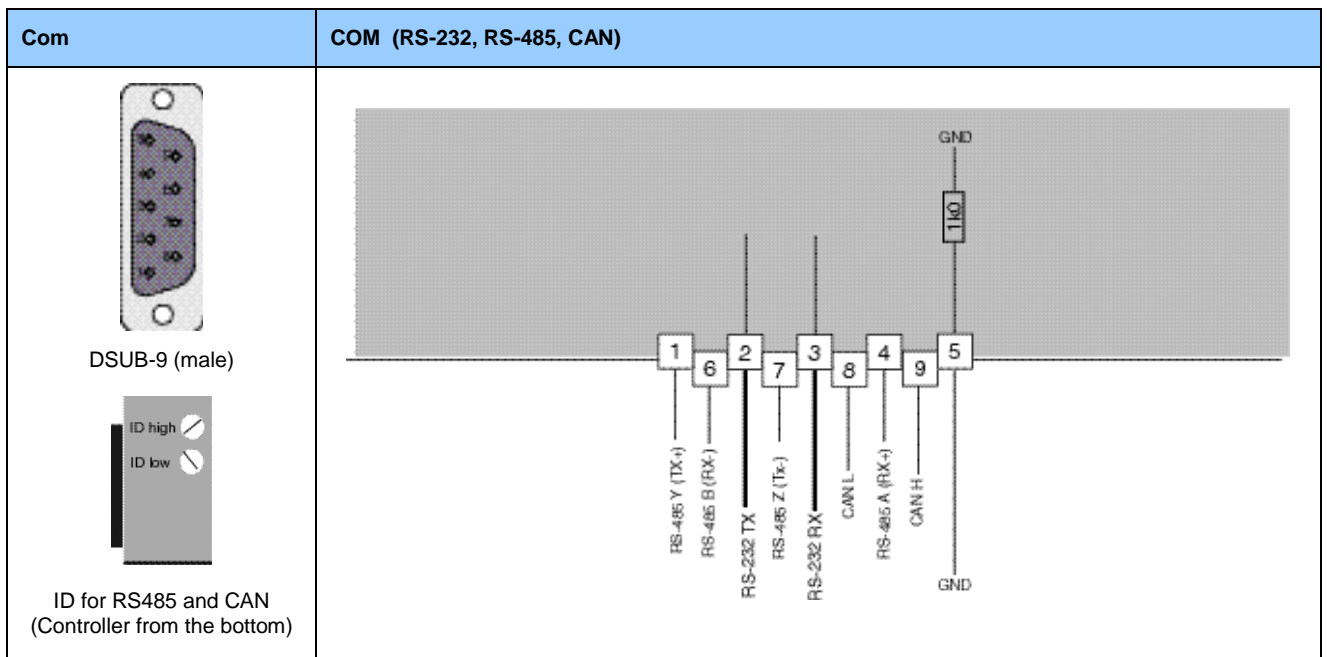

RS232: 9.6kBaud, use 1:1 connection cable to PC  
 RS485 and CAN needs external termination (see manual)

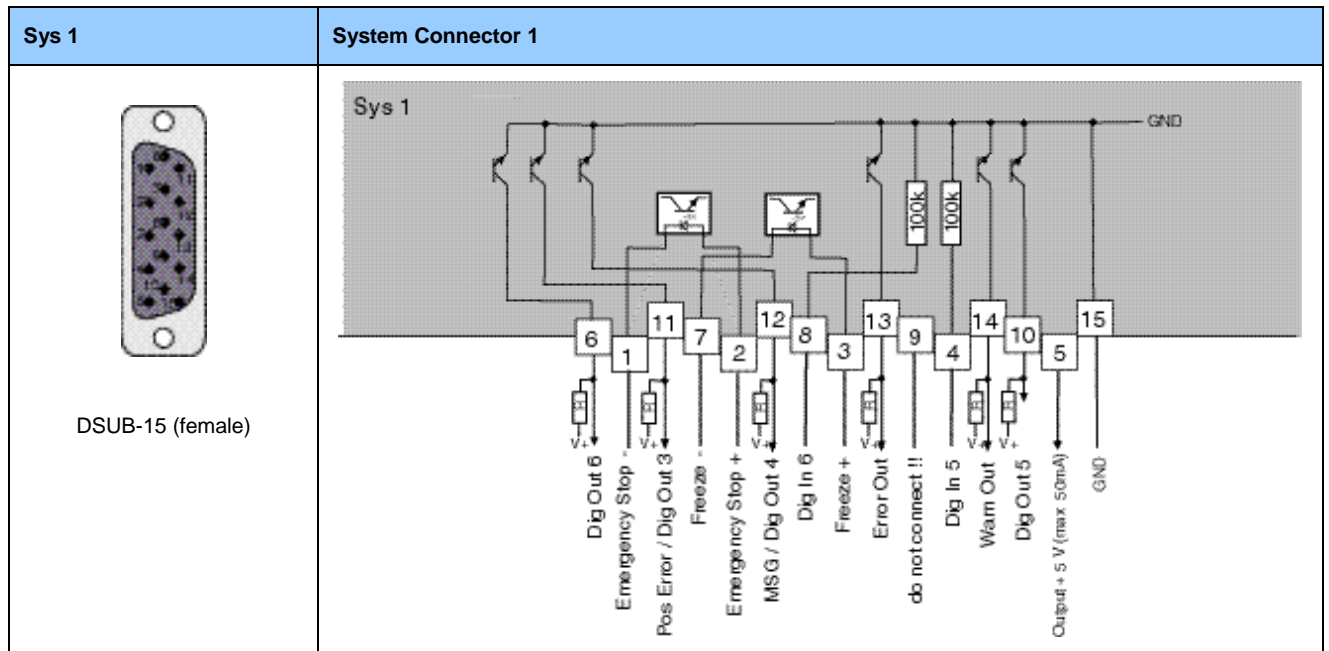

**Emergency Stop (active low) / Freeze input (active high)**

Optical isolated inputs  
 Input voltage: 0 ... 24V  
                   for logical zero < 2V  
                   for logical one > 3.5V  
 Input current: < 20 mA (internally limited to 20 mA)  
 Update rate: 1.6 ms

**Dig In 5 / Dig In 6**

max. 24V, input resistance 100kOhm for logical zero < 2V for logical one > 3.5V

**Dig Outputs: Dig Out 6, Pos Error Out, MSG, Error Out, Warn Out, Dig Out 5**

Open Collector max 24V / 50 mA)

Typical pull-up Resistor R: for V+ = 5V supply: R= 150 Ohm / 0.25 W  
 For V+ = 24V supply: R=820 Ohm / 1W

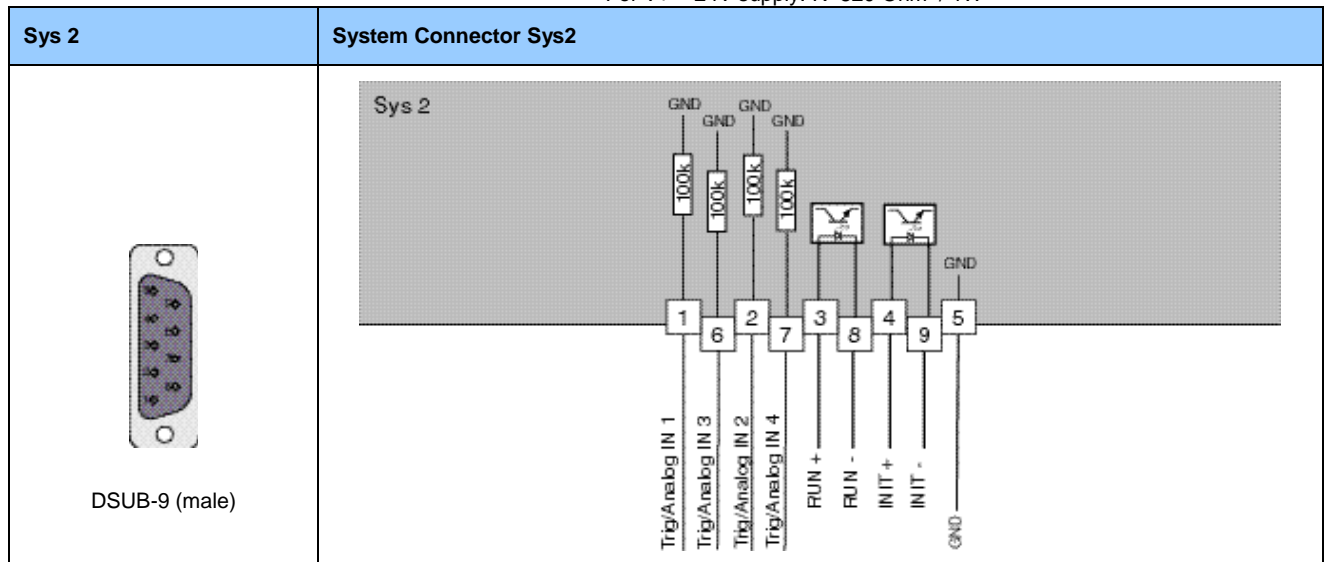

**Trig/Analog IN**

Input can be used as analog inputs between 0 ... 10V (10 bit resolution) input resistance 100kOhm or digital inputs (max. 24V, input resistance 100kOhm) for logical zero < 2V for logical one > 3.5V

**RUN (active high) / INIT (active high)**

Optical isolated inputs  
 Input voltage: 0 ... 24V  
                   for logical zero < 2V  
                   for logical one > 3.5V  
 Input current: < 20 mA (internally limited to 20 mA)  
 Update rate: 1.6 ms



**Mechanical Dimension**

Dimensions

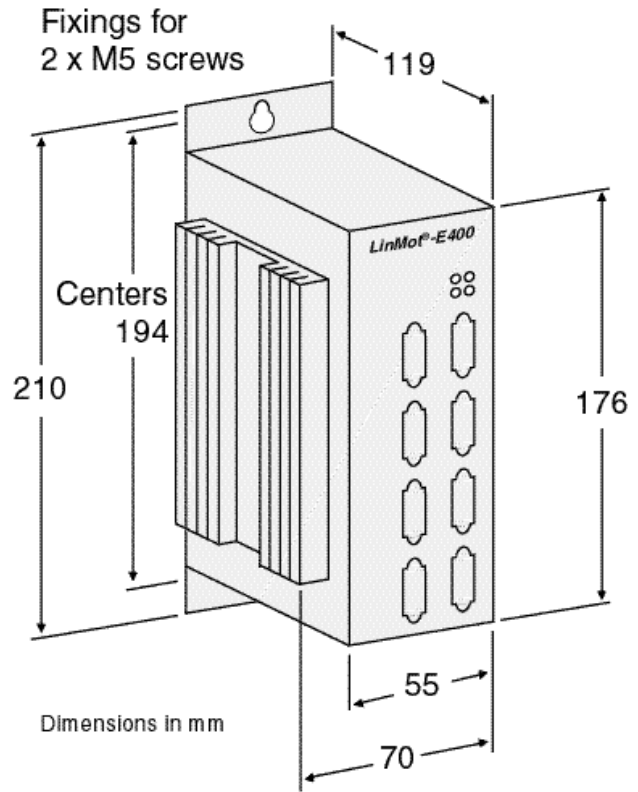

**Recommended mounting for multiple controller installation**

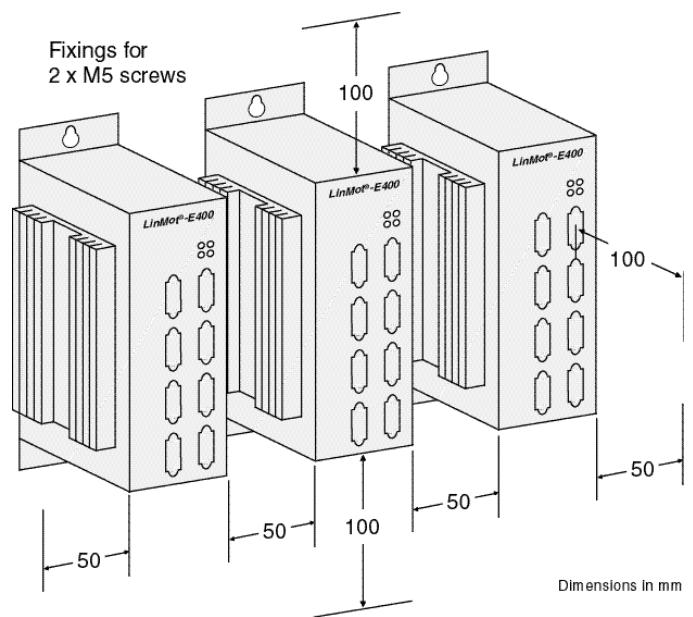

		<b>E100</b> <i>Single axes controller</i>	<b>E200</b> <i>2 axes controller</i>	<b>E400</b> <i>4 axes controller</i>
Width	mm (in)	70 (2.8)		
Height	mm (in)	210 (8.3)		
Height without fixings	mm (in)	176 (6.9)		
Depth	mm (in)	119 (4.7)		
Weight	Kg (lb)	1.1 (2.4)	1.2 (2.7)	1.3 (2.9)
Case	IP	40		
Storage Temperature	°C	-25...70		
Operating Temperature	°C	0...50		
Max. Case Temperature	°C	65		

## Power Supply Requirement

### Power Supply motor

The calculation of the needed power for the Motor supply is depending on the application and the used motor(s). The following table shows a recommendation for general applications.

Controller		Voltage/ Power	LinMot Switched- Power Supply	Part-Nr.
E100	1 motor	48 V / 150 W	S01-48/150	0150-1940
E200	Up to 2 motors	48 V / 300 W	S01-48/300	0150-1941
E400	Up to 4 motors	48 V / 300 W	S01-48/300	0150-1941

### Power Supply signal

24 ... 48 V / 5 W

### Regeneration of Power

The Ex00 controller don't use a regeneration resistor. In most application the recuperated energy will not become an issue. In cases where the motor power supply voltage will exceeds the voltage limits because of recuperation an additional capacitor between 'PWR motor' and 'GND' should be used. Typical: 22'000 uF.

## Ordering Information

Servo Controller	Description	Art. No.
E100-AT	Analog Trigger Controller 1 Axis (48V/3A)	0150-1601
E100-MT	Multi Trigger Controller 1 Axis (48V/3A)	0150-1611
E100-DN	DeviceNet Controller 1 Axis (48V/3A)	0150-1641
E100-CO	CanOpen Controller 1 Axis (48V/3A)	0150-1669
E200-AT	Analog Trigger Controller 2 Axis (48V/3A)	0150-1602
E200-MT	Multi Trigger Controller 2 Axis (48V/3A)	0150-1612
E200-DN	DeviceNet Controller 2 Axis (48V/3A)	0150-1642
E200-CO	CanOpen Controller 2 Axis (48V/3A)	0150-1670
E400-AT	Analog Trigger Controller 4 Axis (48V/3A)	0150-1604
E400-MT	Multi Trigger Controller 4 Axis (48V/3A)	0150-1614
E400-DN	DeviceNet Controller 4 Axis (48V/3A)	0150-1644
E400-CO	CanOpen Controller 4 Axis (48V/3A)	0150-1672

**Declaration of Conformity CE-Marking**

Manufacturer: NTI AG  
 LinMot®  
 Technoparkstrasse 1  
 8005 Zurich  
 Switzerland  
 Tel.: +41 (0) 1 445 22 82  
 Fax: +41 (0) 1 445 22 81

Products: LinMot® Controllers

Type	Art.-No.	Type	Art.-No.	Type	Art.-No.
E100-AT	0150-1601	E100-MT	0150-1611		
E200-AT	0150-1602	E200-MT	0150-1612		
E400-AT	0150-1604	E400-MT	0150-1614		
E100-DN	0150-1641	E100-CO	0150-1669		
E200-DN	0150-1642	E200-CO	0150-1670		
E400-DN	0150-1644	E400-CO	0150-1672		

The product must be mounted and used in strict accordance with the installation instruction contained within the User's Manual, a copy of which may be obtained from NTI Ltd.

I declare that as the authorized representative, the above information in relation to the supply/manufacture of this product is in conformity with the stated standards and other related documents in compliance with the protection requirements of the Electromagnetic Compatibility (EMC) Directive 2004/108/EC.

Standards Complied with:

EMI	EN 55011	Class A
EN 61000-6-4		
Electromagnetic	EN 61000-4-2	4 kV / 8kV
Suspectibility EMC	EN 61000-4-4	1 kV / 2kV
EN 61000-6-2	EN 61000-4-3	10 V/m
	EN 61000-4-6	10 V
	ENV 50204	10 V/m

Company  
 NTI Ltd.

Spreitenbach, July 28, 2010



-----  
 R. Rohner / CEO NTI AG

## Error codes

**Error display:** When an error occurs, it is displayed by means of the blinking of at least one of the four LEDs on the front of the servo controller.

**Ready LED:** The Ready LED is ON as soon as the supply voltage for the processor is guaranteed and the system has started up correctly. Communication with the PC over the serial interface is only possible when this LED is ON.

The following table summarizes the blink codes and their meaning:

LED			Description
Fault	Stat A	Stat B	
● ~ 3Hz	off	off	HW system error: Hardware error in the servo controller.
2x ● ~ 1Hz			SW1 System error: Software error in the servo controller. The system software wasn't loaded successfully.
● ~ 1Hz			SW2 System error: Software error in the servo controller. The system software wasn't loaded successfully.
On	● ~ 2Hz	● ~ 2Hz	Generic fault: The exact error message may be displayed with the error inspector.
On	■	2x ●	The supply voltage for the Power circuitry is too low.
		3x ●	The supply voltage for the Power circuitry is too high.
		4x ●	The supply voltage for the Signal circuitry is too low.
		5x ●	The supply voltage for the Signal circuitry is too high.
		6x ●	The servo controller is too hot.
		8x ●	Application Software Error (see manual)
	1x ●: Mot A	1x ●	The motor is overloaded.
	2x ●: Mot B	2x ●	The motor is too hot.
	3x ●: Mot C	3x ●	Following error.
	4x ●: Mot D	4x ●	The slider is missing from the motor.
		6x ●	The initialization was not successfully completed.
		7x ●	Incorrect motor type configured or damaged motor.
		8x ●	A referenced motion profile for a motor is missing. Selected motion profile not valid for actual drive type.

On: LED is ON  
Off: LED is OFF

● LED blinks shortly (ca. ¼s)  
■ LED blinks longer (ca. 1½s)

## Contact Addresses

### NTI AG

LinMot  
Bodenaeckerstrasse 2  
CH-8957 Spreitenbach  
Schweiz

Sales: +41 (0)56-419 91 91  
office@linmot.com  
Tech Support: +41-(0)56-544 71 00  
support@linmot.com  
http://www.linmot.com/support  
skype:support.linmot  
Fax: +41 (0)56-419 91 92  
Web: www.linmot.com

### LinMot Inc.

204 E Morrissey Dr.  
Elkhorn  
WI 53121  
USA

Sales: 877-546-3270  
262-743-2555  
Tech. Service: 877-804-0718  
262-743-1284  
Fax: 800-463-8708  
262-723-6688  
E-Mail: sales@linmot-usa.com  
Web: www.linmot-usa.com