

LinMot® Linear Rotary Motors

Version 3.11

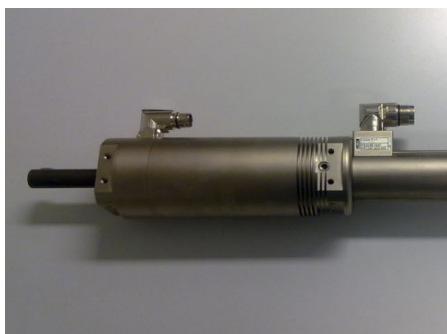

CAUTION

LINMOT SLIDERS CONTAIN NEODYMIUM MAGNETS WHICH MAY DISTURB OR DAMAGE MAGNETIC DATA CARRIERS AND DELICATE ELECTRONIC EQUIPMENT MERELY BY COMING CLOSE TO THEM.



WHEN HANDLING SLIDERS BE AWARE THAT, DUE THE STRONG MAGNETIC ATTRACTION, INJURY FROM FINGERS BEING PINCHED BETWEEN THE SLIDER AND NEARBY STEEL ITEMS IS A VERY REAL POSSIBILITY IF CAUTION IS NOT EXERCISED.



THE SLIDERS OF LINMOT® MOTORS CAN REACH TEMPERATURES WHICH MAY CAUSE BURNS UPON BEING TOUCHED.



THE SLIDERS AND SHAFTS OF LINMOT® LINEAR ROTARY MOTORS ARE FAST-MOVING MACHINE ITEMS. THE USER MUST TAKE ALL NECESSARY PRECAUTIONS TO PREVENT THEIR BEING TOUCHED (PROVIDE COVERS, PROTECTION AGAINST TOUCHING ETC.).



DO NOT RUN INTO THE INTERNAL MECHANICAL END STOPS.



Linear Rotary Motors PR01-52 and PR01-84

Index of Contents

OVERVIEW	7
LinMot PR01 Linear Rotary Motors.....	7
Variants model PR01-52.....	8
Variants model PR01-52 with planetary gear.....	8
Variants model PR01-84.....	8
Variants model PR01-84 in 'Stainless Steel'.....	8
Variants model PR01-84 with planetary gear.....	8
TECHNICAL DATA MODEL PR01-52	9
TECHNICAL DATA MODEL PR01-52 WITH PLANETARY GEAR	11
TECHNICAL DATA MODEL PR01-84	13
TECHNICAL DATA MODEL PR01-84 WITH PLANETARY GEAR	15
TORQUE-SPEED CURVE ROTARY MOTORS	17
STARTUP	18
Drive settings.....	18
Configuration Linear Motor.....	19
Configuration Rotary Motor.....	19
Homing the Rotary Motor.....	20
Homing the Linear Motor.....	20
Example of VAI motion with Rotary Motor.....	20
Example of motion using a VAI motion command.....	21
Notes on operating the Linear Rotary Motor.....	23
Running in the mechanical end stop may damage the motor.....	23
Strategy for the linear and rotating movement.....	23
LINEAR ROTARY MOTORS WITH PLANETARY GEAR	24
Model PR01-52 with planetary gear.....	24
Model PR01-84 with planetary gear.....	24
STAINLESS STEEL VARIANT OF THE PR01-84X80-SSC SERIES	25
Notes on application of the PR01-84x80-SSC series.....	26
Notes on cleaning the SSC variants.....	26
Special Application.....	27
Example: Linear Rotary Motors on a turntable.....	27
Cam profile for E-stop in applications with rotary disk.....	28
INSTALLING LINEAR ROTARY MOTORS	29
DRAWINGS OF LINEAR ROTARY MOTORS WITH ACCESSORIES	31
CAD-Files.....	33
ACCESSORIES	34
Heat sinks for linear motors.....	34
Heat sinks combinations for linear motors.....	34
Mounting and cooling flange for linear motors.....	35
Fan Kits.....	36
Fan Kits for Linear Motor.....	36
Fan Kit for Rotary Motors.....	37
Wipers.....	38
Multifunction flange and MagSpring.....	39
Mounting/Orientation of the accessories.....	39
Direction force of the MagSpring.....	40
Overview MagSpring UNO.....	41
Overview MagSpring DUO.....	42
Overview MagSpring SYM.....	43

Overview Brake-Kit.....	44
Mounting instructions: Pos. 2.1, 2.2 and 2.3 must be secured with a thread locker.....	44
Order information: one Item of Position 1 and 2 must be ordered.....	44
Flanges dimensions.....	45
Adapters dimensions.....	46
Cam Kit MF01-PK84.....	47
Dimensions Cam flange.....	48
Dimensions Cam adapter.....	48
MagSpring Cover (only for model PR01-84 with 300 mm stroke).....	49
Magnetic spring MagSpring®.....	50
Accessories Overview.....	51
Order examples.....	53
Load attachment.....	55
CONNECTOR ASSIGNMENT.....	56
Connector assignment Linear Motors.....	56
Connector assignment Rotary Motors.....	56
DRAWINGS.....	57
Drawing PR01-52x40-R/37x120F-HP-C-80.....	57
Stroke range PR01-52x40-R/37x120F-HP-C-80.....	58
Drawing PR01-52x60-R/37x120F-HP-C-100.....	59
Stroke range PR01-52x60-R/37x120F-HP-C-100.....	60
Drawing PR01-52x60-R/37x120F-HP-C-100 with Flange PF02-37x100.....	61
Drawing PR01-52x60-R/37x120F-HP-C-100 with MagSpring.....	62
Drawing PR01-52x60-R/37x120F-HP-C-100 Flange/MagSpring/Fan.....	63
Drawing PR01-52x60-R/37x120F-HP-C-150.....	64
Stroke range PR01-52x60-R/37x120F-HP-C-150.....	65
Drawing PR01-52x60-R/37x120F-HP-C-100-G.....	66
Stroke range PR01-52x60-R/37x120F-HP-C-100-G.....	67
Drawing PR01-84x80-C/48x240F-C-100.....	68
Stroke range PR01-84x80-C/48x240F-C-100.....	69
Drawing PR01-84x80-C/48x240F-C-100 MagSpring.....	70
Drawing PR01-84x80-C/48x240F-C-100 with Flange and MagSpring.....	71
Drawing PR01-84x80-C/48x360F-C-100.....	72
Stroke range PR01-84x80-C/48x360F-C-100.....	73
Drawing PR01-84x80-C/48x240F-C-150.....	74
Stroke range PR01-84x80-C/48x240F-C-150.....	75
Drawing PR01-84x80-C/48x360F-C-150.....	76
Stroke range PR01-84x80-C/48x360F-C-150.....	77
Drawing PR01-84x80-SSC-C/48x240F-C-150.....	78
Stroke range PR01-84x80-SSC-C/48x240F-C-150.....	79
Drawing PR01-84x80-SSC-C/48x360F-C-150.....	80
Stroke range PR01-84x80-SSC-C/48x360F-C-150.....	81
Drawing PR01-84x80-C / RS01-84x80-SSC-C / 48x240F-C-300.....	82
Stroke range PR01-84x80-C / RS01-84x80-SSC-C / 48x240F-C-300.....	83
Drawing PR01-84x80-C/48x240F-C-150-G.....	84
Stroke Range PR01-84x80-C/48x240F-C-150-G.....	85
Drawing PR01-84x80-C/48x360F-C-150-G.....	86
Stroke Range PR01-84x80-C/48x360F-C-150-G.....	87
MAINTENANCE OF LINMOT® LINEAR ROTARY MOTORS.....	88
Inspection.....	88
Cleaning and lubrication.....	88

Disassembling and cleaning.....	88
Lubrication and assembling.....	89
Lubricant.....	89
Cleaning Agent.....	89
Storage / transport.....	89
TROUBLE SHOOTING.....	90
Trouble Shooting of Linear Motors.....	90
Trouble Shooting of Rotary Motors.....	91
CAUTION: HANDLING INSTRUCTIONS FOR SLIDERS.....	92
DECLARATION OF CONFORMITY AND CE-MARKING.....	93
CB TEST CERTIFICATE.....	94
CONTACT ADDRESS:.....	95

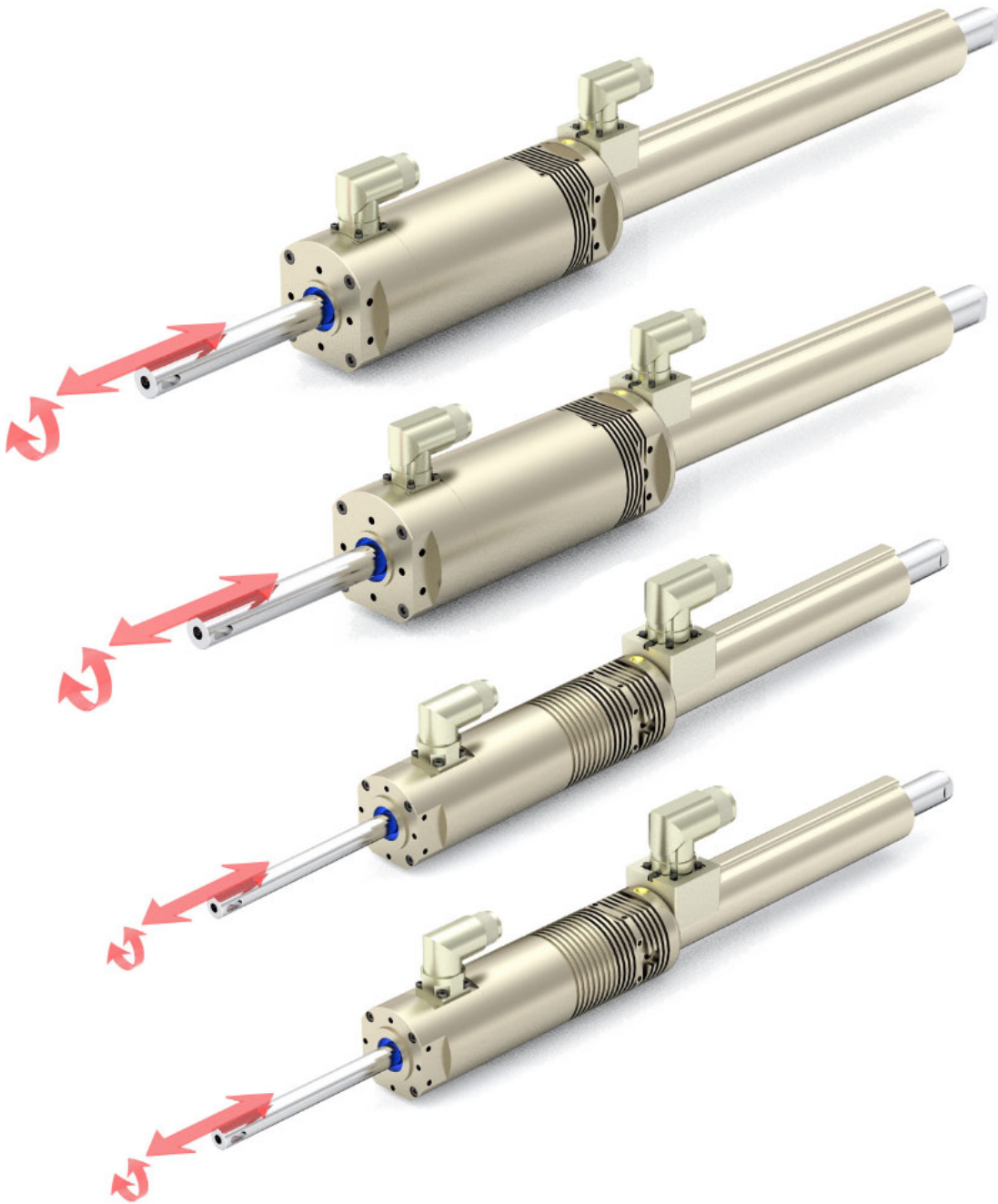

Figure: Linear Rotary Motors series PR01-52 and PR01-84

Overview

LinMot PR01 Linear Rotary Motors

The LinMot PR01 series of Linear Rotary Motors includes various sizes that differ primarily in the maximum torque available from the rotary motor or the linear force available from the linear motor. In addition to the different sizes, variants with axial through-holes (for a pneumatic line or an ejector, for example) and Stainless Steel models are available.

A Linear Rotary Motor fundamentally consists of a linear motor with an attached rotary torque motor. The two motors are electrically independent units and can be controlled completely independently of each other.

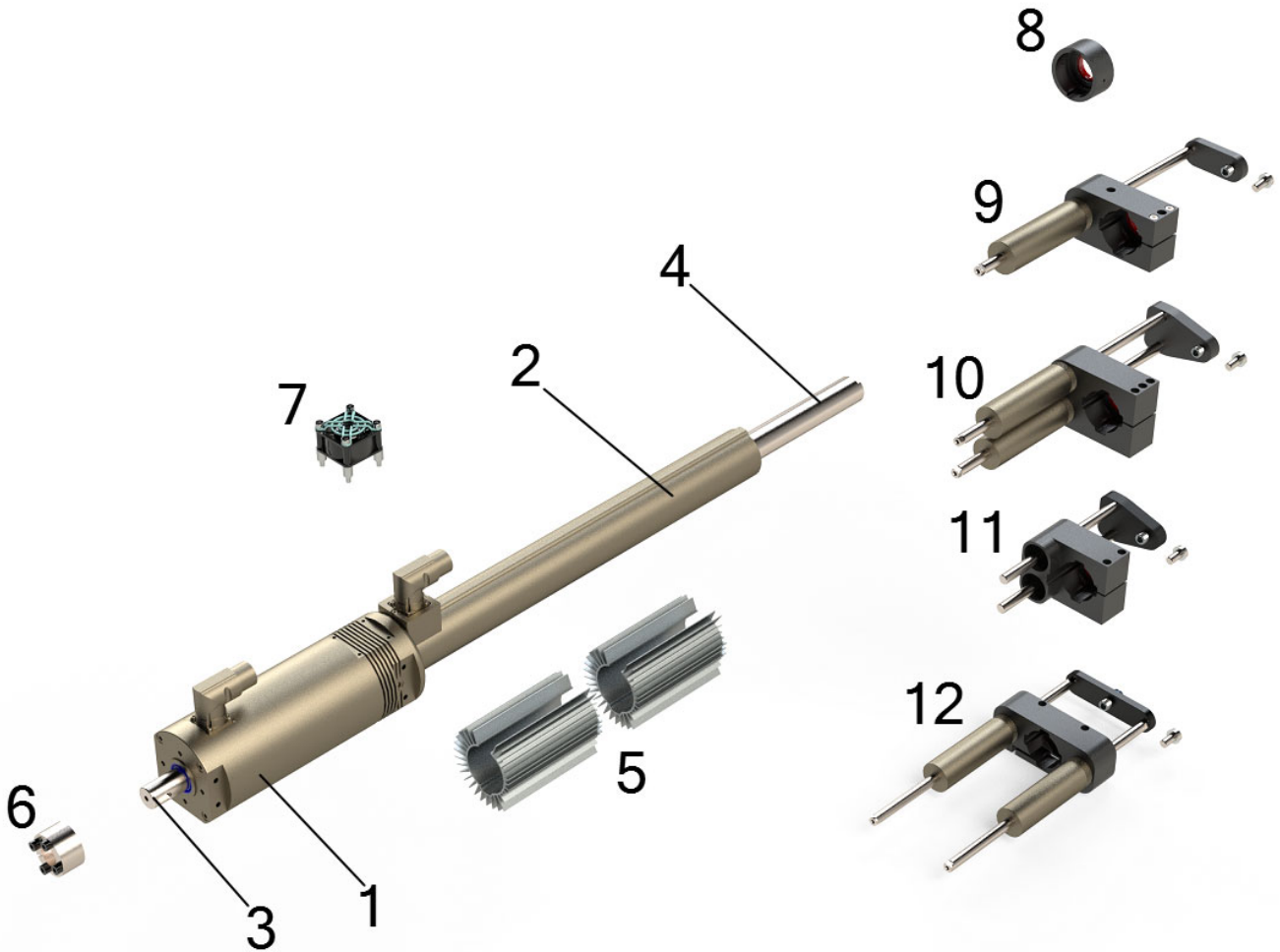

1. Rotary Motor
2. Linear Motor
3. Shaft (moves linear and rotating)
4. Slider of the Linear Motor (moves linear)
5. Option: Heat sinks for Linear Motor
6. Option: Clamp Set for load attachment
7. Option: Fan Kit for Rotary Motor
8. Option: Wiper
9. Option: MagSpring Kit UNO
10. Option: MagSpring Kit DUO
11. Option: Cam Kit
12. Option: MagSpring Kit SYM

More combinations available

Variants model PR01-52

PR01-52x40-R/37x120F-HP-C-80	(solid shaft)	Item No.: 0150-1573
PR01-52x40-R/37x120F-HP-C-80-L	(hollow Shaft)	Item No.: 0150-2703
PR01-52x60-R/37x120F-HP-C-100	(solid shaft)	Item No.: 0150-1197
PR01-52x60-R/37x120F-HP-C-100-L	(hollow Shaft)	Item No.: 0150-2704
PR01-52x60-R/37x120F-HP-C-150	(solid shaft)	Item No.: 0150-2705
PR01-52x60-R/37x120F-HP-C-150-L	(hollow Shaft)	Item No.: 0150-2706

Variants model PR01-52 with planetary gear

PR01-52x60-R/37x120F-HP-C-100-G05 gearbox 5:1	Item No.: 0150-2648
PR01-52x60-R/37x120F-HP-C-100-G10 gearbox 10:1	Item No.: 0150-2647

Variants model PR01-84

PR01-84x80-C/48x240F-C-100	(solid shaft)	Item No.: 0150-1194
PR01-84x80-C/48x240F-C-100-L	(hollow Shaft)	Item No.: 0150-1196
PR01-84x80-C/48x360F-C-100	(solid shaft)	Item No.: 0150-1199
PR01-84x80-C/48x360F-C-100-L	(hollow Shaft)	Item No.: 0150-1200
PR01-84x80-C/48x240F-C-150	(solid shaft)	Item No.: 0150-1187
PR01-84x80-C/48x240F-C-150-L	(hollow Shaft)	Item No.: 0150-1188
PR01-84x80-C/48x360F-C-150	(solid shaft)	Item No.: 0150-1168
PR01-84x80-C/48x360F-C-150-L	(hollow Shaft)	Item No.: 0150-1166
PR01-84x80-C/48x240F-C-300	(solid shaft)	Item No.: 0150-1580
PR01-84x80-C/48x240F-C-300-L	(hollow Shaft)	Item No.: 0150-2554

Variants model PR01-84 in 'Stainless Steel'

PR01-84x80-SSC-C/48x240F-C-150	(solid shaft, Stainless Steel)	Item No.: 0150-1581
PR01-84x80-SSC-C/48x240F-C-150-L	(hollow Shaft , Stainless Steel)	Item No.: 0150-1582
PR01-84x80-SSC-C/48x360F-C-150	(solid shaft, Stainless Steel)	Item No.: 0150-1579
PR01-84x80-SSC-C/48x360F-C-150-L	(hollow Shaft Stainless Steel)	Item No.: 0150-1583
PR01-84x80-SSC-C/48x240F-C-300-L	(hollow Shaft Stainless Steel)	Item No.: 0150-2555

Variants model PR01-84 with planetary gear

PR01-84x80-C-G/48x240F-C-150-G05	gearbox 5:1	Item No.: 0150-2531
PR01-84x80-C-G/48x240F-C-150-G07	gearbox 7:1	Item No.: 0150-2532
PR01-84x80-C-G/48x240F-C-150-G10	gearbox 10:1	Item No.: 0150-2533
PR01-84x80-C-G/48x360F-C-150-G05	gearbox 5:1	Item No.: 0150-2535
PR01-84x80-C-G/48x360F-C-150-G07	gearbox 7:1	Item No.: 0150-2536
PR01-84x80-C-G/48x360F-C-150-G10	gearbox 10:1	Item No.: 0150-2537

Technical data model PR01-52

	Unit	PR01-52x40-R/ 37x120F-HP-C-80 (-L)	PR01-52x60-R/ 37x120F-HP-C-100 (-L)	PR01-52x60-R/ 37x120F-HP-C-150 (-L)			
Linear Motor*							
Max Stroke	mm	80	100	150			
Short stroke range	mm	70	90	145			
Peak Force ****	N	255 (-L 229)	255 (-L 229)	255 (-L 229)			
Cont. Force with Fan ****	N	92 (-L 82)	92 (-L 82)	92 (-L 82)			
Cont Force ****	N	51 (-L 45)	51 (-L 45)	51 (-L 45)			
Max Velocity	m/s	3.9	3.9	3.9			
Max Current	A	15	15	15			
Force Constant	N/A	17	17	17			
Repeatability	mm	+/- 0.05	+/- 0.05	+/- 0.05			
Phase Resistance (20°C)	Ohm	2.35	2.35	2.35			
Phase Induction	mH	1.6	1.6	1.6			
Linearity	%	+/- 0.1	+/- 0.1	+/- 0.1			
Rotary Motor*							
Peak Torque (stall) ($M_{0\ Max}$)	Nm	1.53	2.2	2.2			
Continuous Torque (stall)	Nm	0.32	0.47	0.47			
Continuous Torque (stall) with Fan	Nm	0.47	0.68	0.68			
Recommended max revolution (n_{Max})	rpm	1500	1500	1500			
Max Current**	A_{rms}	5.66	9.55	9.55			
Torque constant	Nm/A_{rms}	0.27	0.23	0.23			

	Unit	PR01-52x40-R/ 37x120F-HP-C-80 (-L)	PR01-52x60-R/ 37x120F-HP-C-100 (-L)	PR01-52x60-R/ 37x120F-HP-C-150 (-L)			
Concentricity (max stroke without payload)	mm	<+/-0.05	<+/-0.05	<+/-0.07			
Phase Resistance (20°C)	Ohm	7.1	3	3			
Induction	mH	4.8	2.8	2.8			
Repeatability	°	+/- 0.1 (+/-3')	+/- 0.1 (+/-3')	+/- 0.1 (+/-3')			
Mechanical Dimensions***							
Length	mm	503	565	704			
Diameter Linear Motor	mm	37	37	37			
Diameter Rotary Motor	mm	52	52	52			
Fitting Flange (front)	mm	30	30	30			
Mass Total	kg	2.68	3.12	3.7			
Moving mass (linear)	kg	0.79	0.86	0.95			
Moment of inertia (rotation)	kgcm2	0.22	0.26	0.31			
Diameter shaft	mm	12h9	12h9	12h9			
Option hollow Shaft		yes	yes	yes			
Diameter hole (-L version)		2.5 mm / max 6bar Connections: slider 1/8" rod 5 mm	2.5 mm / max 6bar Connections: slider 1/8" rod 5 mm	2.5 mm /max 6bar Connections: slider 1/8" rod 5 mm			
Protection Class		IP64	IP64	IP64			

Specification of products are subject to change without notification

* with Drive E1200-UC series

** Attention: LinMot Talk shows peak current -->($I_{rms} = I_{peak}/1.4$)

***details see drawings

**** hollow Shaft versions -L: 10% reduced force (data in bracket)

Technical data model PR0152 with planetary gear

	Unit	PR01-52x60-R/ 37x120F-HP- C-100-G05	PR01-52x60-R/ 37x120F-HP- C-100-G10				
Linear Motor*							
Max Stroke	mm	100	100				
Short stroke range	mm	90	90				
Peak Force ****	N	255	255				
Cont. Force with Fan ****	N	92	92				
Cont Force ****	N	51	51				
Max Velocity	m/s	3.9	3.9				
Max Current	A	15	15				
Force Constant	N/A	17	17				
Repeatability	mm	+/- 0.05	+/- 0.05				
Phase Resistance (20°C)	Ohm	2.35	2.35				
Phase Induction	mH	1.6	1.6				
Linearity	%	+/- 0.1	+/- 0.1				
Rotary Motor*							
Peak Torque (stall) (M _{0 Max})	Nm	2.2	2.2				
Continuous Torque (stall)	Nm	0.47	0.47				
Continuous Torque (stall) with Fan	Nm	0.68	0.68				
Recommended max revolution (n _{Max})	U/min	1500	1500				
Max Current**	A _{rms}	9.55	9.55				
Torque constant	Nm/A _{rms}	0.23	0.23				

	Einheit	PR01-52x60-R/ 37x120F-HP- C-100-G05	PR01-52x60-R/ 37x120F-HP- C-100-G10				
Gear ratio	i	5	10				
max revolution	U/min	300	150				
Peak Torque (gearbox output)	Nm	10 Nm	20 Nm				
Continuous Torque (gearbox output)	Nm	2 Nm	4 Nm				
Phase Resistance (20°C)	Ohm	3	3				
Induction	mH	2.8	2.8				
Repeatability	°	+/- 0.1 (*/-3')	+/- 0.1 (*/-3')				
Backlash of planetary gear	arcmin	<10	<10				
Mechanical Dimensions***							
Length	mm	620	620				
Diameter Linear Motor	mm	37	37				
Diameter Rotary Motor	mm	52	52				
Mass Total	kg	5.15	5.15				
Moving mass (linear)	kg	2.4	2.4				
Moment of inertia (rotation)	kgcm ²	2	2				
Option hollow Shaft		--	--				
Protection Class		IP64	IP64				

Technical data model PR01-84

	Unit	PR01-84x80- C/48x240F- C-100 (-L)	PR01-84x80- C/48x360F- C-100 (-L)	PR01-84x80- C/48x240F- C-150 (-L)	PR01-84x80- C/48x360F- C-150 (-L)	PR01-84x80- SSC-C/ 48x240F- C-150 (-L)	PR01-84x80- SSC-C/ 48x360F- C-150 (-L)	PR01-84x80- C/48x240F- C-300 (-L)	PR01-84x80- SSC-C/ 48x240F- C-300 (-L)
Linear Motor*									
Max Stroke	mm	130	130	150	150	150	150	300	300
Short stroke range	mm	100	100	100	100	100	100	200	200
Peak Force****	N	572 (-L 514)	1024 (-L 921)	572 (-L 514)	1024 (-L 921)	572 (-L 514)	1024 (-L 921)	572 (-L 514)	514
Cont. Force with Fan****	N	255 (-L 230)	354 (-L 319)	255 (-L 230)	354 (-L 319)	255 (-L 230)	354 (-L 319)	255	255
Cont Force****	N	145 (-L 130)	203 (-L 182)	145 (-L 130)	203 (-L 182)	145 (-L 130)	203 (-L 182)	145	145
Max Velocity	m/s	3	2.1	3	2.1	3	2.1	3	3
Max Current	A	26	32	26	32	26	32	26	26
Force Constant	N/A	22	32	22	32	22	32	22	22
Repeatability	mm	+/- 0.05	+/- 0.05	+/- 0.05	+/- 0.05	+/- 0.05	+/- 0.05	+/- 0.05	+/- 0.05
Phase Resistance (20°C)	Ohm	1.0	1.38	1.0	1.38	1.0	1.38	1.0	1.0
Phase Induction	mH	1.0	1.6	1.0	1.6	1.0	1.6	1.0	1.0
Linearity	%	+/- 0.15	+/- 0.15	+/- 0.15	+/- 0.15	+/- 0.15	+/- 0.15	+/- 0.15	+/- 0.15
Rotary Motor*									
Peak Torque (stall) (M _{0 Max})	Nm	8.9	8.9	8.9	8.9	8.9	8.9	8.9	8.9
Continuous Torque (stall)	Nm	1.9	1.9	1.9	1.9	1.9	1.9	1.9	1.9
Continuous Torque (stall) mit Fan	Nm	2.64	2.64	2.64	2.64	2.64	2.64	2.64	2.64
Recommended max revolution (n _{Max})	rpm	1000	1000	1000	1000	1000	1000	1000	1000
Max Current**	A _{rms}	17.68	17.68	17.68	17.68	17.68	17.68	17.68	17.68
Torque constant	Nm/A _{rms}	0.5035	0.5035	0.5035	0.5035	0.5035	0.5035	0.5035	0.5035

LinMot Linear Rotary Motors



	Unit	PR01-84x80-C/48x240F-C-100 (-L)	PR01-84x80-C/48x360F-C-100 (-L)	PR01-84x80-C/48x240F-C-150 (-L)	PR01-84x80-C/48x360F-C-150 (-L)	PR01-84x80-SSC-C/48x240F-C-150 (-L)	PR01-84x80-SSC-C/48x360F-C-150 (-L)	PR01-84x80-C/48x240F-C-300 (-L)	PR01-84x80-SSC-C/48x240F-C-300 (-L)
Concentricity (max stroke without payload)	mm	<+/-0.05	<+/-0.05	<+/-0.07	<+/-0.07	<+/-0.07	<+/-0.07	<+/-0.3	<+/-0.3
Phase Resistance (20°C)	Ohm	1.1	1.1	1.1	1.1	1.1	1.1	1.1	1.1
Induction	mH	4.3	4.3	4.3	4.3	4.3	4.3	4.3	4.3
Repeatability	°	+/- 0.1 (*/-3')	+/- 0.1 (*/-3')	+/- 0.1 (*/-3')	+/- 0.1 (*/-3')	+/- 0.1 (*/-3')	+/- 0.1 (*/-3')	+/- 0.1 (*/-3')	+/- 0.1 (*/-3')
Mechanical Dimensions***									
Length	mm	726	846	759	879	819	959	1222	1222
Diameter Linear Motor	mm	48	48	48	48	48	48	48	48
Diameter Rotary Motor	mm	84	84	84	84	84	84	84	84
Fitting Flange (front)	mm	35	35	48	48	48	48	48	48
Mass Total	kg	8.85	10.48	9.52	11.15	11	12.4	12.5	12.5
Moving mass (linear)	kg	2.5	2.9	2.6	3.2	3.2	3.2	3.6	3.6
Moment of inertia (rotation)	kgcm ²	2.0	2.0	2.3	2.3	2.3	2.3	2.4	2.4
Diameter shaft	mm	20h9	20h9	20h9	20h9	20h9	20h9	20h9	20h9
Option hollow Shaft in shaft		yes	yes	yes	yes	yes	yes	no	yes
Diameter hole (-L version)		4 mm / max 6 bar Connections: slider G1/4 rod G1/8	4 mm / max 6 bar Connections: slider G1/4 rod G1/8	4 mm / max 6 bar Connections: slider G1/4 rod G1/8	4 mm / max 6 bar Connections: slider G1/4 rod G1/8	4 mm / max 6 bar Connections: slider G1/4 rod G1/8	4 mm / max 6 bar Connections: slider G1/4 rod G1/8	4 mm / max 6 bar Connections: slider G1/4 rod G1/8	4 mm / max 6 bar Connections: slider G1/4 rod G1/8
Protection Class		IP64	IP64	IP64	IP64	IP64 / IP67	IP64 / IP67	IP64	IP64 / IP67

Specification of products are subject to change without notification * with Drive E1200-UC series

** Attention: LinMot Talk shows peak current -->(I_{rms}:= I_{peak}/1.4)
 *** details see drawings
 **** hollow Shaft versions -L: 10% reduced force (data in bracket)

Technical data model PR01-84 with planetary gear

	Unit	PR01-84x80-C/ 48x240F- C-150-G05	PR01-84x80-C/ 48x240F- C-150-G07	PR01-84x80-C/ 48x240F- C-150-G10	PR01-84x80-C/ 48x360F- C-150-G05	PR01-84x80-C/ 48x360F- C-150-G07	PR01-84x80-C/ 48x360F- C-150-G10
Linear Motor*							
Max Stroke	mm	150	150	150	150	150	150
Short stroke range	mm	100	100	100	100	100	100
Peak Force****	N	572	572	572	1024	1024	1024
Cont. Force with Fan****	N	255	255	255	354	354	354
Cont Force****	N	145	145	145	203	203	203
Max Velocity	m/s	3	3	3	2.1	2.1	2.1
Max Current	A	26	26	26	32	32	32
Force Constant	N/A	22	22	22	32	32	32
Repeatability	mm	+/- 0.05	+/- 0.05	+/- 0.05	+/- 0.05	+/- 0.05	+/- 0.05
Phase Resistance (20°C)	Ohm	1.0	1.0	1.0	1.38	1.38	1.38
Phase Induction	mH	1.0	1.0	1.0	1.6	1.6	1.6
Linearity	%	+/- 0.15	+/- 0.15	+/- 0.15	+/- 0.15	+/- 0.15	+/- 0.15
Rotary Motor*							
Peak Torque (stall) ($M_{0\ Max}$)	Nm	8.9	8.9	8.9	8.9	8.9	8.9
Continuous Torque (stall)	Nm	1.9	1.9	1.9	1.9	1.9	1.9
Continuous Torque (stall) with Fan	Nm	2.64	2.64	2.64	2.64	2.64	2.64
Recommended max revolution (n_{Max})	U/min	1000	1000	1000	1000	1000	1000
Max Current**	A_{rms}	17.68	17.68	17.68	17.68	17.68	17.68
Torque constant	Nm/A_{rms}	0.5035	0.5035	0.5035	0.5035	0.5035	0.5035

LinMot Linear Rotary Motors



	Unit	PR01-84x80-C/ 48x240F-C-150- G05	PR01-84x80-C/ 48x240F-C-150- G07	PR01-84x80-C/ 48x240F-C-150- G10	PR01-84x80-C/ 48x360F-C-150- G05	PR01-84x80-C/ 48x360F-C-150- G07	PR01-84x80-C/ 48x360F-C-150- G10
Gear ratio	i	5	7	10	5	7	10
max revolution	U/min	200	142	100	200	142	100
Peak Torque (gearbox output)	Nm	40	56	75	40	56	75
Continuous Torque (gearbox output)	Nm	8.5	12	17	8.5	12	17
Phase Resistance (20°C)	Ohm	1.1	1.1	1.1	1.1	1.1	1.1
Induction	mH	4.3	4.3	4.3	4.3	4.3	4.3
Repeatability	°	+/- 0.1 (*/-3')	+/- 0.1 (*/-3')	+/- 0.1 (*/-3')	+/- 0.1 (*/-3')	+/- 0.1 (*/-3')	+/- 0.1 (*/-3')
Backlash of planetary gear	arcmin	<10	<10	<10	<10	<10	<10
Mechanical Dimensions***							
Length	mm	862	862	862	982	982	982
Diameter Linear Motor	mm	48	48	48	48	48	48
Diameter Rotary Motor	mm	84	84	84	84	84	84
Mass Total	kg	13.0	13.0	13.0	14.6	14.6	14.6
Moving mass (linear)	kg	6.73	6.73	6.73	7.33	7.33	7.33
Moment of inertia (rotation)	kgcm2	2.3	2.3	2.3	2.3	2.3	2.3
Option hollow Shaft in shaft		--	--	--	--	--	--
Protection Class		IP64	IP64	IP64	IP64	IP64	IP64

Specification of products are subject to change without notification

* with Drive E1200-UC series

** Attention: LinMot Talk shows peak current --> ($I_{rms} = I_{peak}/1.4$)

*** details see drawings

**** hollow Shaft versions -L: 10% reduced force (data in bracket)

NOTE: Gearbox motors may regenerate a lot of energy into the DC-Link → use drives with brake resistor or use additional DC-Link capacitor (10'000 uF)

Torque-Speed Curve Rotary Motors

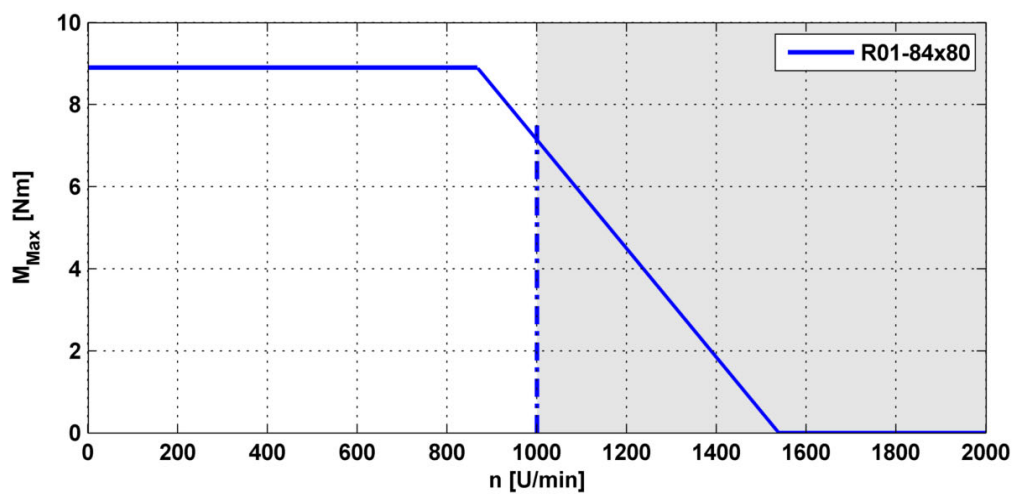
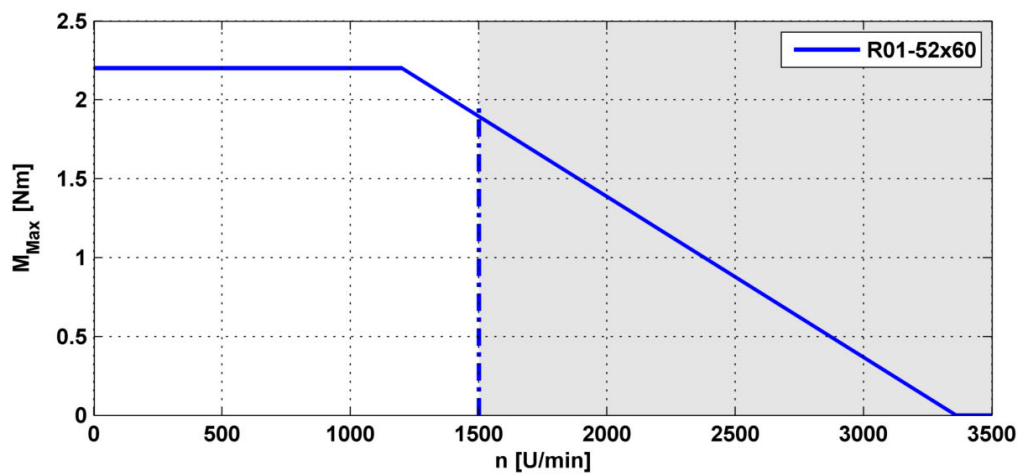
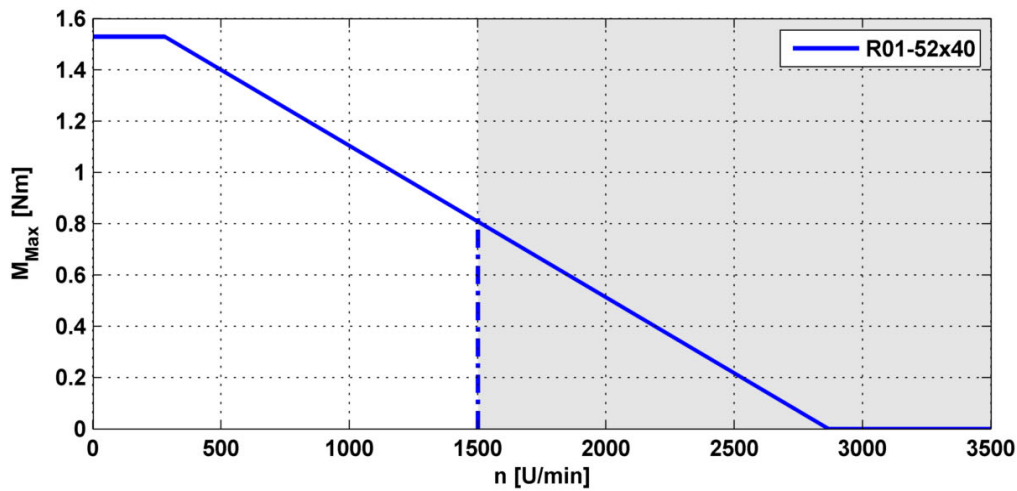

Startup

The linear motor and rotary motor are electrically independent units. This means that the Linear Rotary Motor can be started up sequentially. It makes no difference which motor (linear or rotary) is started up first.

Drive settings

The various parameters for the linear motor and the rotary motor are set using the corresponding wizard in the LinMot Talk configuration program. (Contact LinMot Support if you do not see the folder "Motors\LinMot Linear Rotary Motor".)

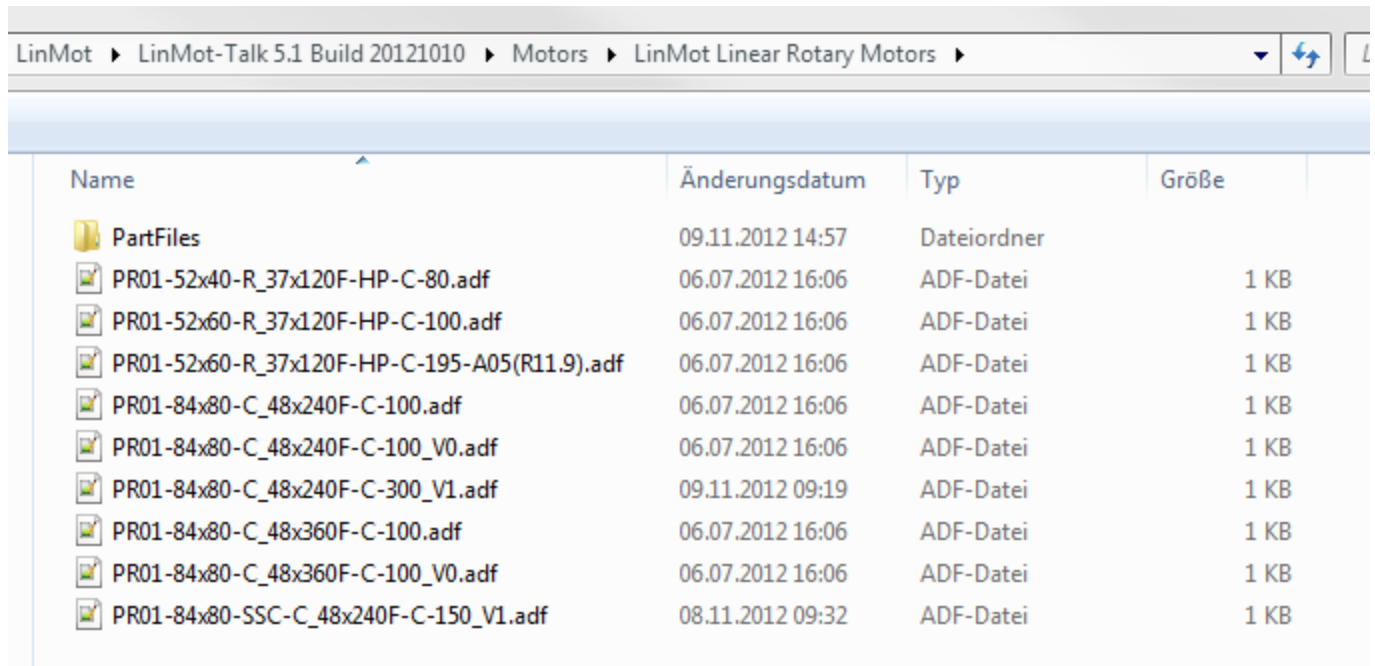

Name	Änderungsdatum	Typ	Größe
PartFiles	09.11.2012 14:57	Dateiordner	
PR01-52x40-R_37x120F-HP-C-80.adf	06.07.2012 16:06	ADF-Datei	1 KB
PR01-52x60-R_37x120F-HP-C-100.adf	06.07.2012 16:06	ADF-Datei	1 KB
PR01-52x60-R_37x120F-HP-C-195-A05(R11.9).adf	06.07.2012 16:06	ADF-Datei	1 KB
PR01-84x80-C_48x240F-C-100.adf	06.07.2012 16:06	ADF-Datei	1 KB
PR01-84x80-C_48x240F-C-100_V0.adf	06.07.2012 16:06	ADF-Datei	1 KB
PR01-84x80-C_48x240F-C-300_V1.adf	09.11.2012 09:19	ADF-Datei	1 KB
PR01-84x80-C_48x360F-C-100.adf	06.07.2012 16:06	ADF-Datei	1 KB
PR01-84x80-C_48x360F-C-100_V0.adf	06.07.2012 16:06	ADF-Datei	1 KB
PR01-84x80-SSC-C_48x240F-C-150_V1.adf	08.11.2012 09:32	ADF-Datei	1 KB

The Linear Rotary Motors are located in the folder "Motors\LinMot Linear Rotary Motors". It makes no difference whether the linear or rotary motor is configured first.

Configuration Linear Motor

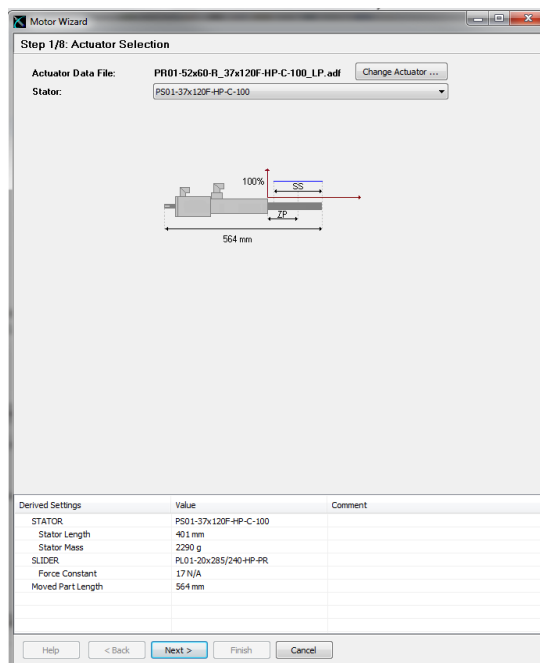
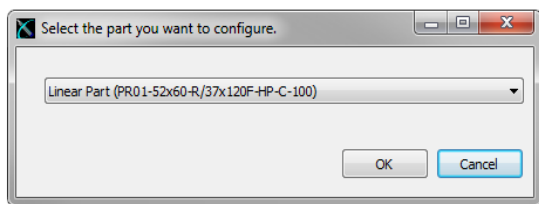

Figures: LinMot-Talk Motor Wizard: Linear part Actuator Selection

Configuration Rotary Motor

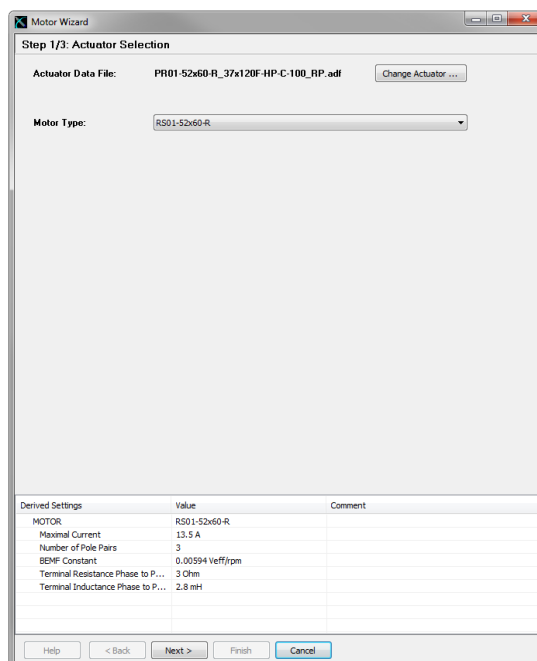
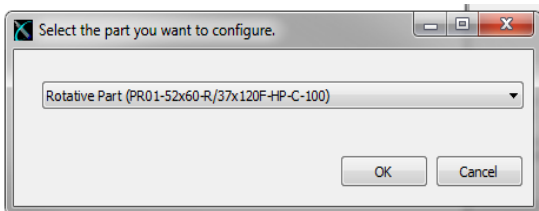

Figures: LinMot-Talk Motor Wizard: Rotative Part Actuator Selection

Homing the Rotary Motor

No homing is necessary, because the rotary motor uses an absolute measurement system (single turn).

Homing the Linear Motor

If the linear motor is homed to the internal stop of the Linear Rotary Motor, then the maximum homing velocity must be no greater than 0.01 m/s.

Example of VAI motion with Rotary Motor

The LinMot Talk program uses units on the parameter page the same way they are used to actuate linear motors. In order to control a rotary motor, therefore, a ratio between one motor revolution (360°) and the linear travel distance must be defined (**by default, 1 revolution through 360° corresponds to a linear travel distance of 36 mm**).

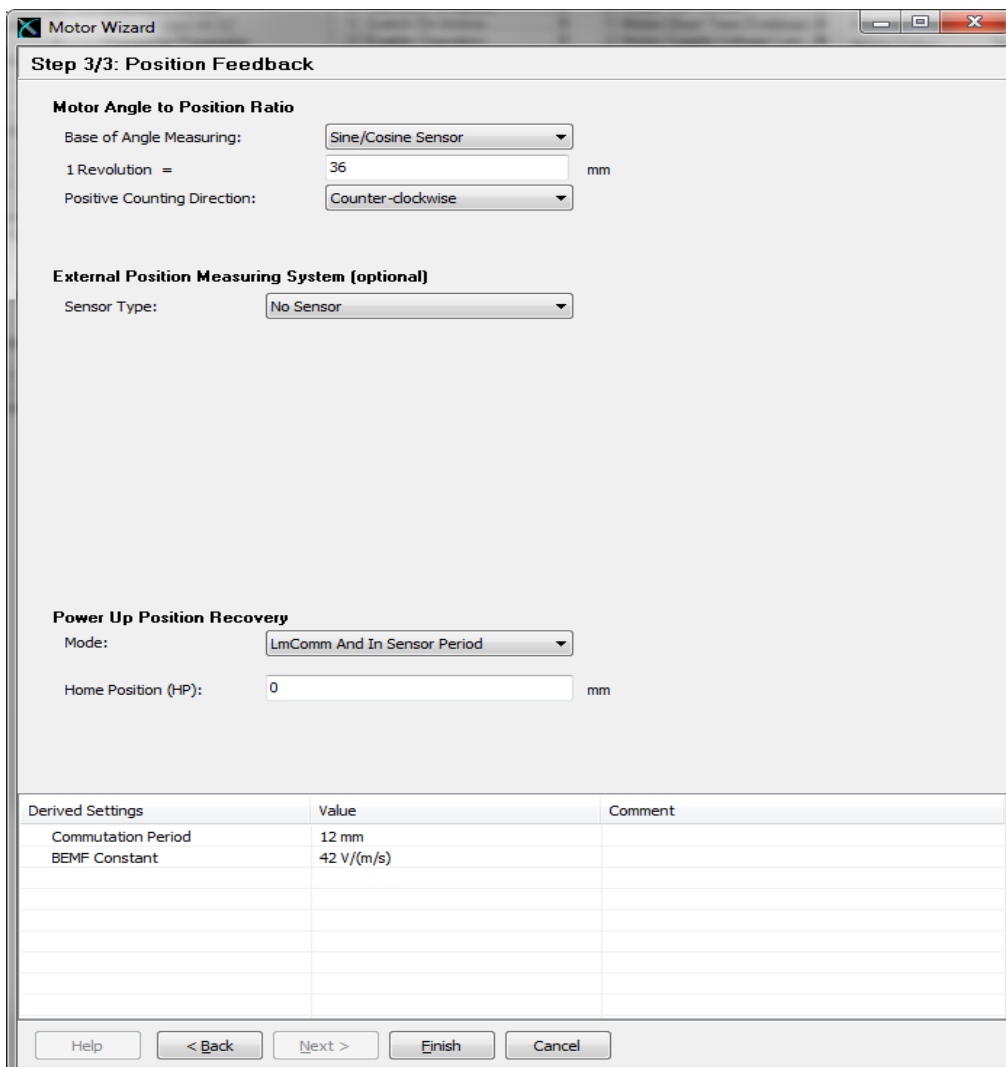

Figure: Motor Wizard: Motor Angle to Position Ratio

The ratio can be freely defined. Keep in mind that the "position" parameter type is defined as a 32-bit value and the maximum position resolution is 0.1 µm. This means that the maximum stroke is limited to between -214748 mm and 214748 mm.

Position [mm]	-214748 to 214748
1 revolution = 36 mm (1° == 0.1 mm)	Maximum number of revolutions = 11930 (recommended)
1 revolution = 360 mm (1° == 1 mm)	Maximum number of revolutions = 1193

The ratio, however, affects not only the positions but also the PID controller. The table below shows an example of this:

P [A/ mm]	5
1 revolution = 36 mm (1° == 0.1 mm)	For a deviation of 1°, the drive reacts with 0.5 A
1 revolution = 360 mm (1° == 1 mm)	For a deviation of 1°, the drive reacts with 5 A

This means that if the "Motor Angle to Position Ratio" is changed, the controller parameters must be (manually) adjusted as well.

Example of motion using a VAI motion command

A VAI Motion Command (motion using the Velocity Acceleration Interpolator) can be started directly via the LinMot Talk program.

1) Definition of the movement:

Number of revolutions	25
Acceleration phase	100 [ms]
Maximal velocity	1500 [rpm]
Delay	50 [ms]
1 Revolution	36 [mm]

2) Converting the rotary parameters into the linear system:

$$\text{Target Position [mm]} = \text{Number of revolutions} * 36 [\text{mm}] = 900 [\text{mm}]$$

$$\text{Maximal Velocity [m/s]} = (1500 [1/\text{min}] * 0.036 [m]) / 60 = 0.9 [m/s]$$

$$\text{Acceleration [m/s}^2\text{]} = \text{Maximal Velocity [m/s]} / 0.1 [s] = 9 [m/s^2]$$

$$\text{Deceleration [m/s}^2\text{]} = \text{Maximal Velocity [m/s]} / 0.05 [s] = 18 [m/s^2]$$

3) Entering the parameters in LinMot-Talk → Control Panel → Motion Cmd Interface

Enable Manual Override: -10 mm -1 mm +1 mm +10 mm

Command Category: Most Commonly Used

Command Type: VAI Go To Pos (010xh) ?

Count Nibble (Toggle Bits): 1h Auto Increment Count Nibble

Name	Offs.	Description	Scaled Value	Int. Value (Dec)	Int. Value (Hex)
Header	0	010xh: VAI Go To Pos	257	257	0101h
1. Par	2	Target Position	900 mm	9000000	00895440h
2. Par	6	Maximal Velocity	0.9 m/s	900000	000DBBA0h
3. Par	10	Acceleration	9 m/s ²	900000	000DBBA0h
4. Par	14	Deceleration	18 m/s ²	1800000	001B7740h

Read Command
Send Command

Using the oscilloscope (integrated in LinMot-Talk Software), the motion can be recorded and the PID control parameters can be adjusted as needed.

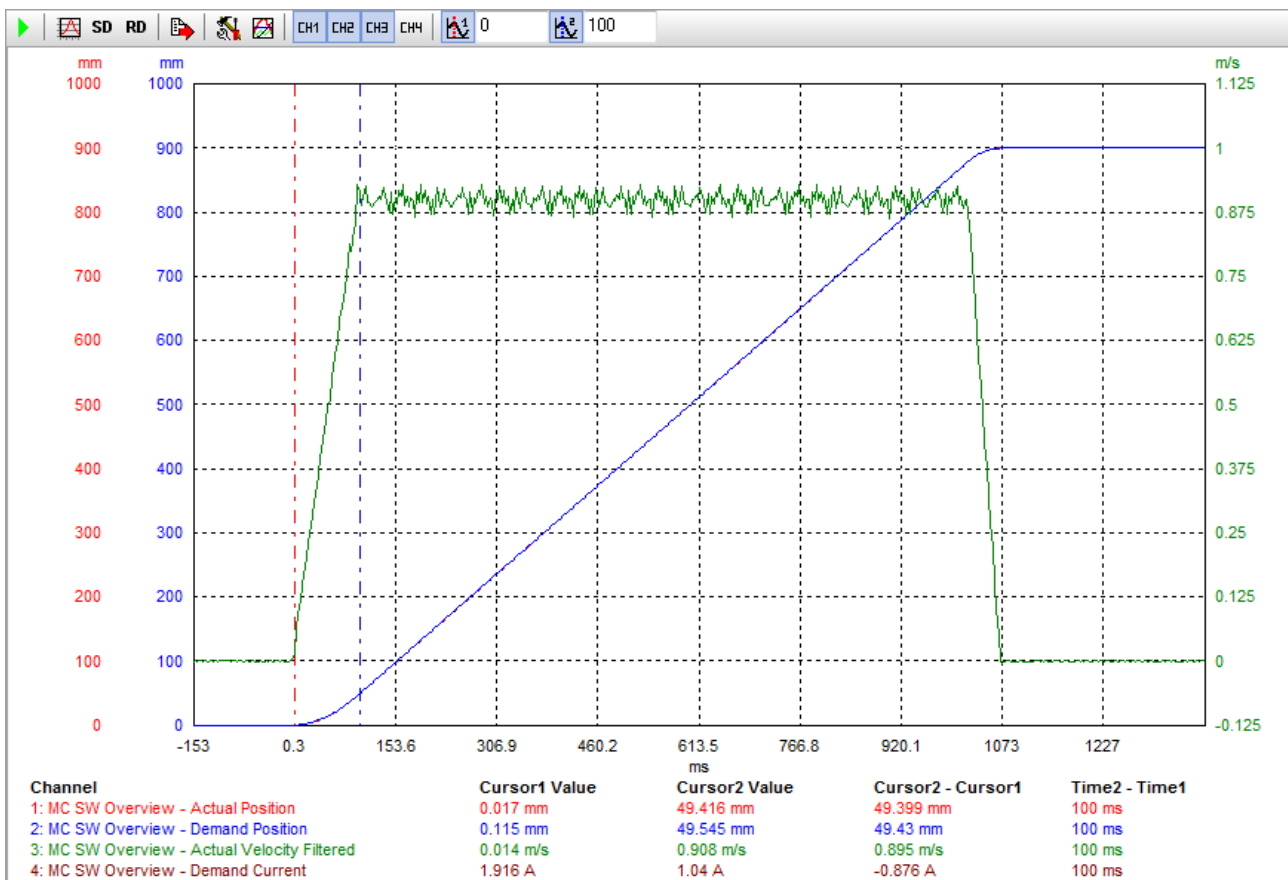

Picture: LinMot-Talk - Oscilloscope

Notes on operating the Linear Rotary Motor

Running in the mechanical end stop may damage the motor

During operation the linear motor must not be allowed to strike the upper or lower internal stops, as this can cause damage to the Linear Rotary Motor. The internal stops can be used for homing purposes, but the homing speed must not exceed the value of 0.01 m/s. Specially by using a MagSpring for the weight balancing and no payload is attached, the MagSpring may shoot the unit into the internal stop and damage the unit! Use an external stop ring attached to the rod or cable tie holding an adapter to prevent this situation. -->Do not remove the stop ring/cable tie as long as no payload is mounted!

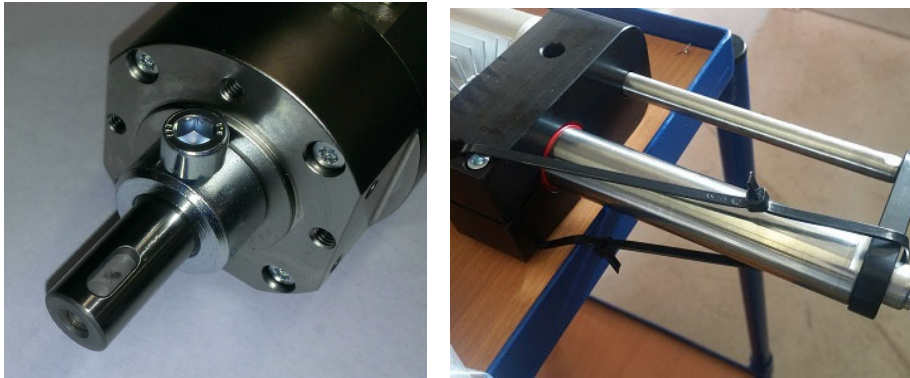

Figures: External stop ring attached to the rod / cable tie holding an adapter

Strategy for the linear and rotating movement

The Linear Rotary Motor is designed to execute linear and rotary motions simultaneously. This means that the rotary and linear motions can be executed simultaneously and completely independent of one another. If the application permits, however, the following guidelines should be followed for physical technical reasons:

Rotary motions should be performed with the linear axis retracted if possible, as this can reduce vibrations and mechanical loads due to asymmetrical load mass. Execute rotary and linear motions sequentially, which makes the load on the electrical power source more uniform and thus leads to greater energy efficiency.

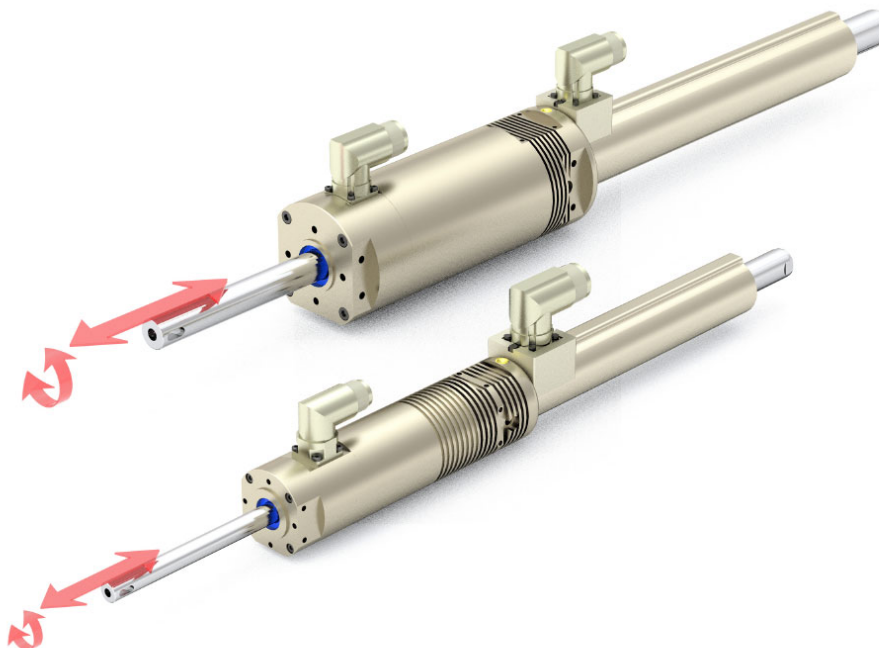

Figure: linear and rotative motion

Linear Rotary Motors with planetary gear

Linear Rotary Motors with planetary gear will be used in all applications with high moment of inertia or high torque requirement.

Model PR01-52 with planetary gear

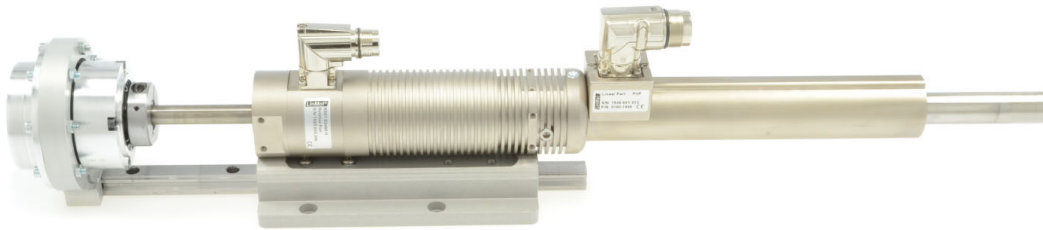

Figure: PR01-52x60-R-G/37x120F-HP-C-100-G05

Model PR01-84 with planetary gear



Figure: PR01-84x80-C-G/48x240F-C-150-G10

Stainless Steel variant of the PR01-84x80-SSC series

In addition to standard Linear Rotary Motors, variants made of chromium steel are available in the PR01-84 series. Both the front flange and the rotary axis are made of chromium steel 1.4404 (V4A). The rotary axis is sealed against the stator.

For maintenance purposes, the front Item of the flange, where the seals and guides are located, can be removed. The Linear Rotary Motor does not need to be removed from the system in order to remove the flange.



Figure: PR01-84x80-SSC-C/48x240F-C-150



Figure: PR01-84x with screwed-off front part of the flange

Front Item of the flange, includes sealing and bearings, can be replaced easily. Normally the complete front Item with all seals and bearings will be replaced. In case that the seals and bearings are only cleaned the following lubricant has to be used: "fin food Grease 2" from INTERFLON

Notes on application of the PR01-84x80-SSC series

The design of the machine should consist of a 'normal' and a 'Stainless Steel' zone. The 'Stainless Steel zone' can be cleaned accordingly during operation. The two zones are separated by a Stainless Steel plate. The flange of the Linear Rotary Motor, also made of Stainless Steel, is inserted through this steel plate. The cylindrical front end of the flange has a groove with an O-ring that acts as a seal between the 'normal' and the Stainless Steel zones.



Figure: O-ring for sealing between 'normal' and 'Stainless Steel' zone.

Notes on cleaning the SSC variants

Both the linear and rotary axis should not be set in motion while the line is being cleaned. It should be either fully extended or fully retracted. The chromium steel zone has IP67 class protection. The seals are made from FKM fluoroelastomer and 85 AU 20991 polyester-urethane rubber.

Note

Linear Rotary Motor units with new or replaced seals will show an increased friction on both movements (linear and rotation) during the first hours of operation.

Special Application

Example: Linear Rotary Motors on a turntable



Figure: Linear Rotary Motors PR01-84 on turntable

Typical arrangement of a system with Linear Rotary Motors and drives on a turntable. The lowest turntable is the divider between the 'Stainless Steel' and 'normal' zones. The drives for actuating the motors are located above the Linear Rotary Motors.

Cam profile for E-stop in applications with rotary disk

A fast turning rotary disk can not be stopped quickly during a loss of power emergency. This means the Linear Rotary Motor could be damaged if the rod is unpowered in the extended position and collides with other fixtures or tooling. An emergency guide profile at the point of possible collision helps to solve this situation by lifting the slider motor into the up position to prevent damage to other machinery.

The following picture shows a possible application of a Cam Kit MF01-PK84 (Item No. 0250-2324). Cam Kit forces the Linear Rotary Motor trough the pulley upwards.

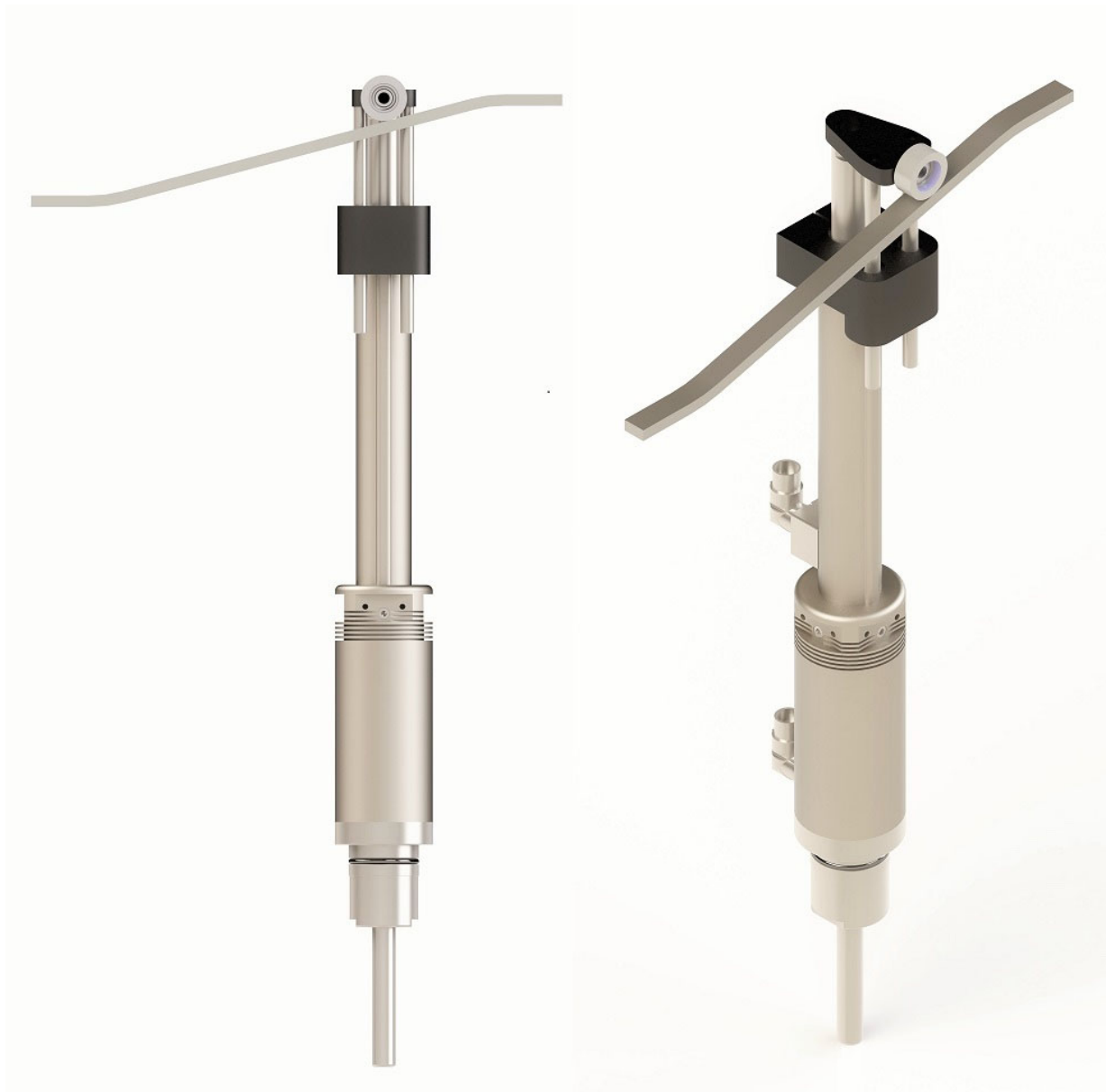
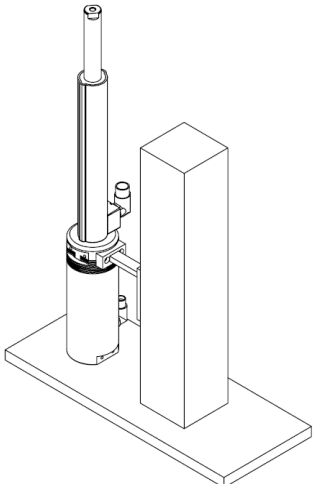
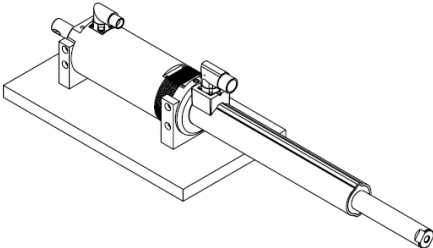
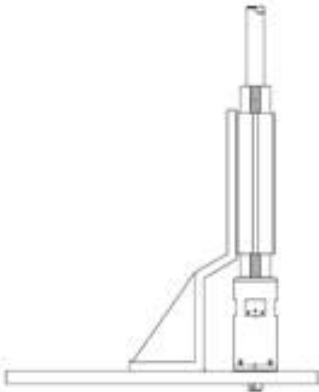

Figure: At the critical position the crank forces the moving Item of the Linear Rotary Motor up in case of a power breakdown. (Caution: Mechanical end stop is not shown!)

Caution: Make sure that the Cam Kit or any other auxiliary equipment that pulls or pushes the Linear Rotary Motor upwards has its own mechanical stop. Linear Rotary Motor internal collisions may not be used as an end stop in any case. Using Linear Rotary Motor internal collisions may damage the unit. In addition, the motor must be supported (see chapter Installing Linear Rotary Motors) to absorb any side load of the crank.

Installing Linear Rotary Motors

The PR01 Linear Rotary Motors have a center fit on the front side so that the rotary axis can be precisely aligned. Due to the narrow construction of the Linear Rotary Motors, it is most often not sufficient to mount them by the front bolts alone (due to vibration or lateral loads). An additional support is then necessary. From a technical point of view the support should be done at the end of the motor to reduce any oscillations. Note that tolerances must be compensated (e.g. through long holes) to eliminate any tension to the motor between the two mounting points. The following sketches show examples of the various possibilities. The chapter on installation drawings contains detailed dimensions.

	<p>Front mounting with side support</p>
	<p>Bottom mounting, mounted through Linear Rotary Motor side mounting holes</p> <p>Compensate tolerance using a washers (if necessary), when the Linear Rotary Motor is fixed through bottom mounting holes</p>
	<p>Angle and heat sinks support</p>

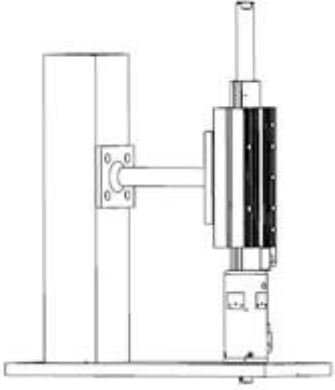
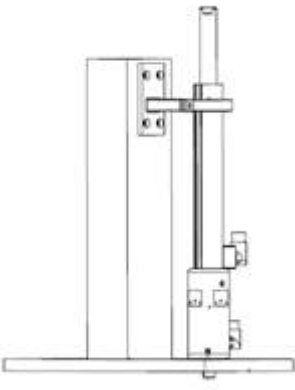
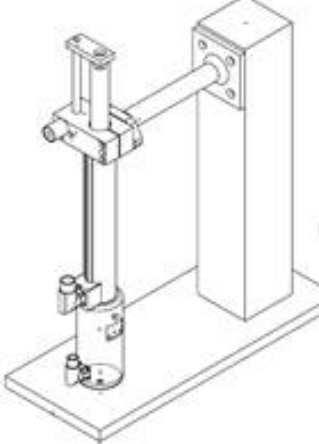
	<p>Support through cooling flange side section</p>
	<p>Support through the side section at the end of Linear motor</p>
	<p>Support through the Multifunction-Flange side section</p>

Drawings of Linear Rotary Motors with accessories

	<p>Linear Rotary Motor without accessories</p>
	<p>Linear Rotary Motor Motor with backside whipper</p>
	<p>Linear Rotary Motor with fan Kit for cooling of the Rotary Motor</p>

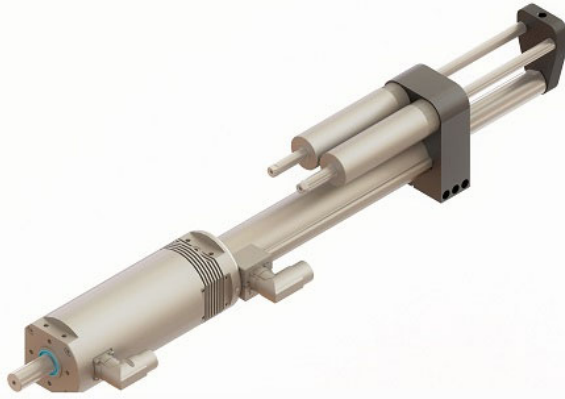

Linear Rotary Motor with two MagSprings, assembled on the left side.



Linear Rotary Motor with Cam Kit, assembled on the left side.



Linear Rotary Motor with MagSpring Kit UNO, mounting and heat sinks, assembled on the left side.

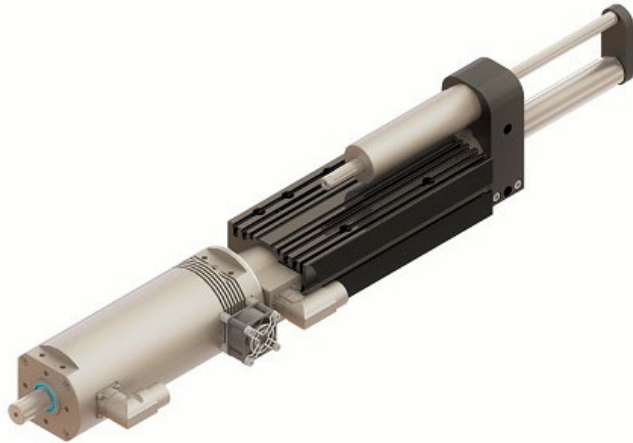

Linear Rotary Motor with MagSpring Kit UNO and flange, assembled on the left side.

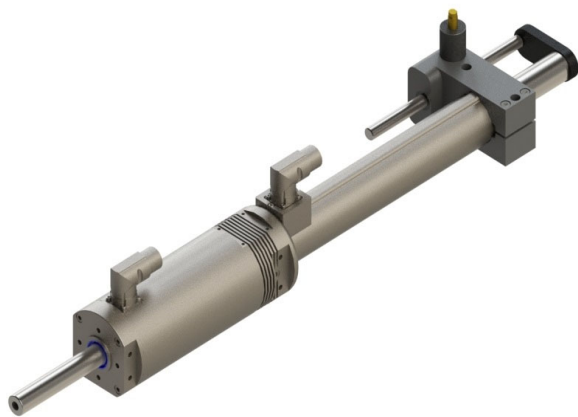

Linear Rotary Motor with Brake-Kit and Adapter, assembled on the left side.



Linear Rotary Motor with symmetric MagSpring Flange and Adapter

CAD-Files

CAD files and STEP files can be downloaded from the CAD download area on the webpage at www.LinMot.com

Accessories

Heat sinks for linear motors

The following heat sinks, in various lengths, help to cool the linear motor. If possible, the combined length of the heat sinks should cover the whole linear motor length.

Option heat sink for linear motor PS01-37x120F-HP-C-...

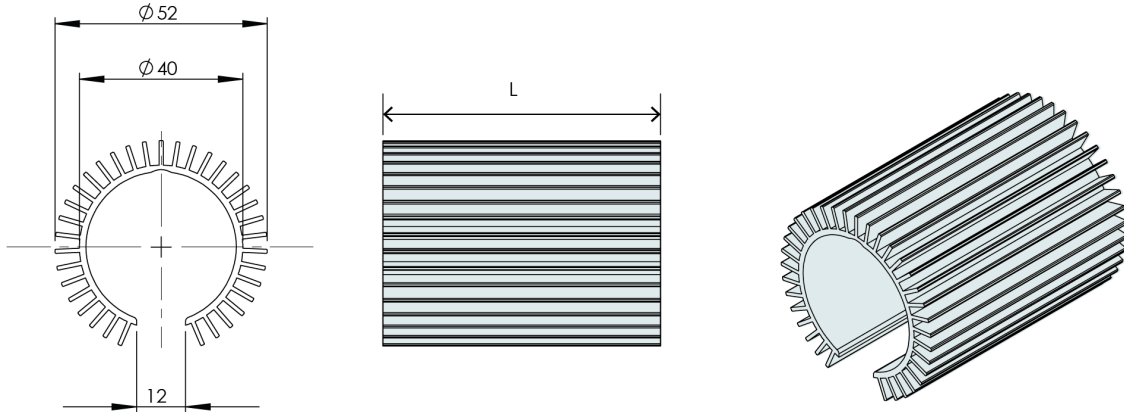

Article	Article	L [mm]	Mass [kg]	Item No.
PC01-37x68	heat sink	68	0.07	0160-2131
PC01-37x132	heat sink	132	0.14	0160-2156

Option heat sink for linear motor PS01-48x240F-C-... and PS01-48x360F-C-...

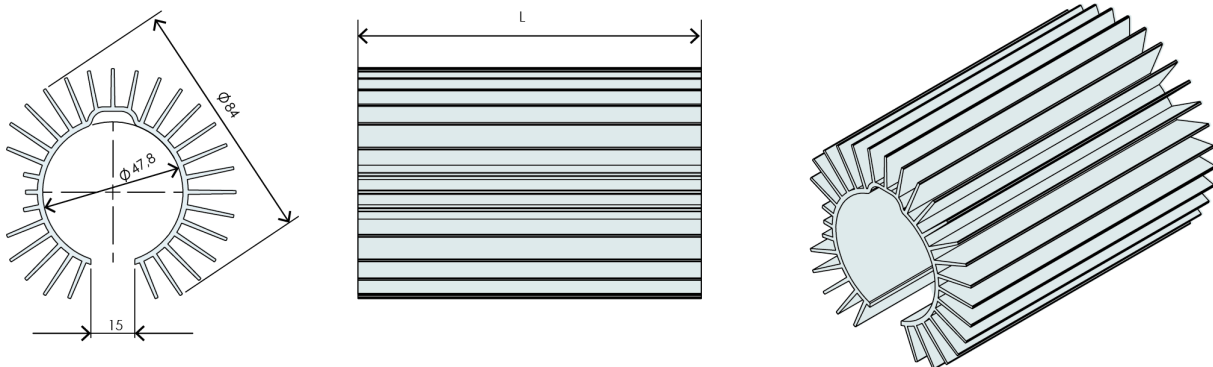

Article	Article	L [mm]	Mass [kg]	Item No.
PC01-48x100	heat sink	99	0.21	0160-2145
PC01-48x117	heat sink	117	0.25	0160-2138

Heat sinks combinations for linear motors

Linear motor	With MagSpring or Brake-Kit		Without Accessories	
	Item No.	Description	Item No.	Description
PS01-37x120F-HP-C-..	1x 0160-2131	PC01-37x68	2x 0160-2131	PC01-37x68
PS01-37x120F-HP-C-..	1x 0160-2156	PC01-37x132	1x 0160-2156	PC01-37x132

Linear motor	With MagSpring		With Cam-Kit		Without accessories	
	Item No.	Description	Item No.	Description	Item No.	Description
PS01-48x240F-C-..	2x 0160-2138	PC01-48x117	2x 0160-2145	PC01-48x100	2x 0160-2138	PC01-48x117
PS01-48x360F-C-..	3x 0160-2138	PC01-48x117	3x 0160-2145	PC01-48x100	3x 0160-2138	PC01-48x117

Mounting and cooling flange for linear motors

The following flanges, in various lengths, are used to mount the Linear Rotary Motor as well as cool the linear motor.

Option mounting and cooling flange for Linear Motor PS01-37x120F-HP-C-..

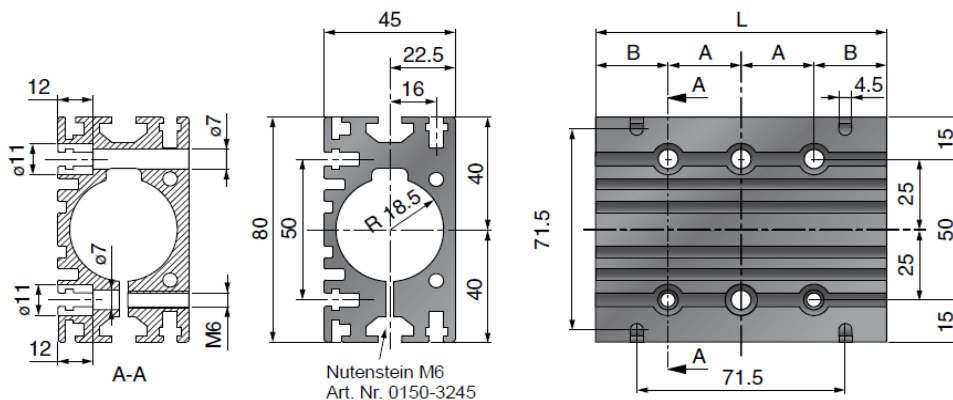

Nutenstein M6
Art. Nr. 0150-3245

Article	Article	L [mm]	A [mm]	B [mm]	Mass [kg]	Item No.
PF02-37x100	Flange 37x100 mm	100	25	25	0.45	0150-1998
PF02-37x140	Flange 37x140 mm	140	50	20	0.63	0150-2105

Option mounting and cooling flange for Linear Motors PS01-48x240F-C-... PS01-48x360F-C-...

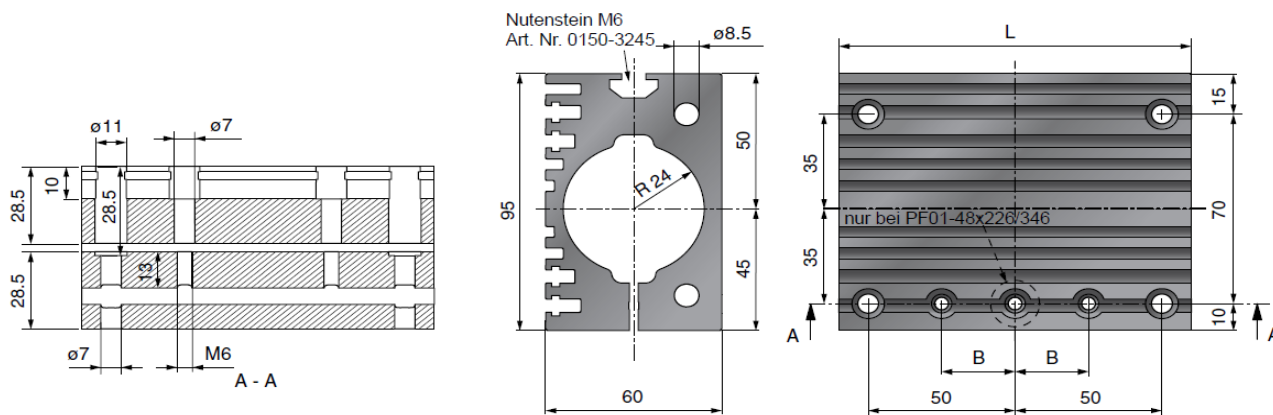

Nutenstein M6
Art. Nr. 0150-3245

nur bei PF01-48x226/346

Article	Article	L [mm]	B [mm]	Mass [kg]	Item No.
PF01-48x120	Flange 48x120 mm	120	25	0.97	0150-1976
PF01-48x226	Flange 48x226 mm	226	85	1.855	0150-2108

Fan Kits

Fan Kits are available for both the rotary motor and the linear motor. In general, forced ventilation allows the continuous torque or force to be increased (see design program).

Fan Kits for Linear Motor

Option: Fan for Linear Motor PS01-37x120F-HP-C-..

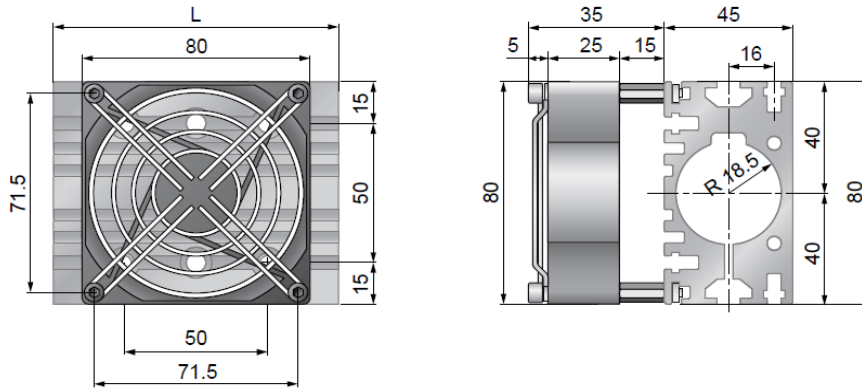

Connection: 24VDC / 120mA

Article	fan for	Item No.
HV01-37/48*	Fan Kit for H01-37, B01-37 and PF02-37	0150-5051

* order separate mounting and cooling Flange PF02-37x100 or PF02-37x140

Option: Fan for Linear Motor PS01-48x240F-C-.. / PS01-48x360F-C-...

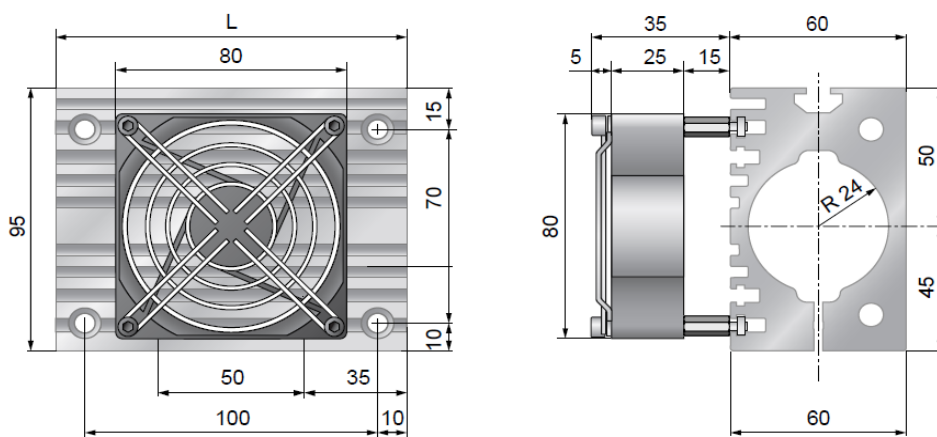

Connection: 24VDC / 120 mA

Article	fan for	Item No.
HV01-37/48*	Fan Kit for H01-48, B01-48 and PF01-48	0150-5051

* order separate mounting and cooling Flange PF01-48x120 or PF01-48x226

Fan Kit for Rotary Motors

Option: fan for Rotary Motor model PR01-52

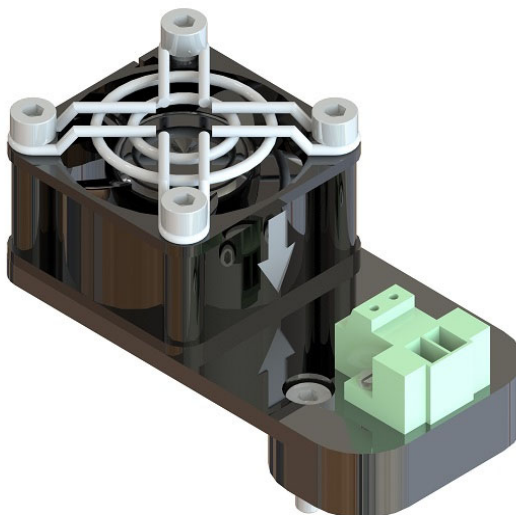

Figure: RS01-VA52

Connection: red = 24Vdc blue or black = GND

Article	fan for	Mass	Item No.
RS01-VA52-Kit	Rotary Motor RS01-52	0.075 kg	0150-1599

Option: fan for Rotary Motor model PR01-84



Figure: RS01-VA84

Connection: red = 24Vdc blue or black = GND

Article	fan for	Mass	Item No.
RS01-VA84-Kit	Rotary Motor RS01-84	0.03 kg	0150-1600

Wipers

The rotary axis is protected against dirt and loss of grease by a wiper on the front side. The back side of the linear motor slider should also be protected by means of a wiper. The options 'wiper' and 'multifunctional flange' are available for this.

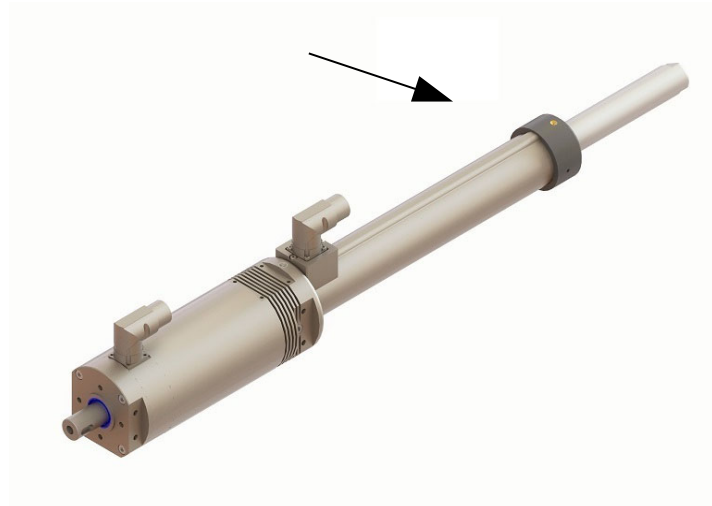
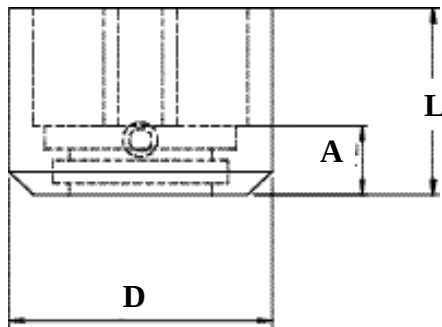

Figure: Dimensions and PR01-84x with PA01-48/28-F

	Description	Item No.	D	L	A	Mass
Wipers for model PR01-52 PS01-37x120F-HP-C-..	PA01-37/20-F	0150-3126	45 mm (1.77in)	32 mm (1.26in)	12 mm (0.47in)	0.028kg
Wipers for model PR01-84 PS01-48x240F-C-... PS01-48x360F-C-...	PA01-48/28-F	0150-3127	58 mm (2.28in)	32 mm (1.26in)	14 mm (0.55in)	0.056kg

Multifunction flange and MagSpring

The multifunctional flange can perform one or more of the following functions:

- Wiper for the linear motor slider
- Mounting a MagSpring spring for load compensation
- Mounting a pneumatic brake
- Mounting element for the Linear Rotary Motor

Mounting/Orientation of the accessories

MagSpring, Cam Kit and Brake-Kit can be assembled on both sides or back of the Linear Rotary Motor.



Figure: (left to right) “assembled on right side (Assembling Item No. 0140-0002)”, “on back side (Item No. 0140-0003)” and “on left side (**Default**, Item No. 0140-0004)”

NOTE: If there is no assembling Item No. or any information placed in order regarding assembling, ordered accessories will be shipped separately.

Direction force of the MagSpring

Depending on the orientation of the MagSpring slider, the direction of the force can be defined. This means that the MagSpring pulls the rotary axis of the Linear Rotary Motor inward, or pushes it outward.



Left: 'Pushing' MagSpring (Assembling Item No.: 0140-0005)
Right: 'Pulling' MagSpring (Assembling Item No.: 0140-0006) **(Default)**

Specially by using a MagSpring for the weight balancing and no payload is attached, the MagSpring may shoot the rod into the internal stop and damage the unit! Use an external stop ring attached to the rod to prevent this situation

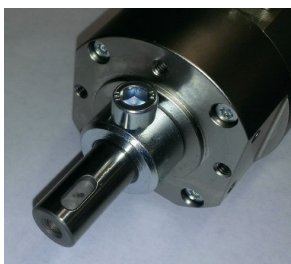
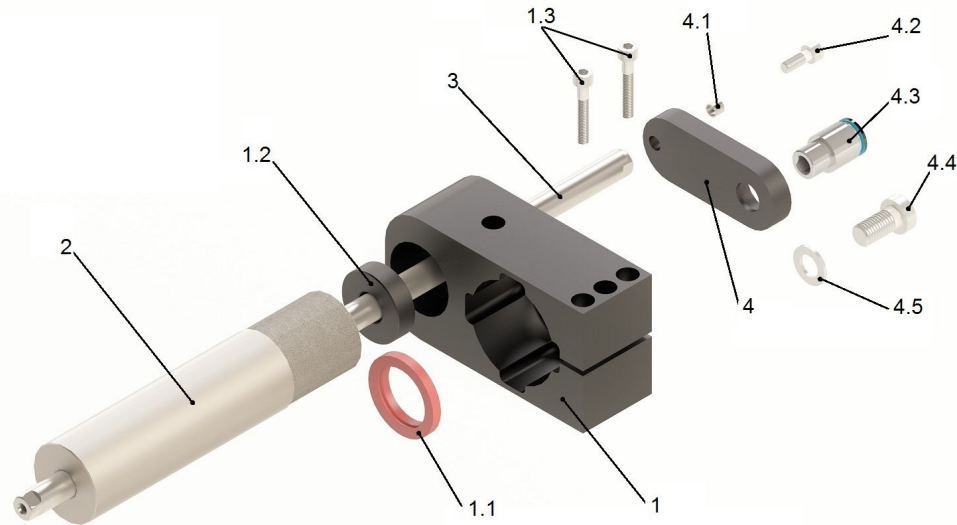

Figure: External stop ring attached to the rod

Overview MagSpring UNO



		Item / Item-No. for Type PR01-52 / PR01-52 -L			Item / Item-No. for Type PR01-84 / PR01-84 -L
MagSpring Force		22 N	40 N	60 N	60 N
1	Multifunction flange	MF01-PR01-52x40-20 Item-No. 0250-2322	MF01-PR01-52x40-37 Item-No. 0250-2319		MF01-PR01-84x37-1 Item-No. 0250-2337
1.1	Wipre	PAW01-20 / Item-No. 0150-3112			PAW01-28 Item-No. 0150-3133
1.2	Spacer washer	-			Spacer washer
1.3	Socket screws	2x M5x30 / ISO 4762			2x M5x35 / ISO 4762
2	MagSpring Stator	80 mm Stroke	MS01-20x140 Item-No. 0250-2201	MS01-37x155 Item-No. 0250-2204	-
		100 mm Stroke		MS01-37x170 Item-No. 0250-1017	MS01-37x155; Item-No. 0250-2204
		150 mm Stroke			MS01-37x170; Item-No. 0250-1017
		300 mm Stroke	-	-	MS01-37x305; Item-No. 0250-2206
3	MagSpring Slider	80 mm Stroke	ML01-12x350/160-20 Item-No. 0250-2321	ML01-12x350/160-10 Item-No. 0250-2333	ML01-12x350/160-20 Item-No. 0250-2321
		100 mm Stroke		ML01-12x375/160-10 Item.-No. 0250-1023	ML01-12x375/160-20 Art.-No. 0250-2326
		150 mm Stroke	ML01-12x375/180-20 Art.-No. 0250-1070		
		300 mm Stroke	-	-	ML01-12x650/320-20; Item-No. 0250-2343
4	Adapter	MA01-PR01-52-37/20 Item-No. 0250-0128			MA01-PR01-84x80-37x1 Item-No. 0250-2341
4.1	Spacer sleeve	MA01-PR01-Huelse 4,9 Item-No. 0250-0123			MA01-PR01-Huelse 4,9 Item-No. 0250-0123
4.2	Socket screw	M5x14 / ISO 4762			M5x14 / ISO4762
4.3	Pneumatic fitting	für 6mm hose 1/8"			für 10mm hose 1/ 4"
4.4	Socket screw	M8x14 / ISO 4762			M10x14 / DIN 7984
4.5	Adjusting washer	M8			M10

Mounting instructions: Pos. 2, 4.2, 4.3 and 4.4 must be secured with a thread locker.

Order information: one Item of Position 1, 2, 3 and 4 must be ordered.

Order information: for models 84 with 300 mm stroke a MagSpring cover has to be ordered.

Overview MagSpring DUO

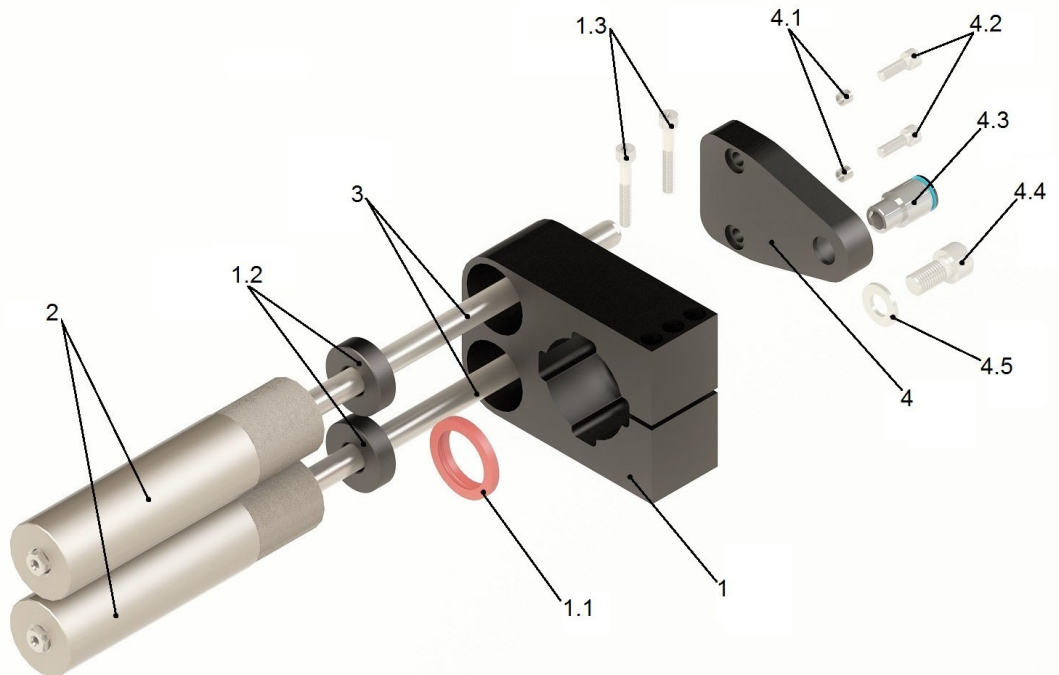

		Description / Item No. for model PR01-84 and PR01-84 -L (Not available for Linear Rotary Motors with 300mm Stroke)	
MagSpring Force		2x 60 N =120 N	
1	Multifunction flange	MF01-PR01-84x37-2 Item No. 0250-2338	
delivered with:			
1.1	Wiper	PAW01-28 Item No. 0150-3133	
1.2	Spacer washers	2x Spacer washers Item No. 0150-3133	
1.3	Socket screws	2x M5x35 / ISO 4762	
2	MagSpring Stators (2 pcs.)	100 mm Stroke	MS01-37x155; Item No. 0250-2204
		150 mm Stroke	MS01-37x170; Item No. 0250-1017
3	MagSpring Sliders (2 pcs.)	100 mm Stroke	ML01-12x350/160-20; Item No. 0250-2321
		150 mm Stroke	ML01-12x375/180-20; Item No. 0250-1070
4	MagSpring Adapter	MA01-PR01-84x80-37-2; Item No. 0250-2340	
delivered with:			
4.1	Spacer sleeves	2x MA01-PR01-Huelse 4,9 Item No. 0250-0123	
4.2	Socket screws	2x M5x14 / ISO 4762	
4.3	Pneumatic fitting	For 10 mm hose 1/ 4"	
4.4	Socket screws	M10x14 / DIN 7984	
4.5	Adjusting washer	M10	

Mounting instructions: Pos. 2, 4.2, 4.3 and 4.4 must be secured with a thread locker.

Order information: one Item of Position 1 and 4 and two Items of Position 2 and 3 must be ordered.

Overview MagSpring SYM

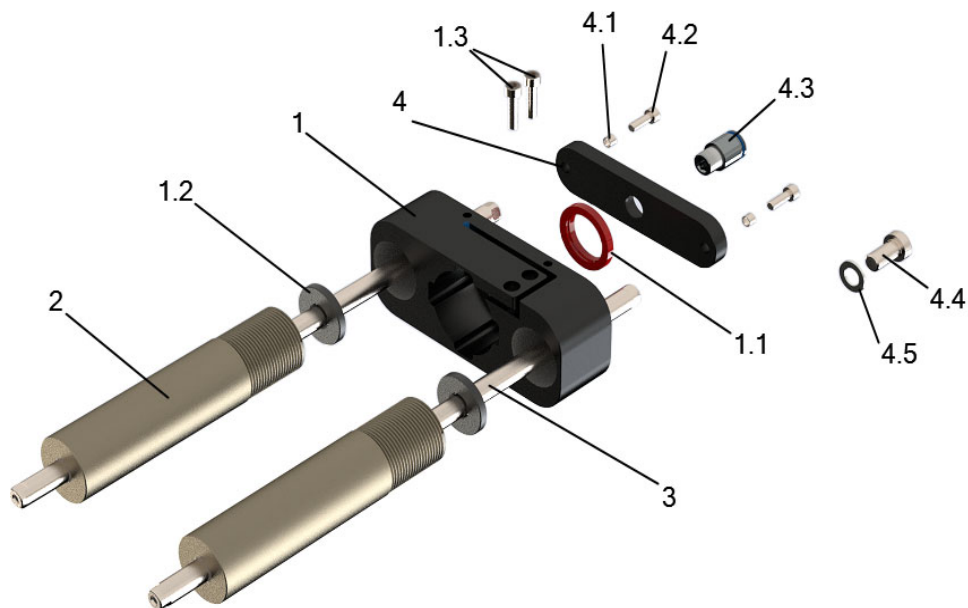

		Item / Item.-No. for Type PR01-84 and PR01-84 -L (available for Linear Rotary Motors with 300 mm Stroke)	
Magspring Force		2x 60 N = 120 N	
1	Multifunction flange	MF01-PR01-84x80-2-SYM Item.-No. 0250-2349	
1.1	Wiper	PAW01-28 Item.-No. 0150-3133	
1.2	Space washer	2x spacer washer Item.-No. 0250-0132	
1.3	Socket screws	2x M5x20 / ISO 4762	
2	MagSpring Stator (2 pcs.)	100 mm Stroke	MS01-37x155; Item.-No. 0250-2204
		150 mm Stroke	MS01-37x170 Item.-No. 0250-1017
		300 mm Stroke	MS01-37x305; Item.-No. 0250-2206
3	MagSpring Slider (2 pcs.)	100 mm Stroke	ML01-12x350/160-20; Item.-No. 0250-2321
		150 mm Stroke	ML01-12x375/180-20 Item.-No. 0250-1070
		300 mm Stroke	ML01-12x650/320-20; Item.-No. 0250-2343
4	MagSpring Adapter	MA01-PR01-84x80-37-2-SYM Item.-No. 0250-2348	
4.1	Spacer sleeve	MA01-PR01-Huelse 4,9 Art.-No. 0250-0123	
4.2	Socket screw	M5x14 / ISO 4762	
4.3	Pneumatic fitting	forr 10mm hose 1/4"	
4.4	Socket screw	M10x14 / DIN 7984	
4.5	Adjusting washer	M10	

Mounting instructions: Pos. 2, 4.2, 4.3 und 4.4 must be secured with a thread locker.

Order information: one Item of Position 1 und 4 and two Items of Position 2 und 3 must be ordered.

Order information: for models 84 with 300 mm stroke a MagSpring cover has to be ordered.

Overview Brake-Kit

Brake-Kit

For application with a pneumatic holding brake, one brake kit is available for each model (inkl. pneumatic brake).

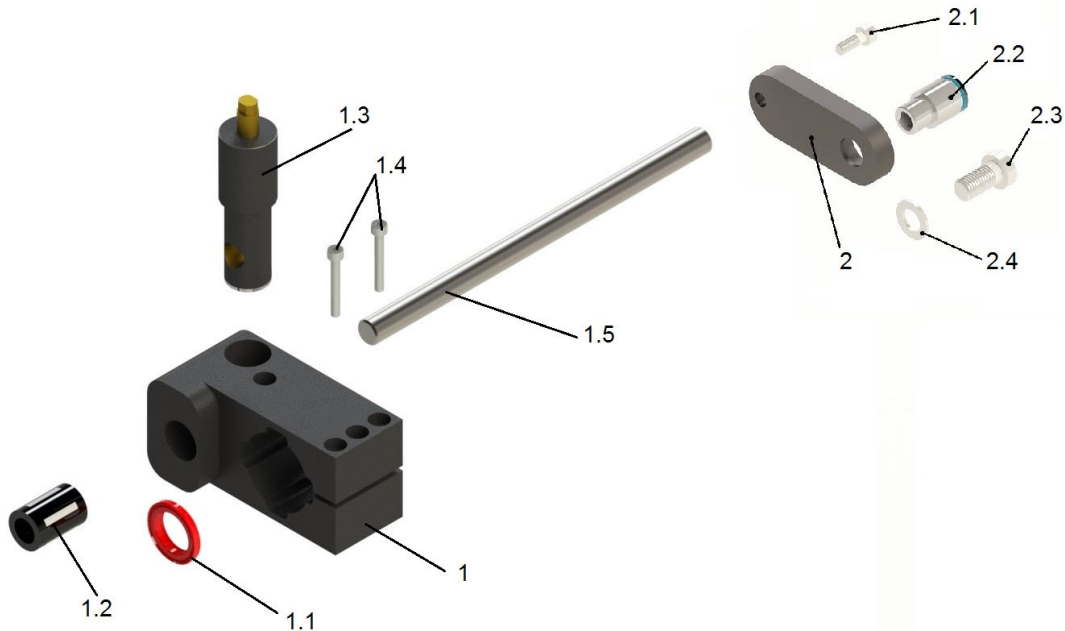

		Description / Item No. for model PR01-52 and PR01-52 -L	Description / Item No. for model PR01-84 and PR01-84 -L
1	Brake-Kit	MF01-BK52 Item No. 0250-2344	MF01-BK84 Item No. 0250-2347
delivered with:			
1.1	Wiper	PAW01-20 Item No. 0150-3112	PAW01-28 Item No. 0150-3133
1.2	Linear ball bearing	LBBR 12-2LS Item No. 0230-0062	LBBR 12-2LS Item No. 0230-0062
1.3	Pneumatic brake	HB01-37 Art.-Nr. 0150-5052	HB01-37 Art.-Nr. 0150-5052
1.4	Socket screws	2x M5x30 / ISO 4762	2x M5x35 / ISO 4762
1.5	Guiding rod	MF01k-KS12x215 Length 215 mm Item No. 0260-0174	MF01k-KS12x215 Length 215 mm Item No. 0260-0174
2	Adapter	MA01-PR01-52-37/20 Item No. 0250-0128	MA01-PR01-84x80-37-1 Item No. 0250-2341
delivered with:			
2.1	Socket screw	M5x14 / ISO 4762	M5x14 / ISO 4762
2.2	Pneumatic fitting	for 6 mm hose 1/8"	for 10 mm hose 1/4"
2.3	Socket screw	M8x14 / ISO 4762	M10x14 / DIN 7984
2.4	Adjusting washer	M8	M10

Mounting instructions: Pos. 2.1, 2.2 and 2.3 must be secured with a thread locker.

Order information: one Item of Position 1 and 2 must be ordered

Flanges dimensions

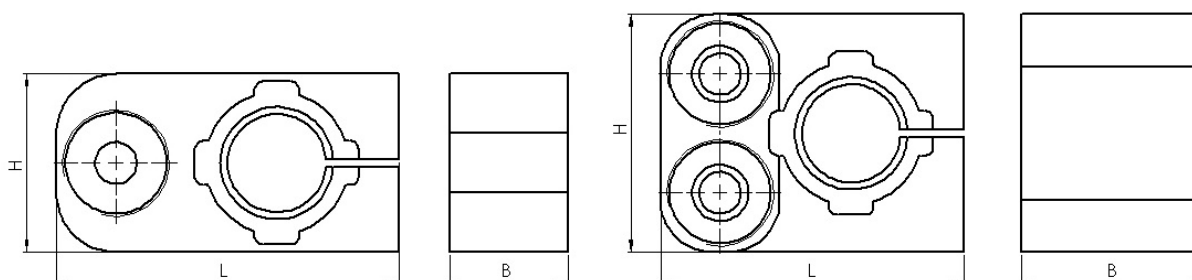
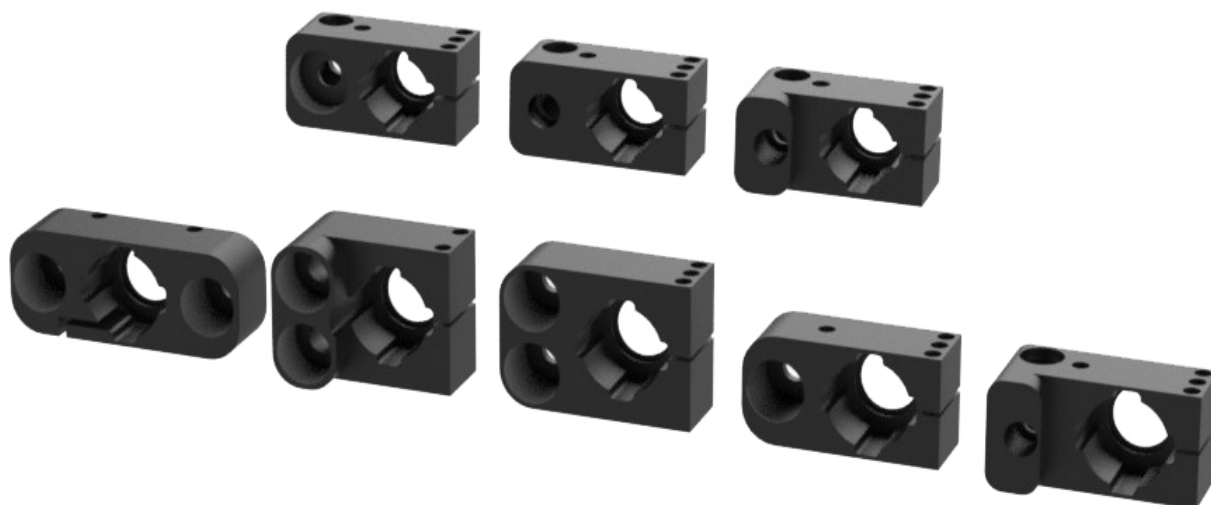

	Material: Al anodized	Description	Item No.	L	B	H	Mass
1	Multifunction flange for model PR01-52	MF01-PR01-52x40-20	0250-2322	100 mm	40 mm	50 mm	0.33 kg
2	Multifunction flange for model PR01-52	MF01-PR01-52x40-37	0250-2319	100 mm	40 mm	50 mm	0.31 kg
3	Multifunction flange for model PR01-84	MF01-PR01-84x80-37-1	0250-2337	115 mm	40 mm	60 mm	0.425 kg
4	Multifunction flange for model PR01-84	MF01-PR01-84x80-37-2	0230-2338	115 mm	40 mm	80 mm	0.590 kg
5	SYM Multifunction flange for model PR01-84	MF01-PR01-84x80-37-2-SYM	0250-2349	148 mm	40 mm	60 mm	0.848 kg
6	Brake-Kit PR01-flange	MF01-BK52	0250-2344	100 mm	52 mm	50 mm	0.365 kg
7	Brake-Kit PR01-flange	MF01-BK84	0250-2347	115 mm	55 mm	60 mm	0.501 kg

Adapters dimensions

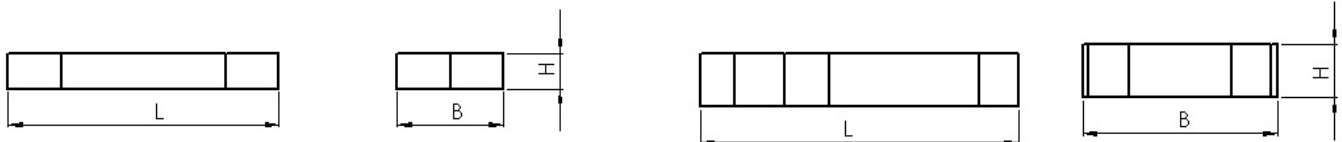

	Material: Al anodized	Description	Item No.	L	B	H	Mass
1	Adapter for model PR01-52	MA01-PR01-52x37/20	0250-0128	65 mm	22 mm	10 mm	0.05 kg
2	Adapter for model PR01-84	MA01-PR01-84x80-37-1	0250-2341	76.5 mm	30 mm	10 mm	0.085 kg
3	Adapter for model PR01-84	MA01-PR01-84x80-37-2	0250-2340	90 mm	55 mm	15 mm	0.186 kg
4	SYM Adapter for model PR01-84	MA01-PR01-84x80-37-2-SYM	0250-2348	125 mm	30 mm	10 mm	0.499 kg

Cam Kit MF01-PK84

Usage of cam kit

For the application as an emergency crank a pulley (not included) can be mounted at the side of an adapter (thread M10). In combination with a splitter, a forced movement in a linear direction can be achieved.

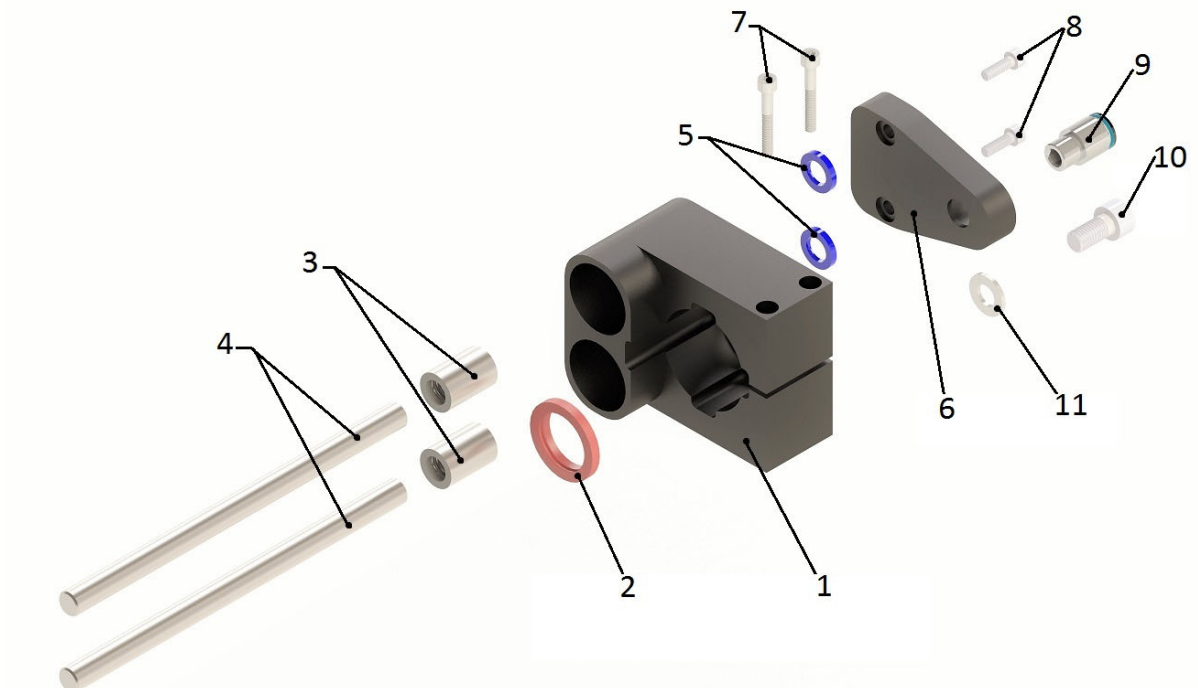

Order information: 0250-2324 Cam Kit MF01-PK84 (consisting of 1 – 11)

		Description / Item No. for MF01-PK84 Item No. 0250-2324
1	Cam flange	MF01k-PR01-84x80-K Item No. 0260-0151
2	Wiper	PAW01-28 Art.-No. 0150-3133
3	Linear ball bearings	2x LBBR 12-2LS Item No. 0230-0062
4	Guiding rods	2x MF01k-KS12x200 Length 200 mm Item No. 0260-0134
5	Shaft seals	2x SP-12x19x3 Item No. 0260-0150
6	Cam Kit adapter	MA01k-PR01-84x80-K Item No. 0250-0130
7	Socket crews	2x M5x35 / ISO 4762
8	Socket screws	2x M5x14 / ISO4 762
9	Pneumatic fitting	for 10 mm hose 1/ 4"
10	Socket screw	M10x14 / DIN 7984
11	Adjusting washer	M10

Mounting instructions: Pos. 8, 9 and 10 must be secured with a thread locker.

Dimensions Cam flange

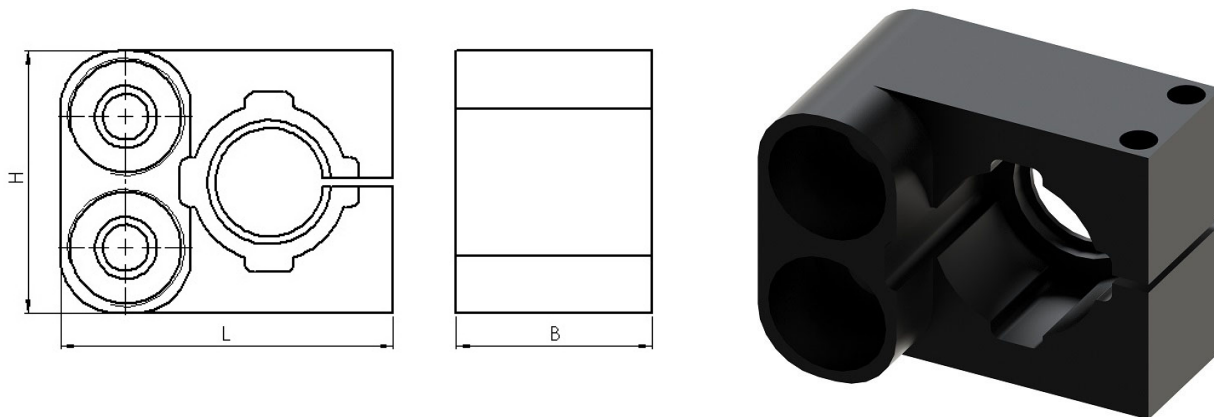

Material: Al anodized	L	B	H	Mass
Cam flange – individual Item	102 mm	60 mm	80 mm	0.610 kg

Dimensions Cam adapter

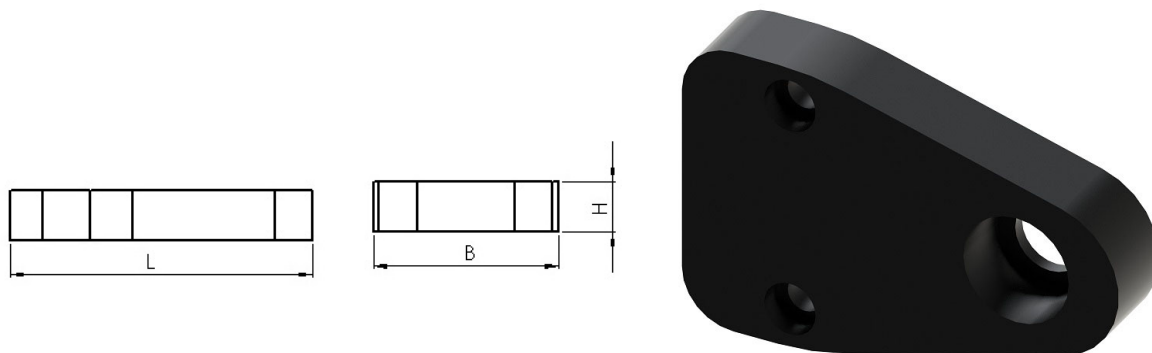

Material: Al anodized	L	B	H	Mass
Cam adapter – individual Item	85 mm	55 mm	12 mm	0.125 kg

MagSpring Cover (only for model PR01-84 with 300 mm stroke)

Application

The cover is used for the Linear Rotary Motors PR01-84x with 300 mm stroke as a protection for long MagSpring slider

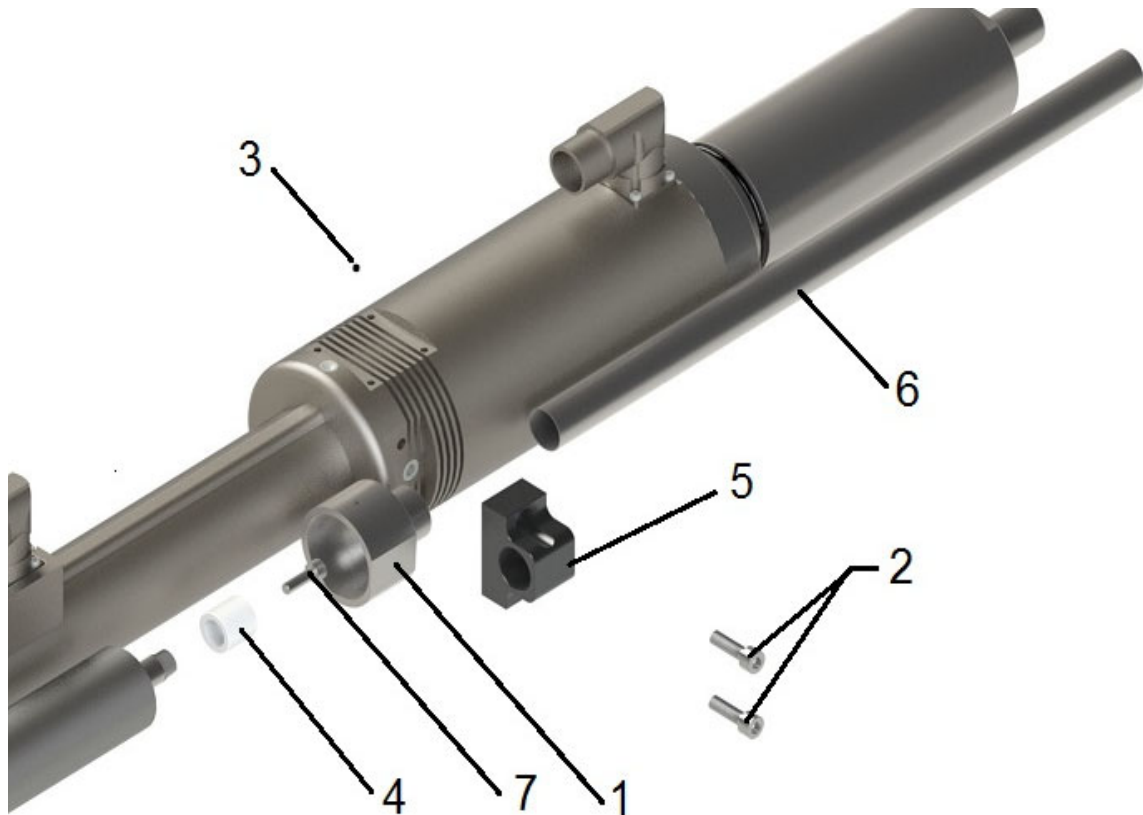

Order information: 0250-2345 MagSpring cover ML01-AS300 (consisting of 1 – 7)

		Description / Item No. for ML01-AS300 Item No. 0250-2345
1	Extension flange	MS01k-EF37 Item No. 0260-0154
2	Socket screws	2x M6x16 / ISO 4762
3	Hex socket set screw with cone point	1x M3x3 / ISO 4027
4	Plain bearing for ML01-12	ML01k-GL17.9x17 Item No. 0260-0155
5	Spacer	ML01k-DF37 Item No. 0260-0156
6	Cover tube	ML01k-AR19x350 Item No. 0260-0157
7	Socket screw	1x M5x14 / ISO 4762

Magnetic spring MagSpring®

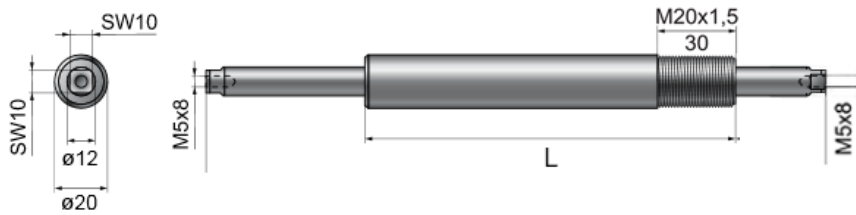

Dimensions MagSpring Stator MS01-20x140

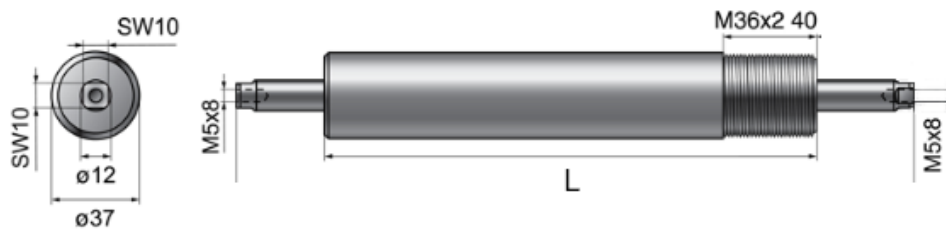

Dimensions MagSpring Stator MS01-37x155

MagSpring Stator	Force (depending on slider)	Article	Item No.	L	D	Mass
Model PR01-52	22 N	MS01-20x140	0250-2201	140 mm	20 mm	0.18 kg
Model PR01-52	40N / 60 N	MS01-37x155	0250-2204	155 mm	37 mm	0.88 kg
Model PR01-52	40N / 60 N	MS01-37x170	0250-1017	170 mm	37 mm	0.96 kg
Model 84 100 mm Stroke	60 N	MS01-37x155	0250-2204	155 mm	37 mm	0.88 kg
Model 84 150 mm Stroke	60 N	MS01-37x170	0250-1017	170 mm	37 mm	0.96 kg
Model PR01-84 300 mm stroke	60 N	MS01-37x305	0250-2206	305 mm	37 mm	1.73 kg

MagSpring Slider	Force	Article	Item No.	L	D	Mass
Model PR01-52	22 N	ML01-12x350/160-20	0250-2321	350 mm	12 mm	0.173 kg
Model PR01-52 Stroke 80 – 100 mm	40 N	ML01-12x350/160-10	0250-2333	350 mm	12 mm	0.175 kg
Model PR01-52 Stroke 150 mm	40 N	ML01-12x375/160-10	0250-1023	375 mm	12 mm	0.2 kg
Model PR01-52 Stroke 80 – 100 mm	60 N	ML01-12x350/160-20	0250-2321	350 mm	12 mm	0.173 kg
Model PR01-52 Stroke 150 mm	60 N	ML01-12x375/160-20	0250-2326	375 mm	12 mm	0.2 kg
Model PR01-84 100 / 150 mm stroke	60 N	ML01-12x350/160-20	0250-2321	350 mm	12 mm	0.175 kg
Model PR01-84 300 mm stroke	60 N	ML01-12x650/320-20	0250-2343	650 mm	12 mm	0.321 kg

Examples:

Linear Rotary Motor model PR01-52 with 40N MagSpring:

Stator: MS01-37x155
Slider: ML01-12x350/160-10

Linear Rotary Motor model PR01-84 with 60N MagSpring:

Stator: MS01-37x155
Slider: ML01-12x350/160-20

Accessories Overview

MagSpring accessories for all PR01-52 models with 80 mm and 100 mm stroke

Force 22N		Force 40N		Force 60N	
Item No.	Description	Item No.	Description	Item No.	Description
0250-0128	MA01-PR01-52-37/20	0250-0128	MA01-PR01-52-37/20	0250-0128	MA01-PR01-52-37/20
0250-2322	MF01-PR01-52x40-20	0250-2319	MF01-PR01-52x40-37	0250-2319	MF01-PR01-52x40-37
0250-2201	MS01-20x140	0250-2204	MS01-37x155	0250-2204	MS01-37x155
0250-2321	ML01-12x350/160-20	0250-2333	ML01-12x350/160-10	0250-2321	ML01-12x350/160-20

MagSpring accessories for all PR01-52 models with 150 mm stroke

Force 22N		Force 40N		Force 60N	
Item No.	Description	Item No.	Description	Item No.	Description
0250-0128	MA01-PR01-52x40-37/20	0250-0128	MA01-PR01-52x40-37/20	0250-0128	MA01-PR01-52x40-37/20
0250-2322	MF01-PR01-52x40-20	0250-2319	MF01-PR01-52x40-37	0250-2319	MF01-PR01-52x40-37
0250-2201	MS01-20x140	0250-1017	MS01-37x170	0250-1017	MS01-37x170
0250-2321	ML01-12x350/160-20	0250-1023	ML01-12x375/160-10	0250-2326	ML01-12x375/160-20

MagSpring accessories for all PR01-84 models with 100 mm

Force 60N		Force 100N (side)		Force 120N (side)	
Item No.	Description	Item No.	Description	Item No.	Description
0250-2340	MA01-PR01-84x37-1	0250-2340	MA01-PR01-84x80-37-2	0250-2340	MA01-PR01-84x80-37-2
0250-2337	MF01-PR01-84x37-1	0250-2338	MF01-PR01-84x37-2	0250-2338	MF01-PR01-84x37-2
0250-2204	MS01-37x155	2x 0250-2204	MS01-37x155	2x 0250-2204	MS01-37x155
0250-2321	ML01-12x350/160-20	0250-2321	ML01-12x350/160-20	2x 0250-2321	ML01-12x350/160-20
		0250-2333	ML01-12x350/160-10		

Force 100 N (symmetric)		Force 120 N (symmetric)	
Item No.	Description	Item No.	Description
0250-2348	MA01-PR01-84x80-37-2-SYM	0250-2348	MA01-PR01-84x80-37-2-SYM
0250-2349	MF01-PR01-84x80-37-2-SYM	0250-2349	MF01-PR01-84x80-37-2-SYM
2x 0250-2204	MS01-37x155	2x 0250-2204	MS01-37x155
0250-2321	ML01-12x350/160-20	2x 0250-2321	ML01-12x350/160-20
0250-2333	ML01-12x350/160-10		

MagSpring accessories for all PR01-84 models with 150 mm

Force 60N		Force 100N (Seite)		Force 120N (Seite)	
Item No.	Description	Item No.	Description	Item No.	Description
0250-2340	MA01-PR01-84x80-37-1	0250-2340	MA01-PR01-84x80-37-2	0250-2340	MA01-PR01-84x80-37-2
0250-2337	MF01-PR01-84x80-37-1	0250-2338	MF01-PR01-84x80-37-2	0250-2338	MF01-PR01-84x80-37-2
0250-1017	MS01-37x170	2x 0250-1017	MS01-37x170	2x 0250-1017	MS01-37x170
0250-1070	ML01-12x375/180-20	0250-1070	ML01-12x375/180-20	2x 0250-1070	ML01-12x375/180-20
		0250-1023	ML01-12x375/160-10		

Force 100 N (symmetric)		Force 120 N (symmetric)	
Art.-Nr.	Artikel	Art.-Nr.	Artikel
0250-2348	MA01-PR01-84x80-37-2-SYM	0250-2348	MA01-PR01-84x80-37-2-SYM
0250-2349	MF01-PR01-84x80-37-2-SYM	0250-2349	MF01-PR01-84x80-37-2-SYM
2x 0250-1017	MS01-37x170	2x 0250-1017	MS01-37x170
0250-1070	ML01-12x375/180-20	2x 0250-1070	ML01-12x375/180-20
0250-1023	ML01-12x375/160-10		

MagSpring accessories for all PR01-84 models with 300 mm stroke

Force 60N		Force 120 N	
Item No.	Description	Item No.	Description
0250-2341	MA01-PR01-84x80-37-1	0250-2348	MA01-PR01-84x80-37-2-SYM
0250-2337	MF01-PR01-84x80-37-1	0250-2349	MF01-PR01-84x80-37-2-SYM
0250-2206	MS01-37x305	2x 0250-2206	MS01-37x305
0250-2343	ML01-12x650/320-20	2x 0250-2343	ML01-12x650/320-20
0250-2345	ML01-AS300	2x 0250-2345	ML01-AS300

Brake-Kit for all PR01-52 models

Art.-Nr.	Artikel
0250-0128	MA01-PR01-52x-37/20
0250-2344	MF01-BK52

Brake-Kit for all PR01-84 Models with 100 mm and 150 mm stroke

Art.-Nr.	Artikel
0250-2341	MA01-PR01-84x80-37-1
0250-2347	MF01-BK84

Cam-Kit for all PR01-84 Models with 100 mm and 150 mm stroke

Cam-Kit	
Item No.	Description
0250-2324	MF01-PK84

NOTE: Other accessories, such as ventilators, load attachments, flanges, heat sinks, etc. can be ordered in addition.

Order examples

Example 1: Linear Rotary Motor PR01-52x with hollow Shaft, 80 mm stroke and 40N MagSpring, assembled on right side, pulling direction force (see page 39)

pcs	Description	Item No.	Comment
1	PR01-52x40-R/37x120F-HP-C-80-L	0150-2703	Linear Rotary Motor with hollow Shaft
1	PC01-37x68	0160-2131	Heat sink, see page 34
1	MA01-PR01-52-37/20	0250-0128	MagSpring Adapter
1	MF01-PR01-52x40-37	0250-2319	Multifunction Flange
1	MS01-37x155	0250-2204	MagSpring Stator
1	ML01-12x350/160-10	0250-2333	MagSpring Slider
1	Linear Rotary Motor Accessories orientation: right	0140-0002	Assembly instructions, see page 39
1	Linear Rotary Motor MagSpring force direction: pull	0140-0006	Assembly instructions, see page 39

Example 2: Linear Rotary Motor PR01-84x Stainless Steel with hollow Shaft, 150 mm stroke and 120N MagSpring accessories, assembled on left side, pushing direction force (see page 39)

pcs	Description	Item No.	Comment
1	PR01-84x80-SSC-C/48x240F-C-150-L	0150-1582	Linear Rotary Motor, Stainless Steel
2	PC01-48x117	01560-2138	Heat sinks, see page 34
1	MA01-PR01-84x80-37-2	0250-2340	MagSpring Adapter
1	MF01-PR01-84x37-2	0250-2338	Multifunction Flange
1	MS01-37x170	2x 0250-1017	MagSpring Stator
1	ML01-12x375/180-20	2x 0250-1070	MagSpring Slider
1	Linear Rotary Motor Accessories orientation: left	0140-0004	Assembly instructions, see page 39
1	Linear Rotary Motor MagSpring force direction: push	0140-0005	Assembly instructions, see page 39

Example 3: Linear Rotary Motor PR01-84x with Gearbox 7:1, 150 mm stroke, Heat sinks and Cam-Kit, not assembled

pcs	Description	Item No.	Comment
1	PR01-84x80-C-G/48x360F-C-150-G07	0150-2536	Linear Rotary Motor with gearbox 7:1
3	PC01-48x100	0160-2145	Heat sinks, see page 34
1	MF01-PK84	0250-2340	Linear Rotary Motor Cam Kit

Example 4: Linear Rotary Motor PR01-52x, 100 mm stroke and Brake-Kit, assembled on the left side

Stk.	Artikel	Art.-Nr.	Bemerkung
1	PR01-52x60-R/37x120F-HP-C-100	0150-1197	Linear Rotary Motor
1	MA01-PR01-52-37/20	0250-0128	Mounting Adapter for Linear Rotary Motor
1	MF01-BK52	0250-2344	Brake-Kit flange Linear Rotary Motor for PR01-52
1	Linear Rotary Motor Accessories orientation: left	0140-0004	Assembly instructions, see page 39

Example 5: Linear Rotary Motor PR01-84x, 150 mm stroke and 120N symmetric MagSpring not assembled

Stk.	Artikel	Art.-Nr.	Bemerkung
1	PR01-84x80-SSC-C/48x240F-C-150-L	0150-1582	Linear Rotary Motor INOX
1	MA01-PR01-84x80-37-2-SYM	0250-2348	MagSpring Adapter
1	MF01-PR01-84x80-37-2-SYM	0250-2349	Multifunction Flange
2	MS01-37x170	2x 0250-1017	MagSpring Stator
2	ML01-12x375/180-20	2x 0250-1070	MagSpring Slider

Example 6: Linear Rotary Motor PR01-84x, 300 mm stroke and 120N symmetric MagSpring, assembled

Stk.	Artikel	Art.-Nr.	Bemerkung
1	PR01-84x80-C/48x240F-C-300	0150-1580	Linear Rotary Motor, 300 mm Stroke
1	MA01-PR01-84x80-37-2-SYM	0250-2348	MagSpring Adapter
1	MF01-PR01-84x80-37-2-SYM	0250-2349	Multifunction Flange
2	MS01-37x305	2x 0250-2206	MagSpring Stator
2	ML01-12x650/320-20	2x 0250-2343	MagSpring Slider
2	ML01-AS300	2x 0250-2345	MagSpring cover for 300 mm stroke MagSpring
1	Linear Rotary Motor MagSpring force direction: pull	0140-0006	Assembly instructions, see page 39

Load attachment

Because both a rotary and a linear motion are performed, the type of attachment must be selected such that it can support both torques and longitudinal forces.

Clamp sets that enable fast, easy mounting of the load Mass are available as accessories. They provide a force-fit connection that is created by two conical rings. This completely eliminates the need for inserting lugs or producing grooves.

RS01-SS12x22 Clamp set for model 52

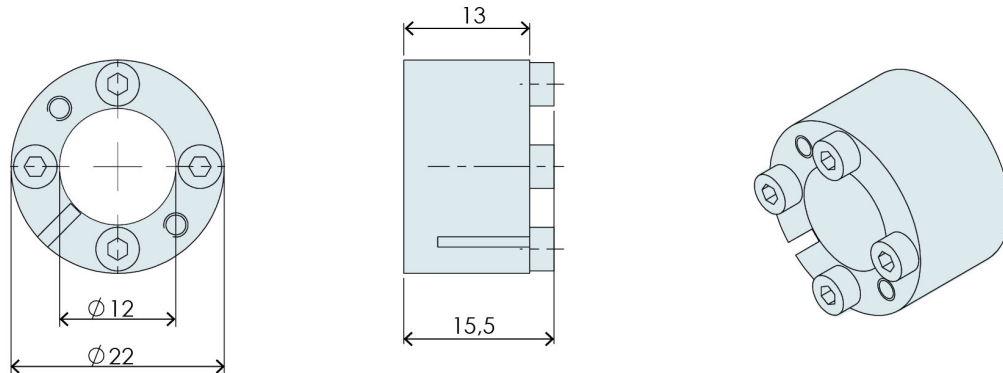

RS01-SS12x38 Clamp set for model 84

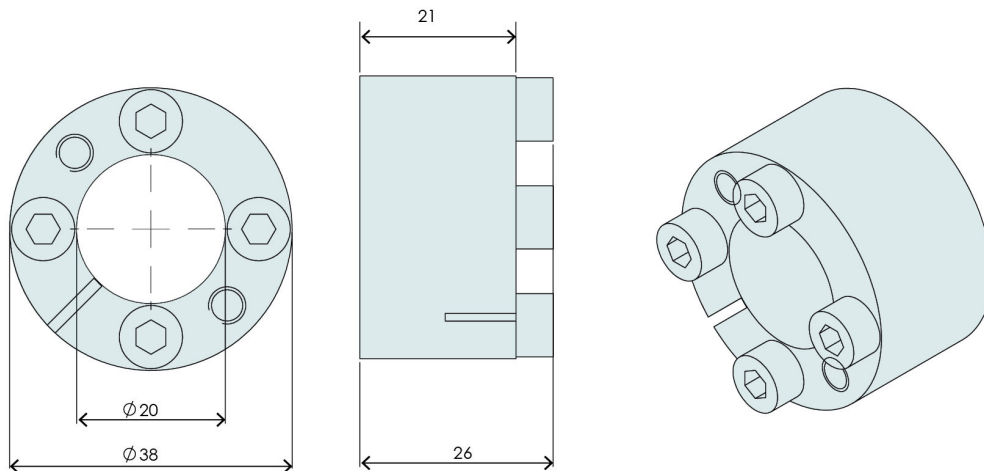

Technical data and mounting instruction

Artikel	Art- No.	T	F _{ax}	T _A	D	Mass
RS01-SS12x22	0230-0101	24 Nm	4 kN	1.2 Nm	22H9 mm	22 g
RS01-SS20x38	0230-0100	179 Nm	17 kN	10 Nm	38H9 mm	100 g

T = transmittable torque at F_{ax} = 0.

F_{ax} = transmittable axial force at T = 0.

T_A = fastening torque of the screws.

D = external exposure tolerance.

Mounting: The locking assembly has to sit inside the bore by at least the clamp length (13 mm, resp. 21 mm). Slightly oil the locking assembly before mounting, do not use molybdenum disulphide or fat. Tighten the screws evenly and crosswise in several steps.

Connector assignment

Connector assignment Linear Motors

Stecker Typ	C-Connector
	Pin
Phase 1+	A
Phase 1-	B
Phase 2+	C
Phase 2-	D
+5V	E
GROand*	F
Sensor Sinus	G
Sensor Cosinus	H
Temp. Sensor	L
Shield*	Casing

Connector assignment Rotary Motors

Stecker Typ	C-Connector	R-Connector
	Pin	Pin
Phase A	A	1
Phase B	B	2
Phase C	C	3
NC	D	4 (not connected)
+5V	E	A
GROand*	F	B
Sensor Sinus	G	C
Sensor Cosinus	H	D
Temp. Sensor	L	E
Schirm*	Gehäuse	Gehäuse

Extension cables are double shielded. The two shields of the extension cables must not be connected together: The inner shield of the extension cables is used as GROand and must be connected to GROand*, only the outer shield must be connected to SHIELD* of the connectors.

Caution: Do not connect or disconnect motor when there is power on the controller.
 Double-check each connection!
 Wrong connections can destroy controller and stator!



Stroke range PR01-52x40-R/37x120F-HP-C-80

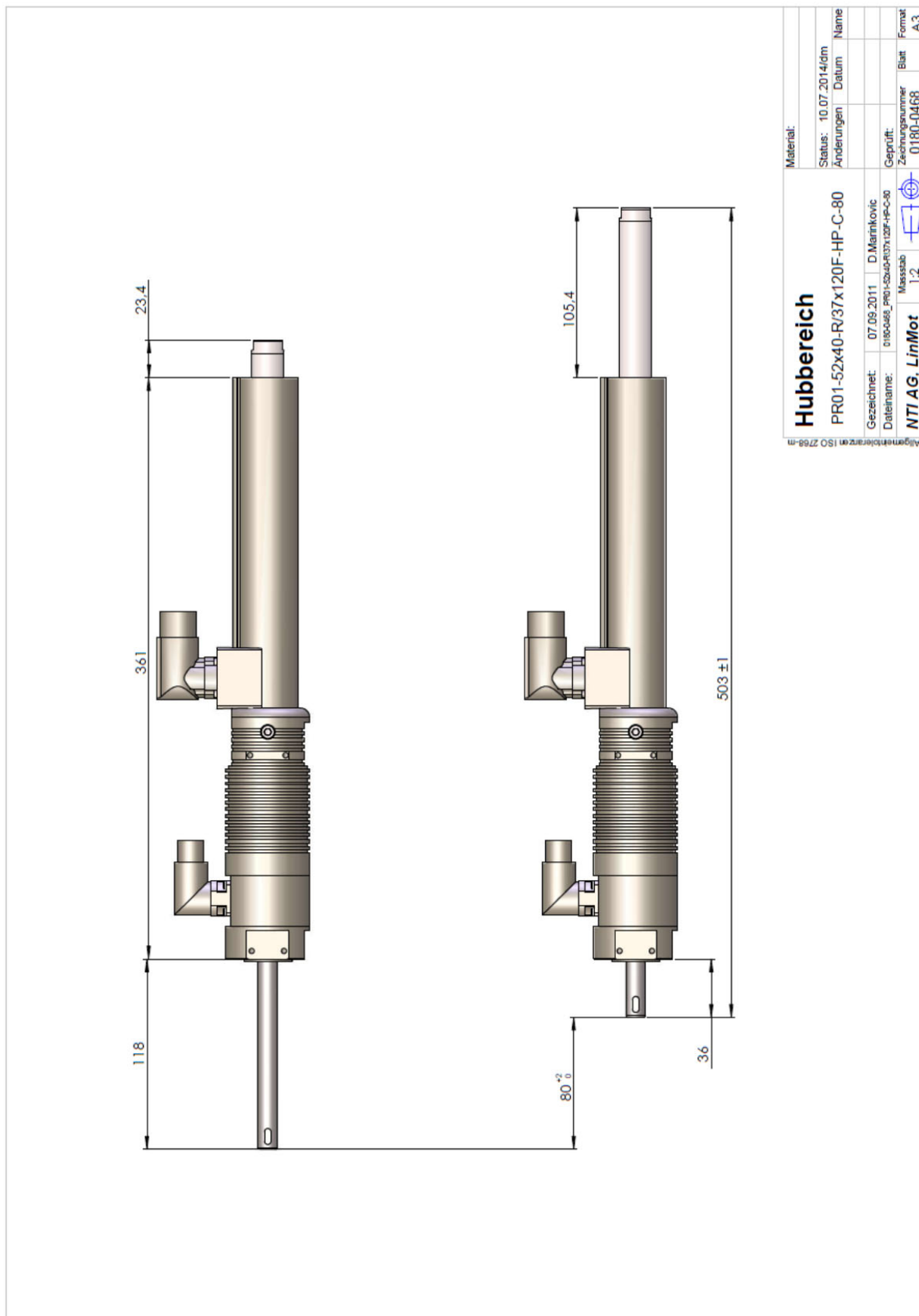

Drawing PR01-52x60-R/37x120F-HP-C-100

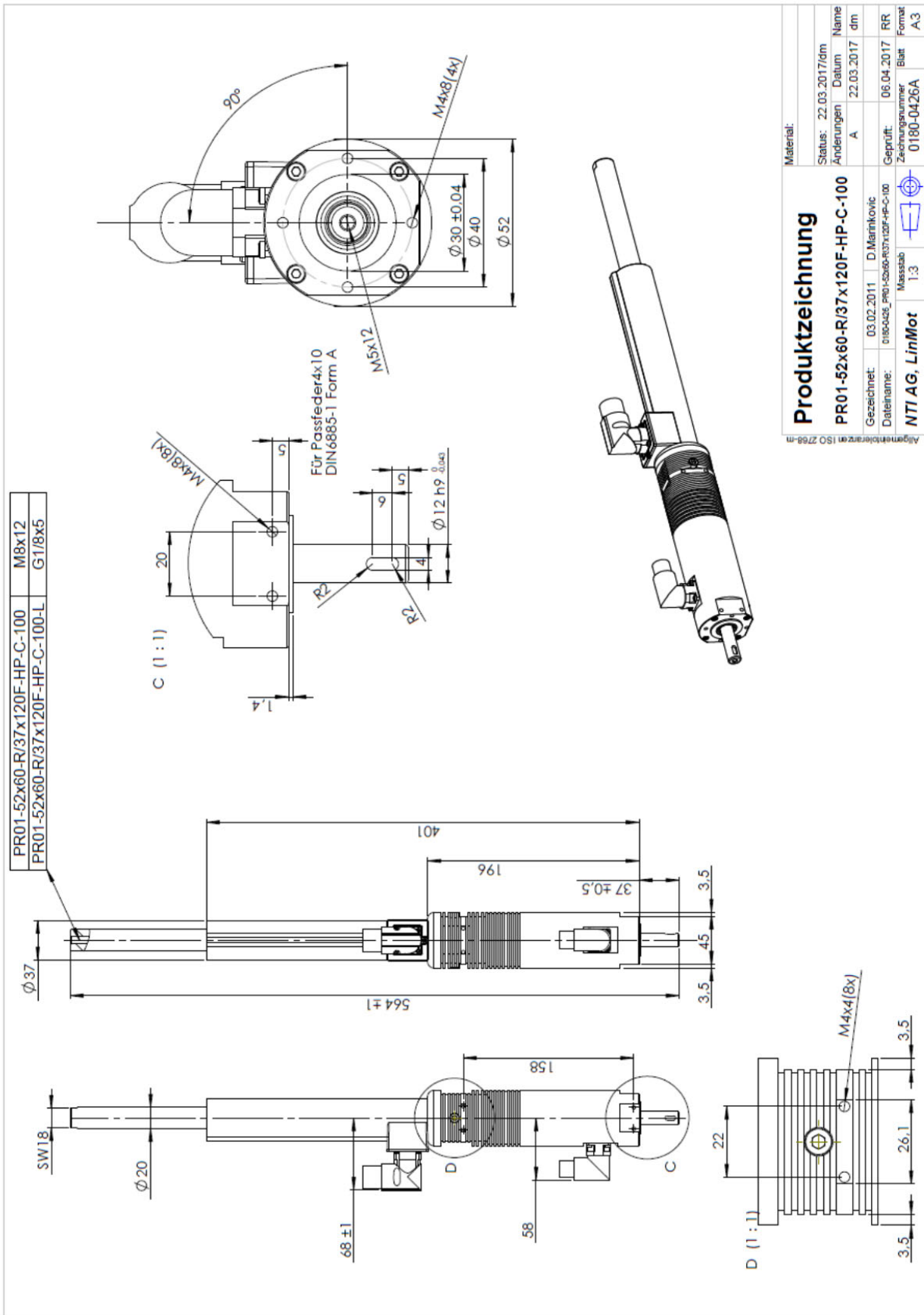

Stroke range PR01-52x60-R/37x120F-HP-C-100

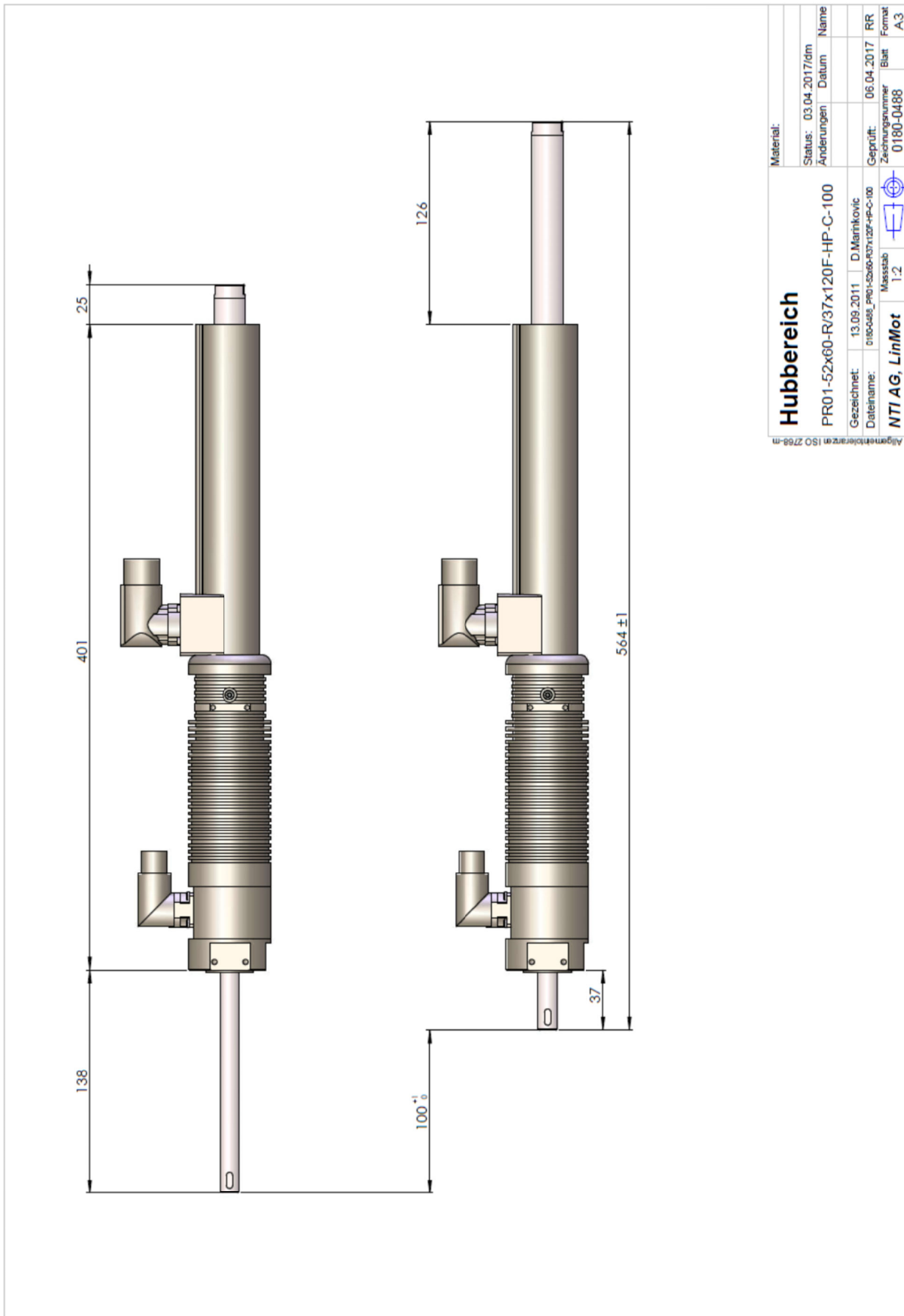

Drawing PR01-52x60-R/37x120F-HP-C-100 with Flange PF02-37x100

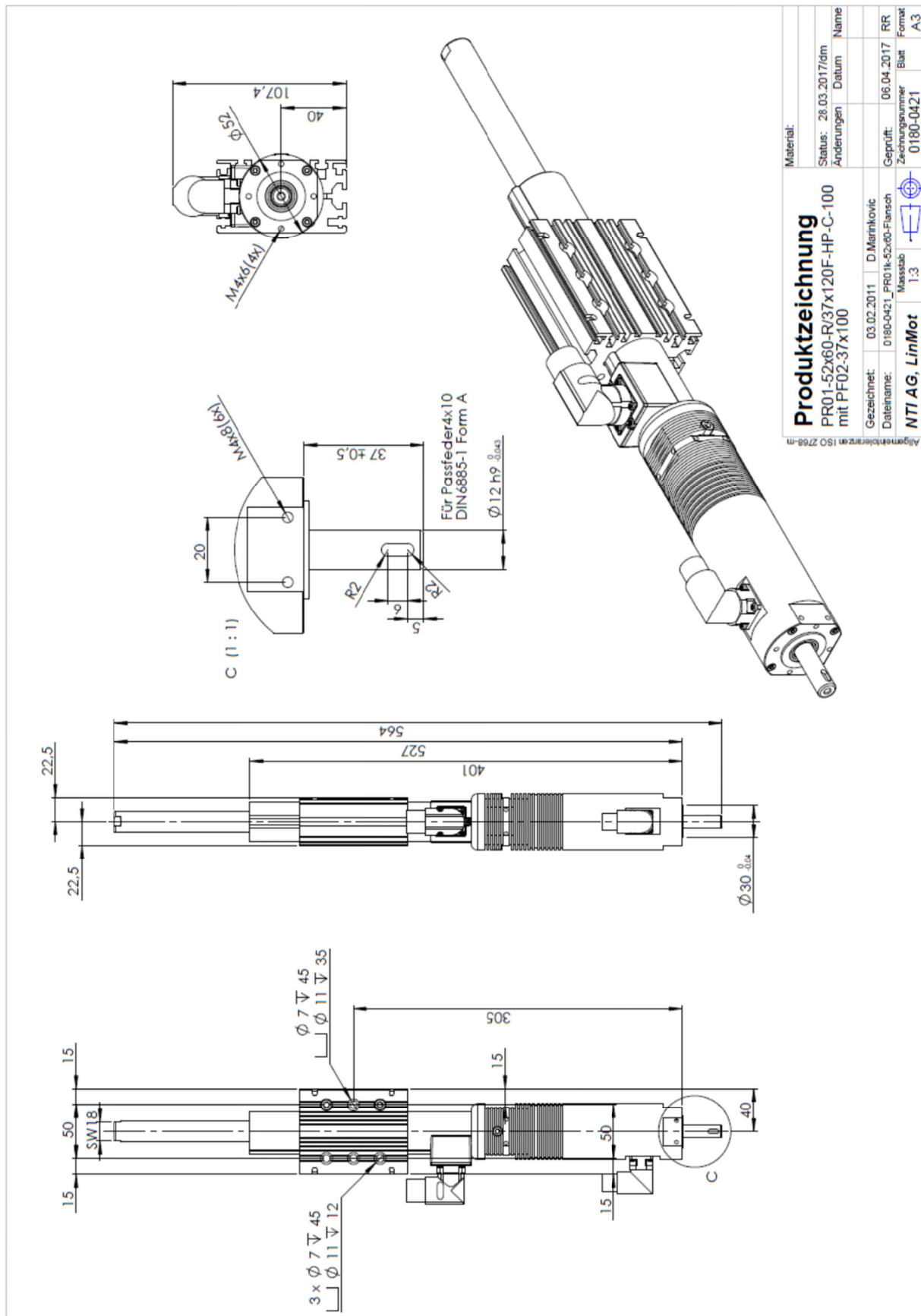

Drawing PR01-52x60-R/37x120F-HP-C-100 with MagSpring

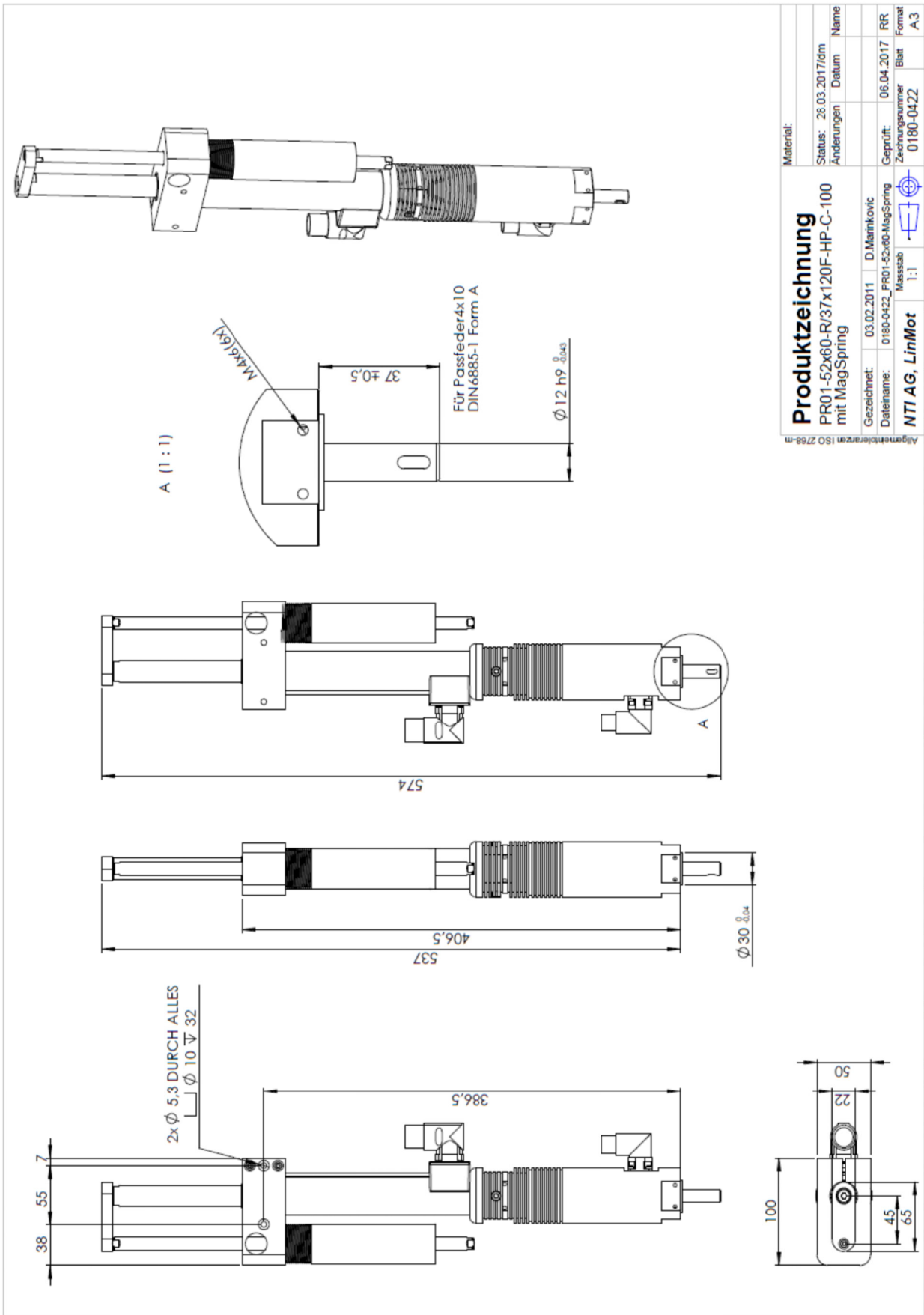

Material:		Status: 28.03.2017/dm	
Änderungen		Datum	Name
Gezeichnet: 03.02.2011		D. Marinkovic	
Dateiname: 0180-0422_PR01-52x60-MagSpring		Geprüft: 06.04.2017	RR
NTI AG, LinMot		Zeichnungsnummer	Blatt
Massstab: 1:1		0180-0422	Format: A3

Produktzeichnung
 PR01-52x60-R/37x120F-HP-C-100
 mit MagSpring

Das Urheberrecht an diesem Dokument, das dem Empfänger persönlich anvertraut wird, verbleibt unserer Firma. Ohne unsere schriftliche Genehmigung darf das Dokument weder kopiert noch vervielfältigt noch Dritten mitgeteilt oder zugänglich gemacht werden.

Drawing PR01-52x60-R/37x120F-HP-C-150

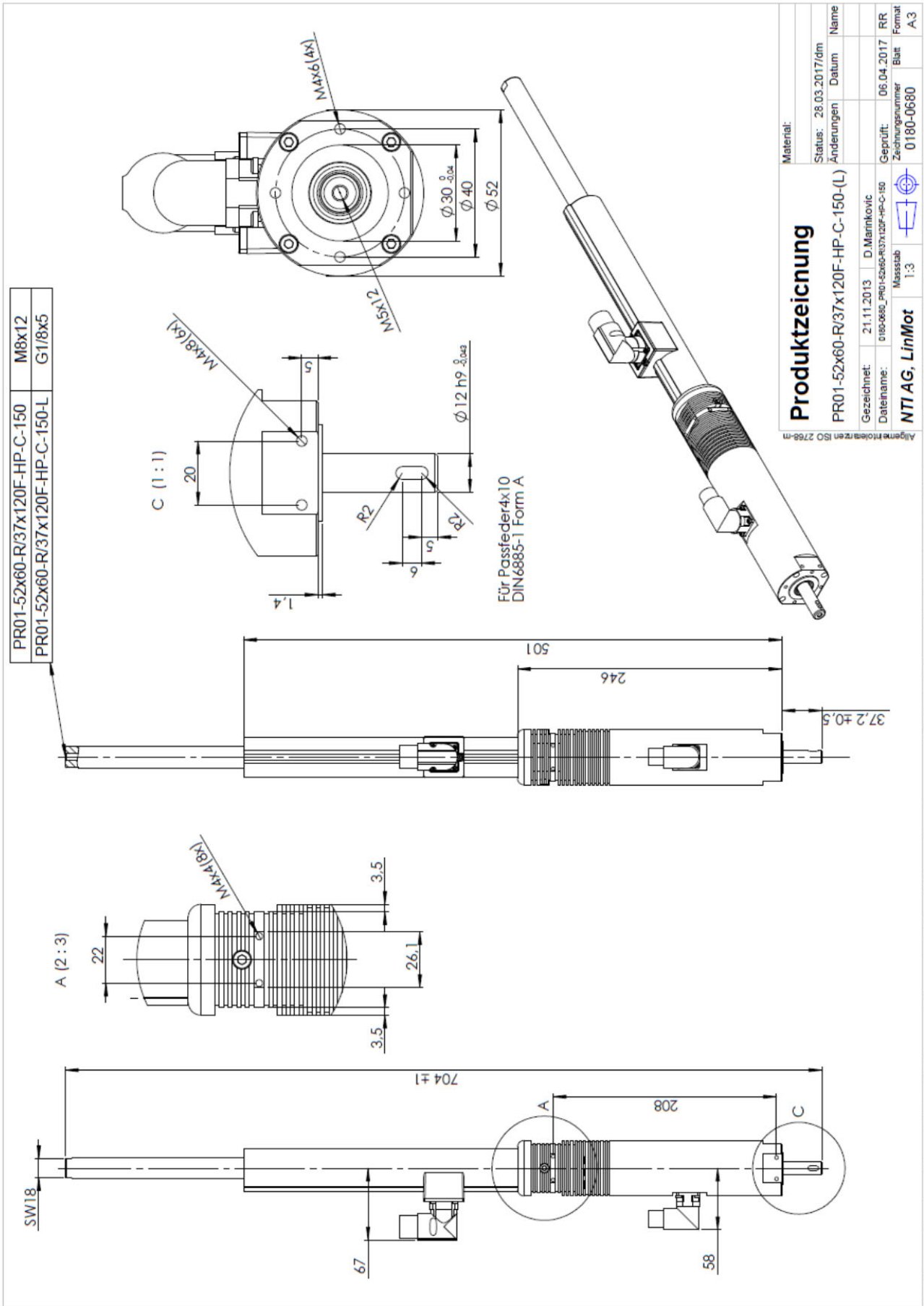

Stroke range PR01-52x60-R/37x120F-HP-C-150

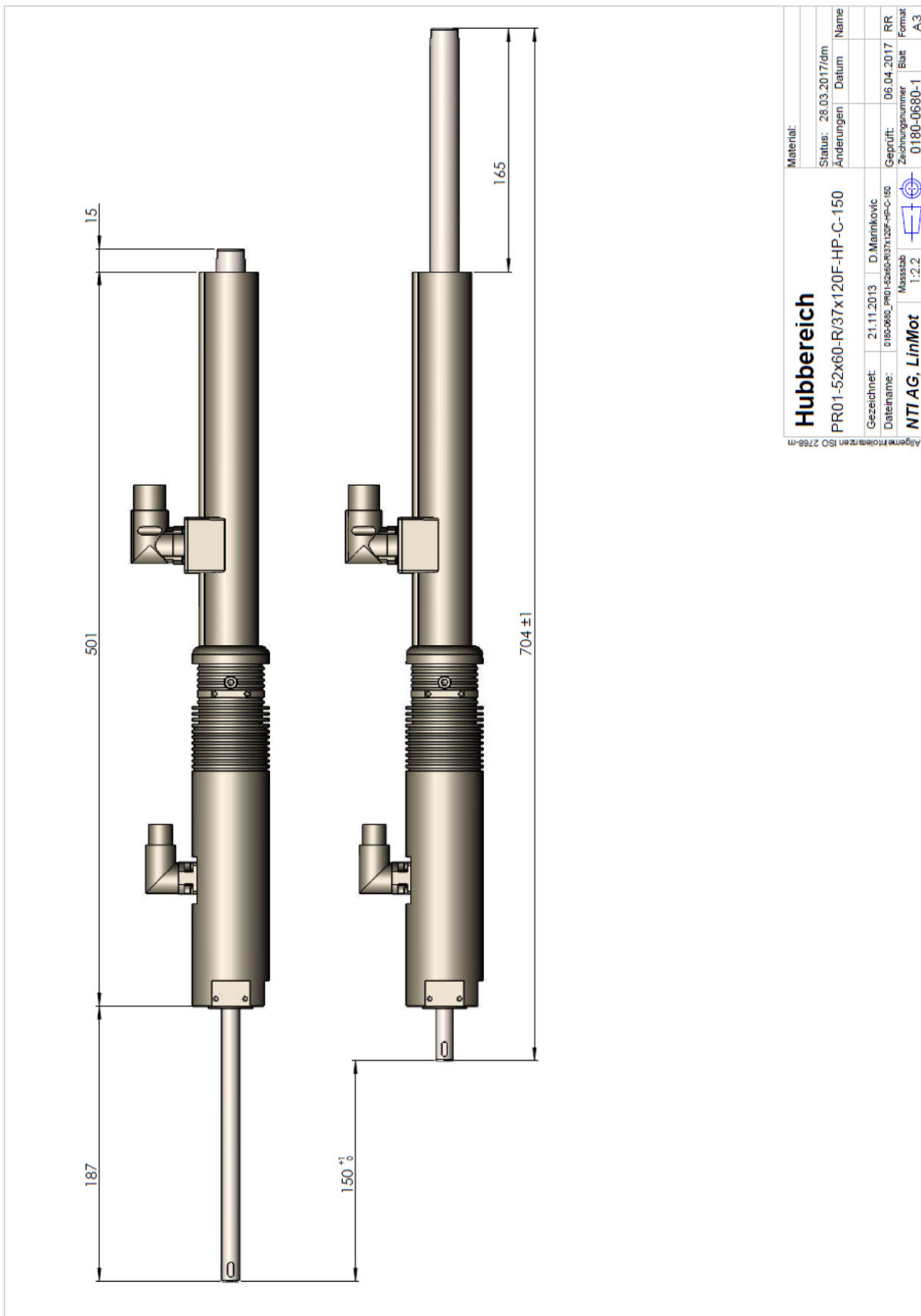

Hubbereich		Material:	
PR01-52x60-R/37x120F-HP-C-150		Status:	28.03.2017/dm
		Änderungen	Name
Gezeichnet:	21.11.2013	D. Mannkovic	
Datenname:	01800680_PR01-52x60-R/37x120F-HP-C-150	Geprüft:	06.04.2017 RR
		Zeichnungsnummer	Blatt
		0180-0680-1	A3
NTI AG, LinMot		Format	
		A3	

Das Urheberrecht an diesem Dokument, das dem Empfänger persönlich anvertraut wird, verbleibt unserer Firma. Ohne unsere schriftliche Genehmigung darf das Dokument weder kopiert noch vervielfältigt noch Dritten mitgeteilt oder zugänglich gemacht werden.

Algemeine Normen ISO 2768-m

Drawing PR01-52x60-R/37x120F-HP-C-100-G..

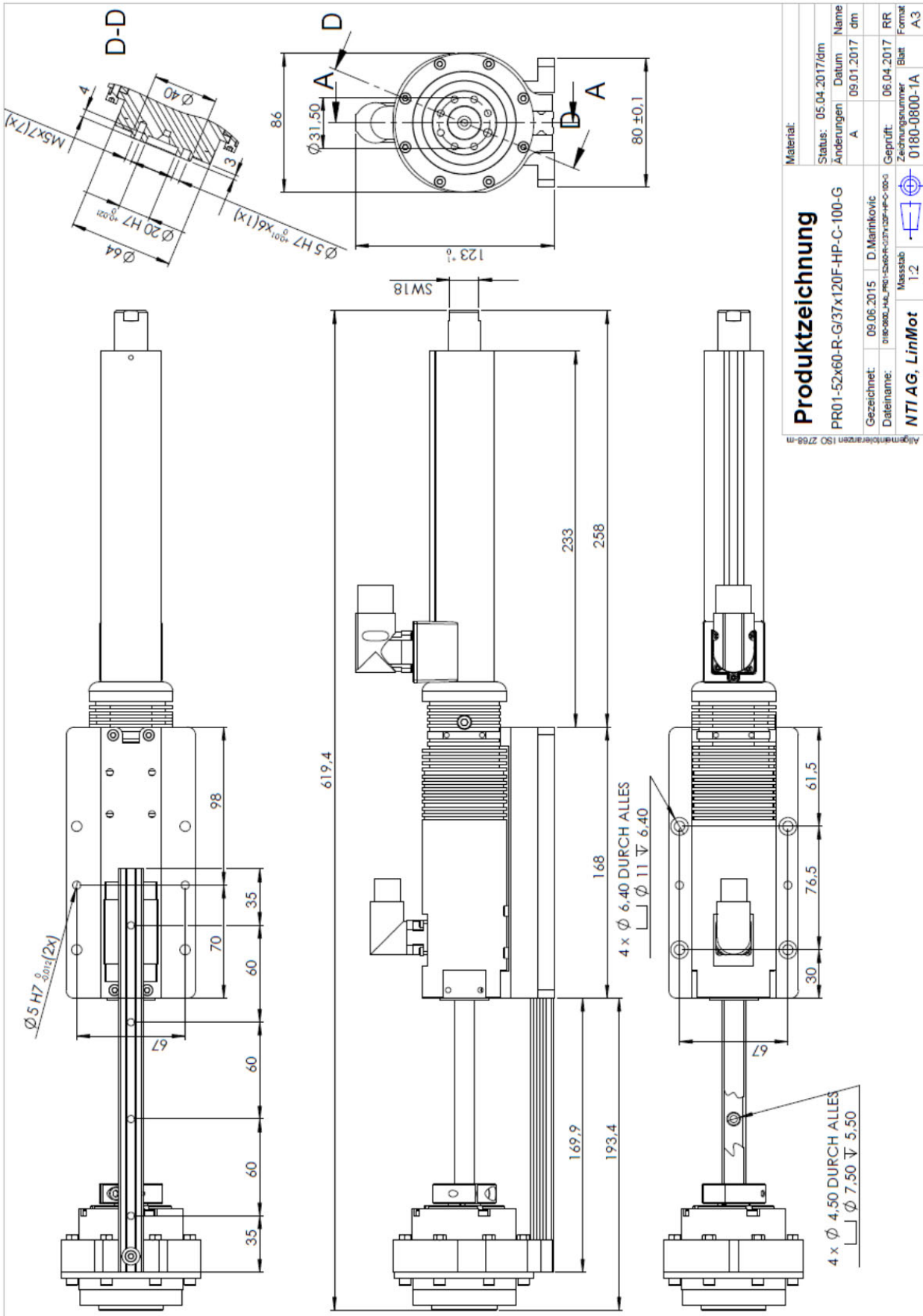

LinMot Linear Rotary Motors

Drawing PR01-84x80-C/48x240F-C-100

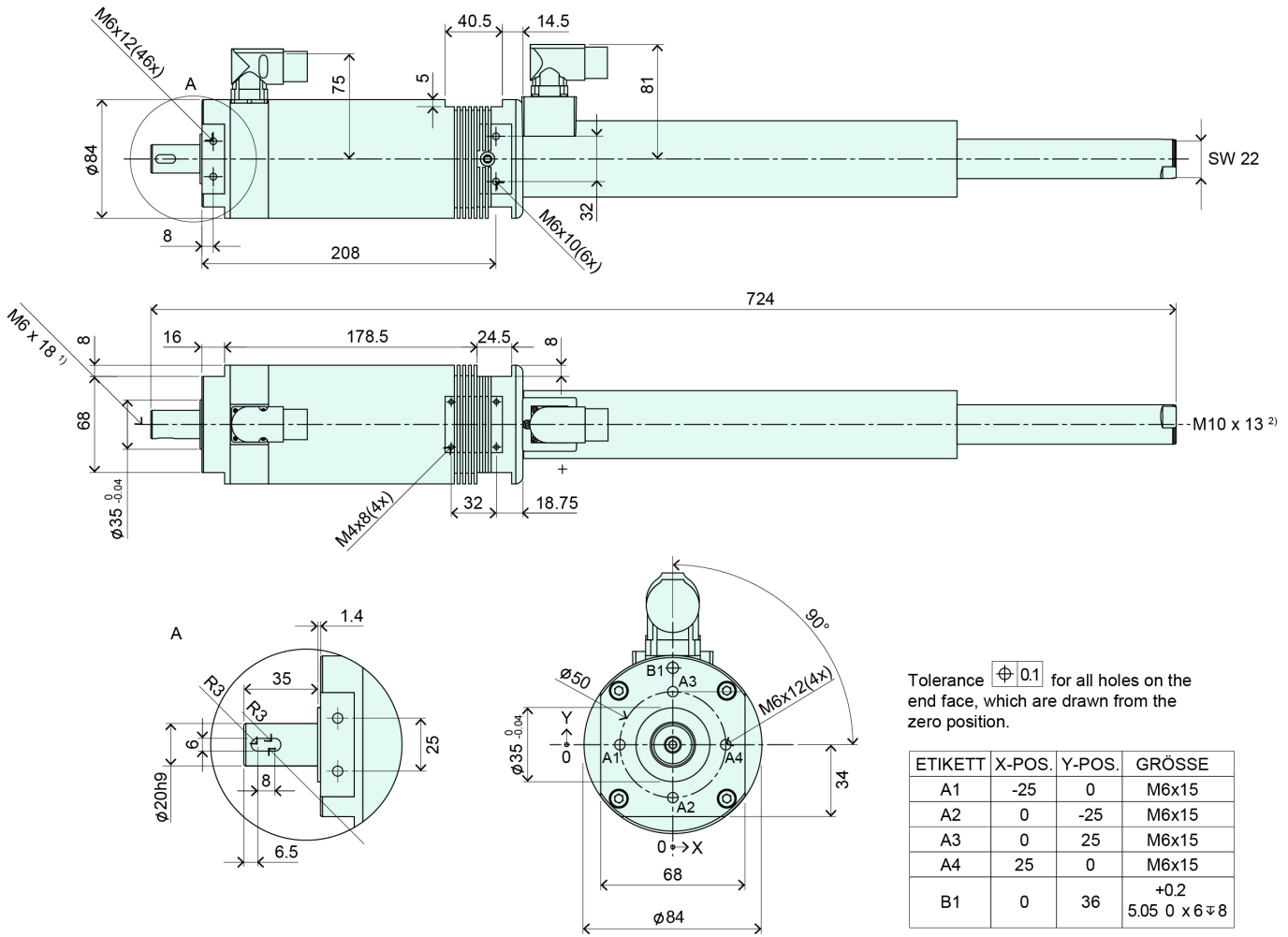

Tolerance ± 0.1 for all holes on the end face, which are drawn from the zero position.

ETIKETT	X-POS.	Y-POS.	GRÖSSE
A1	-25	0	M6x15
A2	0	-25	M6x15
A3	0	25	M6x15
A4	25	0	M6x15
B1	0	36	+0.2 5.05 0 x 6 ± 8

- 1) G1/8x7
- 2) G1/4x8

Stroke range PR01-84x80-C/48x240F-C-100

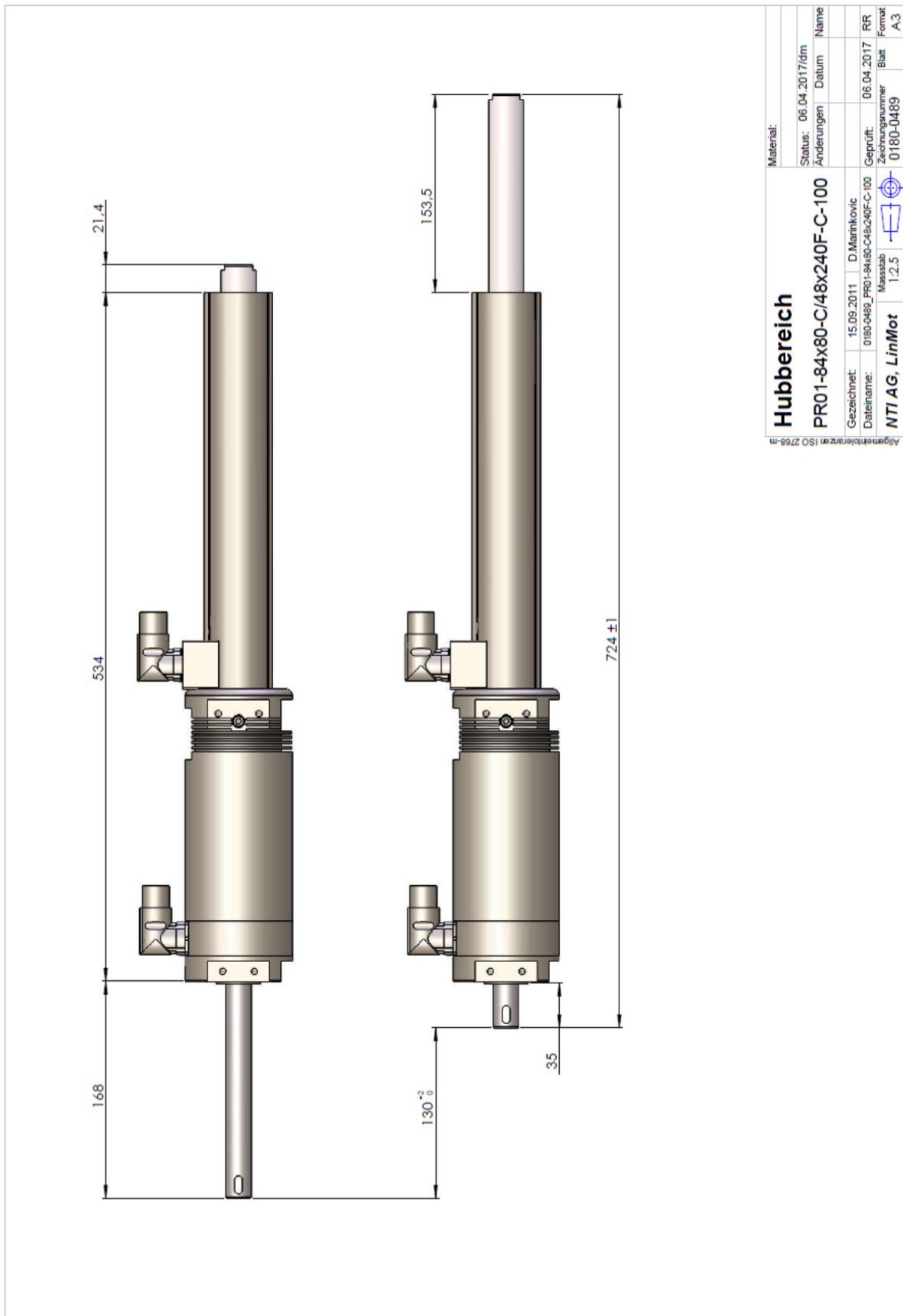

Drawing PR01-84x80-C/48x240F-C-100 MagSpring

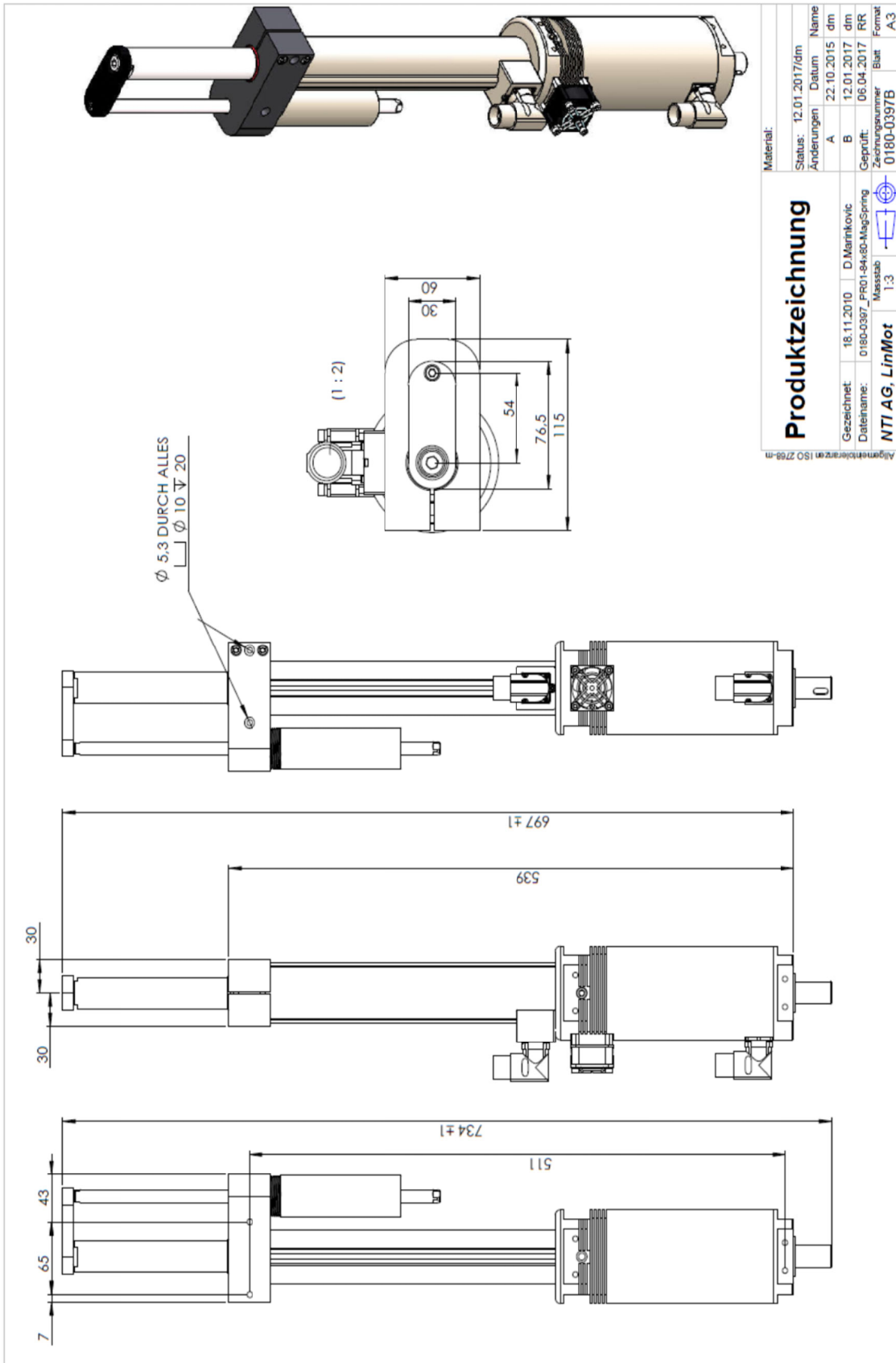

Drawing PR01-84x80-C/48x240F-C-100 with Flange and MagSpring

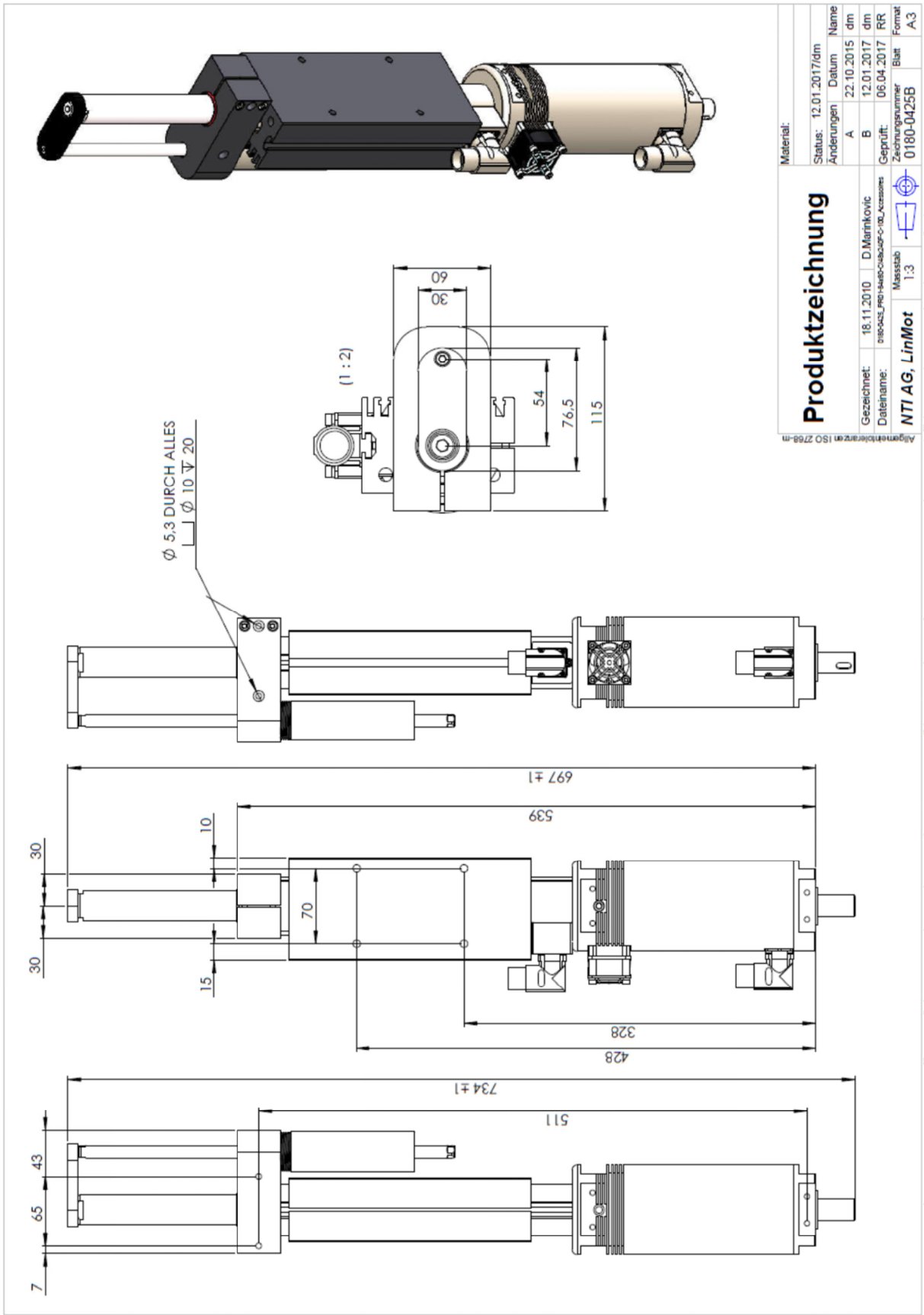

Drawing PR01-84x80-C/48x360F-C-100

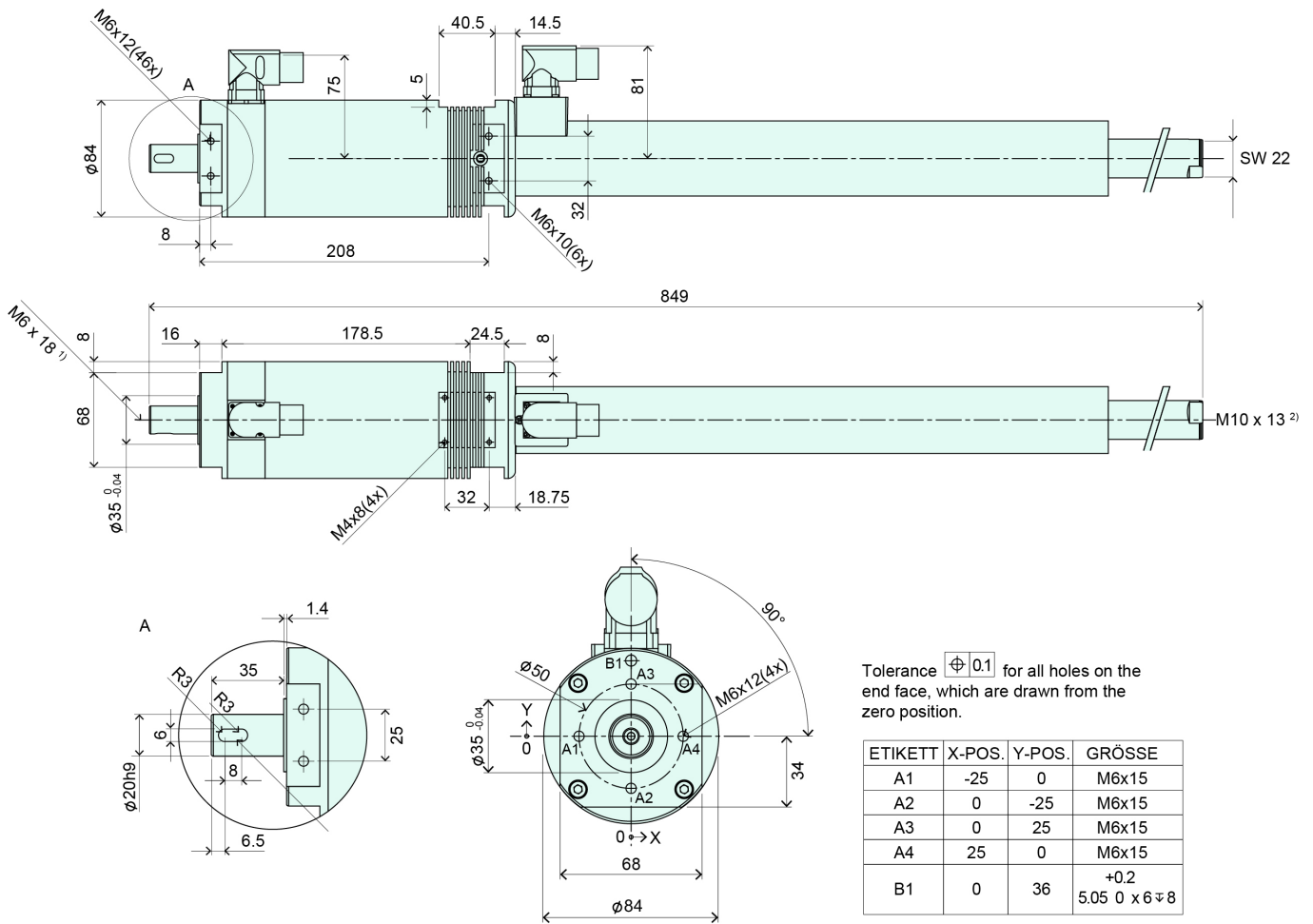

Tolerance ± 0.1 for all holes on the end face, which are drawn from the zero position.

ETIKETT	X-POS.	Y-POS.	GRÖSSE
A1	-25	0	M6x15
A2	0	-25	M6x15
A3	0	25	M6x15
A4	25	0	M6x15
B1	0	36	+0.2 5.05 0 x 6 \mp 8

- 1) G1/8x7
- 2) G1/4x8

Stroke range PR01-84x80-C/48x360F-C-100

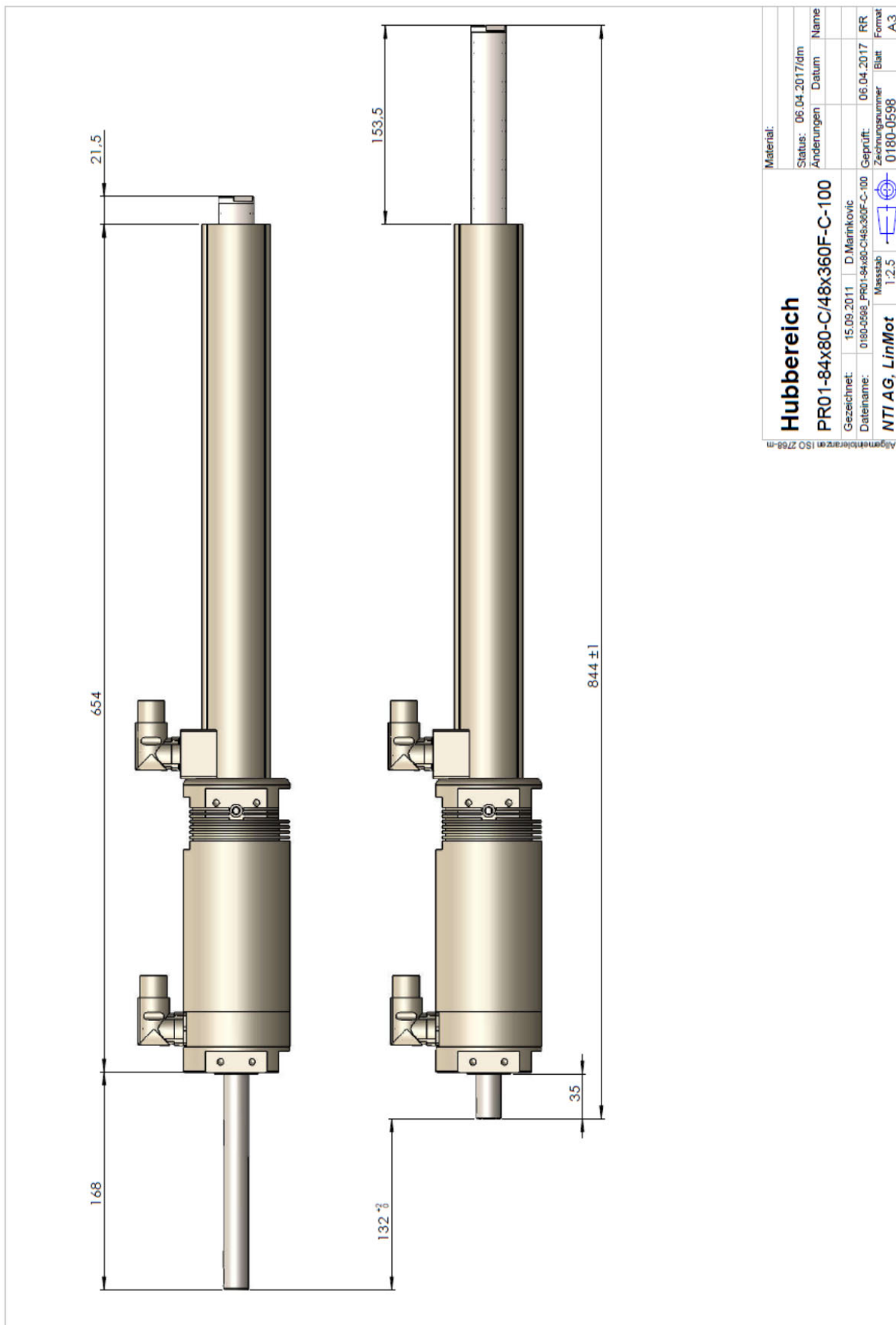

Hubbereich		Material:	
PR01-84x80-C/48x360F-C-100		Status: 06.04.2017/dm	Name
Gezeichnet: 15.09.2011 D. Marinkovic	Geprüft: 06.04.2017 RR	Änderungen	Blatt
Dateiname: 0180-0598_PR01-84x80-C/48x360F-C-100	Zeichnungsnummer: 0180-0598		Format: A3
NTI AG, LinMot	Maßstab: 1:2.5		

Das Urheberrecht an diesem Dokument, das dem Empfänger persönlich anvertraut wird, verbleibt unserer Firma. Ohne unsere schriftliche Genehmigung darf das Dokument weder kopiert noch vervielfältigt noch Dritten mitgeteilt oder zugänglich gemacht werden.

Drawing PR01-84x80-C/48x240F-C-150

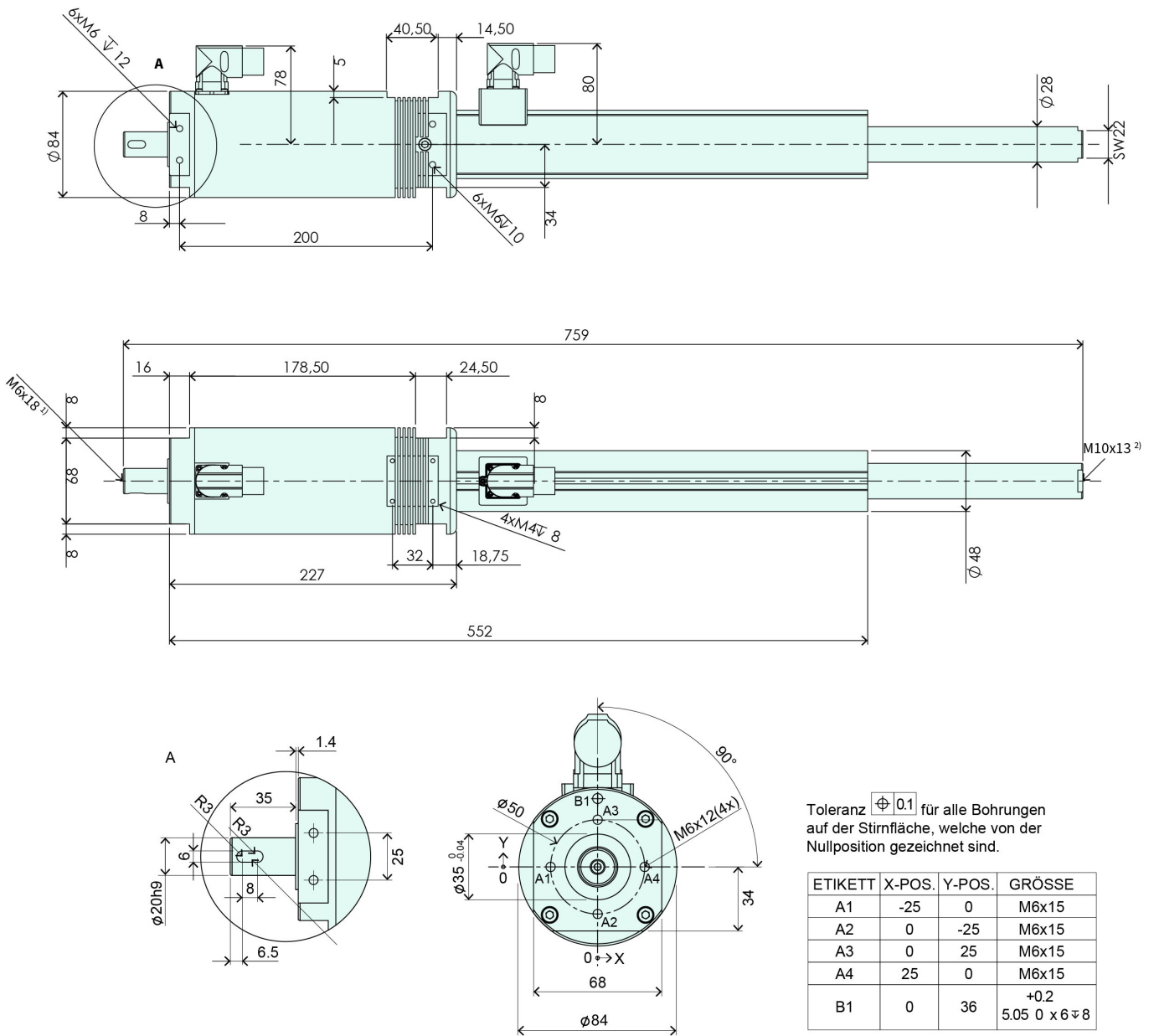

- 1) G1/8x7
- 2) G1/4x8

Stroke range PR01-84x80-C/48x240F-C-150

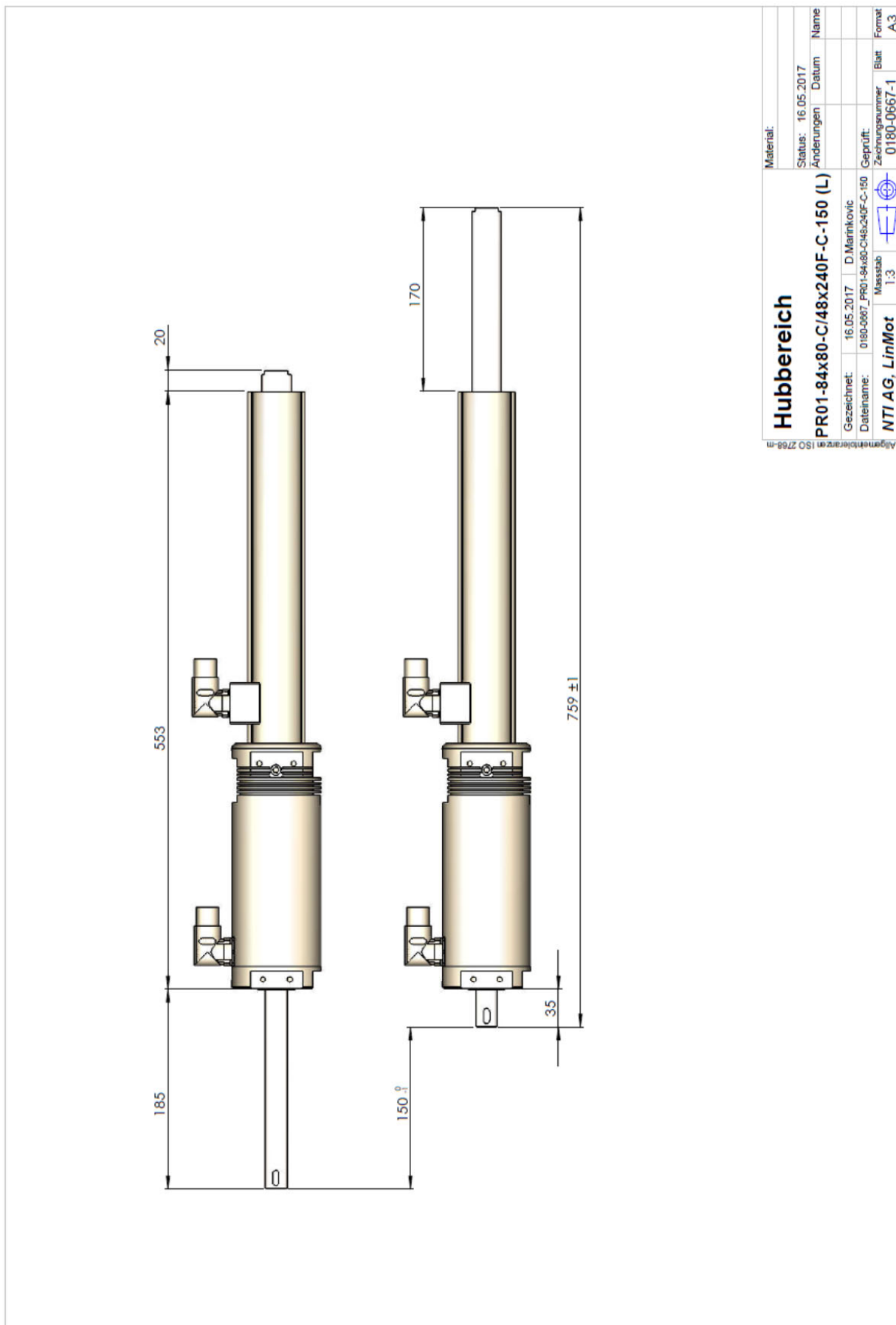

Hubbereich	
Material:	
Status:	16.05.2017
Änderungen	Datum
Name	
PR01-84x80-C/48x240F-C-150 (L)	
Gezeichnet:	16.05.2017
Datenname:	D. Marinkovic
Geprüft:	0180-0667_PR01-84x80-C/48x240F-C-150
Zeichnungsnummer	Massstab
Blatt	1:3
Format	0180-0667-1
NTI AG, LinMot	

Das Urheberrecht an diesem Dokument, das dem Empfänger persönlich anvertraut wird, verbleibt unserer Firma. Ohne unsere schriftliche Genehmigung darf das Dokument weder kopiert noch vervielfältigt noch Dritten mitgeteilt oder zugänglich gemacht werden.

Drawing PR01-84x80-C/48x360F-C-150

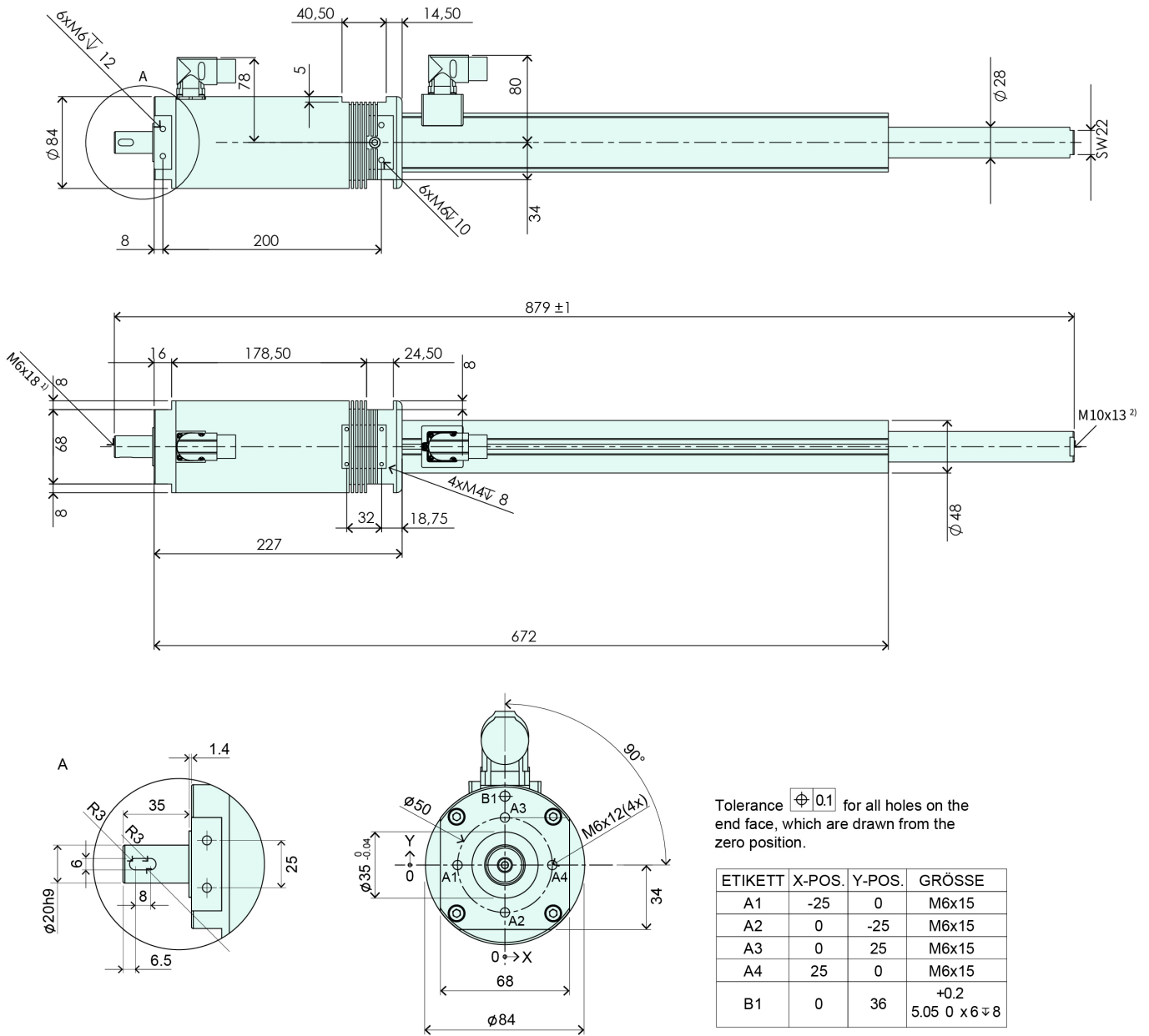

- 1) G1/8x7
- 2) G1/4x8

Stroke range PR01-84x80-C/48x360F-C-150

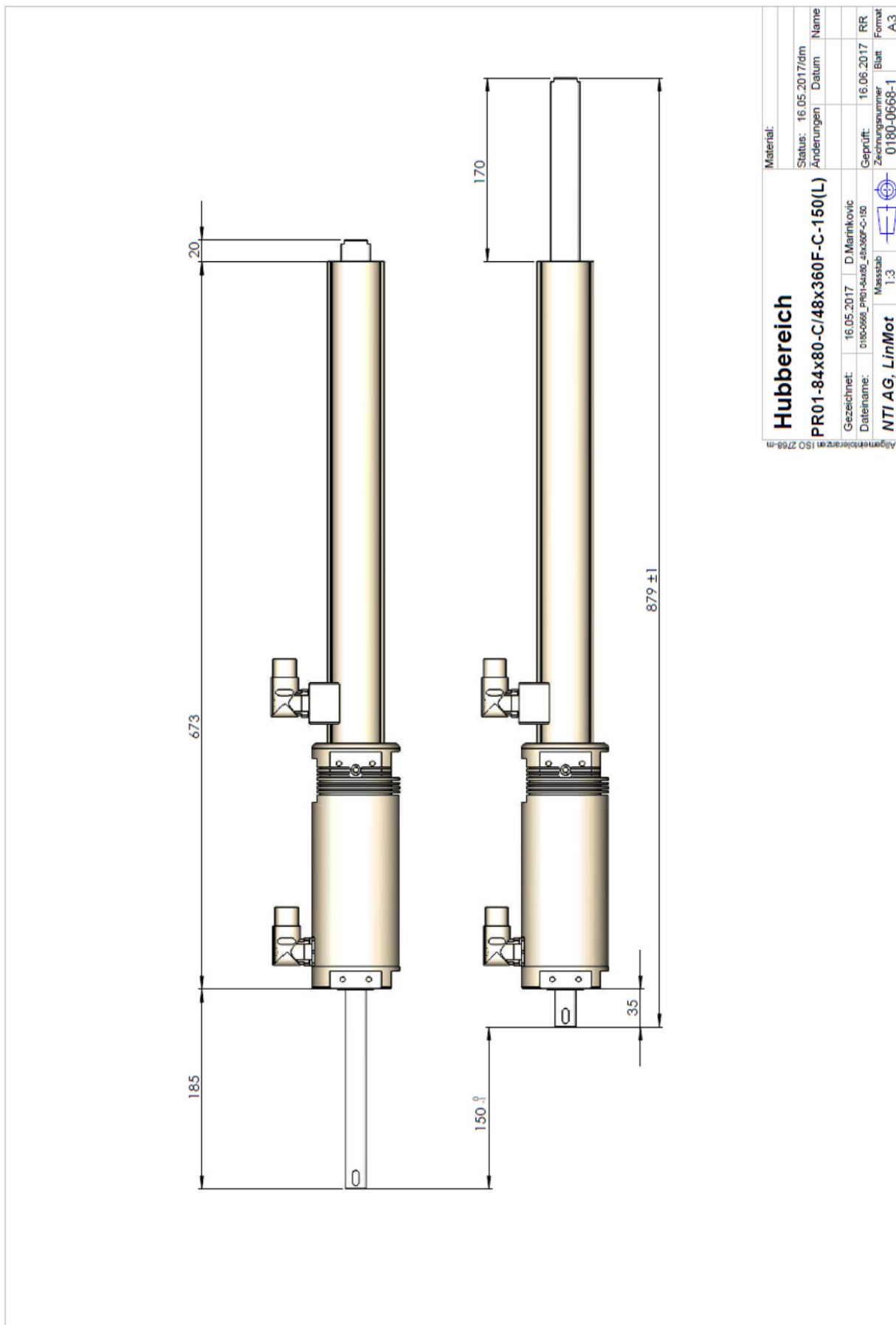

Drawing PR01-84x80-SSC-C/48x240F-C-150

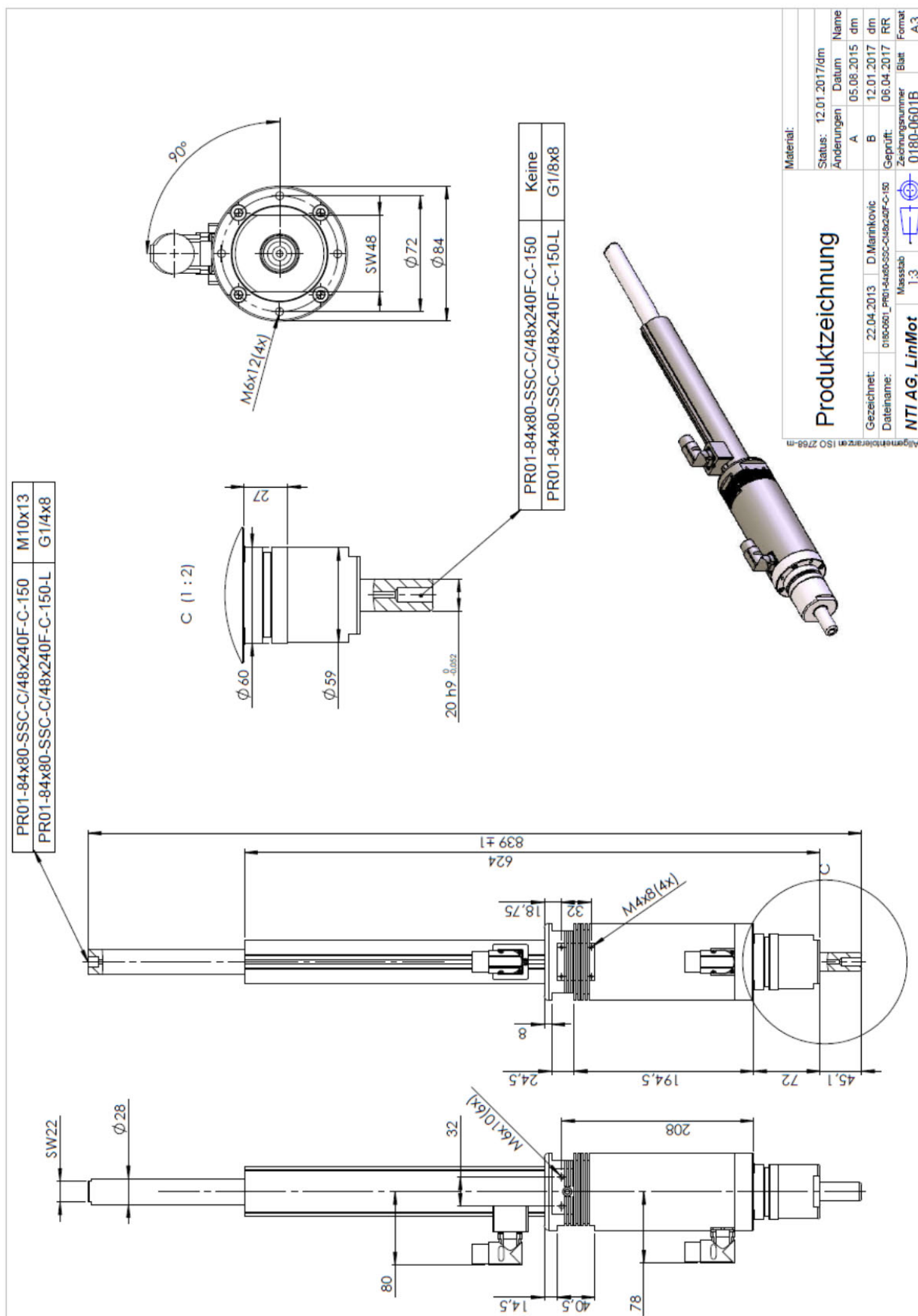

Stroke range PR01-84x80-SSC-C/48x240F-C-150

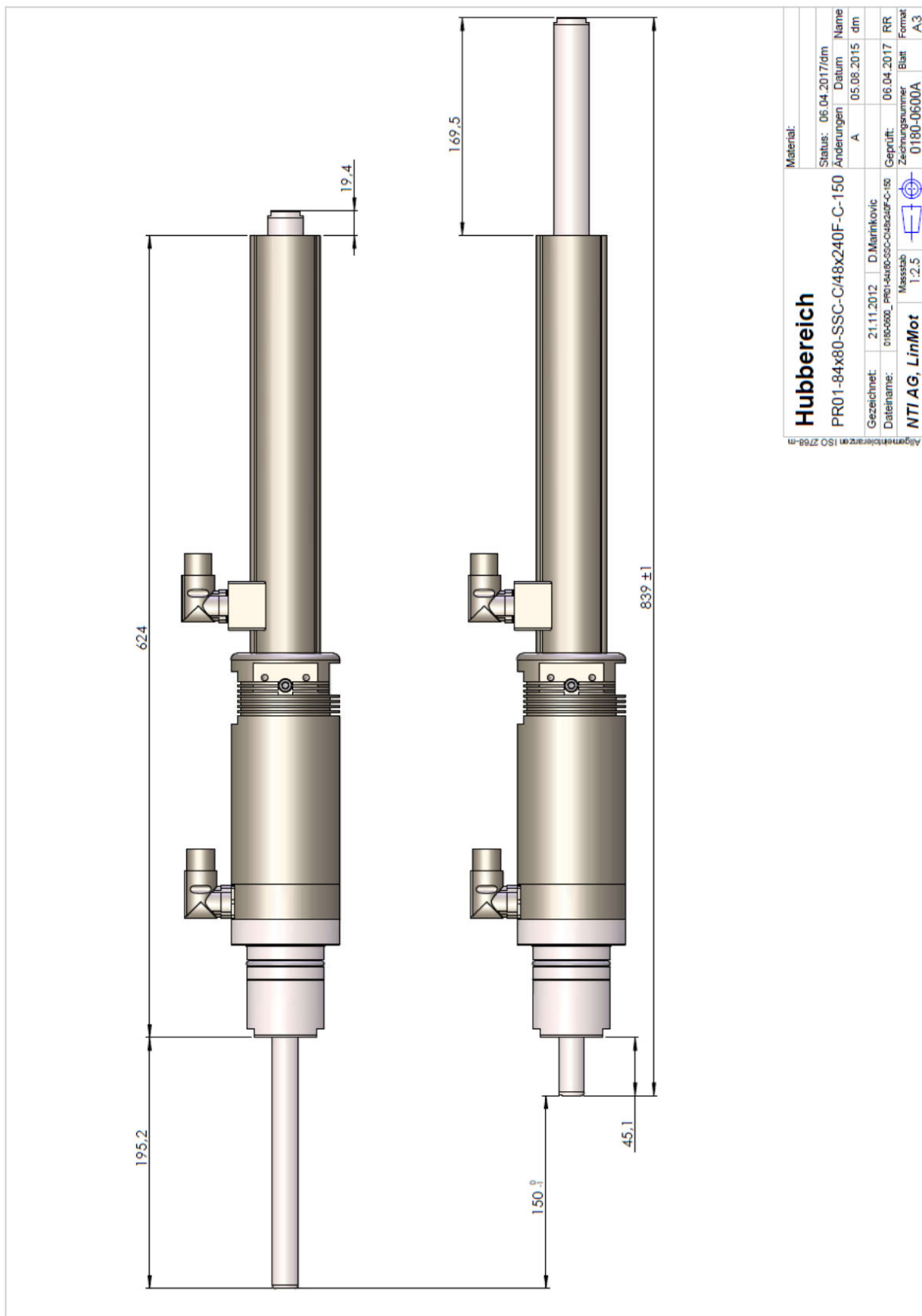

Material:		Status: 06.04.2017/dm	
Hubbereich		Änderungen: Datum Name	
PR01-84x80-SSC-C/48x240F-C-150		A 05.08.2015 dm	
Gezeichnet: 21.11.2012 D.Marinikovic	Geprüft: 06.04.2017 RR	Zerichnungsnummer Blatt Format	
Dateiname: 0185000_PR01-84x80-SSC-C/48x240F-C-150	Masstab: 1:2.5	0180-0600A A3	
NTI AG, LinMot			

Das Urheberrecht an diesem Dokument, das dem Empfänger persönlich anvertraut wird, verbleibt unserer Firma. Ohne unsere schriftliche Genehmigung darf das Dokument weder kopiert noch vervielfältigt noch Dritten personen mitgeteilt oder zugänglich gemacht werden.

Drawing PR01-84x80-SSC-C/48x360F-C-150

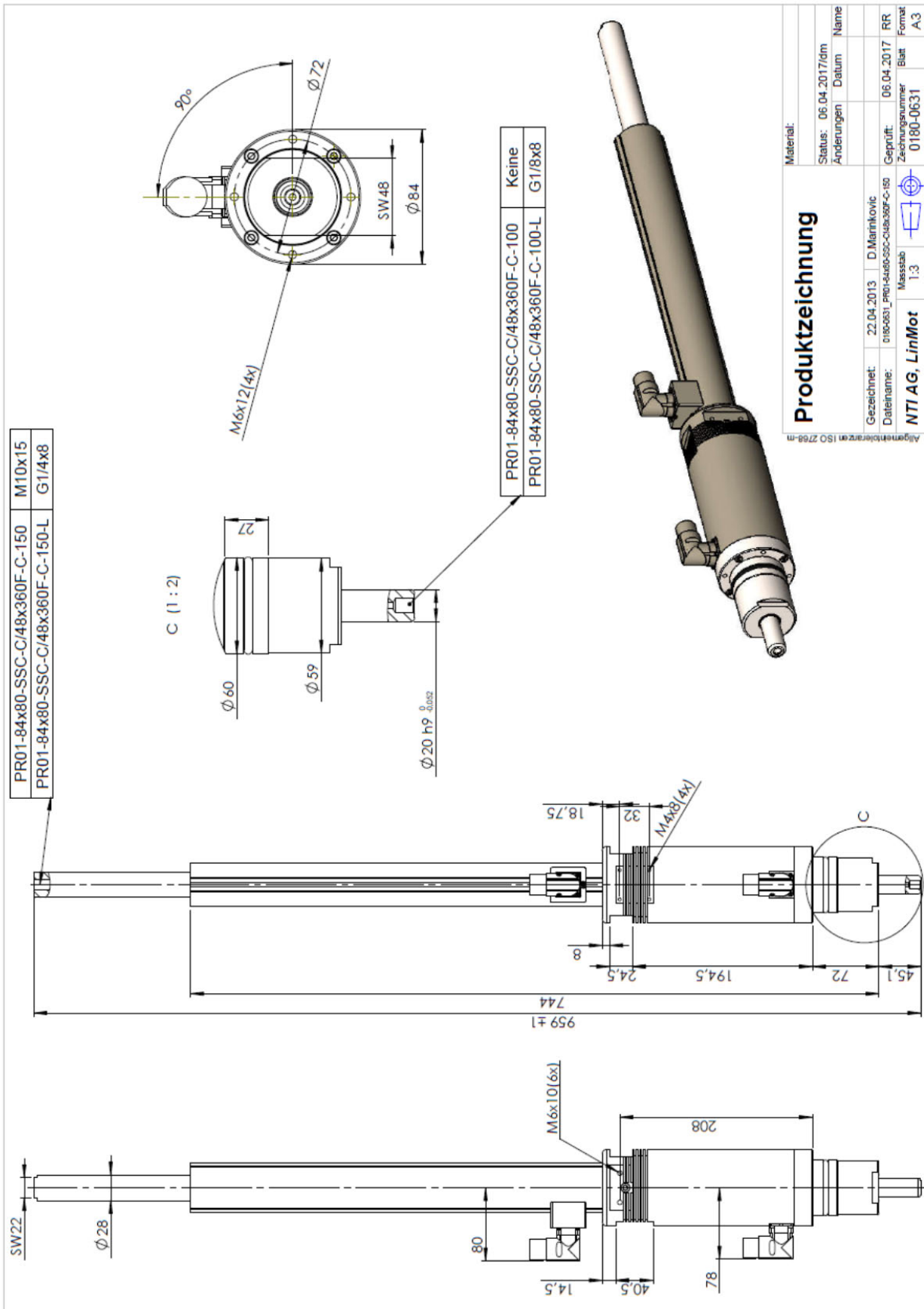

Stroke range PR01-84x80-SSC-C/48x360F-C-150

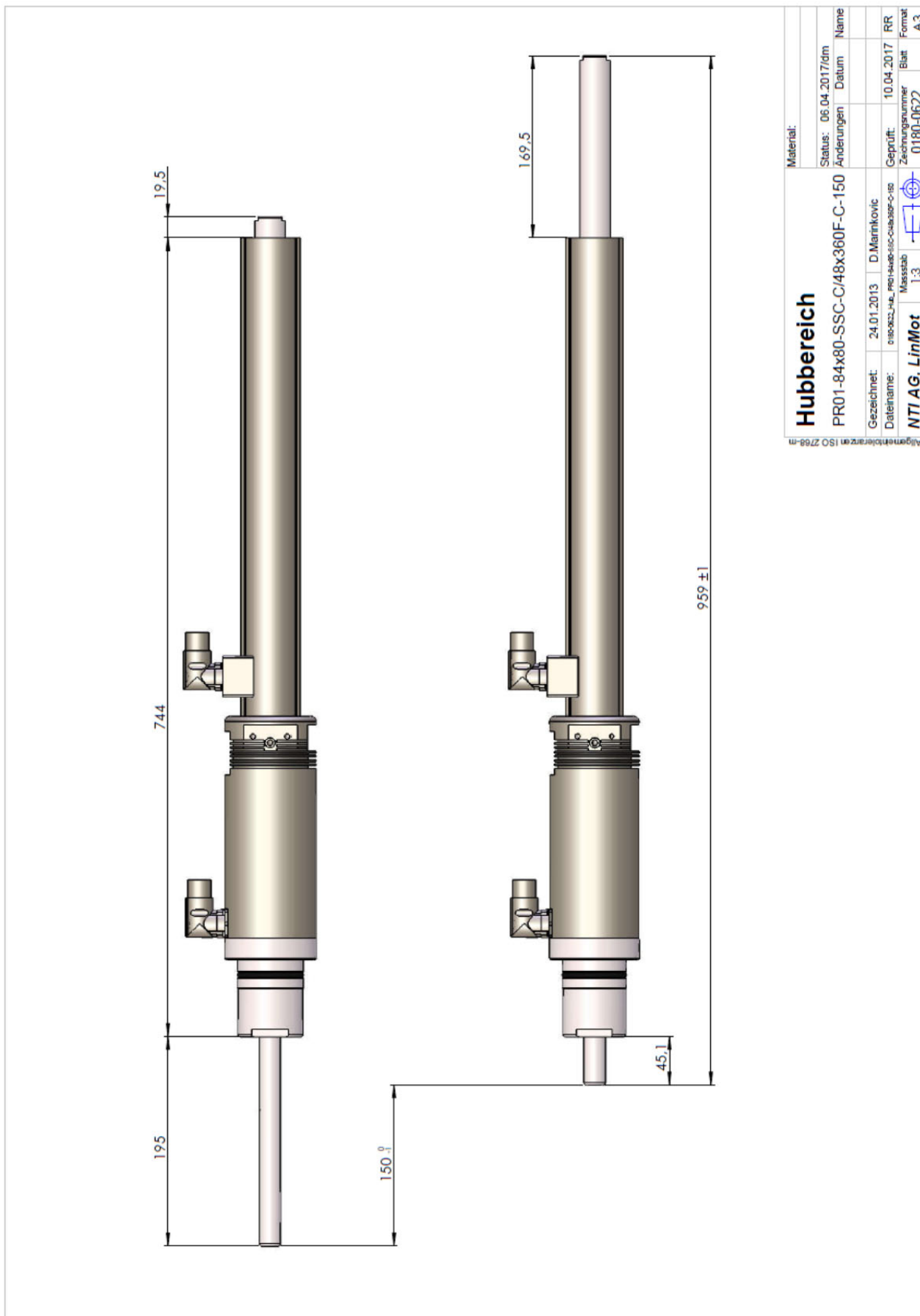

Hubbereich		Material:	
Gezeichnet:	24.01.2013	D. Marinčević	Status: 06.04.2017/dm
Datenname:	0180-062-144-PR01-84x80-SSC-C/48x360F-C-150		Änderungen
Massstab	1:3		Name
NTI AG, LinMot			
			Geprüft: 10.04.2017 RR
			Zeichnungsnummer
			Blatt
			Format
			A3

Das Urheberrecht an diesem Dokument, das dem Empfänger persönlich anvertraut wird, verbleibt unserer Firma. Ohne unsere schriftliche Genehmigung darf das Dokument weder kopiert noch vervielfältigt noch Dritten mitgeteilt oder zugänglich gemacht werden.

Drawing PR01-84x80-C / RS01-84x80-SSC-C / 48x240F-C-300

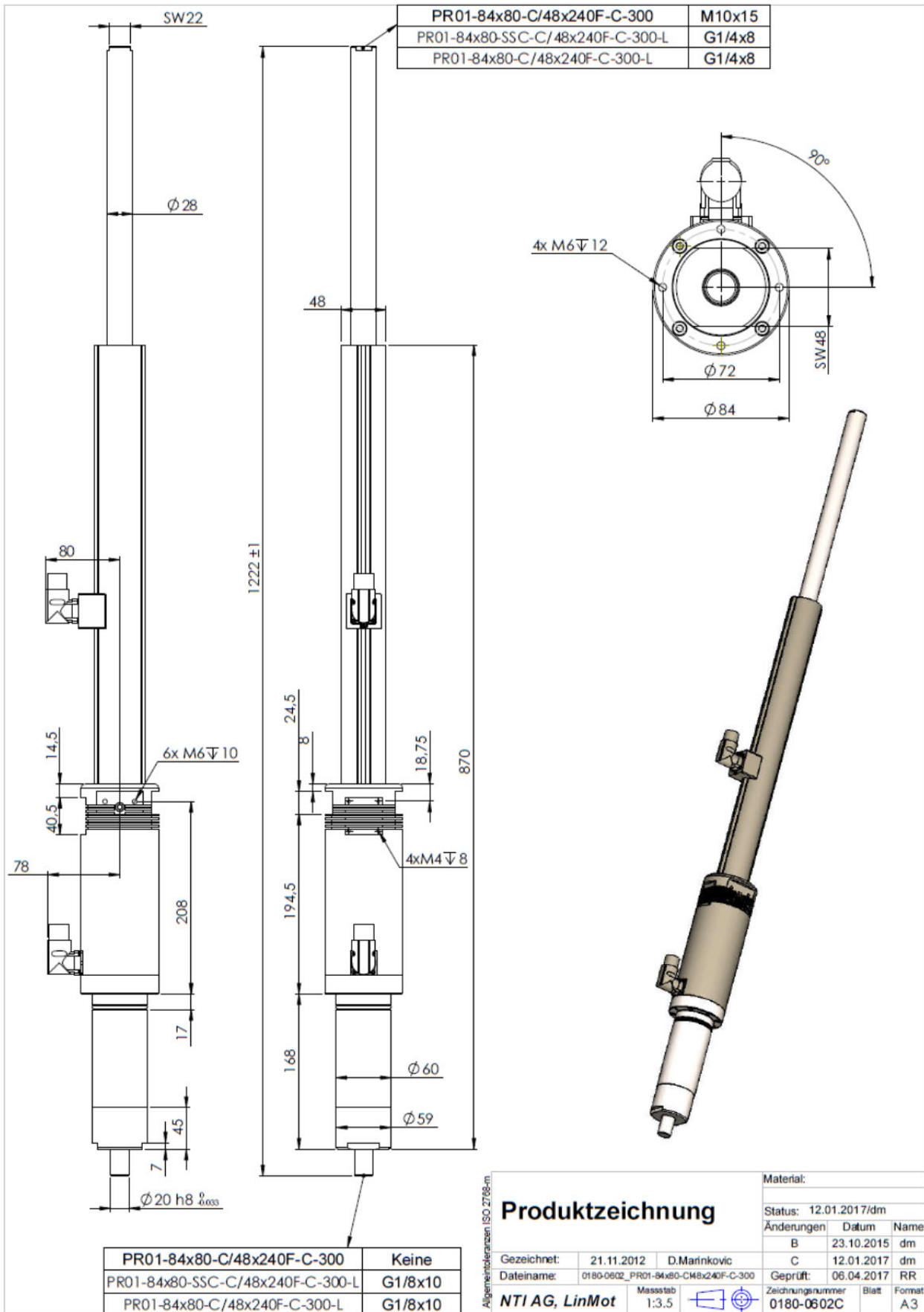

Stroke range PR01-84x80-C / RS01-84x80-SSC-C / 48x240F-C-300

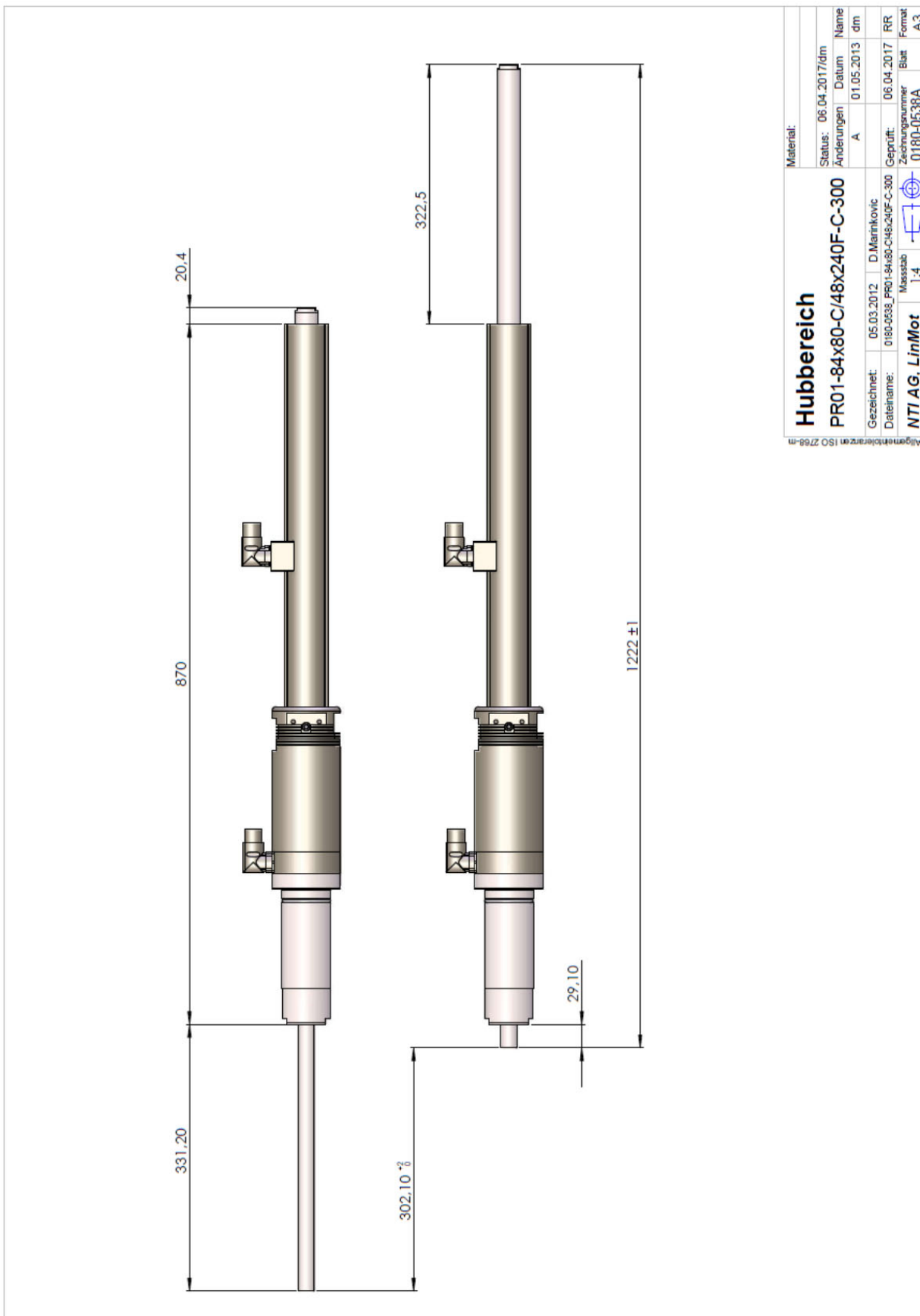

Material:	
Status:	06.04.2017/dm
Änderungen	Datum
A	01.05.2013
Name	dm
Hubbereich	
PR01-84x80-C/48x240F-C-300	
Gezeichnet:	05.03.2012 D.Marinovic
Dateiname:	0180-0538_PR01-84x80-C/48x240F-C-300
Geprüft:	06.04.2017 RR
Zeichnungsnummer	Blatt
0180-0538A	A3
NTI AG, LinMot	1:4

Das Urheberrecht an diesem Dokument, das dem Empfänger persönlich anvertraut wird, verbleibt unserer Firma. Ohne unsere schriftliche Genehmigung darf das Dokument weder kopiert noch vervielfältigt oder zugänglich gemacht werden.

Drawing PR01-84x80-C/48x240F-C-150-G..

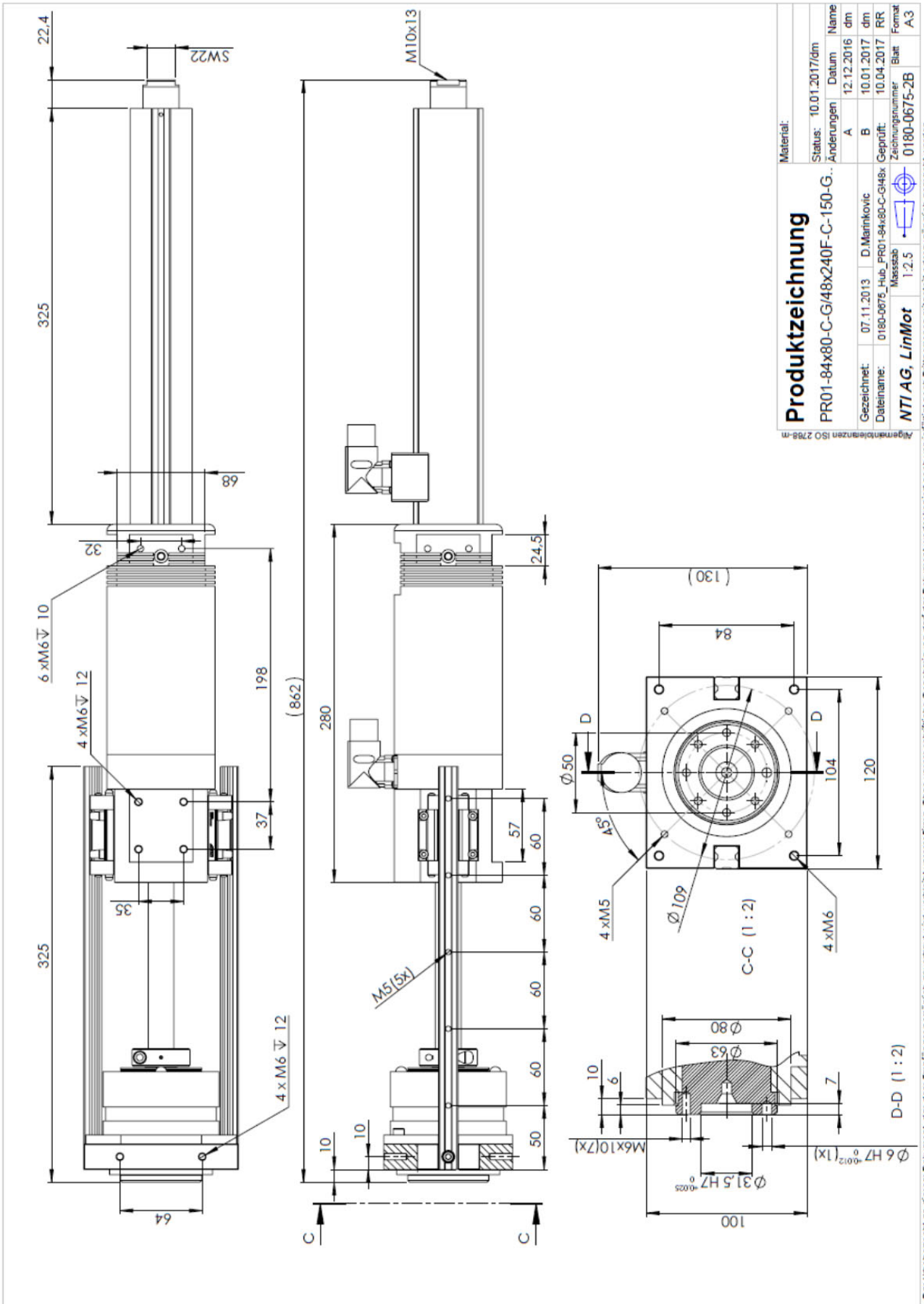

Stroke Range PR01-84x80-C/48x360F-C-150-G..

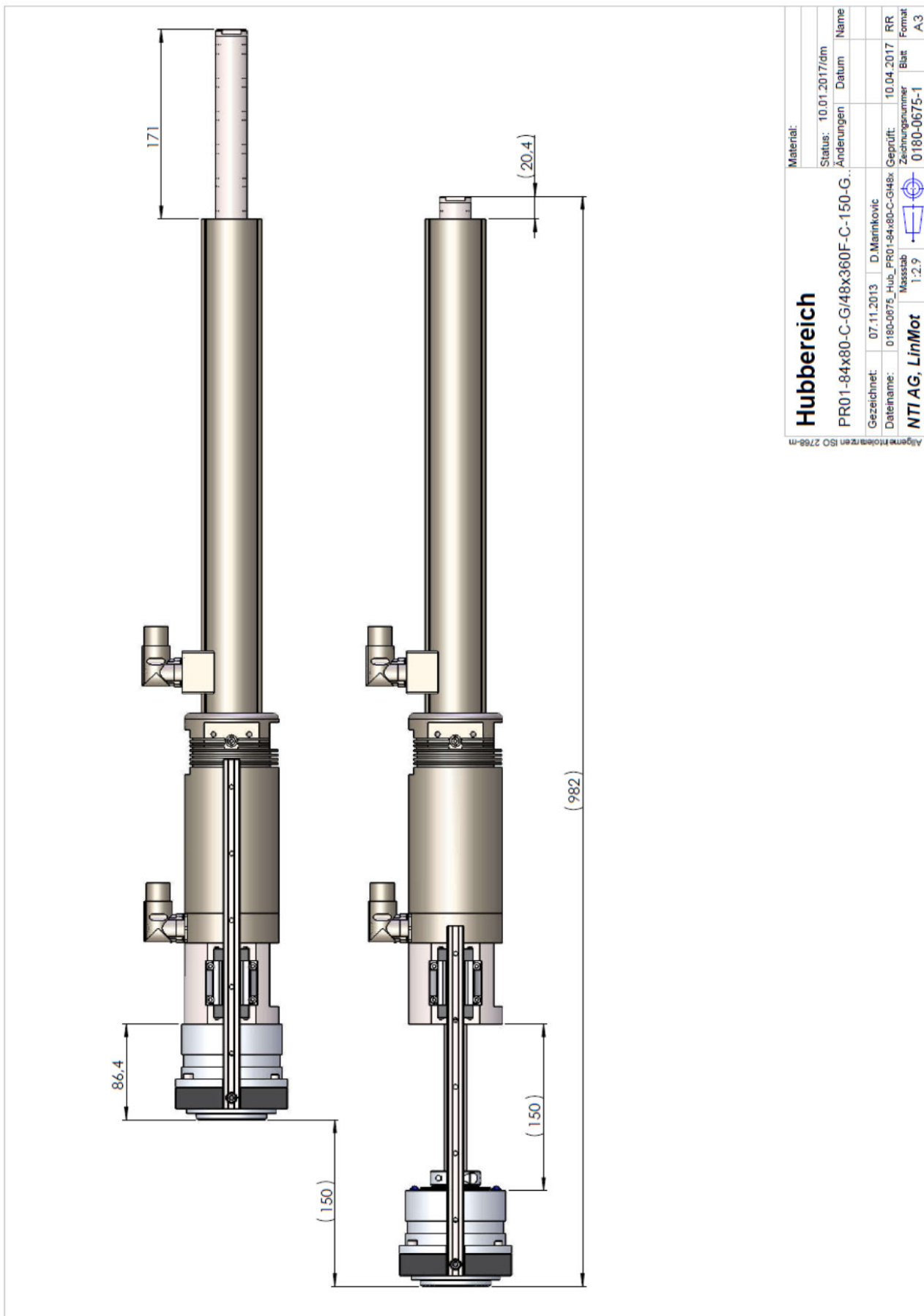

Hubbereich		Material:	
PR01-84x80-C-G/48x360F-C-150-G..		Status:	10.01.2017/dm
Gezeichnet:	07.11.2013	D. Marinkovic	Änderungen
Dateiname:	0180-0675_Hub_PR01-84x80-C-G48x	Geprüft:	10.04.2017
NTI AG, LinMot	1:2.9	Zeichnungsnummer	RR
		Blatt	0180-0675-1
		Format	A3

Das Urheberrecht an diesem Dokument, das dem Empfänger persönlich anvertraut wird, verbleibt unserer Firma. Ohne unsere schriftliche Genehmigung darf das Dokument weder kopiert noch vervielfältigt noch Dritten mitgeteilt oder zugänglich gemacht werden.

Maintenance of LinMot® Linear Rotary Motors

LinMot Stators will be shipped with an initial lubrication. Maintenance will only be required if the motors run 'dry' or there is a heavy pollution of the motors.

Under normal industrial conditions (5 day, 8h/day) one inspection every 3 months is adequate. Where conditions differ, as with severe and permanent fouling, direct sunshine, operation out in the open, increased operating temperature etc., the maintenance intervals must be shortened till empirical values for the Itemicular application are obtained.

Inspection

Inspections have to be executed according to the operating condition and the load of motors. Following points have to be checked during inspection:

- Is a film of lubricant on the slider?
- Is the wiper (if existent) without visible wear?
- Is the lubricant not adhesive?
- Can the slider and rod be moved easily?

If the motors are heavily polluted respectively if no film of lubricant is on the slider, then stators and sliders must be cleaned and lubricated again.

Cleaning and lubrication

Disassembling and cleaning

If existing, remove wiper (1) from the stator. Open fastening screws (2a, 2b and if existing 2c) between rotary motor and linear motor. Pull the stator (2) rapidly back over the slider (5) to prevent sticking to the Stator (3). Don't attempt to loosen the slider (5) from the rod (6). Attention: huge magnetic attraction of the slider! Clean slider (5), stator (3) and grooves (6) with cleaning agent LU06.

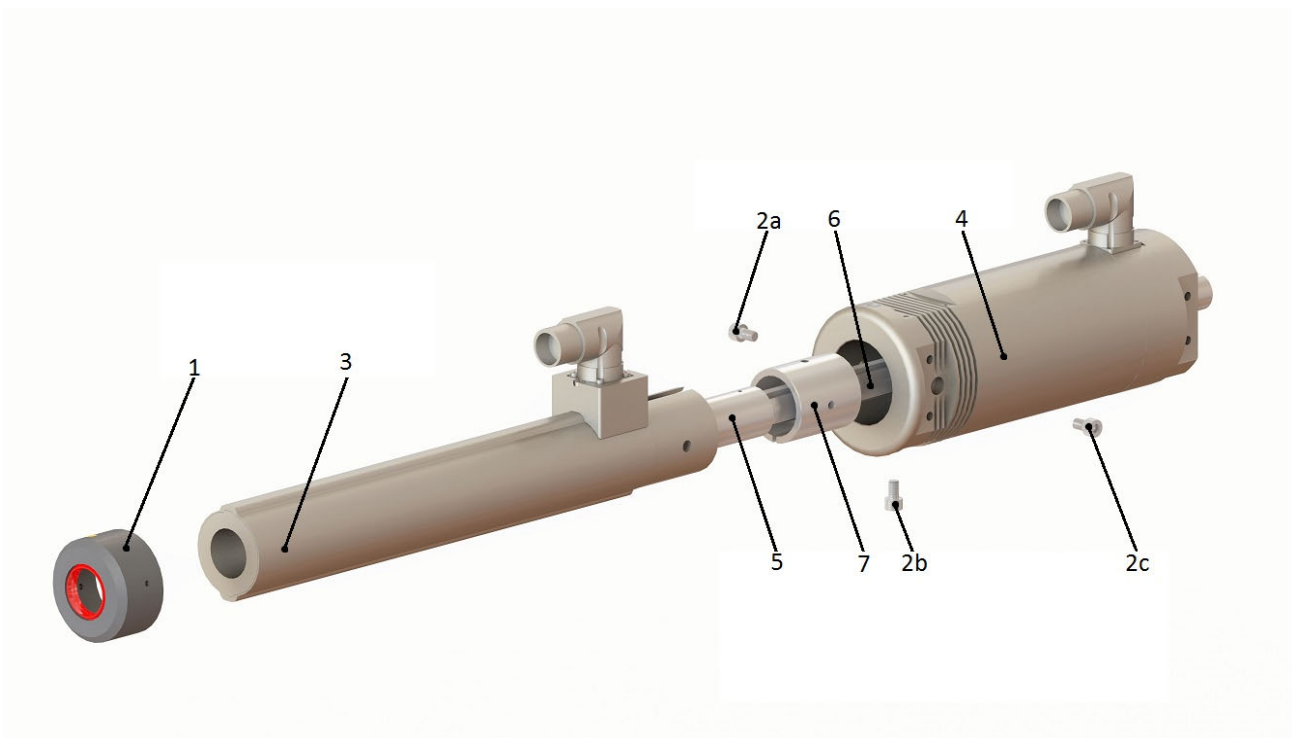

Lubrication and assembling

Lubricate the grooves (6) with 2-3 g (0.1 oz.) LU02. Lubricate the bore of the stators (3) with about 2-3 g (=0.1 oz.) lubricant LU02. There should only be a slight film of lubricant. Do not over lubricate! Lubricate the slider (5) with a soft fabric or manually. 4g (0.14 oz.) of lubricant per meter slider is enough to create a film of lubricant on the surface of the sliders. Do not over lubricate! Especially in higher operating temperatures, over lubrication can lead to a gumming of the lubricant. (In such a situation the motor must be cleaned completely.) If wipers are used then the inner side of the seals of the wipers must be lubricated as well. Do not lubricate outside of the wipers!

Assembling: move the mounting ring (7) adjusted into the stator (3). Make sure that the slider (5) is centered with a cardboard or wood wrapping because of the magnetic attraction to the outside of the stator (3). Then move the stator (3) over the slider (5). Tighten the fastening screws 2a and 2b simultaneously to make sure the slider, stator, and rotary motor are concentric. If existing then tighten screw 2c lightly in the same manner. Use bolt lock (medium).

Lubricant

The lubricant reduces the friction between the chromium-nickel steel surface of the slider and the reinforced plastic plain bearing.

LinMot[®] Lubricant LU02 Art. No. 0150-1953 (8g)

LinMot[®] Lubricant LU02 Art. No. 0150-1954 (50g)

LinMot[®] -Lubricant LU02 Art. No. 0150-1955 (1000g)

LinMot[®] LU02 Lubricant corresponds to KLÜBERSYNTH UH1 14-31 which was developed for the food processing industry.

Cleaning Agent

The following Cleaning Agent spray is recommended for LinMot Stators and Sliders:

LinMot[®] Spray LU06-250 (250ml) Art. No. 0150-2394

LinMot[®] LU06 Lubricant corresponds to KLÜBERSYNTH NH1 4—2 which was developed for the food processing industry.

Storage / transport

·Sliders are to be stored and transported only in the plastic containers (with cardboard inlay) provided for this, or already fitted in LinMot[®] motors and secured.

·Maximum storage temperature: 70 °C

Trouble Shooting

Trouble Shooting of Linear Motors

The following tables show the resistive value between the different connector pins for each stator type. If the value is not in a range of +/- 10% the stator may be damaged (temperature of the stator for all measurements: 20°C).

PS01-37x120F-HP-C-80 /-100 /-150

Phase1+ / Phase1-	Pin A / Pin B	2.6Ω	
Phase2+ / Phase2-	Pin C / Pin D	2.6 Ω	
5V / GND	Pin E / Pin F	155 Ω	
Sensor Sinus / GND	Pin G / Pin F	33 kΩ	
Sensor Cosine / GND	Pin H / Pin F	33 kΩ	
Temp. Sensor / GND	Pin L / Pin F	10kΩ	
Phase / GND	Pin A,B,C,D / Pin F	>20 MΩ	
All Pin / Shield	Pin A-L / Housing	>20 MΩ	

PS01-48x240F-C-100 (-150, -300)

Phase1+ / Phase1-	Pin A / Pin B	1.1 Ω	
Phase2+ / Phase2-	Pin C / Pin D	1.1 Ω	
5V / GND	Pin E / Pin F	155 Ω	
Sensor Sin / GND	Pin G / Pin F	33 kΩ	
Sensor Cos / GND	Pin H / Pin F	33 kΩ	
Temp. Sensor / GND	Pin L / Pin F	10 kΩ	
Phase / GND	Pin A,B,C,D / Pin F	>20 MΩ	
Alle Pins / Shield	Pin A-L / Housing	>20 MΩ	

PS01-48x360F-C-100 (-150)

Phase1+ / Phase1-	Pin A / Pin B	1.5 Ω	
Phase2+ / Phase2-	Pin C / Pin D	1.5 Ω	
5V / GND	Pin E / Pin F	155 Ω	
Sensor Sin / GND	Pin G / Pin F	33 kΩ	
Sensor Cos / GND	Pin H / Pin F	33 kΩ	
Temp. Sensor / GND	Pin L / Pin F	10 kΩ	
Phase / GND	Pin A,B,C,D / Pin F	>20 MΩ	
Alle Pins / Shield	Pin A-L / Housing	>20 MΩ	

Trouble Shooting of Rotary Motors

The following tables show the resistive value between the different connector pins for each stator type. If the value is not in a range of +/- 10% the stator may be damaged (temperature of the stator for all measurements: 20°C).

RS01-52x40-R

Phase A / Phase B	Pin 1 / Pin 2	7.1Ω	
Phase A / Phase C	Pin 1 / Pin 3	7.1 Ω	
5V / GND	Pin A / Pin B	155 Ω	
Sensor Sinus / GND	Pin C / Pin B	33 kΩ	
Sensor Cosine / GND	Pin D / Pin B	33 kΩ	
Temp. Sensor / GND	Pin E / Pin B	10kΩ	
Phase / GND	Pin 1,2,3 / Pin B	>20 MΩ	
All Pin / Shield	Pin 1-E / Housing	>20 MΩ	

RS01-52x60 /-R /R-G /R-150

Phase A / Phase B	Pin 1 / Pin 2	3Ω	
Phase A / Phase C	Pin 1 / Pin 3	3 Ω	
5V / GND	Pin A / Pin B	155 Ω	
Sensor Sinus / GND	Pin C / Pin B	33 kΩ	
Sensor Cosine / GND	Pin D / Pin B	33 kΩ	
Temp. Sensor / GND	Pin E / Pin B	10kΩ	
Phase / GND	Pin 1,2,3,4 / Pin B	>20 MΩ	
All Pin / Shield	Pin 1-E / Housing	>20 MΩ	

RS01-52x60-R (Delivery until June 2011)

Phase A / Phase B	Pin 1 / Pin 2	11.9Ω	
Phase A / Phase C	Pin 1 / Pin 3	11.9 Ω	
5V / GND	Pin A / Pin B	155 Ω	
Sensor Sinus / GND	Pin C / Pin B	33 kΩ	
Sensor Cosine / GND	Pin D / Pin B	33 kΩ	
Temp. Sensor / GND	Pin E / Pin B	10kΩ	
Phase / GND	Pin 1,2,3 / Pin B	>20 MΩ	
All Pin / Shield	Pin 1-E / Housing	>20 MΩ	

RS01-84x80 /-C /-SSC-C /-SSC-C-300 /-C-300 /-C-G

Phase A / Phase B	Pin A / Pin B	1.1Ω	
Phase A / Phase C	Pin A / Pin C	1.1 Ω	
5V / GND	Pin E / Pin F	155 Ω	
Sensor Sinus / GND	Pin G / Pin F	33 kΩ	
Sensor Cosine / GND	Pin H / Pin F	33 kΩ	
Temp. Sensor / GND	Pin L / Pin F	10kΩ	
Phase / GND	Pin A,B,C,D / Pin F	>20 MΩ	
All Pin / Shield	Pin A-L / Housing	>20 MΩ	

Caution: Handling Instructions for Sliders

LinMot Slider

LinMot® Linear Motor sliders must be handled with care especially if not assembled within the stator! Damaging or warping of the slider can result in shortened life and/or failure of the motor. The slider is essentially a high-precision machine component consisting of neodymium magnets and plastic materials assembled in a thin steel tube. Do not use sliders who are already damaged on the surface (scratches, deformation, etc.). This can provide a further damage of the stator! Keep slider away from unshielded flame or heat. Temperature of more than 120°C will cause demagnetization.



Magnetism

LinMot® sliders contain neodymium magnets which may disturb or damage magnetic data carriers and delicate electronic equipment merely by coming close to them. Examples for such equipment are: television and computer monitors, credit cards and EC-cards, computers, floppy discs and other data storage medium, video tapes, mechanical watches, hearing devices and loudspeaker. Heart pacemakers can be disturbed by strong magnets. Keep a minimum distance of 1m.



Crushes

When handling sliders be aware that, due the strong magnetic attraction, serious injury from fingers being pinched between the slider and nearby steel items is a very real possibility if caution is not exercised.



No modification of sliders provided by customers is allowed!

Do not modify the slider in any way. Any modification could destroy the included magnets and magnet dust can be build. Magnet dust is easily inflammable! NdFeB-Magnets are not made of steel. These magnets are sintered and due to that highly breakable.



Declaration of Conformity and CE-Marking

We **NTI AG**
LinMot®
Bodenaeckerstrasse 2
CH-8957, Spreitenbach

declare our sole responsibility, that the product

Item	Item-No.	Item	Item-No.
PR01-52x40-R/37x120F-HP-C-80	0150-1573	PR01-84x80-C/48x360F-C-100-L	0150-1200
PR01-52x40-R/37x120F-HP-C-80-L	0150-2703	PR01-84x80-C/48x360F-C-150	0150-1168
PR01-52x60-R/37x120F-HP-C-100	0150-1197	PR01-84x80-C/48x360F-C-150-L	0150-1166
PR01-52x60-R/37x120F-HP-C-100-L	0150-2704	PR01-84x80-SSC-C/48x240F-C-150	0150-1581
PR01-52x60-R/37x120F-HP-C-150	0150-2705	PR01-84x80-SSC-C/48x240F-C-150-L	0150-1582
PR01-52x60-R/37x120F-HP-C-150-L	0150-2706	PR01-84x80-SSC-C/48x240F-C-300-L	0150-2555
PR01-52x60-R-G/37x120F-HP-C-100-G05	0150-2648	PR01-84x80-SSC-C/48x360F-C-150	0150-1579
PR01-52x60-R-G/37x120F-HP-C-100-G10	0150-2647	PR01-84x80-SSC-C/48x360F-C-150-L	0150-1583
PR01-84x80-C/48x240F-C-100	0150-1194	PR01-84x80-C-G/48x240F-C-150-G05	0150-2531
PR01-84x80-C/48x240F-C-100-L	0150-1196	PR01-84x80-C-G/48x240F-C-150-G07	0150-2532
PR01-84x80-C/48x240F-C-150	0150-1187	PR01-84x80-C-G/48x240F-C-150-G10	0150-2533
PR01-84x80-C/48x240F-C-150-L	0150-1188	PR01-84x80-C-G/48x360F-C-150-G05	0150-2535
PR01-84x80-C/48x240F-C-300	0150-1580	PR01-84x80-C-G/48x360F-C-150-G07	0150-2536
PR01-84x80-C/48x240F-C-300-L	0150-2554	PR01-84x80-C-G/48x360F-C-150-G10	0150-2537
PR01-84x80-C/48x360F-C-100	0150-1199		

Is conform to the provisions of directives

2014/30/EU

based on the following standards

EN61000-6-2: 2005

EN61000-6-4: 2007

Year of CE marking:

2014

Spreitenbach, 10.3. 2017



Dr.-Ing. Ronald Rohner
CEO NTI AG

CB Test Certificate

 	Ref. Certif. No. CH-8521
---	---------------------------------

IEC SYSTEM FOR MUTUAL RECOGNITION OF TEST CERTIFICATES FOR ELECTRICAL EQUIPMENT (IECEE)
CB SCHEME

CB TEST CERTIFICATE	
Product	Linear motor
Name and address of the applicant	NTI AG Bodenackerstrasse 2 SWITZERLAND 8957 Spreitenbach
Name and address of the manufacturer	NTI AG Bodenackerstrasse 2 SWITZERLAND 8957 Spreitenbach
Name and address of the factory	NTI AG Bodenackerstrasse 2 SWITZERLAND 8957 Spreitenbach
<i>Note: When more than one factory, please report on page 2</i>	<input type="checkbox"/> Additional Information on page 2
Ratings and principal characteristics	supplied via servo drive, see TR 17-EL-0006.E02 for details
Trade mark (if any)	LinMot
Customers's Testing Facility (CTF) Stage used	---
Model / Type Ref.	PR series PS series P04 series P05 series
Additional information (if necessary may also be reported on page 2)	---
A sample of product was tested and found to be in conformity with IEC	<input type="checkbox"/> Additional Information on page 2 IEC 61000-6-2:2016 IEC 61000-6-4:2006, IEC 61000-6-4:2006/AMD1:2010 IEC 61000-6-7:2014
National differences	EU Group Differences; EU Special National Conditions; EU A-Deviations
As shown in the Test Report Ref. No. which forms part of this Certificate	17-EL-0006.E01 + .E02 + .Z01



This CB Test Certificate is issued by the National Certification Body

Electrosuisse Luppenstrasse 1 8320 Fehraltorf SWITZERLAND		 electro suisse
Signed by: Martin Plüss Date: 2017-03-13		page 1 of 1

Contact address:

NTI AG

LinMot
Bodenaeckerstrasse 2
CH-8957 Spreitenbach

Tel. +41 (0)56 419 9191
Fax. +41 (0)56 419 9192
email: office@LinMot.com
Web: www.LinMot.com

LinMot Inc.

N1922 State Road 120, Unit 1
Lake Geneva
WI 53147
USA

Phone: 262-743-2555
email: usasales@LinMot.com
Web: www.LinMot.com

Liability

NTI AG / LinMot (LinMot) is not responsible for any damages caused by improper use, application, or handling of LinMot manufactured or supplied materials and is not responsible for any consequential damages of any sort relating to the use of LinMot products.

LinMot's warranty is limited to repair or replacement as stated in our standard warranty policy as described in our "terms and conditions" previously supplied to the purchaser of our equipment (please request copy of same if not otherwise available). Product warranties are void if LinMot products are used with stators, sliders, or controllers not manufactured by LinMot unless such use was specifically approved by LinMot.

A copy of this notice must be attached to each motor and/or machine that the purchaser provides to others.

LinMot®, LinRot® and MagSpring® are registered trademarks of NTI AG

Specification of products are subject to change without notification

Edition: 2011
2012
2013
2014
2015
2016
2017
2018