

The copyright in this document, which is personally entrusted to the recipient, remains with our company. Without our written permission, the document may not be copied, reproduced, communicated or made accessible to third parties without our written permission.

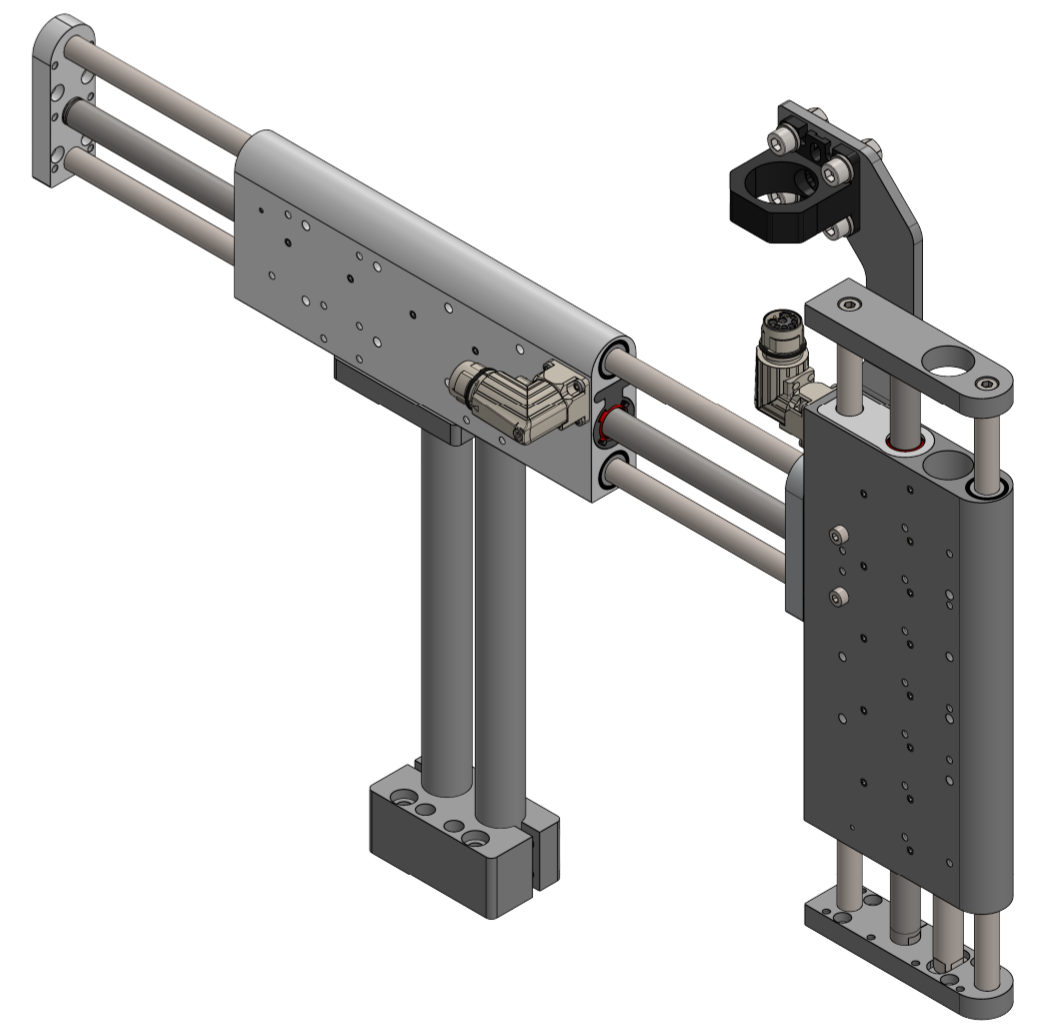
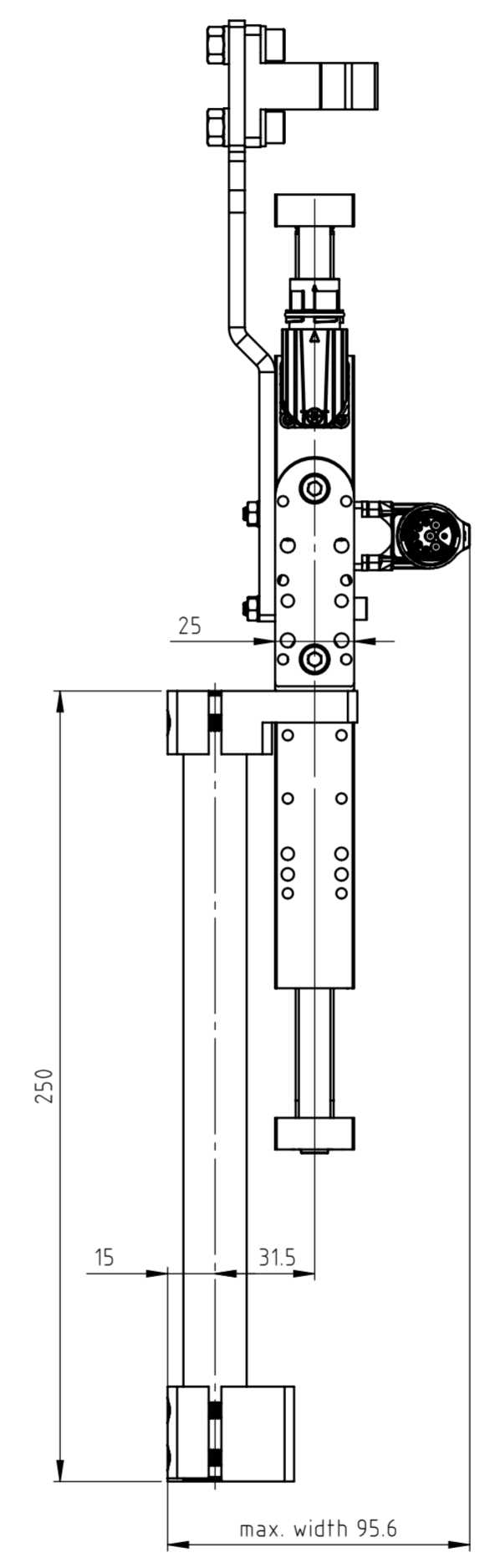
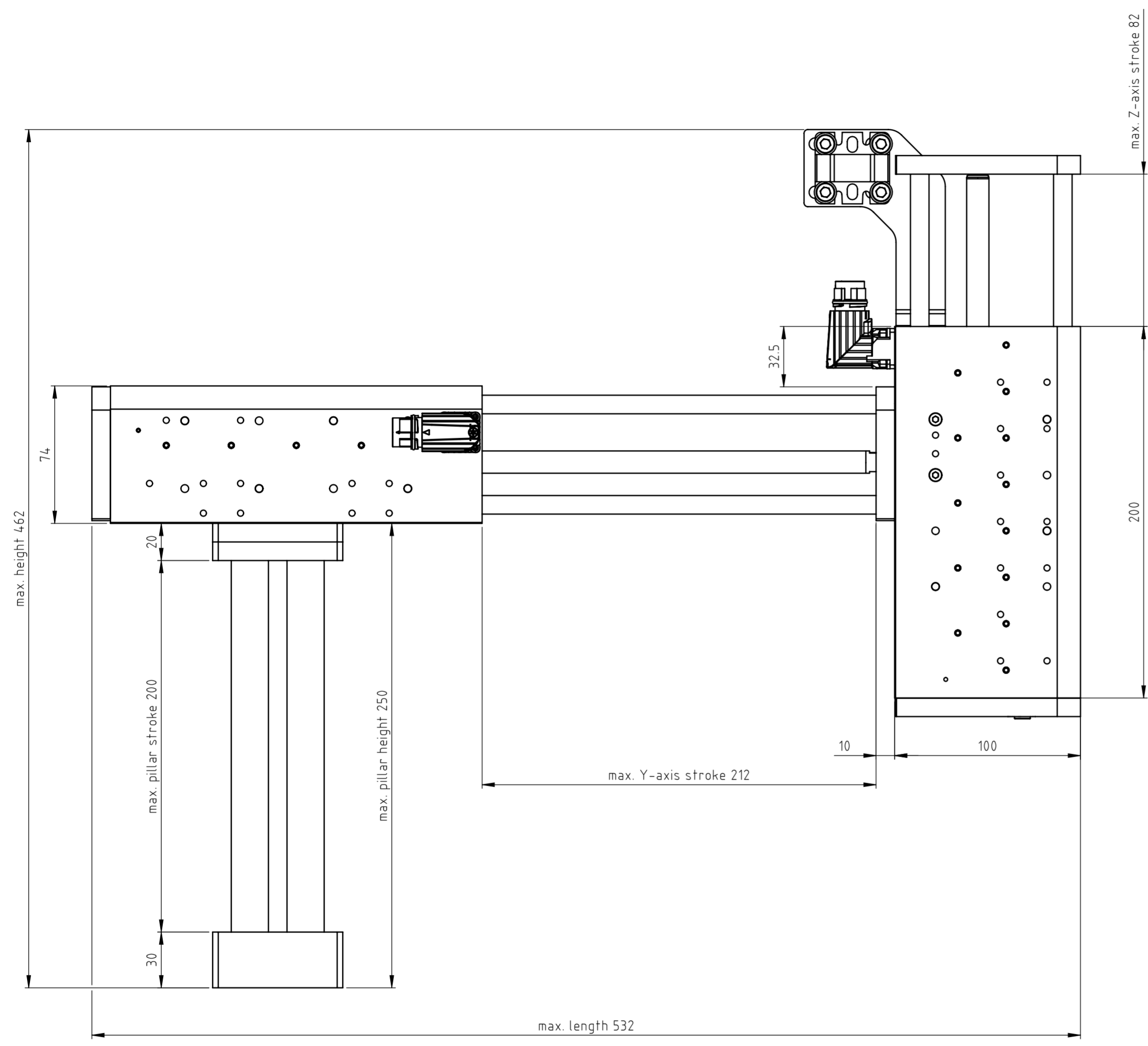

A	Document created	14.11.2024	JB	FH
Rev.	Change	Date	Author	Appr.

General tolerance DIN ISO 2768 - mK	Created by J.-E. Beekhuis	Status 13.12.2024 / jb	Material
<b>LinMot®</b>	File name 0380-0003_PP_DM01-210-MT08_DM03-80-MT08-MS11_PS01_TC01	<input type="checkbox"/> Safety Rel. <input type="checkbox"/> UL-Rel.	Weight (g)
NTI AG LinMot & MagSpring Bodenaeckerstrasse 2 CH-8957 Spreitenbach	Title, additional title PP_DM01-210-MT08_ DM03-80-MT08-MS11_PS01_TC01	Document type Assembly drawing	
Template type: SW2020 Version: V1-1 SW_A2_hori_Sheet_format_V1-1	Pick&Place / DM01-23 & DM03-23	Drawing number / Index 0380-0003A	
	Art.No.: 0300-0003	Scale 1:2	Sheet 1 / 3

The copyright to this document, which is personally entrusted to the recipient, remains with our company. Without our written permission, the document may not be copied nor reproduced nor communicated or made accessible to third parties without our written permission.

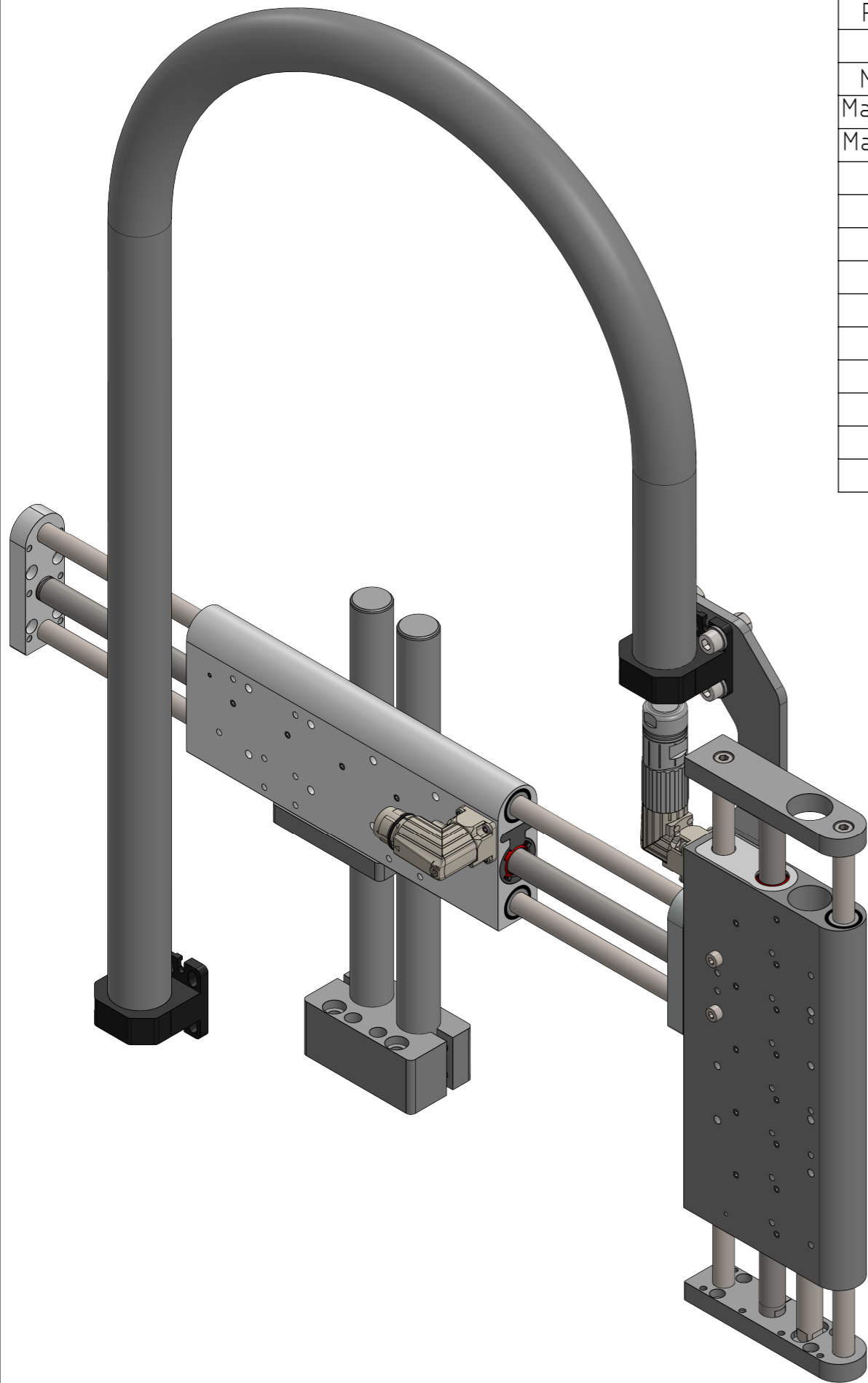

Stage type	PP_DM01-210-MT08_DM03-80-MT08-MS11_PS01_TC01	
Motor type	Horizontal: DM01-23x160H-XP-R-210	Vertical: DM03-23x160H-XP-R-80_CS10_MS11
Stroke	210	80
Max. Force@48VDC [N]	137	137
Max. Force@72VDC [N]	137	137
Position resolution [mm]	0.002	0.002
Repeatability [mm]	±0.05	±0.05
Max. acceleration [m/s <sup>2</sup> ]	< 50	< 50
Max. Velocity@48VDC [m/s]	4.9	4.9
Max. Velocity@72VDC [m/s]	7.3	7.3
Deviation	see datasheet	see datasheet
Moving part	Hardened steel, hard chrome-plated	Hardened steel, hard chrome-plated
Moving mass [kg]	0.940	0.940
Static part	Anodized aluminum	Anodized aluminum
Static mass [kg]	0.960	1.155
Max. payload	see datasheet	see datasheet
Stage mass [kg]	5.70	
Grease type	SKF LGFP 2	SKF LGFP 2
Drive architecture	Horizontal: Single	Vertical: Single
Recommended drive	C1200	C1200

Accessories		
Stage type	PP_DM01-210-MT08_DM03-80-MT08-MS11_PS01_TC01	
Motor type	Horizontal: DM01-23x160H-XP-R-210	Vertical: DM03-23x160H-XP-R-80_CS10_MS11
Safety	Not available	Not available
Clean room	Available: not chosen	Not available
External sensor	Not available	Not available
Cover	Not available	Not available
Cable guide	Chosen: TC01	Chosen: TC01
Pillar system	0150-6388 Z01-SB-20x2 0150-6386 Z01-SL-20x250 0150-6387 Z01-SA-20x2	Not available
Force sensor	Available: not chosen	To be released
Fan Kit	Not available	Not available

A	Document created	14.11.2024	JB	FH
Rev.	Change	Date	Author	Appr.

General tolerance DIN ISO 2768 - mK	Created by J.-E. Beekhuis	Status 13.12.2024 / jb	Material
<b>LinMot®</b>	0380-0003_PP_DM01-210-MT08_DM03-80-MT08-MS11_PS01_TC01		<input type="checkbox"/> Safety Rel. Weight (g) <input type="checkbox"/> UL-Rel.
NTI AG LinMot & MagSpring Bodenaeckerstrasse 2 CH-8957 Spreitenbach	Title, additional title PP_DM01-210-MT08_ DM03-80-MT08-MS11_PS01_TC01		Document type Assembly drawing
Template type: SW2020 Version: V1-1 SW_A3_hori_Sheet_format_V1-1	Pick&Place / DM01-23 & DM03-23 Art.No.: 0300-0003		Drawing number / Index 0380-0003A
	Scale 2:5		Sheet 2 / 3 A3

2m cable conduit  
45mm minimum bending radius, static

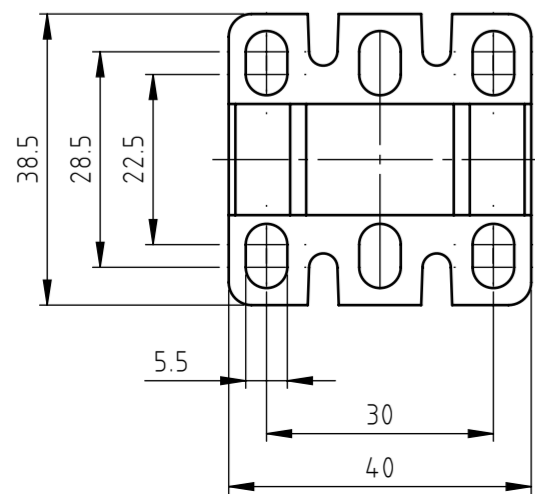
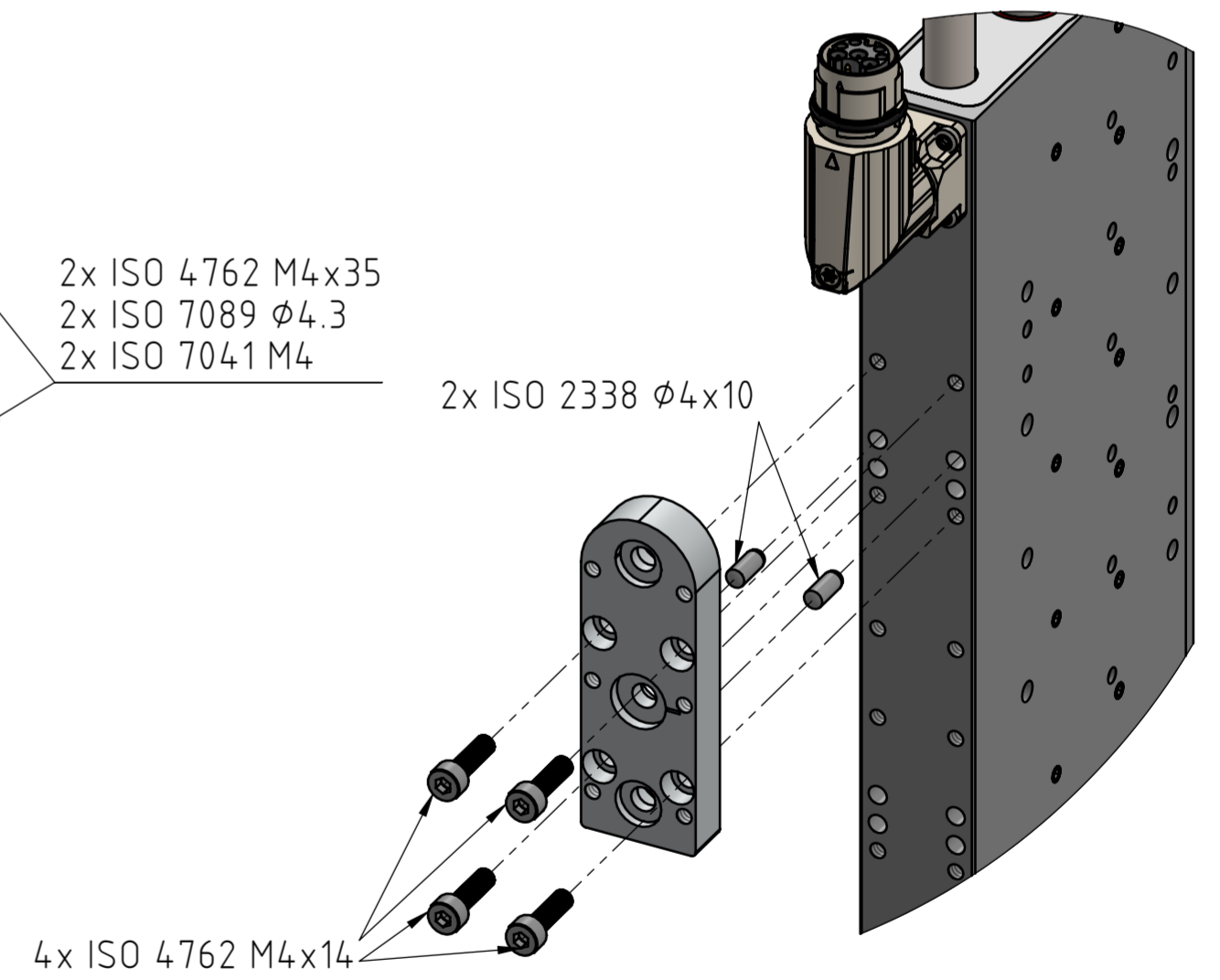
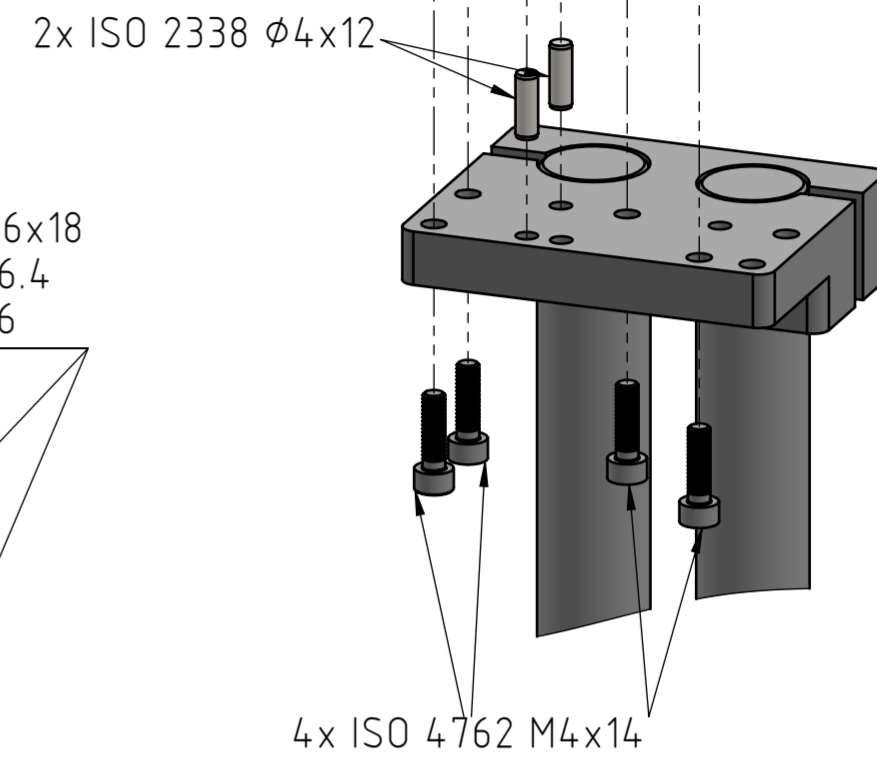
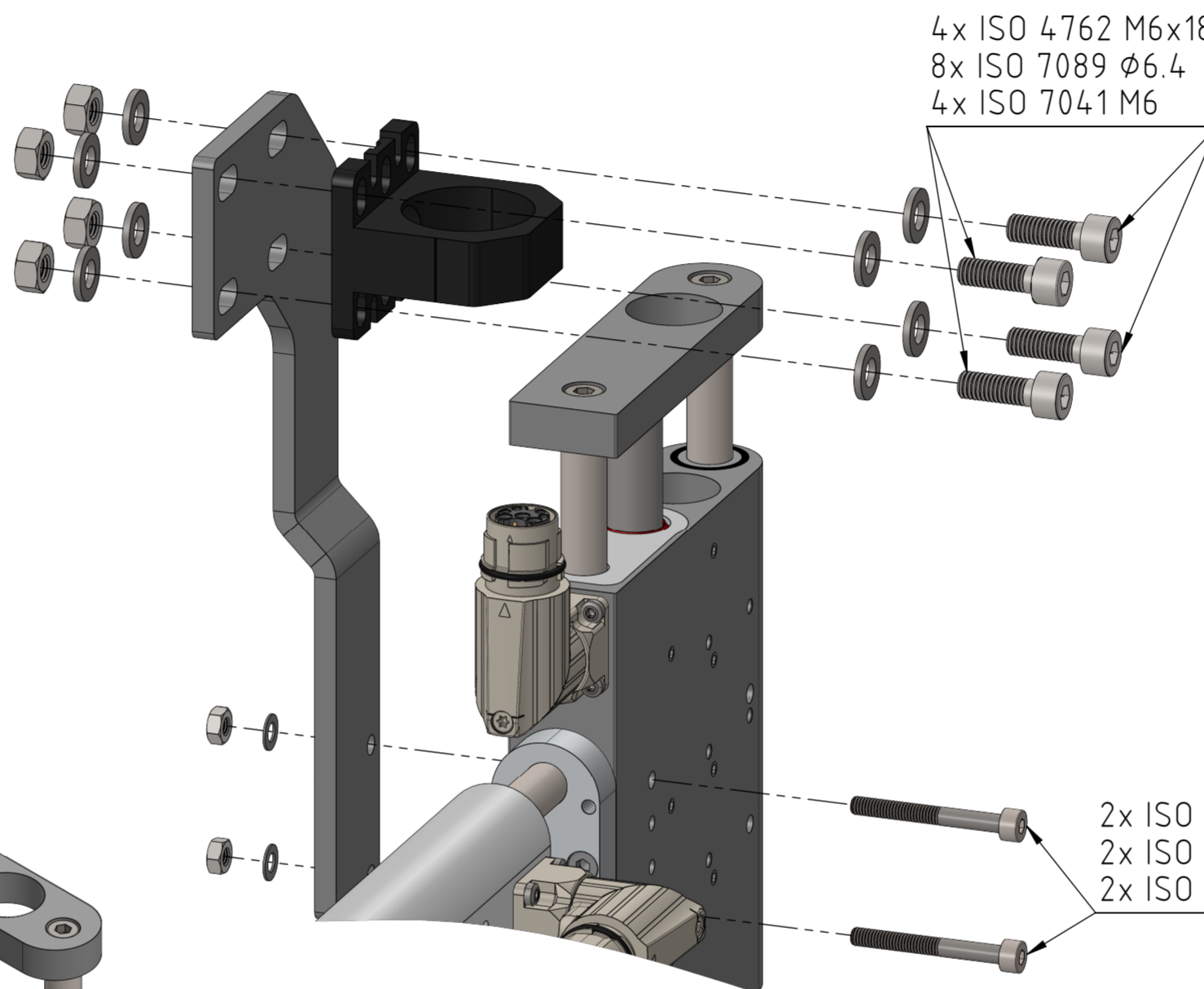
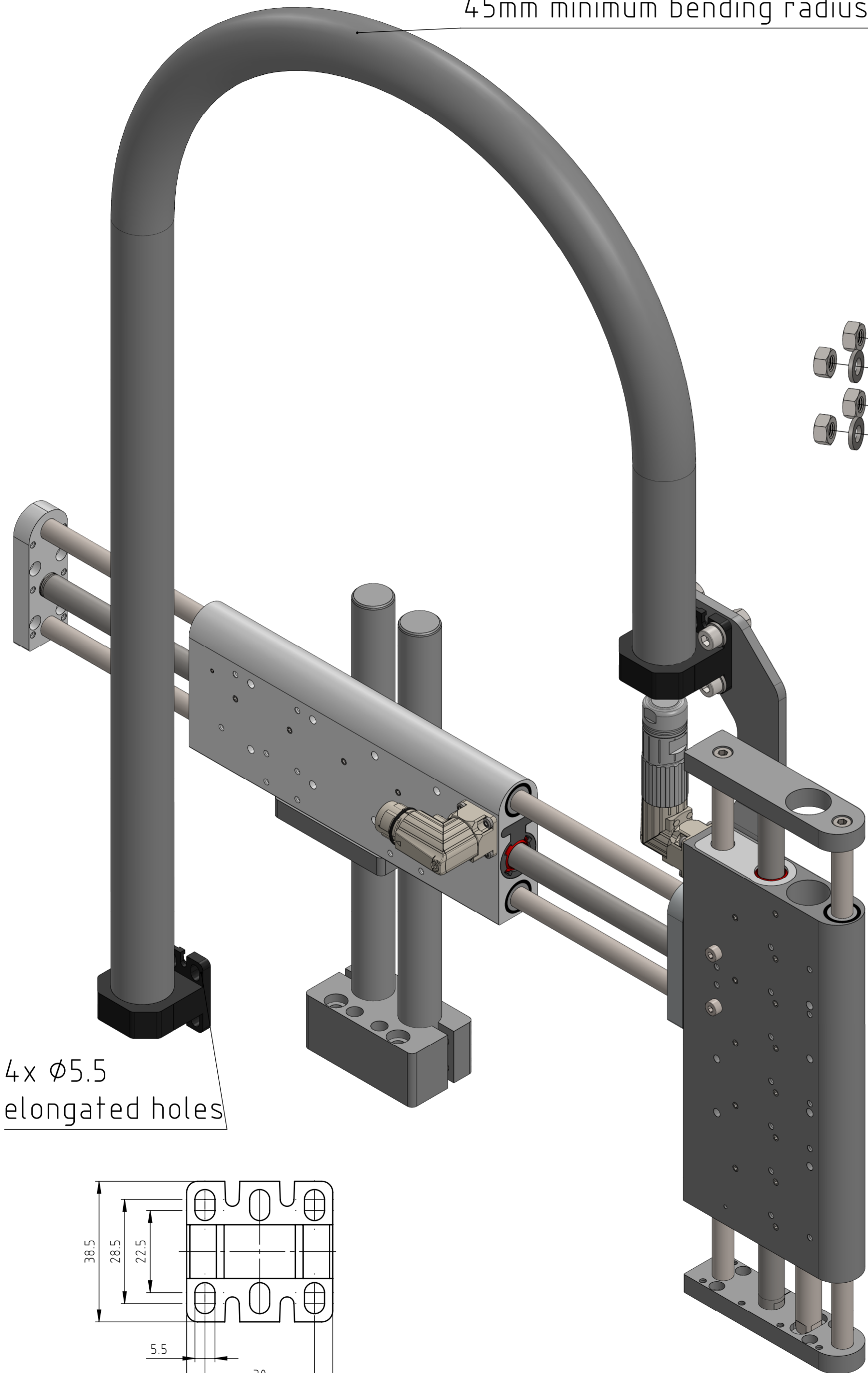

Rev.	Change	Date	Author	Appr.
A	Document created	14.11.2024	JB	FH

General tolerance DIN ISO 2768 - mK	Created by J.-E. Beekhuis	Status 13.12.2024 / jb	Material
<b>LinMot®</b>	File name 0380-0003_PP_DM01-210-MT08_DM03-80-MT08-MS11_PS01_TC01	<input type="checkbox"/> Safety Rel. Weight (g) <input type="checkbox"/> UL-Rel.	
NTI AG LinMot & MagSpring Bodenaeckerstrasse 2 CH-8957 Spreitenbach	Title, additional title PP_DM01-210-MT08_ DM03-80-MT08-MS11_PS01_TC01 Pick&Place / DM01-23 & DM03-23	Document type Assembly drawing Drawing number / Index 0380-0003A	
Template type: SW2020 Version: V1-1 SW_A2_hori_Sheet_format_V1-1	Art.No.: 0300-0003	Scale 3:5	Sheet 3 / 3 A2

The copyright in this document, which is personally entrusted to the recipient, remains with our company. Without our written permission, the document may not be copied nor reproduced nor communicated or made accessible to third parties without our written permission.